

J. B. LOGAN.
Gang Plow.

2 Sheets—Sheet 1.

No. 84,634.

Patented Dec. 1, 1868.

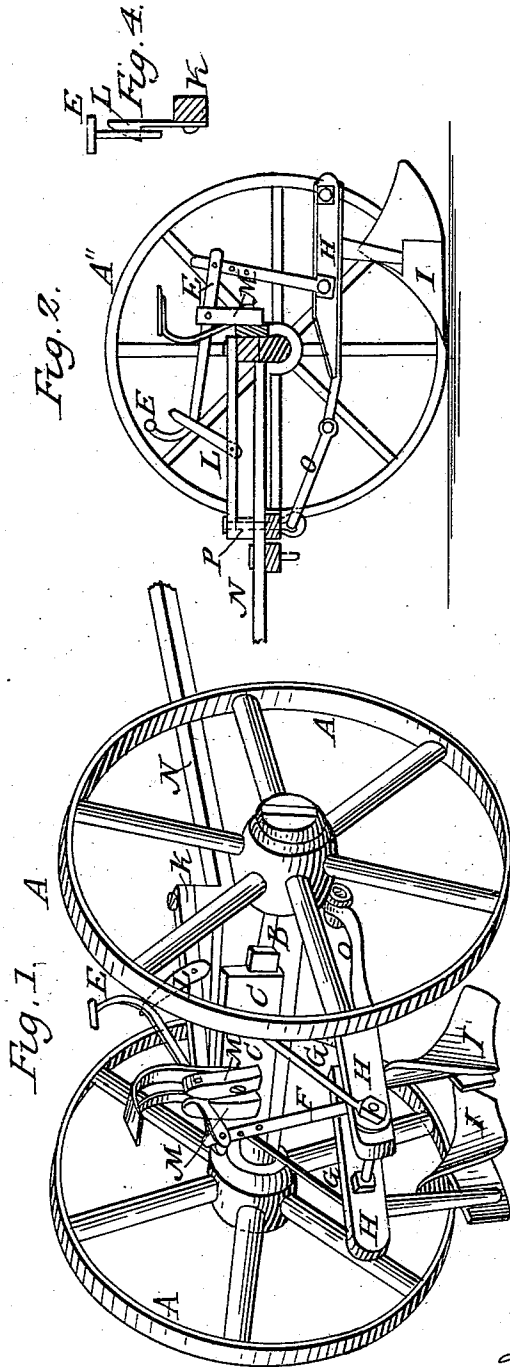

Witnesses:
F. H. Prager
E. T. Blain

Inventor:
J. B. Logan
By *R. P. Holloway & Co*
Atty.

J. B. LOGAN.

2 Sheets—Sheet 2.

Gang Plow.

No. 84.634.

Patented Dec. 1, 1868.

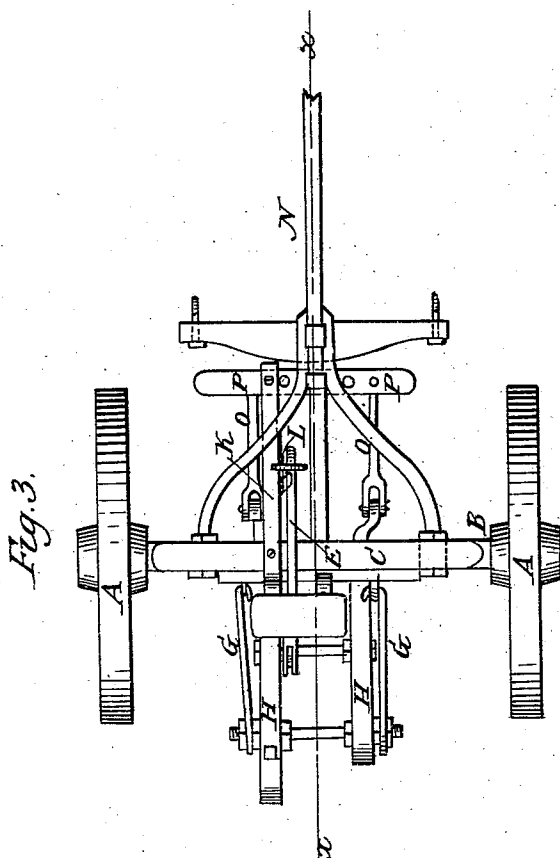

Witnesses:
E. H. Prognus
E. T. Claudin

Inventor:
J. B. Logan
By D. P. Holloway & Co
Atty.

United States Patent Office.

JAMES B. LOGAN, OF RICHVIEW, ILLINOIS.

Letter's Patent No. 84,634, dated December 1, 1868

IMPROVEMENT IN GANG-PLOWS.

The Schedule referred to in these Letters Patent and making part of the same.

To all whom it may concern :

Be it known that I, JAMES B. LOGAN, of Richview, in the county of Washington, and State of Illinois, have invented a new and useful Improvement in Gang-Plows; and I do hereby declare that the following is a full, clear, and exact description of the same, reference being had to the annexed drawings, making part of this specification, in which—

Figure 1 is a perspective view of the entire machine;

Figure 2 is a central sectional elevation, on the line $x-x$ of fig. 3; and

Figure 3 is a top view of the machine.

Figure 4 is an elevation of the hook that holds the lever in position, which is used for raising and lowering the plows.

Similar letters denote corresponding parts in the several figures.

A are the wheels;

B is the axle; and

C is the bolster, placed upon the top of the axle, in the usual manner.

All of the above parts are of ordinary construction, and need not be further described in this connection. I would remark, however, that I contemplate using the front wheels, axle, and gear of a common farm-wagon, and attaching thereto my improvements, or, as is evident, these parts may be constructed, with reference to their use, in such connection. In either case, they will be substantially like those in common use, and hence their description will be omitted, except in so far as it becomes necessary to show their connection with my improvements.

In attaching to the running gear of a wagon my improvements, I bolt to the tongue thereof, at a point just in the rear of the double-tree, and where the hounds or braces, which unite the tongue with the axle, diverge, a cross-beam, P, of, say, two and one-half by three and one half-inches, and of sufficient length to receive the rods, O, to which the beams of the plows are connected.

Near the outer ends of the beam P, staples are secured, through which a portion of the brace O, which has been turned at a right angle with its main portion, is passed, which leaves the opposite end of said beam free to rise and fall with the plows, as they enter or leave the earth.

To the rear end of the braces O, the forward ends of the plow-beams are jointed, in such a manner as to swing freely thereon, and admit of the plows and their beams being raised and lowered without causing the beams to be raised from a horizontal line, which is a very important feature, and which constitutes one of the novelties of my invention.

The jointed portions of the beam H, above described, are of metal, which extends back for a sufficient distance to receive the tapering end of the beam, it being formed with two diverging parts for that purpose.

To the wooden portion of the beams, the plows I are attached, in the usual or any proper manner.

Through the rear portions of the beams H, a hole is bored at right angles to their line of motion, through which a bolt or rod is passed, which has a thread cut

upon it, so that, by means of threaded nuts, working upon such screws, the relative position of the plows can be adjusted and secured.

To the outer ends of these rods, braces, G, are attached by eyes, formed in their lower ends, which extend upward and forward, at the proper angle to pass into staples, which are secured to a suitable piece of timber, which is bolted to the bolster of the axle for that purpose.

About midway of the wooden portion of the beam, or at such point thereon as will cause the plows to balance the forward ends, another rod or bolt is passed through said beams, and secured by nuts, to which is hinged the hanger F, which extends upwards for a distance sufficient to enable it to be connected to the lever E, which is used to lower and raise the plows.

To the timber, above described as being secured to the bolster C, are bolted two uprights, M M, to the upper ends of which the lever E is pivoted, which pivot forms the fulcrum of said lever.

The lever E, above referred to, is connected to the hanger F at its rear end, and pivoted to the uprights, forward of which it extends for a sufficient distance to enable the operator to raise and lower the plows with facility, and is secured against lateral movement by a slotted piece of metal, which is placed astride it, and bolted to the bolster.

Extending from the bolster forward to the cross-beam P, and secured to each, is a timber or support, to which the catch or dog L is pivoted, and which is provided, upon its upper end, with a hook, which passes over the lever E, and retains it in position when the plows have been raised to any desired height.

It will be observed that the forward ends of the braces or hangers O O, to which the beams are attached, and by which the plows are propelled, are attached to the cross-beam P, in such a manner as to permit them to swing freely in their joints, and that, as a consequence of this arrangement, I am enabled to raise and lower the plows in a vertical line, instead of their moving in an arc of a circle, as is usual.

By the described arrangement, I am enabled to force the plows into the earth to any required depth, without increasing their tendency either to leave the earth or to penetrate it to a greater depth.

Having thus described my invention,

What I claim, and desire to secure by Letters Patent, is—

The combination and arrangement of the beams H, swinging beams O and G, the hangers F, and lever E, the arrangement being such that the plows are drawn by the levers O, which are attached to the forward ends of the levers thereof, substantially as shown and described.

In testimony whereof, I have signed my name to this specification, in the presence of two subscribing witnesses.

JAMES B. LOGAN.

Witnesses:

JAMES BASSETT,
JOHN PATE: