

(No Model.)

H. J. DURGIN.
FOLDING EXTENSION TABLE.

No. 577,014.

Patented Feb. 16, 1897.

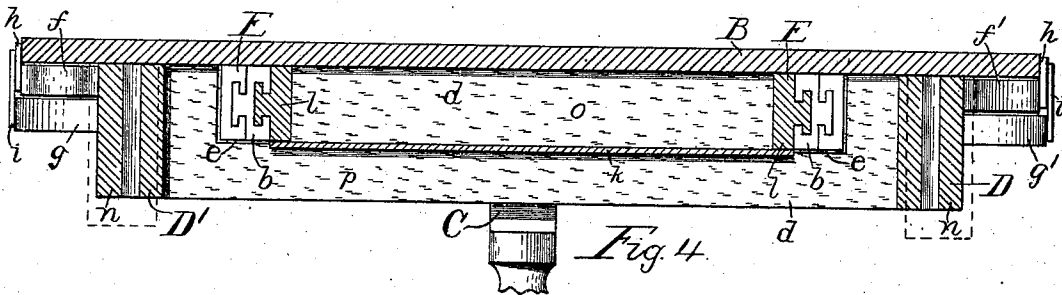
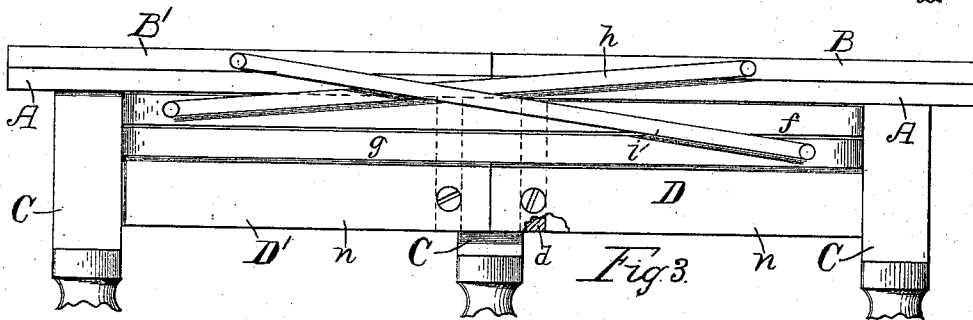
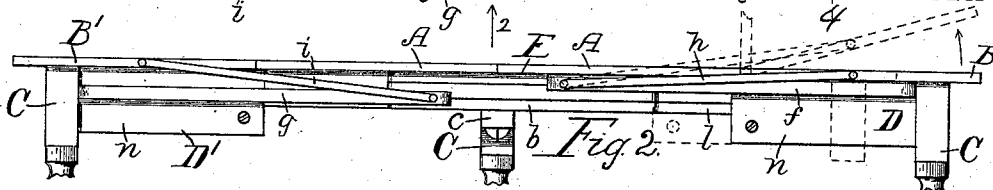
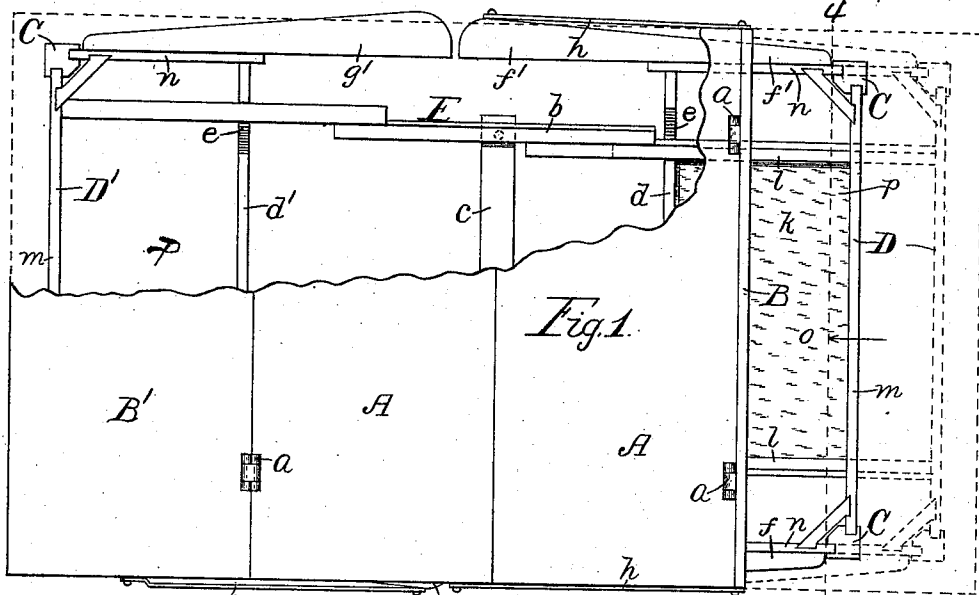

Attest:
M. L. Winston.
A. H. Hilborn

Inventor:
H. J. Durgin,
by C. S. Whitmore,
Att'y.

UNITED STATES PATENT OFFICE.

HENRY J. DURGIN, OF ROCHESTER, NEW YORK.

FOLDING EXTENSION-TABLE.

SPECIFICATION forming part of Letters Patent No. 577,014, dated February 16, 1897.

Application filed July 20, 1896. Serial No. 599,886. (No model.)

To all whom it may concern:

Be it known that I, HENRY J. DURGIN, of Rochester, in the county of Monroe and State of New York, have invented a new and useful Improvement in Folding Extension-Tables, which improvement is fully set forth in the following specification and shown in the accompanying drawings.

My invention relates to extension-tables, and more particularly to dining-room tables, and it is one in which the leaves are foldable over on top of the rigid part of the bed or top of the table. The device is such that it constitutes a complete symmetrical table whether the leaves are folded to make the table short or whether they are turned outward to make the table long. This table, which I call a "folding extension-table," is thus susceptible of being formed into approximately a square table or an elongated dining-room table about twice as long as wide.

The invention is hereinafter fully described and more particularly pointed out.

Referring to the drawings, Figure 1 is a plan of the table with one leaf turned vertically upward, parts being broken away and other parts shown in two positions by full and dotted lines. Fig. 2 is a side view seen as indicated by arrow 2 in Fig. 1, parts being shown in two positions by full and dotted lines. Fig. 3 is a similar side view of the table, the leaves being folded. Fig. 4 is a vertical section on the dotted line 4 4 in Fig. 1, viewed as indicated by arrow pointed on the line. Figs. 3 and 4 are drawn to scales about twice that of Figs. 1 and 2.

Referring to the figures, A is the fixed or rigid central part or section of the top of the table, B B' being the leaves. The leaves are joined to the rigid part A by suitable hinges *a*, some good form of flush hinge being preferably employed. C are the legs of the table, which may be of any number above three, five being shown, one at each corner and one at the center.

The frame of the table, which is in some respects of the usual form, is divided into two independent parts D D' under the leaves B B', respectively. Two sets of slides E E are employed in the construction of the table, which are of substantially the usual form. The middle part *b* of each set of slides is se-

cured rigidly to the part A of the table by common means. Beneath the parts *b b*, and midway of their lengths, is secured a stout cross-bar *c*, to which the central leg C is made fast.

The parts or sections D D' of the frame are independent of each other, but connected, each being formed with an end rail *m* and side rail *n n*, and further provided with inner members *d d'*, extending from side to side, giving to each part of the frame the form of a rectangular inclosure *p*, as shown in Fig. 1. These parts D D' of the frame are adapted to move toward or from each other by means of the slides E E.

The members *d d'* of the frame are the same in vertical dimensions as the side rails of the frame, reaching from the under surface of the top of the table downward with their lower edges in the plane of the lower surface of the frame. These members are notched at *e e* to make way for the slides, as shown.

The side rails of the frame are formed with overhanging or extended parts *f f'* and *g g'*, relatively so placed that when the table is folded or closed the two parts *f f'* at one end of the table will pass over the two parts *g g'* at the other end of the table, as shown in Figs. 3 and 4. The inner edges of these extended parts are substantially straight and in line with the contiguous vertical faces of the side rails of the frame, but their outer edges are inclined and preferably rounded at their ends, as shown in Fig. 1. These extended parts are made broader at their inner adjacent ends than at the opposite ends and serve as holders for links *h h* and *i i*, one end of each of said links being pivoted to the respective broad ends of said extended parts, as shown, so as to move in vertical planes. The opposite ends of the respective links are similarly pivoted to the ends of the leaves B B'.

It will be now understood that when either leaf is turned upon its hinges it will act as a lever of the second order and cause the part of the frame beneath it to move also toward or from the center of the table. When the table is opened out or extended, as appears in full lines in Fig. 2, the link-holders and links will occupy substantially the relative positions therein shown; but when the leaves

are folded over on top of the table the link-holders will be brought one pair over the other, with their ends in vertical planes and the links crossing each other, as shown in Fig. 3.

The table is preferably mounted upon casters in the usual manner, so that when the leaves are turned the sections of the frame will roll easily along the floor.

To further specify, when a leaf is turned one way or the other it carries with it the part of the frame and the two legs beneath it on account of the action of the links or connectors, the sections of the slides moving upon each other correspondingly. When the table is closed or folded, the ends of the side rails *n* meet and abut together, as shown in Fig. 3, the table being substantially square on the top and the edges of the leaves meeting in a close joint at the middle of the table, as shown. The table is then in condition for use, the top part being of double thickness, and the corner legs are fairly and regularly under the double top, as though the table were originally constructed in that form; also when the leaves are turned outward, giving to the table its extended form, as shown in Fig. 2, the corner legs are correspondingly carried outward, so as to stand regularly under the corners, as before.

I usually form a drawer or apartment *o* at the right-hand end of the table, as appears in Fig. 1, by securing a bottom board *k*, Figs. 1 and 4, to the under surfaces of the parts *ll* of the slides. The latter form the two sides of the drawer; the front and rear sides being formed, respectively, by the end rail *m* and the member *d*. When the leaf is raised, the drawer is uncovered and its interior exposed to view, as appears in Fig. 1.

What I claim as my invention is—

1. A table comprising a frame composed of two similar independent parts connected and adapted to move toward or from each other, and slides for the parts, in combination with a rigid central section of the bed or top secured to the slides, and folding leaves joined to two opposite sides of said rigid central section, said leaves being adapted to be turned to form horizontal extensions of said central section or to turn over horizontally upon the top of said section with their free edges forming a close joint, and means for connecting the leaves and the independent parts so that as the leaves are swung upon their hinges the parts will be moved toward or from the central part, substantially as shown and described.

2. A table having a divided frame and a top or bed, and folding leaves joined to the bed, and connectors for said leaves and the frame whereby when the leaves are turned they act to move the said parts of the frame, substantially as specified.

3. A table having a divided frame and a top or bed, and folding leaves joined to the bed, and links or connectors for said leaves and the respective parts of the frame whereby when a leaf is turned to the right or to the left its accompanying part of the frame will move in a corresponding direction and so always be under the leaf, substantially as shown and set forth.

4. A table having a rigid central portion, leaves hinged to the opposite sides thereof, a movable frame at each end of the table, and overhanging parts secured to each side of each frame, and a link or connector secured to the overhanging portion and to its respective leaf, substantially as set forth.

5. A table having a rigid central portion, leaves hinged to opposite sides thereof, a movable frame at each end of the table, an overhanging portion secured to each side of each frame, one end of which is wider than the other and passes over the opposite frame when the table is closed, and a link secured to the wider end of each of the overhanging portions and to the end of its respective leaf, substantially as set forth.

6. A table having a rigid central portion, a movable frame under each end of the table, means for connecting each of the frames with the central portion, a drawer formed in one of the frames, leaves hinged to the opposite sides of the central portion, and means for connecting each leaf with the frame upon that side, whereby the leaf and the frame may be moved in unison, substantially as set forth.

7. A table having a rigid portion, a movable frame under each end of the central portion, the inner piece of each frame being recessed, slides for connecting each of the frames of the central portion, said slides fitting within the recesses of the frames, leaves hinged to the opposite side of the central portion, and means for connecting the frames and the leaves, substantially as set forth.

In witness whereof I have hereunto set my hand, this 14th day of July, 1896, in the presence of two subscribing witnesses.

HENRY J. DURGIN.

Witnesses:

ENOS B. WHITMORE,
M. L. WINSTON.