



US006317984B1

(12) **United States Patent**
Okabe

(10) **Patent No.:** **US 6,317,984 B1**
(45) **Date of Patent:** ***Nov. 20, 2001**

(54) **INNER CUTTER FOR A RECIPROCATING ELECTRIC SHAVER AND RECIPROCATING ELECTRIC SHAVER**

(75) **Inventor:** **Masaki Okabe, Matsumoto (JP)**

(73) **Assignee:** **Izumi Products Company, Nagano (JP)**

(*) **Notice:** This patent issued on a continued prosecution application filed under 37 CFR 1.53(d), and is subject to the twenty year patent term provisions of 35 U.S.C. 154(a)(2).

Subject to any disclaimer, the term of this patent is extended or adjusted under 35 U.S.C. 154(b) by 0 days.

(21) **Appl. No.:** **09/392,107**

(22) **Filed:** **Sep. 8, 1999**

(51) **Int. Cl.⁷** **B26B 19/04**

(52) **U.S. Cl.** **30/43.92; 30/346.51**

(58) **Field of Search** **30/43.92, 346.51, 30/43.9, 43.91**

(56) **References Cited**

U.S. PATENT DOCUMENTS

4,030,573 * 6/1977 Buzzi et al. 30/43.92 X
5,611,145 * 3/1997 Wetzel et al. 30/43.92

FOREIGN PATENT DOCUMENTS

2035346 * 1/1971 (DE) 30/345.51

* cited by examiner

Primary Examiner—Douglas D. Watts

(74) *Attorney, Agent, or Firm*—Koda & Androlia

(57) **ABSTRACT**

An inner cutter being used for a reciprocating electric shaver and comprised of a pair of supporting wall sections that are disposed opposite to each other and small cutters that have an inverted U cross-sectional shape and are disposed between the upper ends of the pair of supporting wall sections in a plurality of numbers so as to be arranged along the direction of length of the supporting wall sections; and in this inner cutter, only the small cutters are disposed between the pair of supporting wall sections.

9 Claims, 10 Drawing Sheets

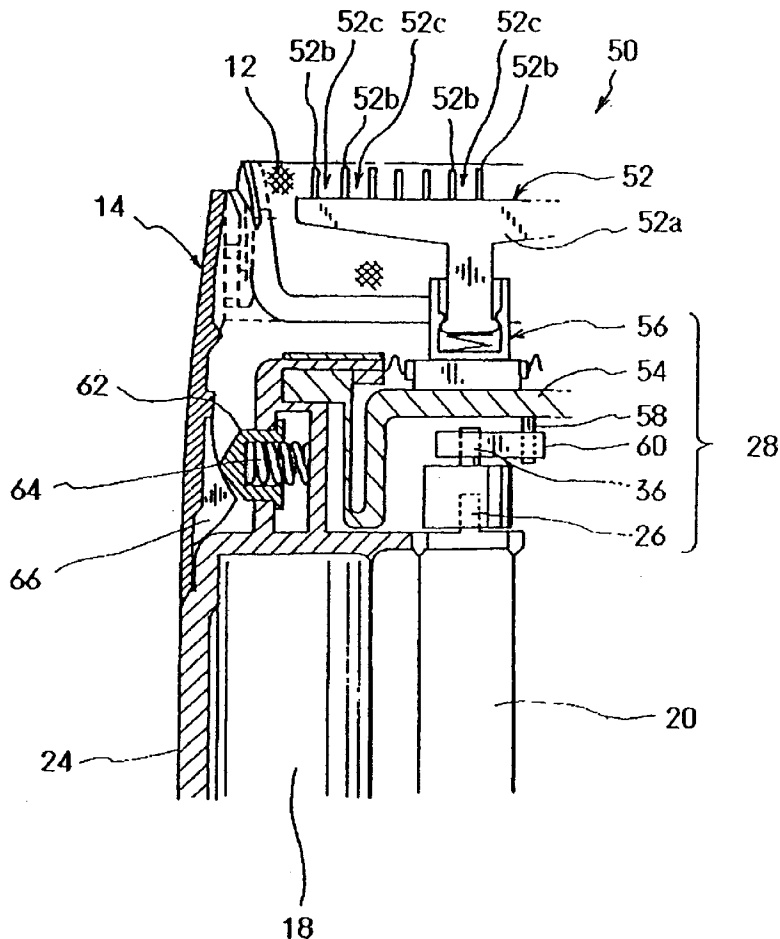

FIG. 1

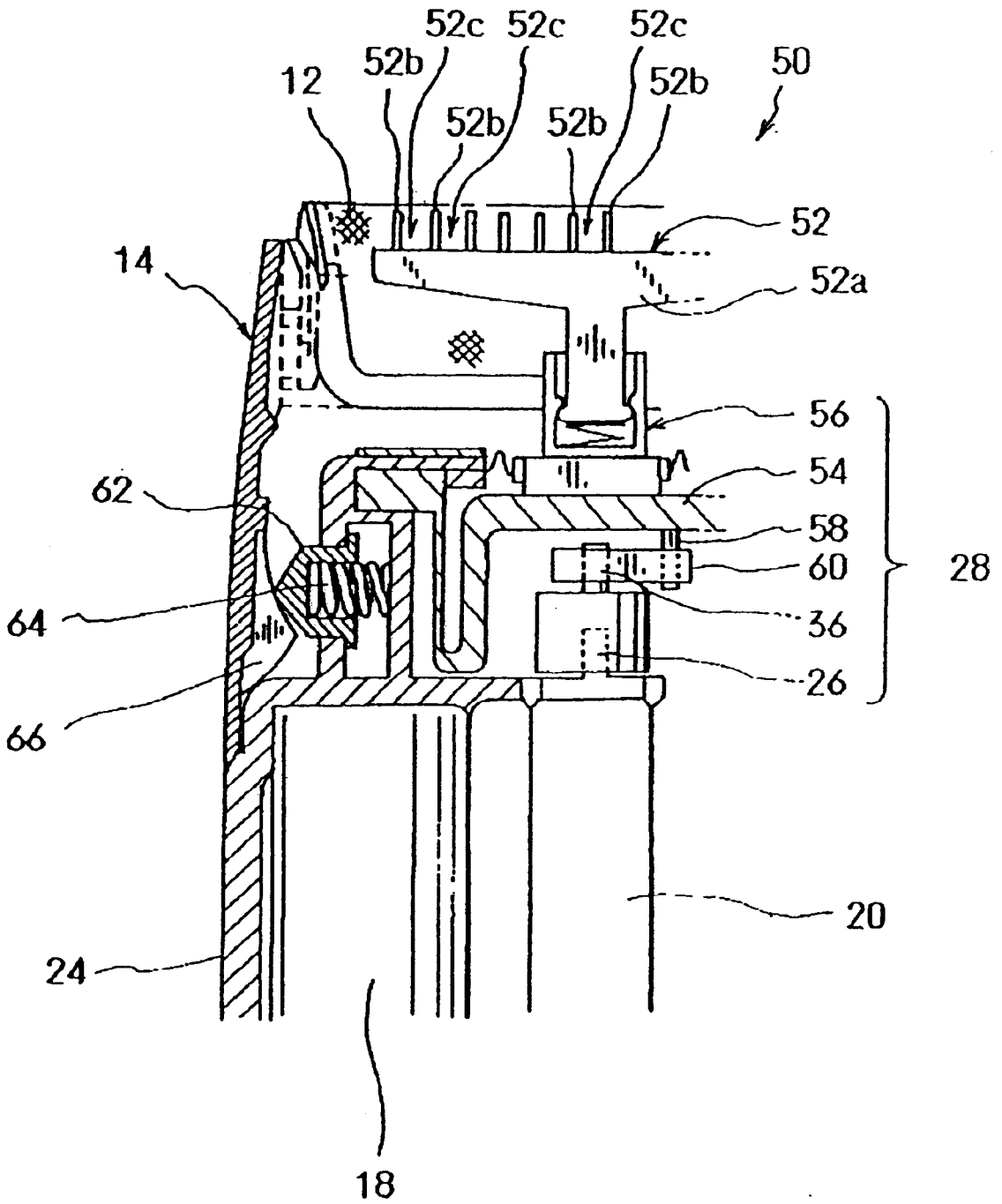

FIG. 2

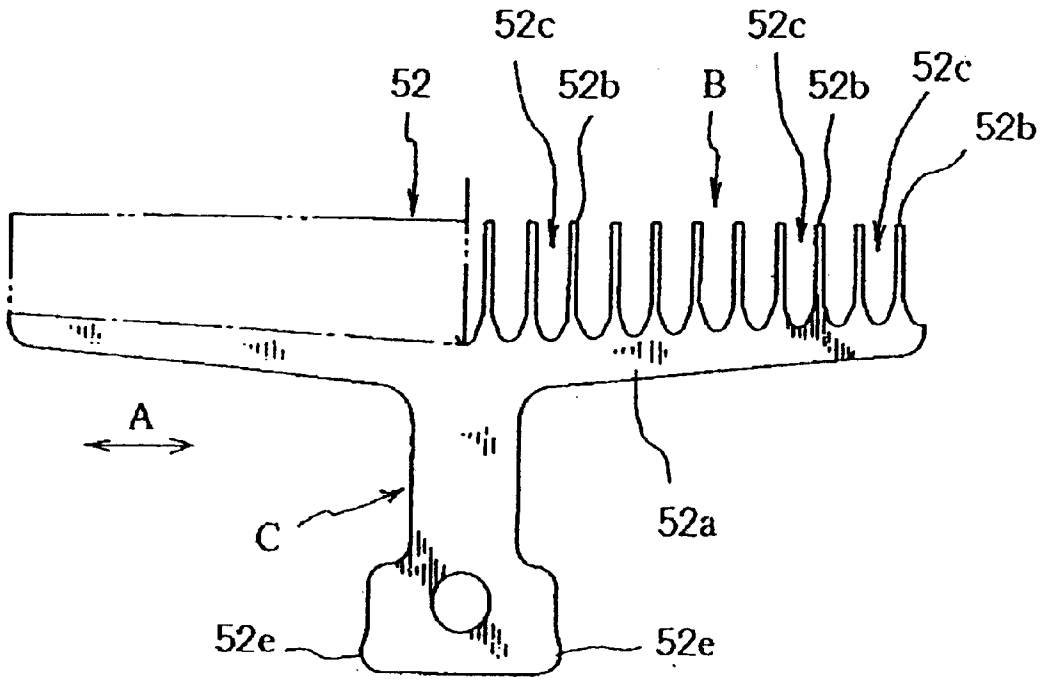

FIG. 3

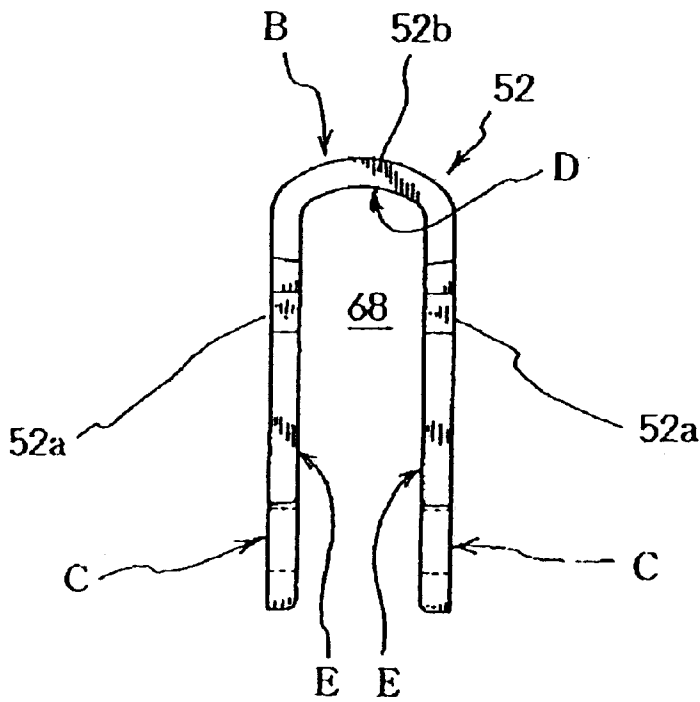

FIG. 4

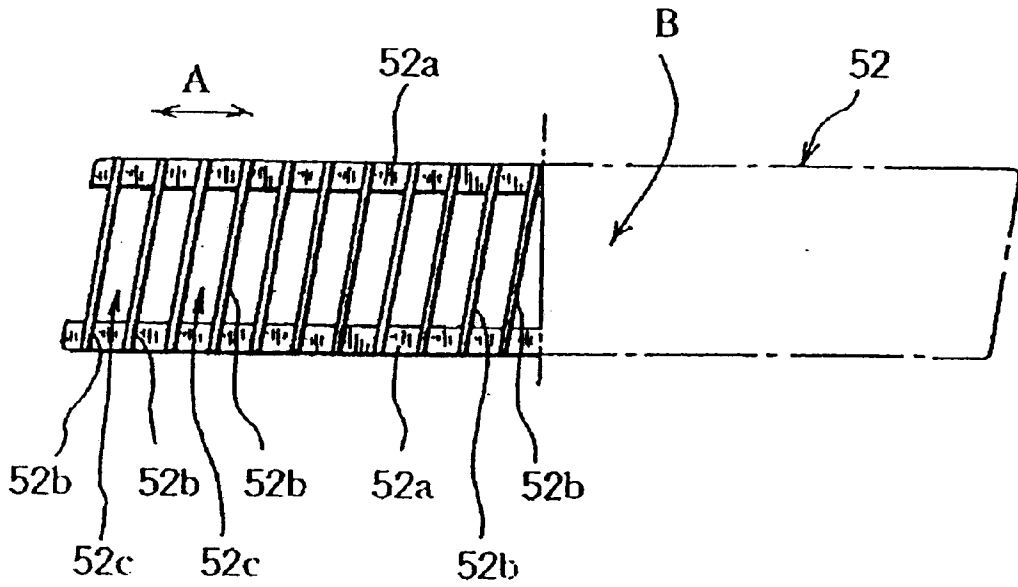

FIG. 5

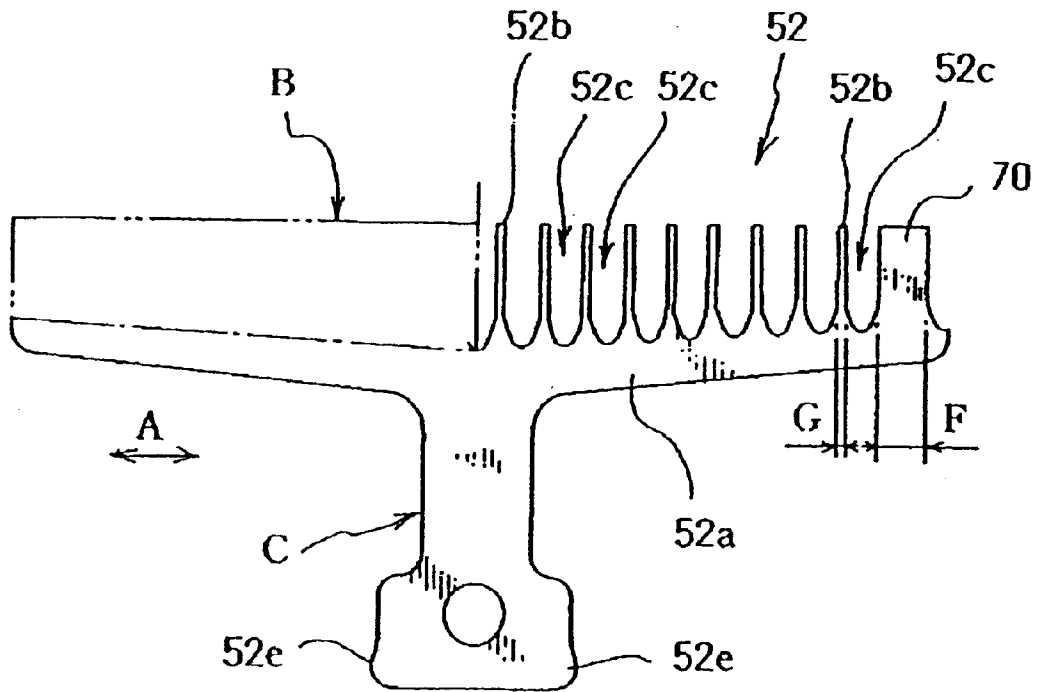

FIG. 6

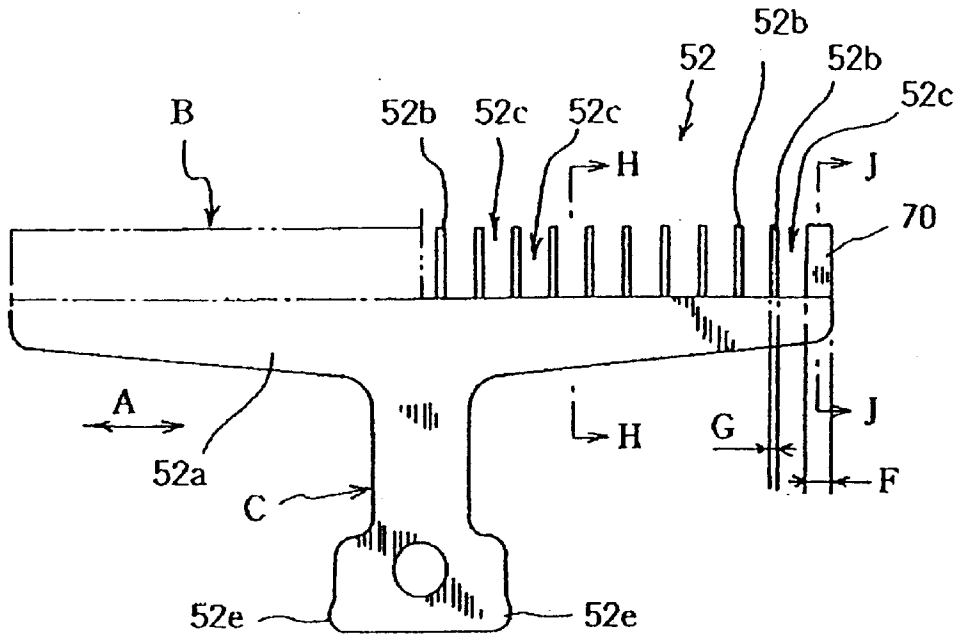

FIG. 7

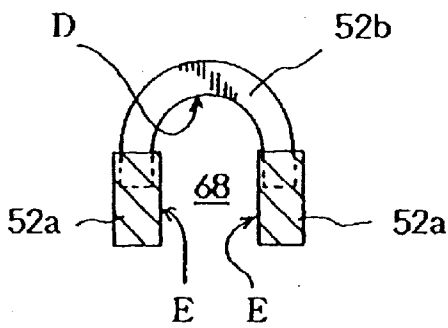

FIG. 8

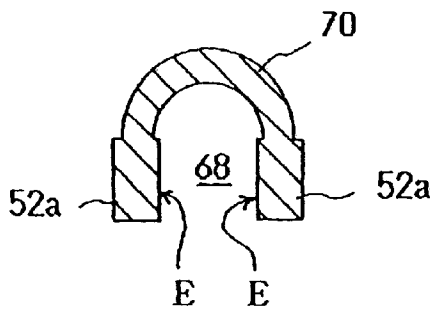

FIG. 9

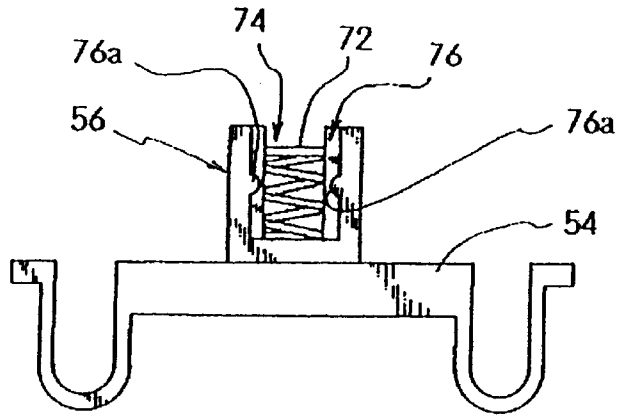

FIG. 10

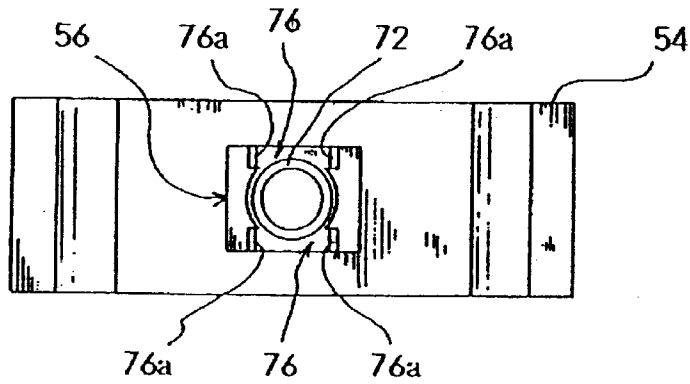

FIG. 11

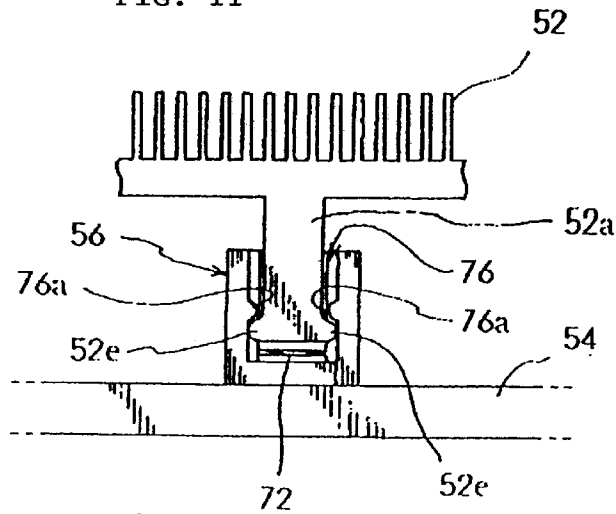

FIG. 12

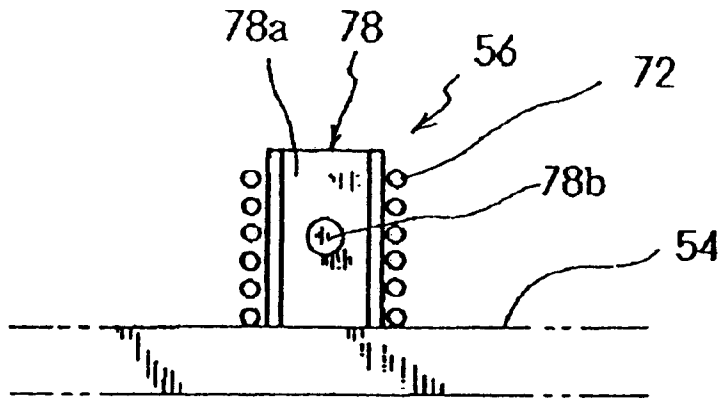

FIG. 13

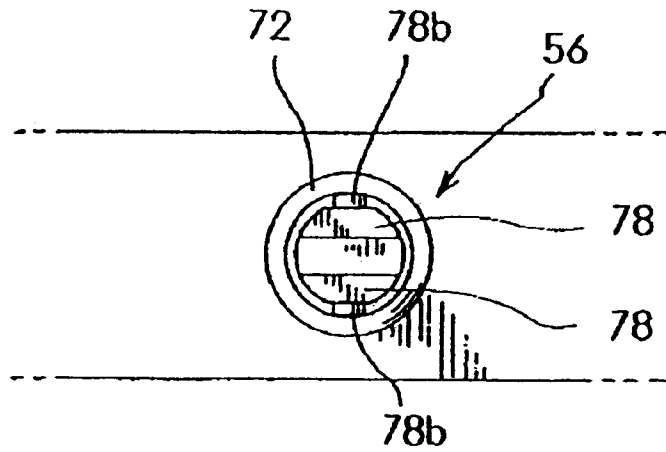

FIG. 14

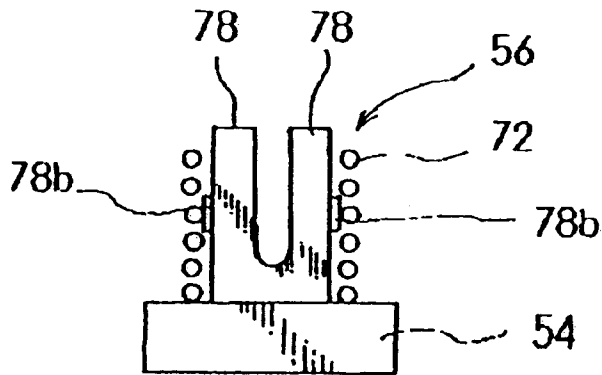

FIG. 15

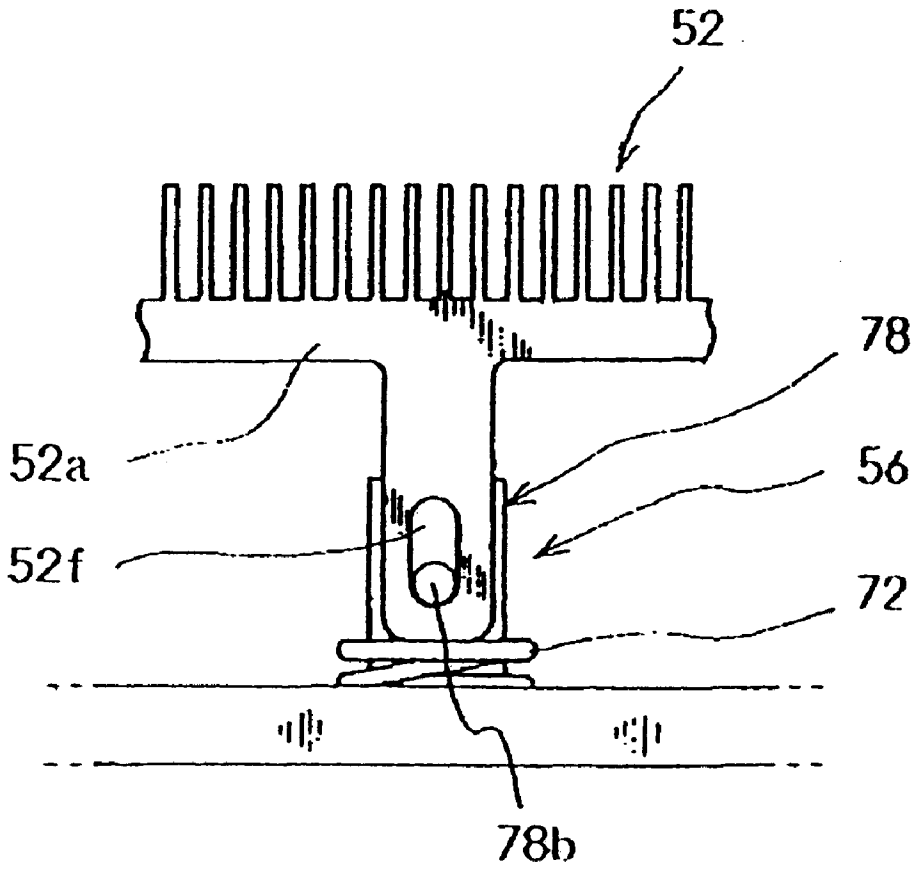

FIG. 16

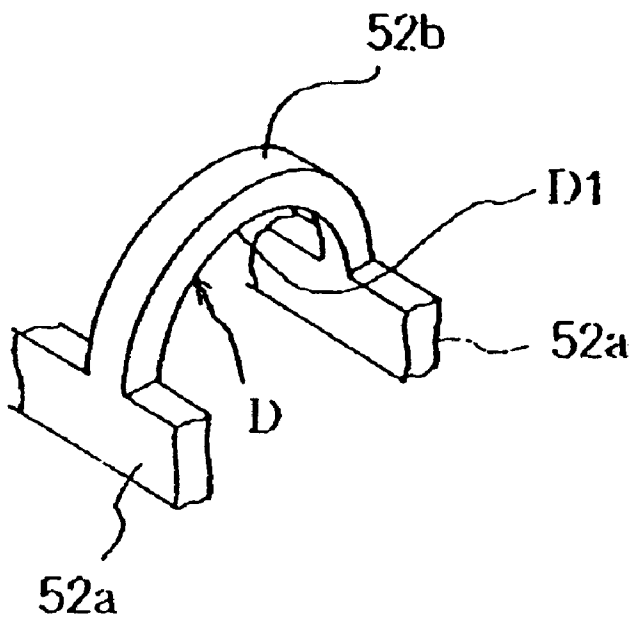

FIG. 17

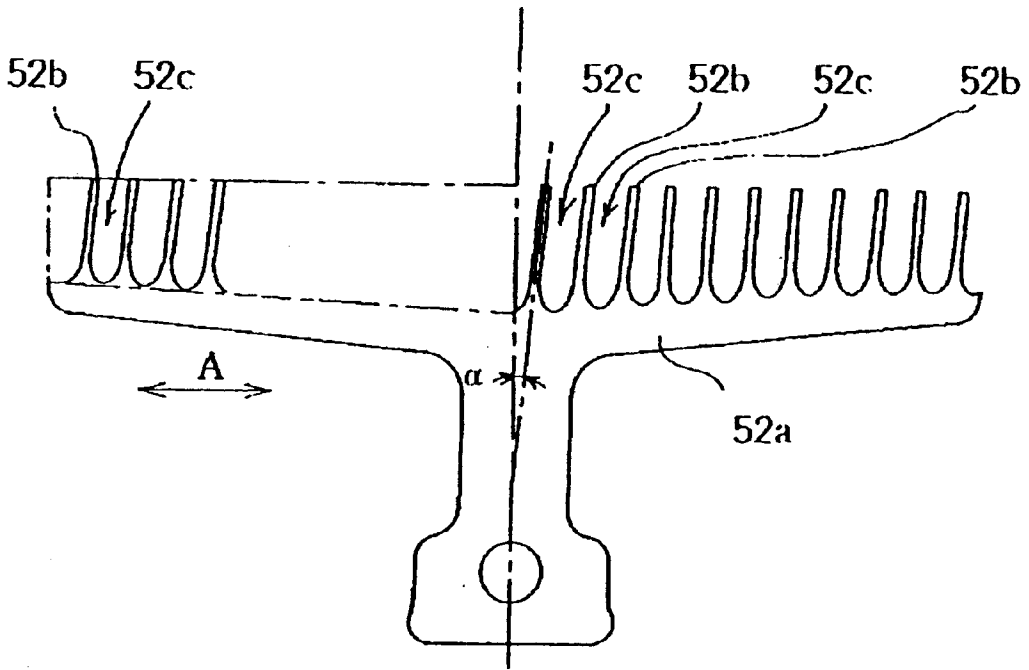

FIG. 18

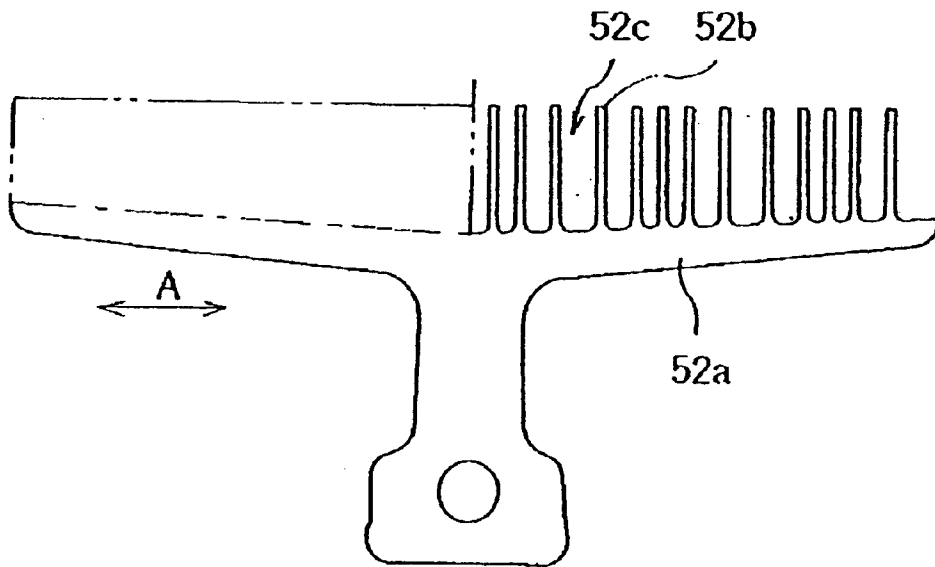

FIG. 19

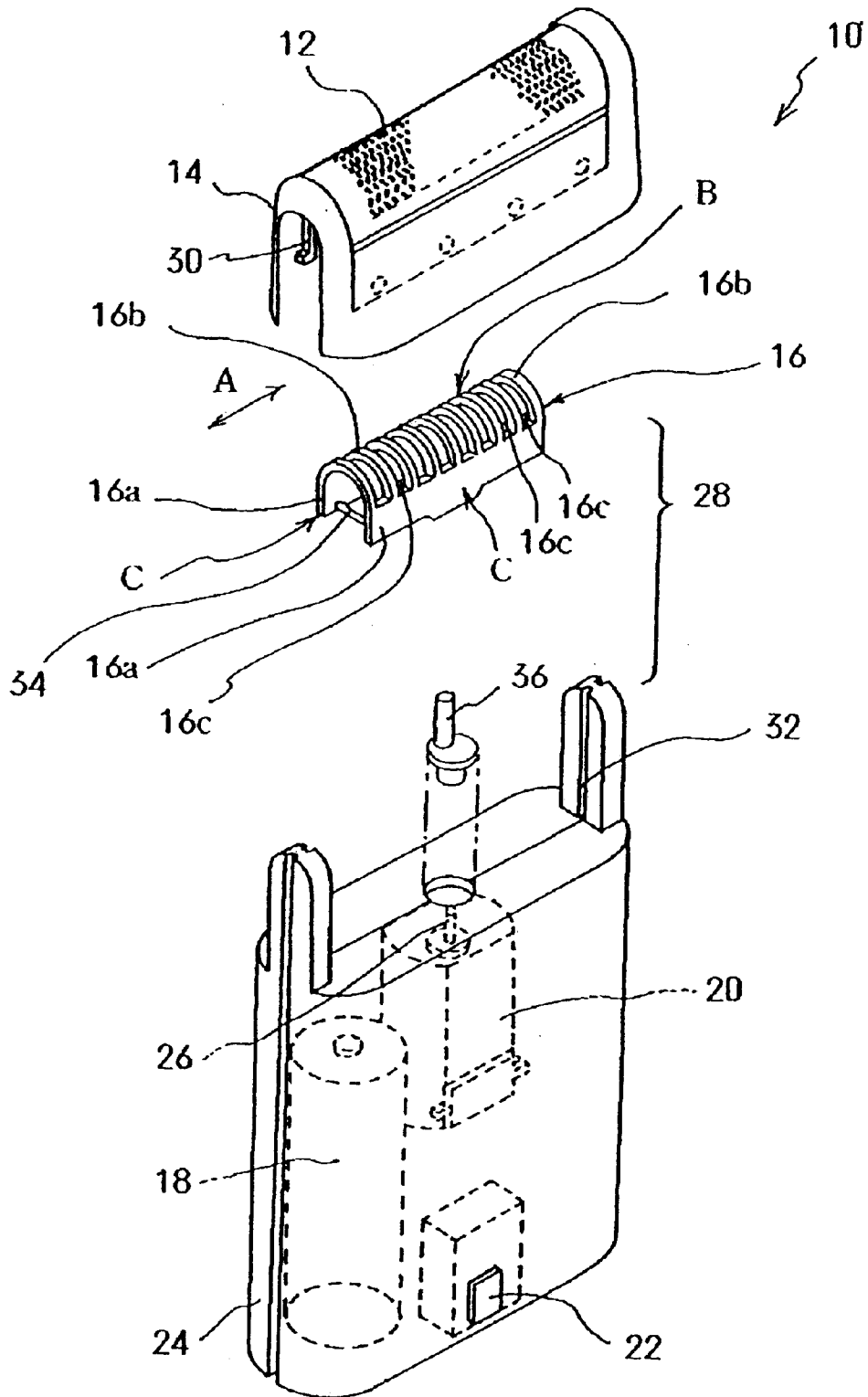
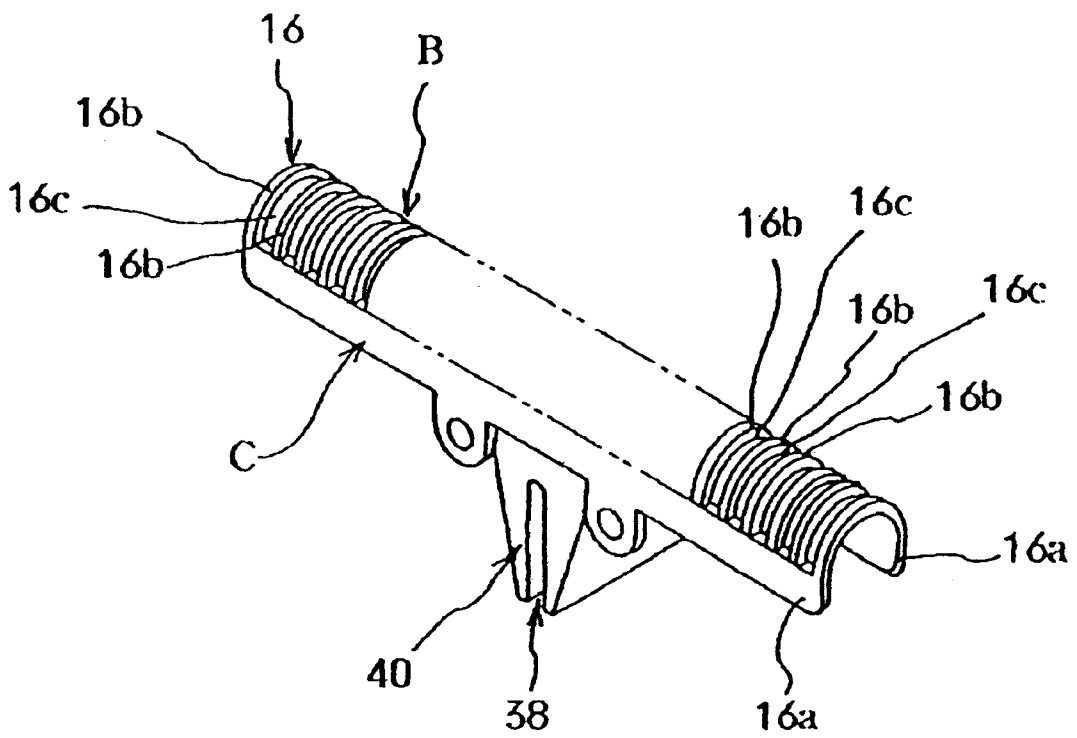

FIG. 20



INNER CUTTER FOR A RECIPROCATING ELECTRIC SHAVER AND RECIPROCATING ELECTRIC SHAVER

BACKGROUND OF THE INVENTION

1. Field of the Invention

The present invention relates to an inner cutter for a reciprocating electric shaver and a reciprocating electric shaver that uses such an inner cutter.

2. Prior Art

A conventional inner cutter for a reciprocating electric shaver will be described first.

The overall structure of an ordinary reciprocating electric shaver will be described with reference to FIG. 19.

The electric shaver 10 is comprised of: a mesh-form outer cutter 12 which is formed using a thin metal plate and has openings in the form of eyes of mesh, a holding frame 14 which holds this outer cutter 12 in a bent state, an inner cutter 16 which shaves whiskers by performing a reciprocating motion while contacting the inner surface of the outer cutter 12, a main body case 24 which contains therein a power supply (a battery in this example) 18 and an electric motor 20 and which has an on-off switch 22 provided on its outer surface, and a driving mechanism 28 which is disposed on the upper surface of the main body case 24 and causes the inner cutter 16 to make a reciprocating motion by converting the rotational motion of the output shaft 26 of the electric motor 20 into a linear motion. The holding frame 14 is removably attached to the upper surface of the main body case 24, and it covers the inner cutter 16 while bending and holding the outer cutter 12. The attachment and detachment mechanism for this holding frame 14 is obtained from, for example, hooks 30 installed on both side surfaces of the holding frame 14 so that they are engaged with engaging grooves 32 formed in both sides of the upper surface of the main body case 24.

Next, the structure of the inner cutter 16 will be described in detail.

The inner cutter 16 consists of a pair of supporting wall sections 16a, which are disposed so as to face each other, and a plurality of small cutters 16b, which have an inverted U cross-sectional shape and are disposed side by side along the direction of length of the supporting wall sections 16a between the upper ends of the supporting wall sections 16a.

The inner cutter 16 is manufactured by, for instance, the following manner: a metal plate is bent into an inverted U cross-sectional shape, and a plurality of slits 16c which cut across the direction of length A of the bent portion B of the metal plate are formed at intervals in this bent portion B. The areas with an inverted U shape that remain in the bent portion B after such a cutting form the small cutters 16b. Also, a pair of extended portions C positioned at the bent tip ends of the metal plate, i. e., the portions other than the bent portion, form a pair of supporting wall sections 16a that face each other.

To the pair of supporting wall sections 16a of the inner cutter 16, connecting pins 34, a connecting block 40, etc. are attached, so that the pair of supporting wall sections 16a are connected to each other. More specifically, as shown in FIG. 19, the connecting pins 34 are attached to the pair of supporting wall sections 16a of the inner cutter 16 so as to maintain the shape of the inner cutter 16 as an inverted U cross-sectional shape. Also, as shown in FIG. 20, the connecting block 40 is made of a synthetic resin and has a slit 38 formed in its lower surface so that the slit 38 engages an

eccentric pin 36 which is coupled to the output shaft 26 of the electric motor 20 and forms a part of the driving mechanism 28.

However, the following problems arise in the above-described conventional inner cutter for a reciprocating electric shaver:

The shaved whiskers enter the interior of the inverted-U-shaped inner cutter 16 and accumulate on the upper surface of the main body case 24.

When these whiskers are to be cleaned away, the whiskers that have accumulated on the upper surface of the main body case 24 must be swept away by a brush, etc. In addition, since whiskers also adhere to the inner surfaces of the inner cutter 16, i. e., they adhere to the inner surfaces of the small cutters 16b and to the facing inner surfaces of the pair of supporting wall sections 16a, these adhering whiskers must be swept away by a brush.

However, the above-described connecting pins 34 and connecting block 40 attached between the pair of supporting wall sections 16a of the inner cutter 16 constitute an obstacle, and the brush cannot be moved along the supporting wall sections 16a. Accordingly, cleaning of the inner surfaces of the small cutters 16b and the facing inner surfaces of the pair of supporting wall sections 16a by a brush is difficult, and considerable time is required for such cleaning.

SUMMARY OF THE INVENTION

Accordingly, the present invention is devised so as to solve the above-described problems. The object of the present invention is to provide an inner cutter for a reciprocating electric shaver and a reciprocating electric shaver which allows easy cleaning of the interior of the inner cutter.

In order to accomplish the above-described object, the inner cutter according to the present invention is for a reciprocating electric shaver wherein the inner cutter is comprised of a pair of supporting wall sections that are disposed opposite to each other, and small cutters with an inverted U cross-sectional shape which are disposed between the upper ends of the pair of supporting wall sections so as to be along the direction of length of the supporting wall sections; and the inner cutter of the present invention is characterized in that only the small cutters are disposed between the pair of supporting wall sections.

In this structure, when whiskers adhering to the inner surface of the inner cutter, i. e., the inner surfaces of the small cutters and the facing inner surfaces of the pair of supporting wall sections, are to be cleaned away by a brush, cleaning can be continuously accomplished from one end to the other while the brush is freely moved through the interior space of the inner cutter which has a bent external shape overall. Accordingly, cleaning is easily and reliably accomplished for places which are difficult to reach with the brush as a result of interference by the connecting pins and connecting block in cases where such connecting pins and connecting block are provided as in conventional devices.

Furthermore, the concrete structure of the inner cutter is as follows: the pair of supporting wall sections are formed by a pair of oppositely extended portions of a metal plate which is bent in two so that the bent portion of the metal plate has an inverted U shape in cross section, and the small cutters are formed by opening a plurality of slits that cut across the direction of length of the bent portion at intervals in the bent portion.

Furthermore, the inner cutter according to the present invention is for a reciprocating electric shaver wherein the

3

inner cutter is comprised of a pair of supporting wall sections that are disposed opposite to each other, and small cutters with an inverted U cross-sectional shape which are disposed between the upper ends of the pair of supporting wall sections and being disposed along the direction of length of the supporting wall sections; and in the present invention, only the small cutters and connecting arches which are formed with the same cross-sectional shape as the small cutters are disposed side by side between the pair of supporting wall sections.

In this structure, the connecting arches are disposed between the pair of supporting wall sections in addition to the small cutters. Accordingly, the strength of the inner cutter as a whole is improved compared to the inner cutter with only the small cutters provided.

Furthermore, the pair of supporting wall sections and connecting arches can be integrally molded using a synthetic resin material, and the small cutters are attached between the pair of supporting wall sections by insert molding. With this structure, manufacture can easily be accomplished, and the strength of the inner cutter as a whole is improved.

Furthermore, in the above-described inner cutter for a reciprocating electric shaver, it is possible the chamfer the corners of the inner surfaces of the small cutters that have no connection with the cutting of whiskers by the inner and outer cutters. As a result, the brush is prevented from being caught by the chamfered corners, and cleaning can be accomplished smoothly.

Furthermore, the reciprocating electric shaver according to the present invention is characterized in that the shaver is equipped with the above-described inner cutter, a mesh-form outer cutter bent in an inverted U cross-sectional shape so that its inner surface contacts the outer surface of the inner cutter, and a driving mechanism provided so as to cause the inner cutter to perform a reciprocating motion relative to the mesh-form outer cutter along the direction of length of the supporting wall sections.

With this structure, it is possible to provide a reciprocating electric shaver in which whiskers adhering to the inner cutter can easily be cleaned away.

BRIEF DESCRIPTION OF THE DRAWINGS

FIG. 1 is an enlarged sectional view showing a part of the structure of an electric shaver which has the inner cutter for a reciprocating electric shaver according to the present invention;

FIG. 2 is a front view which shows the structure of a first embodiment of the inner cutter for a reciprocating electric shaver according to the present invention;

FIG. 3 is a side view of FIG. 2;

FIG. 4 is a plan view illustrating a case in which the slits and small cutters shown in FIG. 2 are formed at an oblique angle;

FIG. 5 is a front view which shows the structure of a second embodiment of the inner cutter for a reciprocating electric shaver according to the present invention;

FIG. 6 is a front view which shows another example of the structure of the inner cutter for a reciprocating electric shaver according to the second embodiment;

FIG. 7 is an arrow view taken along the line H—H in FIG. 6, which indicates an attachment structure that attaches the small cutters to the supporting wall sections;

FIG. 8 is an arrow view taken along the line J—J in FIG. 6, which indicates a connecting structure that connects the connecting arches and the supporting wall sections;

4

FIG. 9 is a front view which shows the structure of the vibrator and connecting base that constitute a part of the inner cutter driving mechanism;

FIG. 10 is a plan view of FIG. 9;

FIG. 11 is a front view of the essential portion in the connected state of the inner cutter in FIG. 9;

FIG. 12 is a front view which shows a different structure of the vibrator and connecting base that constitute a part of the driving mechs of the inner cutter;

FIG. 13 is a plan view of FIG. 12;

FIG. 14 is a side view of FIG. 12;

FIG. 15 is a front view of the essential portions in the connected state of the inner cutter in FIG. 12;

FIG. 16 is an enlarged perspective view of the essential portions in the corner portions of the inner surfaces of the small cutters of the inner cutter;

FIG. 17 is a front view showing the structure of another embodiment of the inner cutter for a reciprocating electric shaver according to the present invention;

FIG. 18 is a front view showing the structure of another embodiment of the inner cutter for a reciprocating electric shaver according to the present invention;

FIG. 19 is an exploded perspective view showing the structure of a reciprocating electric shaver which has a conventional inner cutter, and

FIG. 20 is a perspective view showing the structure of another example of a conventional inner cutter.

DETAILED DESCRIPTION OF THE PREFERRED EMBODIMENTS

Below, a preferred embodiment of the inner cutter for a reciprocating electric shaver of the present invention will be described in detail with reference to the accompanying drawings. Constituting elements which are the same as in the above-described conventional example are labeled with the same reference numerals, and a detailed description of such elements is omitted.

First Embodiment

First, an outline of the overall structure of the reciprocating electric shaver **50** will be described with reference to FIG. 1.

The electric shaver **50** comprises: a mesh-form outer cutter **12** which is formed from a thin metal plate and has openings in the form of eyes of a mesh; a holding frame **14** which holds this outer cutter **12** in a bent state; an inner cutter **52** which shaves whiskers by making a reciprocating motion while contacting the inner surface of the outer cutter **12**; a main body case **24** which contains a battery **18** (a power source) and electric motor **20**, etc. and has an on-off switch (not shown) mounted on its outer surface; and a driving mechanism **28** which protrudes from the upper surface of the main body case **24**, connects the output shaft **26** of the electric motor **20** and the inner cutter **52**, and converts the rotational motion of the electric motor **20** into a reciprocating motion for the inner cutter **52**.

The holding frame **14** is removably attached to the upper surface of the main body case **24**, so that the holding frame **14** covers the inner cutter **52** while bending and holding the outer cutter **12**.

Various structures may be used for the driving mechanism **28**. In one example used in this embodiment, the driving mechanism **28** is constructed from a vibrator **54**, a connecting base **56** which is installed on the upper surface of the

vibrator **54** and to which the inner cutter **52** is connected, and a linking member **60** which connects a first shaft **58** installed on the undersurface of the vibrator **54** with an eccentric pin **36** attached to the output shaft **26** of the electric motor **20**. In this structure, the rotational motion of the output shaft **26** is converted into a reciprocating linear motion of the vibrator **54** via the linking member **60**.

Various structures may also be employed for the removing mechanism for removably attaching the holding frame **14** (to which the outer cutter **12** is attached) to the main body case **24**. One example is shown in FIG. 1. In this mechanism, an engaging element **62** is attached so as to freely protrude and retract in the lateral direction along the side surface of the Upper Portion of the main body case **24**, and a spring **64** is provided so as to constantly drive this engaging element **62** in the direction of protrusion; and an engaging projection **66** that engages with the engaging element **62** is provided on the inner surface of the holding frame **14**.

In this removing mechanism, when the holding frame **14** is press-fitted in the main body case **24** at the time that the holding frame **14** is mounted, the engaging projection **66** rides over the engaging element **62** while pushing the engaging element **62** into the main body case **24** against the driving force of the spring **64**. The engaging projection **66** then engages with the engaging element **62**, so that mounting is completed. The mounted holding frame **14** cannot easily be detached from the main body case **24** since the engaging element **62** protrude due to the driving force of the spring **64**.

The holding frame **14** is detached from the main body case **24** as follows: the holding frame **14** is conversely pulled in the non-engagement direction, this causes the engaging projection **66** to ride over the engaging element **62** while pushing the engaging element **62** into the main body case **24** against the force of the spring **64**, and the holding frame **14** can be removed accordingly.

Next, a detailed structure of the inner cutter **52**, which is the characterizing feature of the present invention, will be described with reference to FIGS. 2 and 3.

The inner cutter **52** consists of a pair of supporting wall sections **52a** (which is T-shaped in this embodiment), and a plurality of small cutters **52b** with an inverted U cross-sectional shape. The plurality of small cutters **52b** are disposed between the upper ends of the supporting wall sections **52a** and are lined up side by side along the direction of length A of the supporting wall sections **52a**. The method for manufacturing this inner cutter **52** is similar to the method used in the prior art inner cutter: a metal plate is bent into an inverted U cross-sectional shape, and a plurality of slits **52c** which cut across the direction of length A of the bent portion B are formed at intervals (fixed intervals in FIG. 2) in the bent portion B, so that the inverted-U-shaped thin parts that remain in the bent portion **13** form the small cutters **52b**. The pair of extended portions C positioned at the bent tip ends of the metal plate are formed as the pair of supporting wall sections **52a**.

The slits **52c** may be oriented in the direction perpendicular to the direction of length A of the bent portion B. Alternatively, the slits **52c** may be formed at a slightly oblique angle with respect to the direction perpendicular to the direction of length A of the bent portion B.

Here, the difference between the inner cutter **52** of the present invention and the prior art inner cutter **16** is that except for the small cutters **52b**, no members which span the gap between the supporting wall sections **52a** of the inner cutter **52**, such as the connecting pins **34**, connecting block

40, etc. used in the prior art inner cutter **16**, are provided on the supporting wall sections **52a** of the inner cutter of the present invention (as shown in FIG. 3).

Since the inner cutter **52** has the structure as described above, when whiskers adhering to the inner surface of the inner cutter **52**, i. e., the inner surfaces D of the small cutters **52b** and the facing inner surfaces E of the pair of supporting wall sections **52a**, are to be cleaned away by a brush, the user can continuously clean the inner cutter **52** from one end to the other while freely moving the cleaning brush in the internal space **68** of the inner cutter **52**, which has a bent shape as a whole. Accordingly, inside positions, which are difficult to reach when the connecting block **40** and connecting pins **34** are present (as in the prior art inner cutter) because of the interference of such elements with the brush, can be easily and securely cleaned.

SECOND EMBODIMENT

In the inner cutter **52** of the above-described embodiment, only the small cutters **52b** are disposed between the pair of supporting wall sections **52a**. However, the inner cutter **52** having the structure as shown in FIGS. 5 and 6 is also possible.

The inner cutter **52** shown in FIG. 5 is comprised of: a pair of supporting wall sections **52a** which are disposed so as to face each other; a plurality of small cutters **52b** which are of an inverted U cross-sectional shape disposed between the upper ends of the supporting wall sections **52a** and lined up side by side along the direction of length A of the supporting wall sections **52a**; and connecting arches **70** which has the same cross-sectional shape as the small cutters **52b** and are disposed between the pair of supporting wall sections **52a**.

In other words, only the small cutters **52b** and connecting arches **70** are present between the pair of supporting wall sections **52a** of the inner cutter **52**; and these connecting arches **70** are provided so as to maintain the strength of the connection between the pair of supporting wall sections **52a**. When the inner cutter **52** is manufactured from a single metal plate, a plurality of slits **52c** are, as in the same manufacturing methods as in the prior art and the first embodiment, formed at intervals in the bent portion B of the metal plate that is formed by bending, so that the thin parts with an inverted U shape that remain in the bent portion B, after the cutting, form the small cutters **52b**; and at the same time, the interval F between some of the slits **52c**, preferably the interval F between both ends of the bent portion B and the slits **52c** located closest to such ends, is formed larger than the thickness G of the small cutters **52b**, so that these thick areas form the connecting arches **70**.

In the above embodiment, one connecting arch **70** is installed at each end of the row of small cutters **52b**. However, when greater strength is desired in the inner cutter **52**, connecting arches **70** may be formed between the small cutters **52b**, thus forming the connecting arches **70** in greater numbers.

The pair of extended portions C outside the bent portion B of the metal plate are formed as a pair of supporting wall sections **52a** that face each other as in the first embodiment.

In this structure, the connecting arches **70** which have a greater rigidity than the small cutters **52b** are disposed between the pair of supporting wall sections **52a** in addition to the small cutters **52b**. Accordingly, the inner cutter **52** has an increased strength compared to a case in which only the small cutters **52** are so disposed.

The supporting wall sections **52a** of the inner cutter **52** can be obtained by molding, using a synthetic resin material.

In this manufacturing method, the pair of supporting wall sections **52a** and the connecting arches **70** are integrally molded with a synthetic resin material, after which the small cutters **52b** are securely attached to the supporting wall sections **52a** by insert molding as shown in FIGS. 6 through 8. FIG. 7 is a sectional view taken along the line H—H in FIG. 6, showing that both end portions of each small cutter **52b** which is formed in an arc shape (inverted U shape) are embedded in the upper end portions of the supporting wall sections **52a** formed from a synthetic resin material. FIG. 8 is a sectional view taken along the line J—J in FIG. 6, showing the cross-sectional shape of the connecting arches **70**. It is seen that this shape is substantially the same as the cross-sectional shape of the small cutters **52b**.

It is necessary that the outer surfaces of the small cutters **52b** are moved in contact with the inner surface of the outer cutter **12**. Accordingly, a cross-sectional shape in which the outer surfaces of the connecting arches **70** protrude beyond the outer surfaces of the small cutters **52b** is not allowed. As a result, the term “substantially the same cross-sectional shape” referred to above naturally includes cases in which the cross-sectional shape of the connecting arches **70** is the same as the cross-sectional shape of the small cutters **52b**. In addition, this term also includes cross-sectional shapes in which the outer surfaces of the connecting arches **70** are located further inward than the outer surfaces of the small cutters **52b** and are formed substantially in the shape of an inverted U even if the cross-sectional shapes are not exactly the same.

Accordingly, as in the first embodiment, the inner cutter **52** as a whole is formed in an inverted U cross-sectional shape as shown in FIG. 3 when viewed from the side (i. e., from the direction of one of the end portions of the bent portion B). Consequently, when whiskers are cleaned away by a brush, the brush is moved through the internal space **68** of the inner cutter **52**, and whiskers adhering to the inner surface of the inner cutter **52**, i. e., the inner surfaces D of the small cutters **52b** and the facing inner surfaces E of the pair of supporting wall sections **52a**, can be easily and reliably cleaned away.

Next, the linking structure between the inner cutter **52** and the driving mechanism **28** in the above-described first and second embodiments will be described with reference to FIGS. 9 through 11.

Since the pair of supporting wall sections **52a** of the inner cutter **52** of the present invention are not connected to each other except by the small cutters **52b** and connecting arches **70** formed in the bent portion B, both of the supporting wall sections **52a** need to be linked to the driving mechanism **28**.

Accordingly, projecting areas **52e** are formed on both side surfaces of the end portions (lower end portions in FIGS. 2, 5 and 6) of supporting wall sections **52a** of the inner cutter **52** so as to be located on the side of the driving mechanism **28**, and these end portions are formed in an inverted T shape.

Meanwhile, as shown in FIGS. 9 and 10, a connecting base **56** which is to be connected to the inverted-T-shaped end portions of the pair of supporting wall sections **52a** is provided on the upper surface of the vibrator **54** which forms a part of the driving mechanism **28**. This connecting base **56** is in the shape of a rectangular parallelepiped, and a cylindrical recess **74** in which a coil spring **72** is installed from above is formed in the central portion of the connecting base **56**, and also grooves **76** which extend upward and downward so as to allow the insertion of the inverted-T-shaped end portions of the pair of supporting wall sections **52a** are formed in both side surfaces so that the grooves **76** are

located on either side of the cylindrical recess **74**. Furthermore, connecting projections **76a** which engage with the projecting areas **52e** on both side surfaces of the end portions of the supporting wall sections **52a** are formed on the facing side surfaces running upward and downward inside the respective grooves **76**.

Moreover, the spacing of the respective grooves **76** is set to be narrower than the diameter of the coil spring **72** so that it matches the spacing of the supporting wall sections **52a** of the inner cutter **52**. Accordingly, the respective grooves **76** communicate with the cylindrical recess **74**, and portions of the coil spring **72** mounted in the cylindrical recess **74** protrude into the respective grooves **76**.

When linking the inner cutter **52** to the driving mechanism **28**, the inverted-T-shaped lower end portions of the supporting wall sections **52a** located on the side of the driving mechanism **28** are first inserted into the respective grooves **76** of the connecting base **56**, and the inner cutter **52** is pushed toward the connecting base **56**.

In this case, the lower end portions of the supporting wall sections **52a** contact a part of the coil spring **72** mounted in the connecting base **56**. However, these lower end portions are pushed inward while compressing the coil spring **72**, so that the projecting areas **52e** ride over the connecting projections **76a** and are caused to move further downward. As a result, the projecting areas **52e** engage with the connecting projections **76a** as shown in FIG. 11, so that the inner cutter **52** is connected to the connecting base **56**. In this state, the inner cutter **52** is constantly urged upward by the coil spring **72**. Accordingly, even when the inner cutter **52** is caused to perform a reciprocating motion by the driving mechanism **28**, there is no play in the vertical direction. Furthermore, even in cases where a downward pressing force is applied from the skin via the outer cutter **12** during shaving, the inner cutter **52** can absorb this pressing force by being moved downward, and a tight fit against the skin is also maintained.

The inner cutter **52** can be removed easily from the connecting base **56**. The inner cutter **52** is pulled in the direction which separates the inner cutter **52** from the connecting base **56**, so that the engagement between the projecting areas **52e** and connecting projections **76a** is released.

The structure shown in FIGS. 12 through 14 may be employed as for the connecting base **56**.

The connecting base **56** is comprised of: two elastic members **78** which are disposed upright with a specified interval in between so that the spacing of the outside surfaces **78a** matches the spacing of the facing inner surfaces of the supporting wall sections **52a** of the inner cutter **52**; connecting projections **78b** which protrude laterally at intermediate points of the outside surfaces **78a** of both elastic members **78**; and a coil spring **72** which is fitted over the respective connecting projections **78b** and the two elastic members **78**. The two elastic members **78** may be formed by cutting a specified distance downward into the center of a columnar body from the upper surface as in the present embodiment, or the elastic members **78** can be directly installed upright on the connecting base **56**.

Slots **52f** into which the connecting projections **78b** are inserted are formed in the lower end portions of the supporting wall sections **52a** of the inner cutter **52** (see FIG. 15).

The inner cutter **52** is attached to the connecting base **56** in the following manner:

The inner cutter **52** is pushed inward toward the connecting base **56** while the lower end portions of the supporting

wall sections 52a are positioned so that their inner surfaces face the respective outside surfaces 78a of the two elastic members 78. In this case, the lower end portions of the supporting wall sections 52a contact the coil spring 72 mounted in the connecting base 56 but are pushed inward while compressing the coil spring 72.

Next, when the lower end portions of the supporting wall sections 52a contact the connecting projections 78b, the inner cutter 52 is pushed further downward so that the two elastic members 78 are pushed to tilt inward. As a result, the connecting projections 78b is moved toward the inner surfaces of the lower end portions of the supporting wall sections 52a; and when these connecting projections 78b reach the interiors of the slots 52f, the respective elastic members 78 return to their original positions as a result of their own elastic force. The connecting projections 78b are thus inserted into the slots 52f. As a result, the inner cutter 52 is connected to the connecting base 56.

When removing the inner cutter 52 from the connecting base 56, it is only necessary to pull the inner cutter 52 away from the connecting base 56 while applying a force. When the inner cutter 52 is thus pulled away, the connecting projections 78b contact the inner circumferential rims of the slots 52f. However, the respective elastic members 78 which receive a force from the connecting projections 78b tilt inward so that the connecting projections 78b are removed from the slots 52f.

In the above-described inner cutter for a reciprocating electric shaver 52, the corners D1 of the inner surfaces D of the small cutters 52b, which do not contact the outer cutter 12 and have no connection with the shaving action of whiskers, are chamfered as shown in FIG. 16. As a result, if the brush should contact these corners during cleaning, the brush is not caught on the corners, and cleaning can be smoothly performed. This corner chamfering can be accomplished by pressing or discharge working.

The structure of the inner cutter of the present invention is not limited to the structures shown in FIGS. 2, 4, 5 and 6. For example, the present invention is applicable to an inner cutter in which the slits 52c are formed at an oblique angle, and the small cutters 52b are inclined by a specified angle of α with respect to the direction perpendicular to the direction of length A of the supporting wall sections 52a, as shown in FIG. 17. Furthermore, the present invention is further applicable to an inner cutter in which the spacing of the slits 52c varies along the direction of length A of the supporting wall sections 52a, so that the small cutters 52b are formed with a varied spacing as shown in FIG. 18.

Various preferred embodiments of the present invention are described above. However, the present invention is not limited to the embodiments described above. It goes without saying that numerous modifications may be made without departing from the spirit of the invention.

When the inner cutter according to the present invention as claimed in claim 1 or 2 is used in a reciprocating electric shaver, the following merit is obtained. When cleaning away, with a brush, whiskers adhering to the inner surface of the inner cutter, i. e., the inner surfaces of the small cutters and the facing inner surfaces of the supporting wall sections, such cleaning is difficult in conventional cutters because the connecting pins and connecting block form obstacles between the pair of supporting wall sections and interfere with the movement of the brush. However, in the present invention, since only the small cutters are disposed between the supporting wall sections and the inner cutter is formed in an inverted U as a whole, whiskers adhering to the inner

surface of the inner cutter can be continuously cleaned away from one end of the inner cutter to the other while the brush is moved through the internal space of the inner cutter. Accordingly, cleaning can be performed in a simple and reliable manner.

Furthermore, when the inner cutter according to the present invention as claimed in claim 3 or 4 is used in a reciprocating electric shaver, the following merits are obtained. Since only connecting arches which have the same cross-sectional shape as the small cutters are disposed between the supporting wall sections besides the small cutters, the brush can be moved through the internal space of the inner cutter, and whiskers adhering to the inner surface of the inner cutter can easily be cleaned away. In addition, since the connecting arches are disposed between the supporting wall sections, the inner cutter can have an overall increased strength compared to a case in which only the small cutters are so disposed.

Furthermore, when a reciprocating electric shaver equipped with one of the above inner cutters is used, the following merits are obtained. Since cleaning of the cutter can easily be performed, the user does not feel any resistance to the task of cleaning away the accumulated whiskers. Accordingly, cleaning of the electric shaver is frequently performed, and whiskers are shaved with the outer cutter and inner cutter in a clean state. Consequently, the sharpness and feeling of the electric shaver are improved, and the deterioration of the outer and inner cutters themselves is retarded.

What is claimed is:

1. A reciprocating electric shaver including a reciprocating means, a connecting member provided on said reciprocating means and an inner cutter detachably coupled to said connecting member, said inner cutter consisting of a pair of supporting wall sections that are disposed opposite and parallel to each other, small cutters that have an inverted U cross-sectional shape disposed between upper ends of said pair of supporting wall sections so that a plurality of said small cutters are disposed along a longitudinal direction of length of said pair of supporting wall sections and a mounting projection provided on each of said pair of supporting wall sections projecting in an opposite direction than said small cutters for detachably coupling said inner cutter to said connecting member, wherein said inner cutter is further characterized in that:

only said small cutters are disposed between said pair of supporting wall sections;

whereby said inner cutter is detachable from said connecting member for easy cleaning of inner and outer surfaces of said inner cutter.

2. The electric shaver according claim 1, characterized in that said pair of supporting wall sections consists of a pair of oppositely extended portions of a metal plate which is bent in two so as to form a bent portion that has an inverted U shape in cross section, and said small cutters consist of a plurality of slits that cut across a direction of length of said bent portion at intervals in said bent portion.

3. A reciprocating electric shaver including a reciprocating means, a connecting member coupled to said reciprocating means and an inner cutter detachably coupled to said connecting member, said inner cutter consisting of a pair of supporting wall sections that are disposed opposite and parallel to each other, small cutters that have an inverted U cross-sectional shape disposed between upper ends of said pair of supporting wall sections so that a plurality of said small cutters are disposed along a longitudinal direction of length of said pair of supporting wall sections and a mounting projection is provided on each of said supporting wall

11

sections projecting in an opposite direction than said small cutters for detachably coupling said inner cutter to said connecting member, wherein said inner cutter is further characterized in that:

only said small cutters with said inverted U cross-sectional shape are disposed side by side between said pair of supporting wall sections;

whereby said inner cutter is detachably coupled from said connecting member for easy cleaning of inner and outer surfaces of said inner cutter.

4. The cutter for a reciprocating electric shaver according to claim 3, characterized in that said pair of supporting wall sections and said connecting arches are integrally molded using a synthetic resin material, and said small cutters are attached between said pair of supporting wall sections by insert molding.

5. The cutter for a reciprocating electric shaver according to claim 1, 2, 3 or 4, characterized in that corners of inner surfaces of said small cutters are chamfered.

6. A reciprocating electric shaver characterized in that said shaver is equipped with:

an inner cutter for a reciprocating electric shaver according to claim 1, 2, 3 or 4;

a mesh-form outer cutter which is bent in an inverted U cross-sectional shape so that an inner surface thereof contacts an outer surface of said inner cutter; and

a driving mechanism which causes said inner cutter to perform a reciprocating motion relative to said mesh-form outer cutter along a direction of length of said supporting wall sections.

7. A reciprocating electric shaver characterized in that said shaver is equipped with:

an inner cutter for a reciprocating electric shaver according to claim 5;

12

a mesh-form outer cutter which is bent in an inverted U cross-sectional shape so that an inner surface thereof contacts an outer surface of said inner cutter; and

a driving mechanism which causes said inner cutter to perform a reciprocating motion relative to said mesh-form outer cutter along a direction of length of said supporting wall sections.

8. A reciprocating electric having according to claim 1 wherein said connecting member comprises:

a rectangular parallel piped base coupled to said reciprocating means;

a cylindrical hole provided in a top surface of said base; a coil spring provided inside said cylindrical hole;

a pair of grooves provided in parallel in and extending longitudinally of said base; and

connecting projections provided in said pair of grooves; whereby said mounting projection provided on each of said supporting wall sections is snap engaged with said base by said mounting projection extending into said groove.

9. A reciprocating electric shaver according to claim 1 wherein said connecting member comprises:

an upwardly extending base coupled to said reciprocating means;

a coil spring provided around said base; and

connecting projections extending outwardly from said base;

whereby said mounting projection provided on each supporting wall is detachably coupled to said base via said connecting projections.

* * * * *