



(86) Date de dépôt PCT/PCT Filing Date: 2005/09/07
 (87) Date publication PCT/PCT Publication Date: 2006/03/16
 (85) Entrée phase nationale/National Entry: 2007/03/09
 (86) N° demande PCT/PCT Application No.: AT 2005/000358
 (87) N° publication PCT/PCT Publication No.: 2006/026800
 (30) Priorité/Priority: 2004/09/09 (ATA 1508/2004)

(51) Cl.Int./Int.Cl. *B42D 9/06* (2006.01)
 (71) Demandeur/Applicant:
 QUIDENUS GMBH, AT
 (72) Inventeur/Inventor:
 JAKES, ALFRED, AT
 (74) Agent: EQUINOX

(54) Titre : DISPOSITIF POUR ELEVER UNE FEUILLE

(54) Title: SHEET LIFTING DEVICE WITH AN ACUTE-ANGLE ARRANGED PIVOTAL AXIS OF THE MOTOR

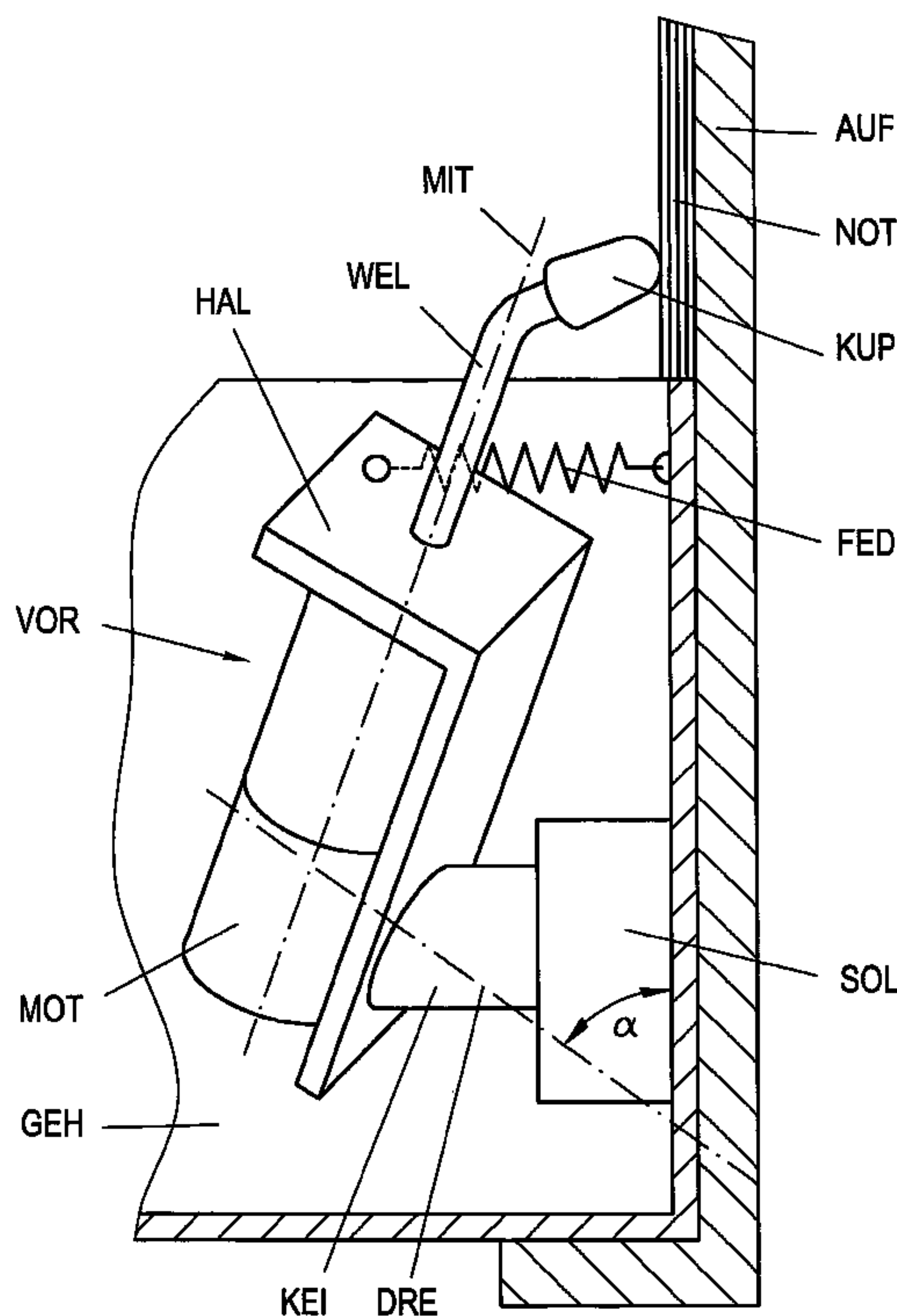

(57) Abrégé/Abstract:

The device (VOR) for lifting a sheet (BLA) of a stack of sheets (NOT), particularly of a music notebook, having a binding (FAL) or stitching, comprises a drive (MOT) for at least one lifting element (ANH) and comprises a supporting surface (AUF) for the sheet (BLA). The at least one lifting element (ANH) can be driven by the drive (MOT) via a drive shaft (WEL) in a rotational motion about said drive shaft (WEL), and the drive (MOT) is mounted in a manner that enables it to rotated about at least one rotation axis (DRE) that is at an acute angle α to the plane of the supporting surface (AUF).

ABSTRACT

The device (VOR) for lifting a sheet (BLA) of a stack of sheets (NOT), particularly of a music notebook, having a binding (FAL) or stitching, comprises a drive (MOT) for at least one lifting element (ANH) and comprises a supporting surface (AUF) for the sheet (BLA). The at least one lifting element (ANH) can be driven by the drive (MOT) via a drive shaft (WEL) in a rotational motion about said drive shaft (WEL), and the drive (MOT) is mounted in a manner that enables it to rotated about at least one rotation axis (DRE) that is at an acute angle α to the plane of the supporting surface (AUF).

(Fig. 2)

SHEET LIFTING DEVICE WITH AN ACUTE-ANGLE ARRANGED PIVOTAL AXIS OF THE MOTOR

The invention concerns a device for the lifting of a sheet from a pile of bound or stapled sheets, in particular sheet music, with a drive mechanism for at least one lifting unit and a surface for the sheet, whereby it is at least a lifting unit that can be activated by a driveshaft of the drive mechanism in a rotational movement around the driveshaft.

Devices of this kind are, for example, well known from the applicant's WO 00/35680.

The device in question facilitates the turning over of pages of books, sheet music and the like. It has a supporting surface for a book, sheet music and the like, with a shaft to which two arms are attached, placed in a normal manner and directly opposite each other, so that they are distanced parallel to the carrier unit, with a motor for the shaft and a lifting device on the one side, with a second lifting device symmetrical to the shaft, with at least one motor for both lifting devices, which is independent from the motor for the shaft, and that the shaft can be propelled in both directions by the motor.

In the DE 8 028 569 U a sheet turning device is described, whose turning handle can move diagonal to the folding crease over a desk, with the distance between the initial size/gauge of the sheet pile and the stroke of the sheet lifting mechanism.

The drawback of these devices are that only a small number of sheets can be turned over securely and without interruption, because of the fact that the height of the sheet pile, whose sheets are to be turned over, is continuously reduced and thus the reliable lifting of the top sheet of the sheet pile by the sheet lifting device can not be guaranteed.

The DE 201 15 040 U1 pertains to a device, mentioned at the beginning, for turning individual sheets from multi-sheet documents, in particular bound or stapled sheet music, with a supporting surface, a reversible electrical motor,

2

whose output shaft is connected to a swinging arm moving back and forth between a resting point and a turning point, and moving along with the swinging arm a friction roller, that presses on to the sheet to be turned over during the swinging movement, whereby the friction roller is distanced from the longitudinal axis of the pendulum arm by a swivel arm, that causes the friction roller to, at least at section 2 of the swinging motion of the swinging arm with a superimposed swivel motion, to move the friction roller to the sheet to be turned over and to accelerate the turning over of the sheet relative to the swinging motion of the swinging arm.

The drawback of this device is its complicated structure on the one hand, on the other hand more energy is needed for the movement of a page of the document partly due to the traction movement of the friction roller.

Therefore, the objective of the invention is to create a device, that will overcome the above-mentioned disadvantages and allow the secure lifting of the top page/sheet of a pile of bound sheets, whereby the sheet pile consists of any height and the device does not need to be readjusted.

This objective is reached/solved by a device of the kind mentioned at the beginning, by the fact that the drive mechanism pivot-mounted around at least one axis, which is located at an acute angle on the plane of the supporting surface. It was shown that the movement of a sheet from the document is possible by a pushing motion with less consumption of energy, which also reduces the mechanical wear and tear of the material.

Furthermore, a central axis that runs through the power shaft comprises of an acute angle β to the driveshaft that is turned towards the power shaft. The orthogonal parallel projection of the central axis of the power shaft on the plane of the supporting surface, in turn, comprises of an acute angle with an edge of the sheet running perpendicular to the binding, with the power shaft pointing away from the binding.

Each angle with a value of lower than 90° is called an acute angle.

3

Due to the slanted angle position of the device in relation to the supporting surface and thus sheet surface, the sheet can be turned over securely. It proved particularly advantageous if angle α has a value between 50° and 70° , angle β a value between 45° and 90° , and here in particular a value of $75^\circ \pm 5^\circ$, and angle γ a value from 30° to 60° . An ideal angle for γ is 45° .

In a preferential embodiment of the invention the lifting unit grips the sheet in the corner. Due to the slanted angle position of the device described above, the lifting of the sheet by the lifting unit takes place in a motion similar to the turning over of a sheet with a finger.

In an economical embodiment of the invention it is a lifting unit with the driveshaft in one piece. In another option it is a lifting unit bolted to the driveshaft or connected by a plug-and-socket connection. This has the advantage that the lifting unit can simply be exchanged if necessary.

To ensure a secure lifting of the sheet, at least one lifting unit consists of an end piece that makes contact with the sheet.

It is particularly advantageous, if the end piece consists of a flexible material and the moreover one of a material with a high coefficient of friction to the sheet.

In another embodiment the lifting unit is manufactured from flexible material. Thus the device gains a high flexibility in view to the height of the sheet pile.

The drive mechanism is at least able to swivel against the reset force by one reset unit, thus the deflection of the drive mechanism is limited, and the end piece remains in the contact with the surface of the sheet to be lifted. At the same time the reset unit, for example a steel spring, defines the contact pressure, with which the end piece presses against the sheet.

The invention proved itself in a mechanism for the turning over of sheets from a sheet pile, which exhibits a device according to the invention as well as at least a sheet turning device for the turning of a sheet lifted by the device.

4

By means of a non-restrictive example, with associated figures, the invention is described in the following. The figures show:

Figures 1a-c a music stand with an integrated turning over device for sheet music utilizing a device according to the invention for the lifting and/or separating of a sheet, as well as a schematic representation of the turning over action;

Figure 2 the device for the lifting and/or separating of a sheet from Figure 1 in a detailed view from the side without front cover;

Figure 3 the device for the lifting and/or separating of a sheet from Figure 1 in a detailed view from the front without front cover;

Figure 4 the device for the lifting and/or separating of a sheet from Figure 1 in a detailed view from above without front cover;

Figure 5 the course of motion of the device from Figures 2-4 with the lifting of a sheet.

Figures 1a-c illustrates the use of the device according to the invention for the turning over of sheet music NOT. For that purpose the sheet music NOT is laid on a music stand PUL, to which a housing GEH is attached. For this purpose the music stand PUL exhibits a supporting surface AUF, which is designed as a rectangular plate for example. The supporting surface can have any form imaginable, as long as it has a flat surface for the placing of a book, booklet, etc. Likewise the music stand PUL can consist of a commercial music stand, to which the housing GEH is attached.

The housing GEH accommodates a device for the lifting and/or separating of a sheet as well as a sheet turning device BWE for turning over the sheet BLA that was lifted off. A power supply plug NET leads into the housing GEH and a cable, which leads to a switch unit, which causes the turning over of the sheet music NOT. For example, the switch is shown as a foot push button TAS.

Turning over of the sheet music NOT takes place by pressing of the foot push button TAS. Firstly a lifting unit ANH moves in a circular movement over the

5

right lower corner one of a top sheet BLA of the sheet music NOT. An end piece KUP on the lifting unit ANH (Figure 2) shifts the right, lower corner of the sheet BLA towards the binding FAL of the sheet music NOT, so that the sheet BLA becomes separated from the sheet underneath. Likewise it is possible for the invention, that the lifting unit ANH grips in another area, preferably another corner or edge of the sheet BLA.

Latest investigations by the inventor showed that it is particularly advantageous if the finger grips the extreme corner area. The further the point of impact is away from the corner point of the page, the higher the adhesive force between the sheet to be lifted and the sheet underneath. Therefore, a bigger force must be applied by the finger on the sheet to be lifted, whereby this again places a stronger mechanical load on the page.

To turn over the lifted sheet BLA, a sheet turning device BWE grips under the curved sheet BLA and turns it over. Sheet turning devices are well-known from the current state of technical development. So, for example, a mechanism as in the WO 00/35680 of the applicant is made known in combination with the available invention as a device that can be used for the turning over of sheets from a bound sheet pile. In this embodiment of the invention the sheet turning device BWE is an arm that executes a swivel movement parallel to the plane of the laid down sheet music NOT, similar to a windshield wiper. This movement is synchronized with the rotation of the lifting unit ANH. In another embodiment of the invention the sheet turning device BWE is for example at the upper edge of the sheet music NOT.

Figures 2 to 4 show the device VOR in schematic form for turning over and/or separation of a sheet BLA. In Figure 2 the device VOR is attached to the housing GEH by a wedge-shaped support KEI and a base SOC. A drive mechanism MOT is attached in a tiltable position by a mounting plate HAL, whereby an axis DRE of the drive mechanism MOT crosses the plane of the supporting surface AUF at an acute angle α , which preferably lies between 50° and 70°.

6

The drive mechanism MOT can be an electrical motor as for example a gear motor or a multiphase motor. In another embodiment of the invention the drive mechanism MOT is not on the mounting plate HAL, but is attached in a direct swivel position.

The axis DRE, more exactly the side turned towards the support KEI, forms an angle with the central axis MIT of the driveshaft WEL in the current embodiment of the invention of approximately 75° . Thus the central axis MIT does not run parallel to the plane of the supporting surface AUF.

The orthogonal parallel projection of the central axis MIT of the driveshaft WEL on the plane of the supporting surface AUF forms an acute angle with an edge of the sheet BLA running perpendicularly to the binding FAL, such that the driveshaft WEL points away from the binding FAL. The angle γ should for most advantageous purposes have a value between 30° and 60° . An angle of $\gamma = 45^\circ$ proved itself as the most advantageous angle during new investigations.

A driveshaft WEL is attached along the central axis MIT to the drive mechanism MOT, either stationary or by a joint. To the driveshaft WEL the lifting unit ANH is attached, whereby the lifting unit ANH, as shown in Figure 3 is set at an angle δ to the driveshaft WEL. Most advantageous for this angle $\delta = 135^\circ$.

The lifting unit ANH shows an end piece KUP, which preferably is manufactured from soft rubber. This possesses a high elasticity, which permits the device VOR, for example, to turn over sheet music of varying thickness securely, without having to correct the distance of the lifting unit ANH to the sheet BLA. Likewise the rubber material exhibits a high friction coefficient to the material from which the sheet BLA is manufactured and which can be for example paper, or even plastic. Foam rubber and natural rubber has proven itself as particularly suitable materials. Likewise the upper surface of the end piece END can be structured, in order to obtain a suitable surface roughness and with it a high friction coefficient.

It is advantageous, if the end piece KUP is attached to the lifting unit ANH in a way to be removable, for example by screws or a socket connection. Thus the end piece KUP can be changed easily if necessary due to wear and tear.

In another embodiment of the invention the lifting unit ANH is manufactured from flexible material, while the end piece KUP is likewise manufactured from either of metal with a high upper surface roughness or of plastic.

Figure 5 illustrates the movement of the lifting unit ANH and the drive mechanism MOT by lifting and/or separating of the sheet BLA. The drive mechanism MOT causes a rotation of the driveshaft WEL around its central axis MIT. Thus the lifting unit ANH moves by a starting position, represented by a dash-dotted line, with its end piece KUP on an essentially circular course in an anti-clockwise direction, until the end piece KUP touches the sheet BLA.

Due to the resistance of the material of the sheet BLA the drive mechanism MOT attached in a pivotal manner to the driveshaft DRE twists, whereby the drive mechanism MOT is regulated such that with resistance motor output is increased up to a fixed maximum level. This swivel movement runs in opposite direction to the sliding movement of the lifting unit ANH and/or its end piece KUP on the sheet BLA to be lifted. The maximum twist of the drive mechanism MOT around the driveshaft DRE is limited by the spring FED. Instead of steel springs other professional reset units can also be used. Thus the adjustment of the pressure with which the end piece KUP touches the material of the sheet BLA takes place.

If the lifting unit ANH moves on, then the friction forces between the end piece KUP and the sheet BLA are larger than those between the top sheet BLA and the sheet pile NOT underneath. Therefore the sheet BLA separates itself from this. The turning device BWE shown in Figure 1 moves between sheet BLA and sheet pile NOT and turn over sheet BLA in a movement parallel to the plane of the sheet music (not shown).

Meanwhile the drive mechanism MOT returned to its starting position and the lifting unit ANH continues to turn as soon as the sheet BLA was gripped by the

sheet turning device BWE, in an anti-clockwise direction, until the initial position is reached again.

In another embodiment of the invention the device, according to the invention, contains a holding down mechanism (not shown). This is, for example, achieved in form of two clips. These clips serve to hold down the pages that curve upwards due to the bookbinding process. It was shown that due to the curving of the pages, higher static friction to each other is exhibited, whereby a higher energy output becomes necessary to move the page to be lifted.

It is most advantageous for the clips to grip at the lower edge of the sheet music on the left and on the right in a distance from the crease. By operating the release, a foot push button in a previous embodiment of the invention, the clips are turned away from its position by a rotational movement by its own drive mechanism, for example an electric motor, so that the movement of the lifting unit described above for the separating of the sheet and the consequent actual turning over of the page can be accomplished unhindered by the sheet turning device.

The embodiment of the invention described here is to be regarded in a non-restrictive way. It is not limited to the lifting of sheets of a booklet or a book, it is equally suitable, for example, for turning over sheets in plastic covers, as commonly used in ring binders.

CLAIMS

1. Device (VOR) for the raising of a sheet (BLA) of a sheet pile (NOT), in particular sheet music, having a binding (FAL), or staples, with a drive mechanism (MOT) for at least one lifting unit (ANH) and a supporting surface (AUF) for the sheet (BLA), whereby the at least one lifting unit (ANH) can be driven by a driveshaft (WEL) of the drive mechanism (MOT) in a rotational movement around the driveshaft (WEL), **characterized in that**

the drive mechanism (MOT) is mounted to rotate around at least one driveshaft (DRE) that is at an acute angle α to the plane of the supporting surface (AUF).
2. Device (VOR) according to claim 1, **characterized in that** one central axis (MIT) running through power shaft (WEL) forms an acute angle β to the driveshaft (DRE), which is turned towards the power shaft (WEL).
3. Device (VOR) according to claim 1 or 2, **characterized in that** the orthogonal parallel projection of the central axis (MIT) of the power shaft (WEL) forms an acute angle γ to the edge of the sheet (BLA) extending perpendicularly to the binding (FAL), on the plane of the supporting surface (AUF), whereby the driveshaft (WEL) points away from the binding (FAL).
4. Device (VOR) according to claim 1, **characterized in that** the angle α exhibits a value between 50° and 70° .

10

5. Device (VOR) according to claim 2, **characterized in that** the angle β exhibits a value between 45° and 90° .
6. Device (VOR) according to claim 2, **characterized in that** the angle β exhibits a value of $75^\circ \pm 5^\circ$.
7. Device (VOR) according to claim 3, **characterized in that** the angle γ exhibits a value from 30° to 60° .
8. Device (VOR) according to any one of the claims 1 to 7, **characterized in that** the lifting unit (ANH) grips in the corner area of a sheet (BLA).
9. Device (VOR) according to any one of the claims 1 to 8, **characterized in that** the at least one lifting unit (ANH) is of one piece with the driveshaft (WEL).
10. Device (VOR) according to any one of the claims 1 to 8, **characterized in that** the at least one lifting unit (ANH) is attached by screws or a socket connection to the driveshaft (WEL).
11. Device (VOR) according to any one of the claims 1 to 10, **characterized in that** the at least one lifting unit (ANH) includes an end piece (KUP) that comes into contact with the sheet (BLA).

12. Device (VOR) according to any one of the claims 1 to 11, **characterized in that** the end piece (KUP) consists of a flexible material.
13. Device (VOR) according to any one of the claims 1 to 12, **characterized in that** the end piece (KUP) consists of a material with a high friction coefficient to the sheet (BLA).
14. Device (VOR) according to any one of the claims 1 to 13, **characterized in that** the at least one lifting unit (ANH) is manufactured from flexible material.
15. Device (VOR) according to any one of the claims 1 to 14, **characterized in that** the drive (MOT) is able to swivel against the reset force of at least one reset unit (FED).
16. Mechanism for turning over of sheets of a sheet pile (NOT), having a device (VOR) according to any one of the claims 1 to 15 as well as at least one sheet turning device (BWE) for turning a sheet (BLA) lifted by the device (VOR).

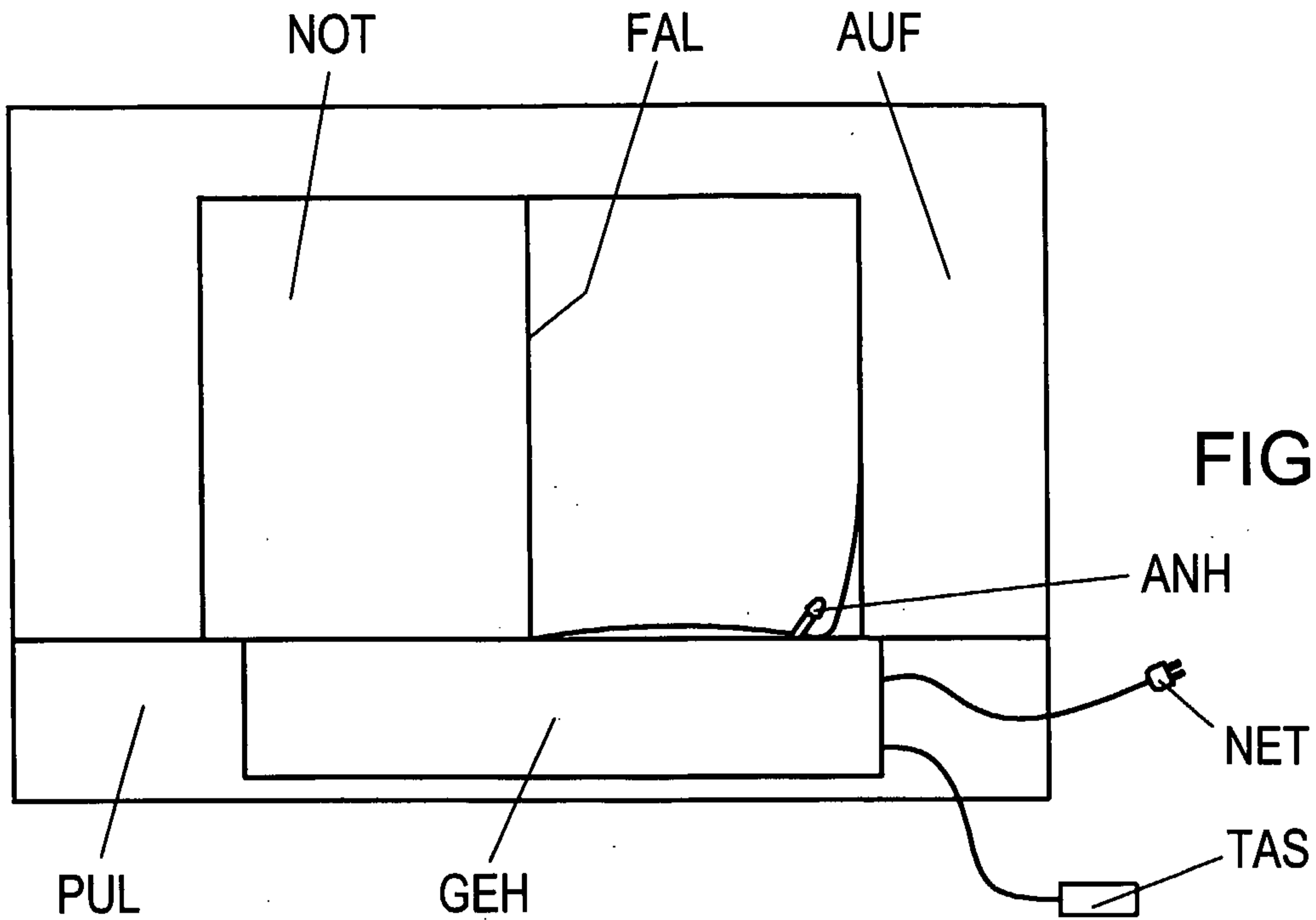

FIG. 1a

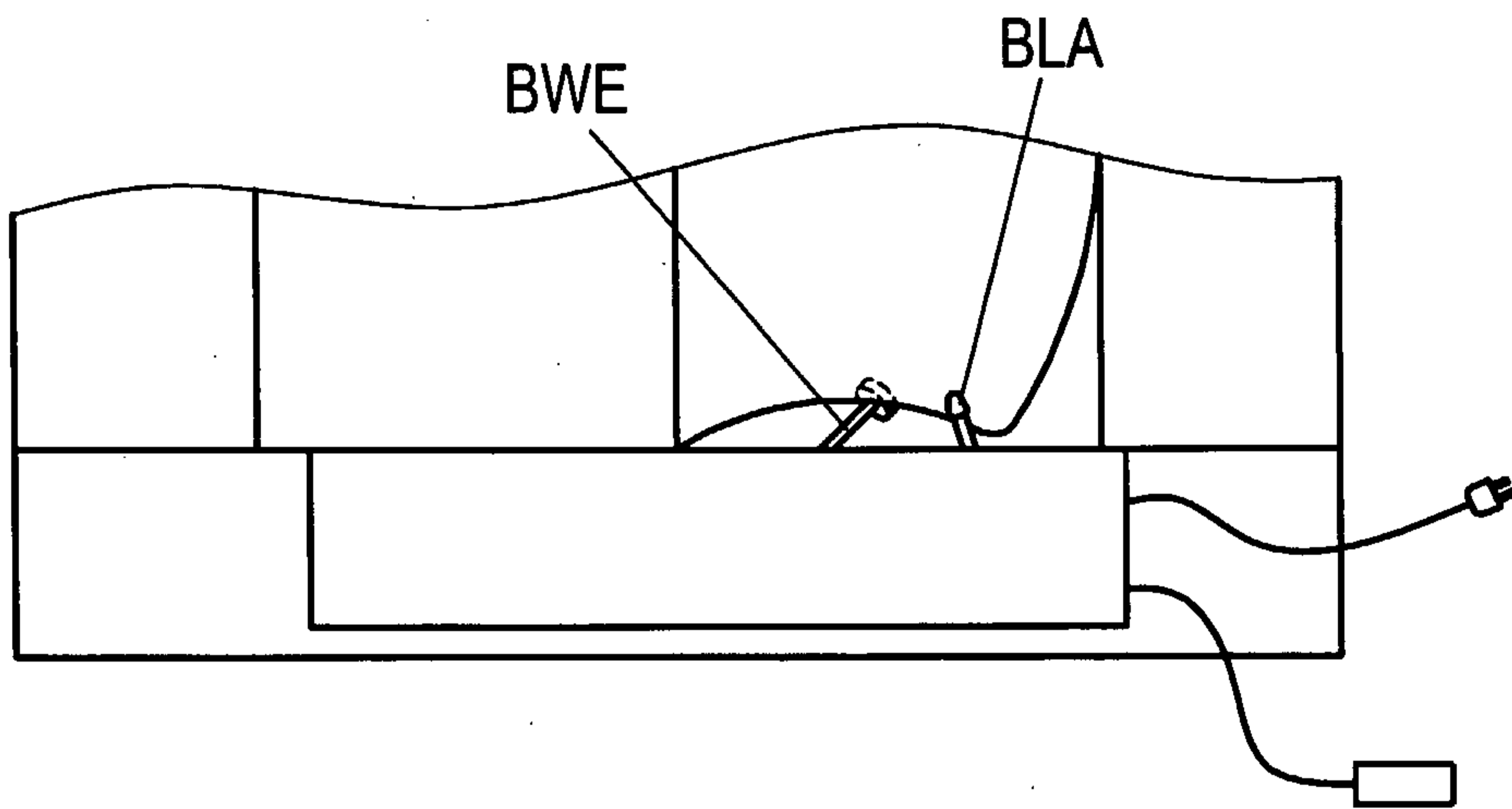

FIG. 1b

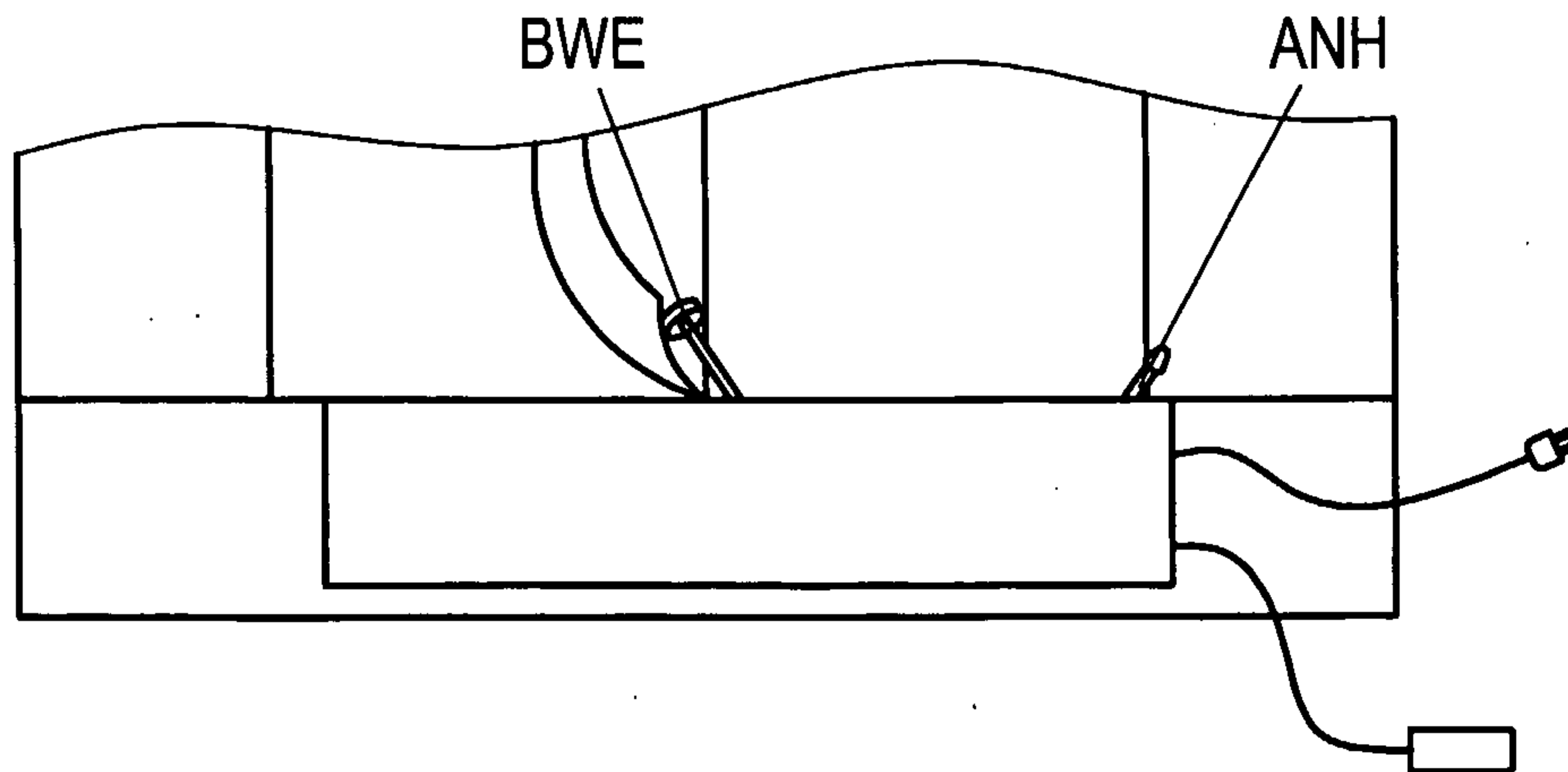

FIG. 1c

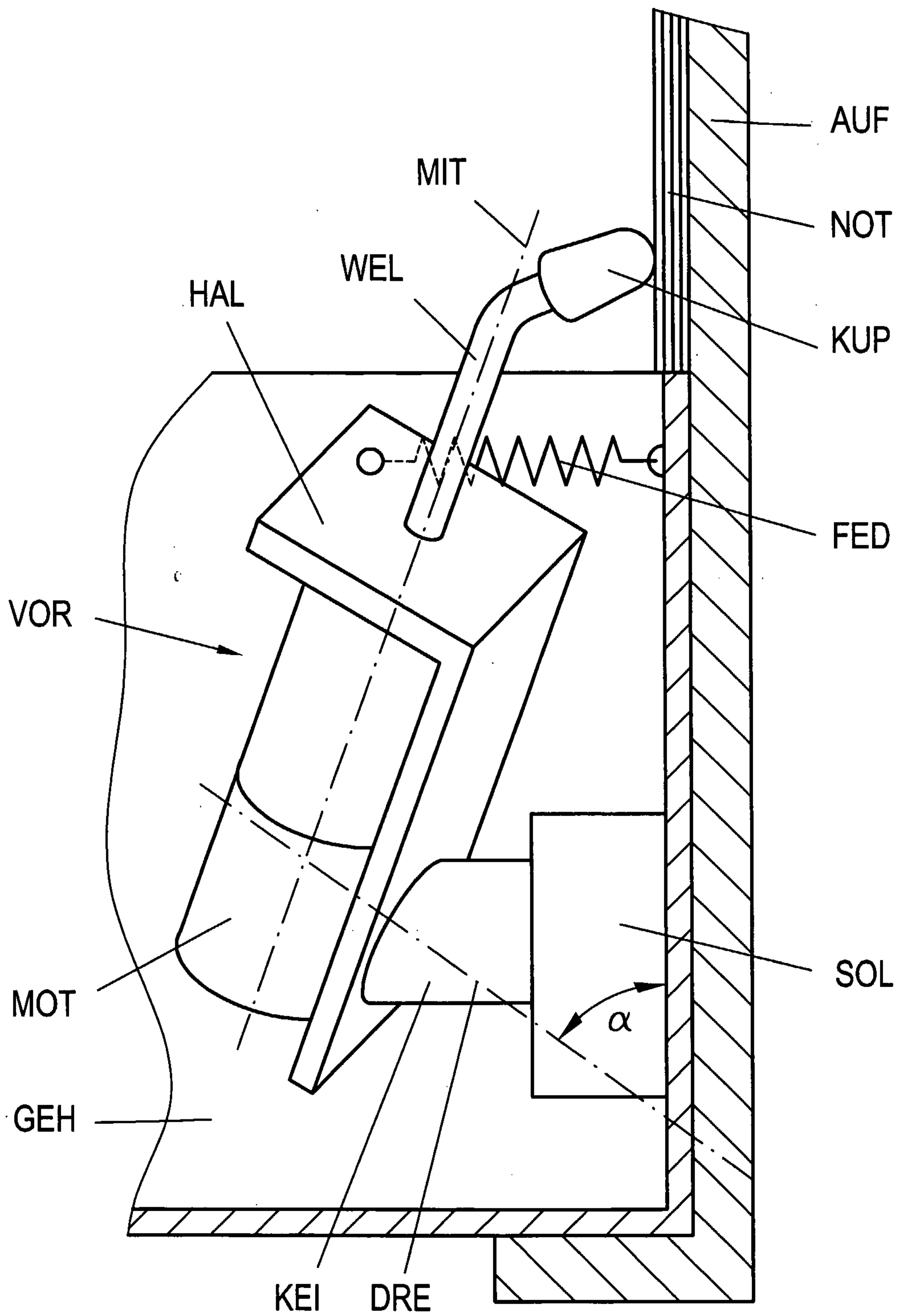

FIG. 2

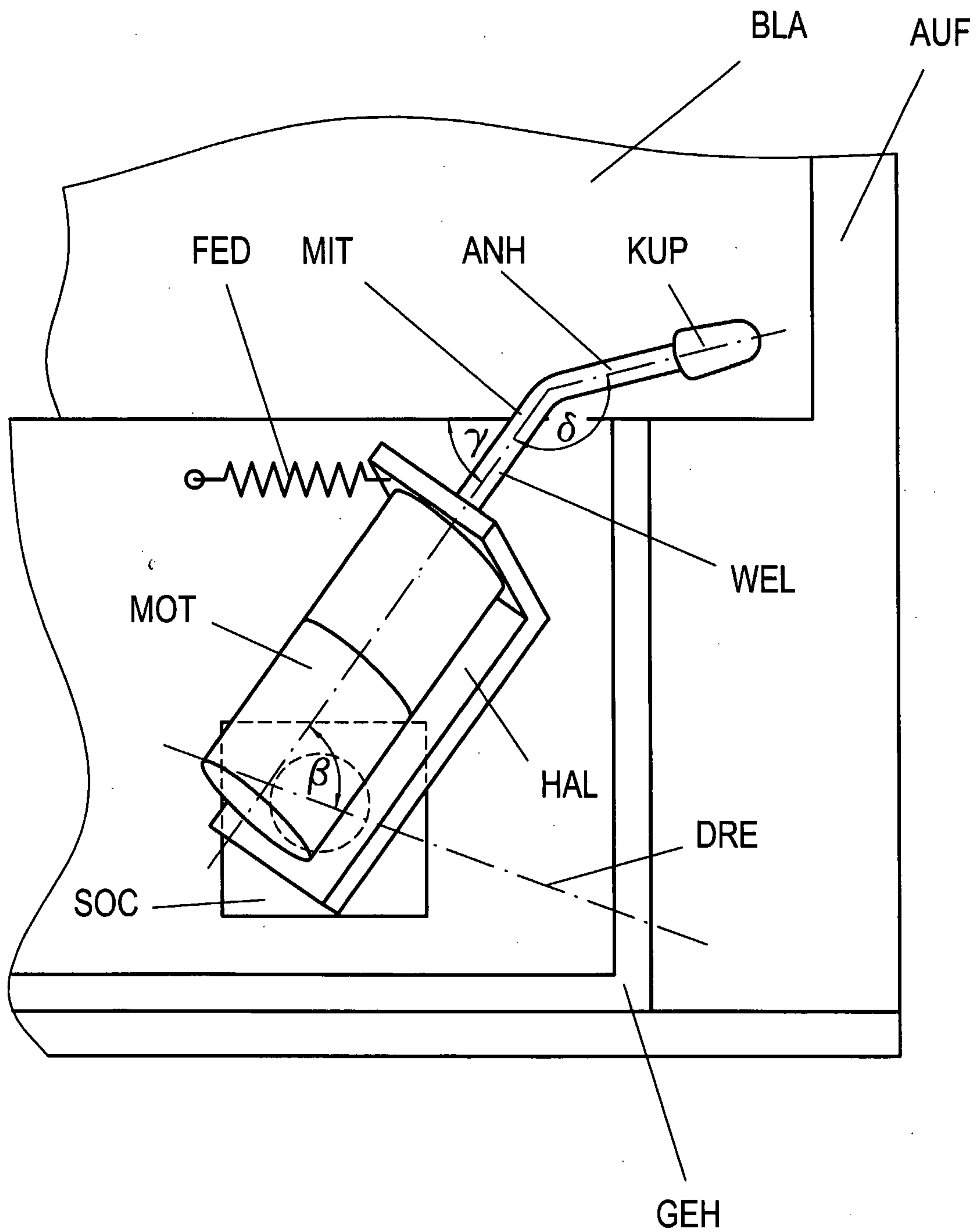

FIG. 3

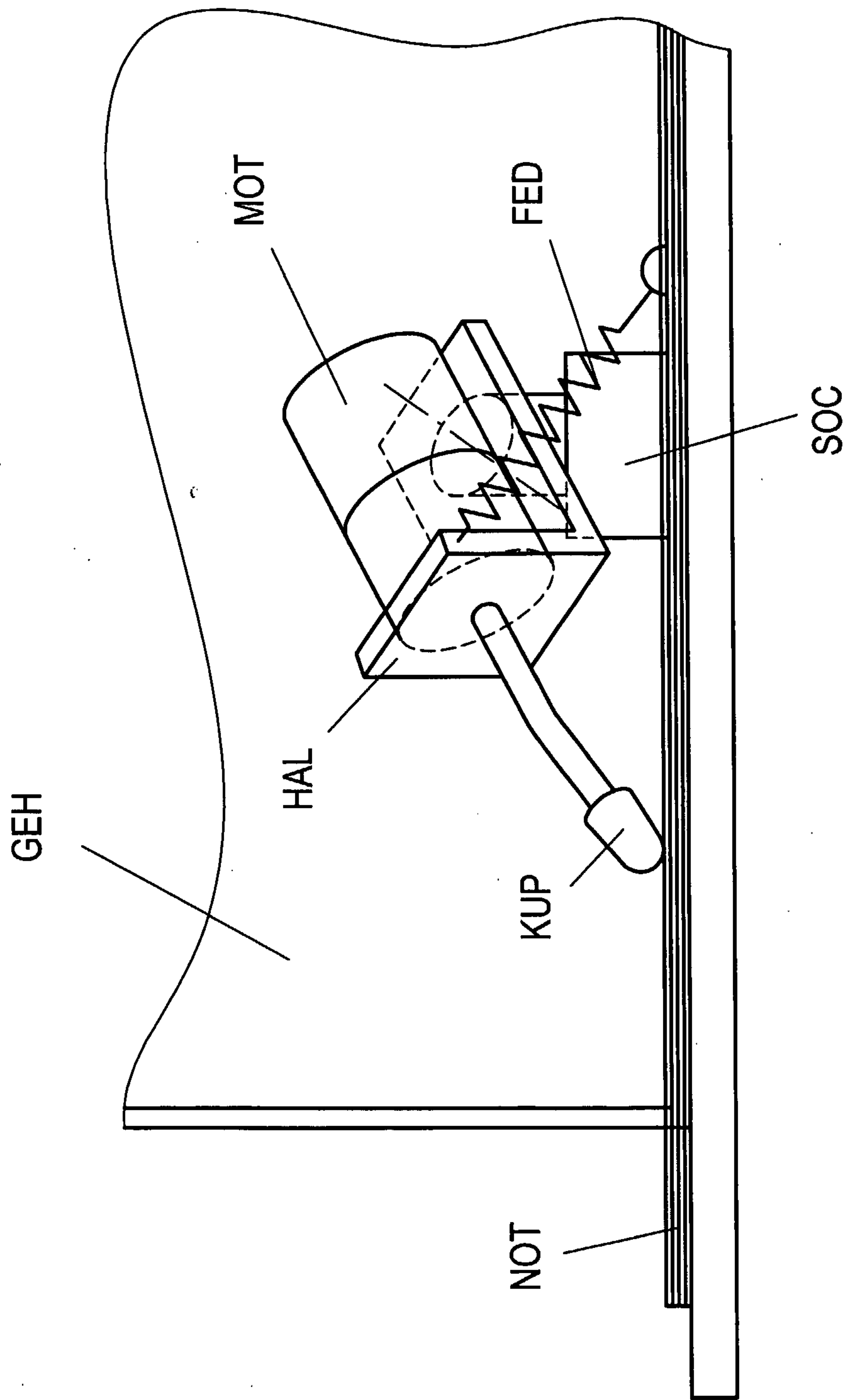

FIG. 4

