



(86) Date de dépôt PCT/PCT Filing Date: 2008/01/18
 (87) Date publication PCT/PCT Publication Date: 2008/07/31
 (85) Entrée phase nationale/National Entry: 2010/07/21
 (86) N° demande PCT/PCT Application No.: GB 2008/000215
 (87) N° publication PCT/PCT Publication No.: 2008/090329
 (30) Priorités/Priorities: 2007/01/23 (GB0701313.9);
 2007/03/22 (GB0705481.0); 2007/08/31 (GB0716832.1)

(51) Cl.Int./Int.Cl. *A63B 21/055* (2006.01),
A41D 13/00 (2006.01)
 (71) Demandeurs/Applicants:
 LEE, MAURICE ANTHONY, UG;
 LEE, LEON PATRICK, GB
 (72) Inventeurs/Inventors:
 LEE, MAURICE ANTHONY, UG;
 LEE, LEON PATRICK, GB
 (74) Agent: DEETH WILLIAMS WALL LLP

(54) Titre : VETEMENT D'EXERCICE
 (54) Title: WORKOUT GARMENT

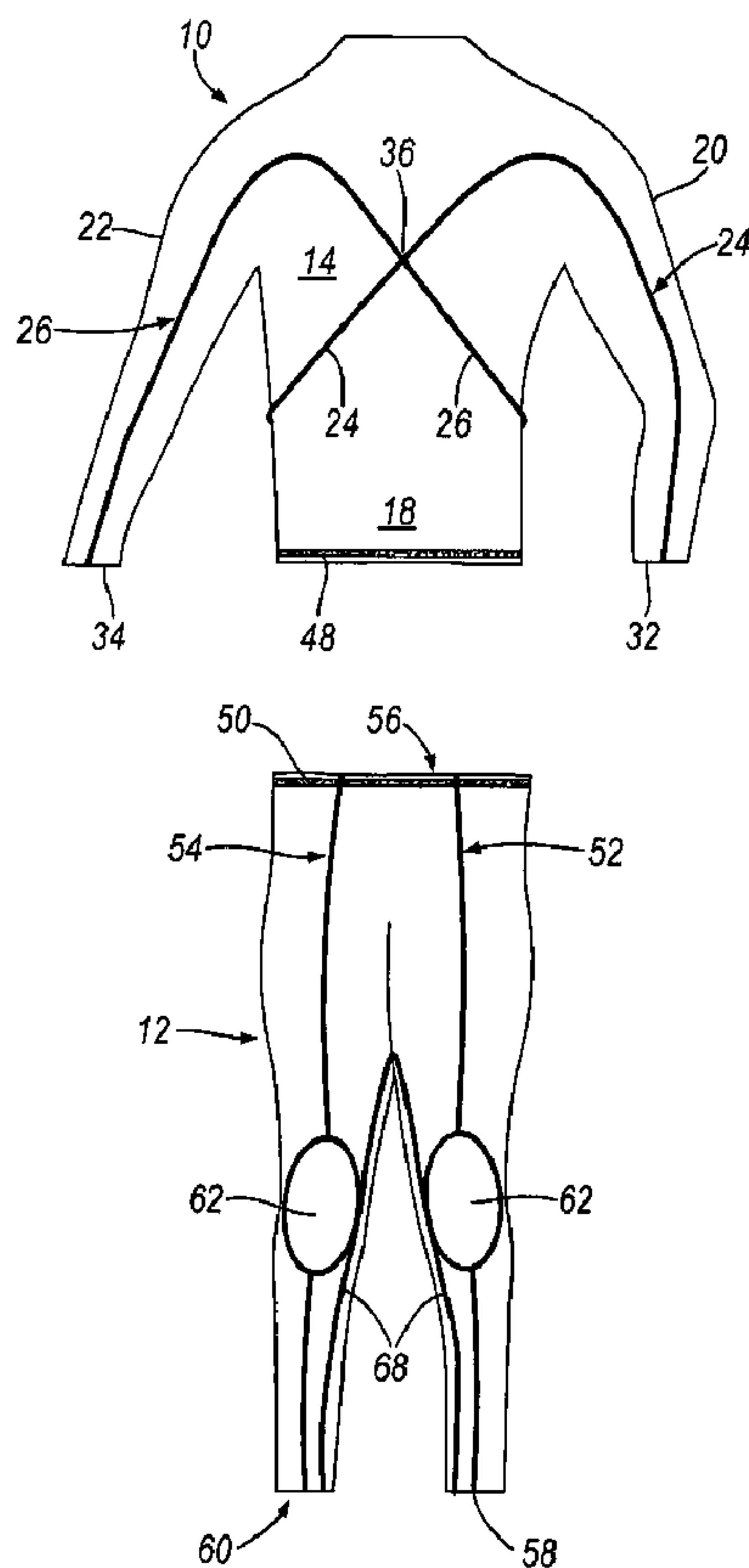

Fig. 1

(57) Abrégé/Abstract:

A workout garment comprises at least a shirt (10; 110) having a chest region (14; 114), a back region (16; 116), and a waist region (18; 118). The garment has a plurality of restrictor bands (24 to 30; 124 to 130) of elastic material extending, in use, over muscles

(57) **Abrégé(suite)/Abstract(continued):**

of the body to be worked, whereby during activity involving movement which stretches said muscles the bands are stretched to provide resistance against said movement. The bands are integrated into the garment and include a two bands (24, 26; 124, 126) which extend continuously across the chest region and cross over in the chest region, and two bands (28, 30; 128, 130) which extend continuously across the back region and cross over in the back region. The crossover (36; 136) in the chest region is positioned higher than the crossover (38; 138) in the back region.

(12) INTERNATIONAL APPLICATION PUBLISHED UNDER THE PATENT COOPERATION TREATY (PCT)

(19) World Intellectual Property Organization
International Bureau(43) International Publication Date
31 July 2008 (31.07.2008)

PCT

(10) International Publication Number
WO 2008/090329 A1

(51) International Patent Classification:

A63B 21/055 (2006.01) A41D 13/00 (2006.01)

(21) International Application Number:

PCT/GB2008/000215

(22) International Filing Date: 18 January 2008 (18.01.2008)

(25) Filing Language:

English

(26) Publication Language:

English

(30) Priority Data:

0701313.9	23 January 2007 (23.01.2007)	GB
0705481.0	22 March 2007 (22.03.2007)	GB
0716832.1	31 August 2007 (31.08.2007)	GB

(71) Applicants and

(72) Inventors: LEE, Maurice, Anthony [GB/GB]; 42 The Pantiles, Bexleyheath, Kent DA7 5HG (GB). LEE, Leon, Patrick [GB/GB]; 42 The Pantiles, Bexleyheath, Kent DA7 5HG (GB).

(74) Agent: GRAHAM WATT & CO LLP; St Botolph's House, 7-9 St Botolph's Road, Sevenoaks, Kent TN13 3AJ (GB).

(81) Designated States (unless otherwise indicated, for every kind of national protection available): AE, AG, AL, AM, AO, AT, AU, AZ, BA, BB, BG, BH, BR, BW, BY, BZ, CA, CH, CN, CO, CR, CU, CZ, DE, DK, DM, DO, DZ, EC, EE, EG, ES, FI, GB, GD, GE, GH, GM, GT, HN, HR, HU, ID, IL, IN, IS, JP, KE, KG, KM, KN, KP, KR, KZ, LA, LC, LK, LR, LS, LT, LU, LY, MA, MD, ME, MG, MK, MN, MW, MX, MY, MZ, NA, NG, NI, NO, NZ, OM, PG, PH, PL, PT, RO, RS, RU, SC, SD, SE, SG, SK, SL, SM, SV, SY, TJ, TM, TN, TR, TT, TZ, UA, UG, US, UZ, VC, VN, ZA, ZM, ZW.

(84) Designated States (unless otherwise indicated, for every kind of regional protection available): ARIPO (BW, GH, GM, KE, LS, MW, MZ, NA, SD, SL, SZ, TZ, UG, ZM, ZW), Eurasian (AM, AZ, BY, KG, KZ, MD, RU, TJ, TM), European (AT, BE, BG, CH, CY, CZ, DE, DK, EE, ES, FI, FR, GB, GR, HR, HU, IE, IS, IT, LT, LU, LV, MC, MT, NL,

[Continued on next page]

(54) Title: WORKOUT GARMENT

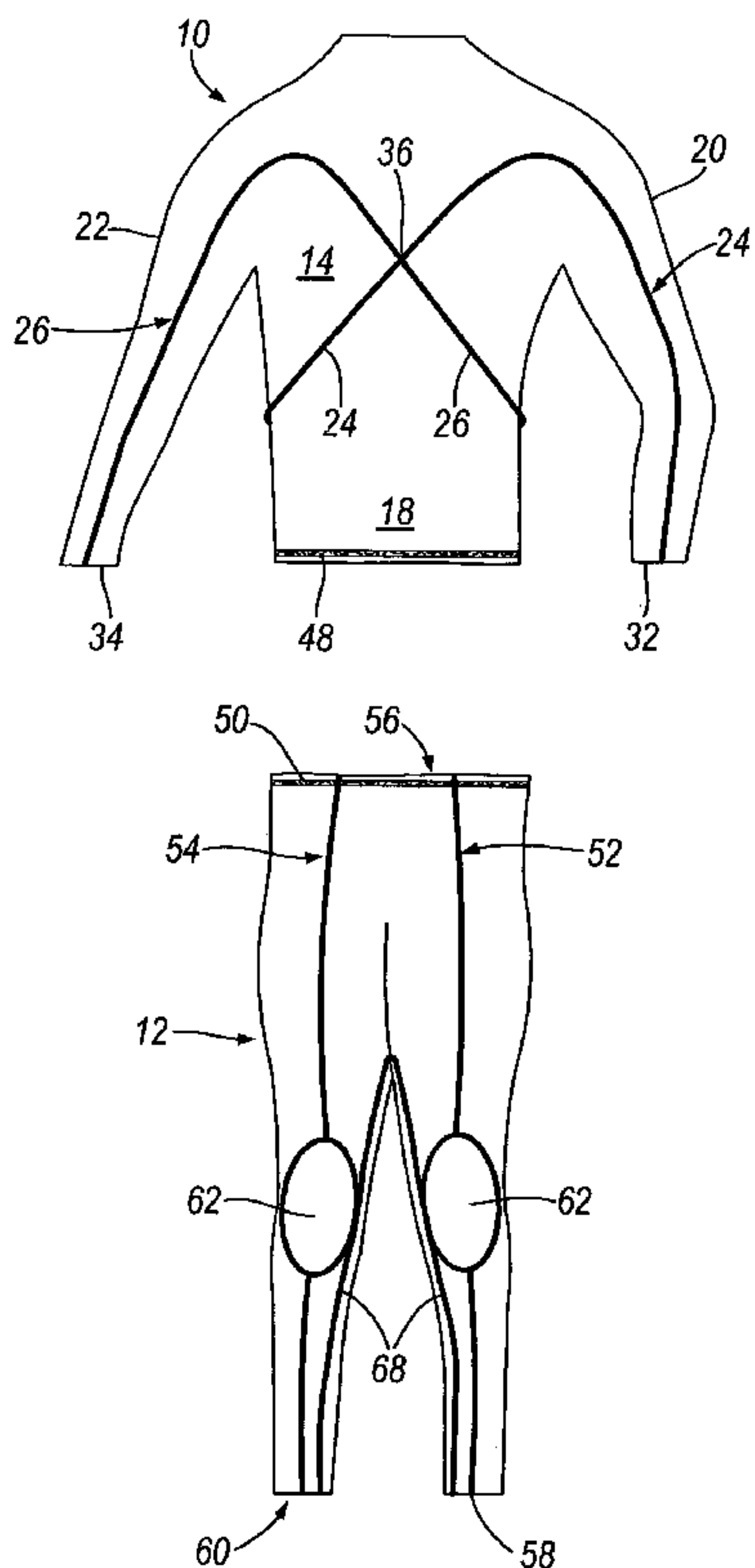

Fig. 1

(57) Abstract: A workout garment comprises at least a shirt (10; 110) having a chest region (14; 114), a back region (16; 116), and a waist region (18; 118). The garment has a plurality of restrictor bands (24 to 30; 124 to 130) of elastic material extending, in use, over muscles of the body to be worked, whereby during activity involving movement which stretches said muscles the bands are stretched to provide resistance against said movement. The bands are integrated into the garment and include a two bands (24, 26; 124, 126) which extend continuously across the chest region and cross over in the chest region, and two bands (28, 30; 128, 130) which extend continuously across the back region and cross over in the back region. The crossover (36; 136) in the chest region is positioned higher than the crossover (38; 138) in the back region.

WO 2008/090329 A1

WO 2008/090329 A1



NO, PL, PT, RO, SE, SI, SK, TR), OAPI (BF, BJ, CF, CG, CI, CM, GA, GN, GQ, GW, ML, MR, NE, SN, TD, TG). **Published:** — *with international search report*

WORKOUT GARMENT

Field of the invention

5 The present invention relates to a workout garment, particularly to a garment which helps to train the muscles of the user.

Background of the invention

10 Human beings are genetically predisposed with a larger proportion of one type of muscle group over another. An individual born with a greater proportion of Type I slow muscle fibres would theoretically be more suited to endurance events, while a greater proportion of Type II fast muscle fibres, would be more likely to excel at high impact events.

15 A number of workout or exercise garments are known. The known garments may be in the form of suits or separate shirts and pants.

20 For example in United States patent US 5 720 042 (Wilkinson) there is described an energy expenditure garment which includes a body portion and a pair of limb portions, such as arms or legs. At least one section of the garment is made of closed loop circumferential form to completely surround a portion of the user and is made of elastic resilient material thereby applying a compressive force to that portion of the user. The garment also includes a plurality of elongated elements made of elastic resilient material located on the garment and anchored across areas of the garment which would be subjected to back and forth movement
25 during the performance of an activity by the user. The elongate resistive elements can be incorporated in the garment.

30 Other known examples include those described in United States patents US 4 065 814 (Fox), US 5 819 322 (Wilkinson), US 5 867 827 (Wilkinson), US 5 606 745 (Gray) and US 5 308 305 (Romney).

35 US 4 065 814 (Fox) describes a one piece elastic body suit worn by a person to coordinate and tone the body includes an outer and an inner layer joined together, wherein each layer has a shirt and trouser section. A plurality of elastic band members are disposed between the inner and outer layers of the suit. This

suit is found to be too heavy while the inner layer causes increased perspiration.

US 5 819 322 (Wilkinson) describes energy conservation or expenditure garments which are designed for use by cyclists. The garment includes in one
5 embodiment an air cooling system through use of various air passageways in the energy conservation garment. In another embodiment the energy expenditure garment includes pockets to offer drag or resistance to the user. An indicator may be provided at the back of the hand portion of the garment to indicate some
10 parameter of exercise.

US 5 867 827 (Wilkinson) describes an energy expenditure garment is in the form of a one piece suit having a neck opening at its top and leg openings at the bottom of its torso section. Size adjusting structure is provided at the neck opening to permit the neck opening to be enlarged from its first wearing size to an
15 enlarged passage size sufficiently large so that the garment may be placed on the user by the user inserting the user's legs, hips and body through the enlarged neck opening.

US 5 606 745 (Gray) describes a resistance exercise suit for providing a
20 resistance to movement to exercise the wearer's muscles. The resistance exercise suit includes a body suit to which at least one resilient rib is secured for biasing a selected body portion in a preselected position such that when the wearer moves the body portion, he experiences resistance. The resilient rib is tailorable to a particular individual's needs, and specifically, the shape, length,
25 thickness and resistance are alterable properties.

US 5 308 305 (Romney) describes an apparatus for augmenting exercise of body muscle(s) comprising one or more articles of close-fitting wearing apparel employing one or more removable elongate resistance members, loosely
30 enclosed in passageways along a portion of the length of the apparel, which resistance members releasably anchored at one end to a fixed-in-place member such as a belt or a shoulder harness and attached at the distal end to the extremity of an arm or leg, the apparatus being devised so as to increase the energy required by a user to flex his arms or legs over the energy level necessary
35 without the resistance of the elongate resistance members. The elongate

resistance members are fixed to the surface of the garment and can therefore become entangled, hazardous and uncomfortable.

We are also aware of United States patent US 3411500 (Gatts) which describes an article of wear for applying a stress on the wearer, to simulate gravitational mass loadings on the body. Also, United States patent US 5857947 (Dicker et al.) describes an energy expenditure garment which includes various elastic resistance elements located on the garment so as to help in the training of a user while participating in a swinging sport, such as golf or racquet sports. The garment could also include a biofeedback sensor to indicate when a proper swing has or has not been performed.

The known garments have suffered from being of complicated construction, are too heavy or cannot easily be used, or do not exercise all the major muscle groups, and may thus result in an imbalance of muscle growth.

SUMMARY OF THE INVENTION

According to the invention there is provided a workout garment comprising at least a shirt having a chest region, a back region, and a waist region, and having a plurality of restrictor bands of elastic material extending, in use, over muscles of the body to be worked, whereby during activity involving movement which stretches said muscles the bands are stretched to provide resistance against said movement, the bands being integrated into the garment and comprising two bands which extend continuously across the chest region and cross over in the chest region, and two bands which extend continuously across the back region and cross over in the back region, characterized in that the crossover in the chest region is positioned higher than the crossover in the back region.

The workout garments according to the invention represent a convenient way to maximise training, in minimum time, working the major muscles and giving a balanced workout that can be used in several workout environments. By avoiding the use of weights, the garments can be constructed to be light weight and comfortable, sporty and aerobic, uncomplicated and easy to put on and use while

remaining in the correct position. The workout garments according to the invention are designed to give resistance to all major muscles of the body without the need to set individual resistance for the muscles.

5 The workout garments according to the invention develop both Type I and Type II muscle groups in proportion. These advantages stem from the specific positioning of the restrictor bands, which are placed directly over major muscles so that when the restrictor bands are stretched the opposing muscle is worked harder. This causes conditioned resistance when involved in activity.

10 Preferably each of the chest bands is joined respectively to one or the other of the back bands in the waist region. The bands may be joined to each other in the waist region at a location behind a nominal dividing line between the chest and back regions.

15 Each band may be secured to the garment by means of stitching and/or adhesive, for example by means of cross-stitching using elastic thread and/or using an adhesive which in the dry state is stretchable.

20 Preferably, the bands are secured to each other at the crossovers.

The elasticity of the material from which the garment is formed is ideally greater than the elasticity of the restrictor bands. The garment may be formed of a compressive material such as Lycra™, having a thickness of no more than 2 mm.

25 The restrictor bands may be formed of latex rubber and are ideally thicker than the material of which the garment may be formed, having a thickness of no more than 2.5 mm.

30 Preferably, the restrictor bands have a width of between 1.0 cm and 5.0 cm, such as about 2.5 cm.

In one embodiment of the invention, the shirt preferably includes left and right sleeves and the bands comprise:

35 a first chest band which extends continuously from the wrist opening

- 5 -

of the left sleeve along the left sleeve and across the chest region to the waist region on the right side of the shirt, and a second chest band which extends continuously from the wrist opening of the right sleeve along the right sleeve and across the chest region to the waist region on the left side of the shirt, so that the first and second chest bands form the crossover in the chest region; and

a first back band which extends continuously from the wrist opening of the left sleeve along the left sleeve and across the back region to the waist region on the right side of the shirt, and a second back band which extends continuously from the wrist opening of the right sleeve along the right sleeve and across the back region to the waist region on the left side of the shirt, so that the first and second back bands form the crossover in the back region.

In such an embodiment, the back bands preferably extend around the elbow joints to allow for movement thereof.

In an alternative embodiment, the workout garment according to the invention is in the form of a workout suit additionally comprising pants, wherein further restrictor bands extend continuously at least from the waist region of the suit to ankle openings of the pants. In such an embodiment, in the pants the bands preferably extend around the knee joints to allow for movement of the knee joints.

The pants may be integral or non-integral with the shirt.

When the pants are integral with the shirt, the further restrictor bands may extend continuously from wrist openings of the suit to ankle openings of the pants. For example, one band extends continuously from the left wrist opening to the right ankle opening, while another band extends continuously from the right wrist opening to the left ankle opening.

Where the workout garment according to the invention is in the form of a workout suit having pants non-integral with the shirt, hook and loop type fastenings, such as Velcro™, may be provided between the pants and the shirt.

The invention will now be further described, purely by way of example, with reference to the accompanying drawings, in which:

- 6 -

Figure 1 shows a front view of a workout suit incorporating a workout garment according to a first embodiment of the invention;

Figure 2 shows a rear view of the workout suit shown in Figure 1;

5

Figure 3 shows a right hand side view of the shirt of the workout suit shown in Figure 1, with the sleeve being shown in dotted lines for the sake of clarity;

10

Figure 4 shows a front view of a workout suit incorporating a workout garment according to a second embodiment of the invention; and

Figure 5 shows a rear view of the workout suit shown in Figure 4.

15

Figures 1 and 2 show a figure hugging workout garment in the form of shirt 10 and separate pants 12, both formed of Lycra™ with a thickness of about 1.0 mm. The shirt 10 has a chest region 14, a back region 16, a waist region 18 and left and right sleeves 20, 22.

20

Four restrictor bands 24, 26, 28, 30 formed of latex rubber are integrated into the shirt 10. The first chest band 24 extends continuously from the wrist opening 32 of the left sleeve 20 along the left sleeve 20 and across the chest region 14 to the waist region 18 on the right side of the shirt 10. The second chest band 26 extends continuously from the wrist opening 34 of the right sleeve 22 along the right sleeve 22 and across the chest region 14 to the waist region 18 on the left side of the shirt 10, so that the first and second chest bands form a crossover 36 in the chest region 14, just over the sternum of the user.

25

30

The first back band 28 extends continuously from the wrist opening 32 of the left sleeve 20 along the left sleeve 20 and across the back region 16 to the waist region 18 on the right side of the shirt 10. The second back band 30 extends continuously from the wrist opening 34 of the right sleeve 22 along the right sleeve 22 and across the back region 16 to the waist region 18 on the left side of the shirt 10, so that the first and second back bands form a crossover 42 in the back region 16, under the shoulder blades of the user but above the waist.

35

The crossover 36 in the chest region 14 is positioned higher than the crossover 42 in the back region 16. The back bands 28, 30 extend around the elbow joints 40, 42 to allow for movement thereof.

5 The restrictor bands have a width of about 2.5 cm and a thickness of 1.5 mm. Each restrictor band 24 to 30 is secured to the garment by means of cross-stitching using elastic thread and stretchable adhesive. The bands are also secured to each other by cross-stitching with elastic thread at the crossovers 36, 38.

10 As shown in Figure 3, each of the chest bands 24, 26 is joined respectively to one or the other of the back bands 28, 30 in the waist region 18 at a location 44 behind a nominal dividing line 38 between the chest and back regions 14, 16.

15 The restrictor bands extend over muscles of the body to be worked. The elasticity of the material from which the garment is formed is greater than the elasticity of the restrictor bands and the restrictor bands are thicker than the material of which the garment is formed, so that during activity involving movement which stretches said muscles the bands are stretched to provide resistance against said
20 movement. When wearing the suit the body is under resistance when moving, whether it be physical activity or every day activity.

The workout garment is in the form of a workout suit having separate figure hugging pants 12, with Velcro™ fastenings 48, 50 between the pants 12 and the
25 shirt 10.

Further restrictor bands 52, 54 extend continuously at least from the waist region 56 of the pants down the front of each leg of the pants to ankle openings 58, 60 of the pants 12. The bands 52, 54 extend around the knee joints 62 to allow for
30 movement of the knee joints.

Further restrictor bands 64, 66 extend continuously at least from the waist region 56 of the pants down the back of each leg of the pants to ankle openings 58, 60.

35 Still further restrictor bands 68 extend from the top of the inside of both legs to the

inside of both ankle openings 58, 60.

The further bands 52, 54, 64, 66 and 68 are secured to the pants 12 in the same manner as the bands 24 to 30 are secured to the shirt 10.

5

Figures 4 and 5 show a figure hugging workout suit in the form of shirt part 110 and integral pants part 112, both formed of Lycra™ with a thickness of about ... mm. The shirt part 110 has a chest region 114, a back region 116, a waist region 118 and left and right sleeves 120, 122. The suit has a closure (not shown) at the back which permits the wearer to put the suit on and remove it, Velcro™ or a zip fastener being used as a closure material.

10

15

Four restrictor bands 124, 126, 128, 130 formed of latex rubber are integrated into the shirt part 110. The first chest band 124 extends continuously from the wrist opening 132 of the left sleeve 120 along the left sleeve 120 and across the chest region 114 to the waist region 118 on the right side of the shirt part 110. The second chest band 126 extends continuously from the wrist opening 134 of the right sleeve 122 along the right sleeve 122 and across the chest region 114 to the waist region 118 on the left side of the shirt part 110, so that the first and second chest bands form a crossover 136 in the chest region 114, just over the sternum of the user.

20

25

The first back band 128 extends continuously from the wrist opening 132 of the left sleeve 120 along the left sleeve 120 and across the back region 116 to the waist region 118 on the right side of the shirt part 110. The second back band 130 extends continuously from the wrist opening 134 of the right sleeve 122 along the right sleeve 122 and across the back region 116 to the waist region 118 on the left side of the shirt part 110, so that the first and second back bands form a crossover 138 in the back region 116, just under the shoulder blades of the user.

30

The crossover 136 in the chest region 114 is positioned higher than the crossover 138 in the back region 116. The back bands 128, 130 extend around the elbow joints 140, 142 to allow for movement thereof.

35

The restrictor bands have a width of about 2.5 cm and a thickness of 1.5 mm.

Each restrictor band 124 to 130 is secured to the suit by means of cross-stitching using elastic thread and stretchable adhesive. The bands are also secured to each other by cross-stitching with elastic thread at the crossovers 136, 138.

5 Each of the chest bands 124, 126 is joined respectively to one or the other of the back bands 128, 130 in the waist region 118 at a location behind a nominal dividing line between the chest and back regions 114, 116, in a manner similar to that shown in connection with the embodiment shown in Figures 1 to 3.

10 The restrictor bands extend over muscles of the body to be worked. The elasticity of the material from which the suit is formed is greater than the elasticity of the restrictor bands and the restrictor bands are thicker than the material of which the suit is formed, so that during activity involving movement which stretches said muscles the bands are stretched to provide resistance against said movement.

15 Further restrictor bands 152, 154 extend continuously at least from the waist region 118 of the pants part down the front of each leg of the pants part to ankle openings 158, 160. The bands 152, 154 extend around the knee joints 162 to allow for movement of the knee joints.

20 Further restrictor bands 164, 166 extend continuously at least from the waist region 118 of the pants part down the back of each leg of the pants part to ankle openings 158, 160 of the pants part 112.

25 Still further restrictor bands 168 extend from the top of the inside of both legs to the inside of both ankle openings 158, 160.

The further bands 152, 154, 164, 166 and 168 are secured to the pants part 112 in the same manner as the bands 124 to 130 are secured to the shirt part 110.

- 10 -

CLAIMS

1. A workout garment comprising at least a shirt having a chest region, a back region, and a waist region, and having a plurality of restrictor bands of elastic material extending, in use, over muscles of the body to be worked, whereby during activity involving movement which stretches said muscles the bands are stretched to provide resistance against said movement, the bands being integrated into the garment and comprising two bands which extend continuously across the chest region and cross over in the chest region, and two bands which extend continuously across the back region and cross over in the back region, characterized in that the crossover in the chest region is positioned higher than the crossover in the back region.
2. A workout garment according to claim 1, wherein each of the chest bands is joined respectively to one or the other of the back bands in the waist region.
3. A workout garment according to claim 2, wherein the bands are joined to each other in the waist region at a location behind a nominal dividing line between the chest and back regions.
4. A workout garment according to any preceding claim, wherein each band is secured to the garment by means of stitching and/or adhesive.
5. A workout garment according to claim 4, wherein each band is secured to the garment by means of cross-stitching.
6. A workout garment according to claim 4 or 5, wherein each band is secured to the garment by means of stitching using elastic thread.
7. A workout garment according to claim 4, wherein the adhesive is stretchable.
8. A workout garment according to any preceding claim, wherein the bands are secured to each other at the crossovers.

9. A workout garment according to any preceding claim, wherein the elasticity of the material from which the garment is formed is greater than the elasticity of the restrictor bands.

5 10. A workout garment according to any preceding claim, wherein the bands are thicker than the material of which the garment is formed.

11. A workout garment according to any preceding claim, wherein the restrictor bands have a width of between 1.0 cm and 5.0 cm.

10

12. A workout garment according to any preceding claim, wherein the garment is formed of a compressive material.

15

13. A workout garment according to any preceding claim, wherein the shirt includes left and right sleeves and the bands comprise:

a first chest band which extends continuously from the wrist opening of the left sleeve along the left sleeve and across the chest region to the waist region on the right side of the shirt, and a second chest band which extends continuously from the wrist opening of the right sleeve along the right sleeve and across the chest region to the waist region on the left side of the shirt, so that the first and second chest bands form the crossover in the chest region; and

20

a first back band which extends continuously from the wrist opening of the left sleeve along the left sleeve and across the back region to the waist region on the right side of the shirt, and a second back band which extends continuously from the wrist opening of the right sleeve along the right sleeve and across the back region to the waist region on the left side of the shirt, so that the first and second back bands form the crossover in the back region.

25

14. A workout garment according to claim 13 wherein the back bands extend around the elbow joints to allow for movement thereof.

30

15. A workout garment according to any preceding claim, in the form of a workout suit additionally comprising pants, wherein further restrictor bands extend continuously at least from the waist region of the suit to ankle openings of the pants.

35

- 12 -

16. A workout garment according to claim 15 wherein, in the pants the bands extend around the knee joints to allow for movement of the knee joints.

5 17. A workout garment according to claim 15 or 16, wherein the pants are integral with the shirt.

10 18. A workout garment according to claim 17, wherein said further restrictor bands extend continuously from wrist openings of the suit to ankle openings of the suit.

15 19. A workout garment according to claim 18, wherein one band extends continuously from the left wrist opening to the right ankle opening, while another band extends continuously from the right wrist opening to the left ankle opening.

20 20. A workout garment according to claim 15 or 16, in the form of a workout suit having pants non-integral with the shirt, with hook and loop type fastenings between the pants and the shirt.

1/4

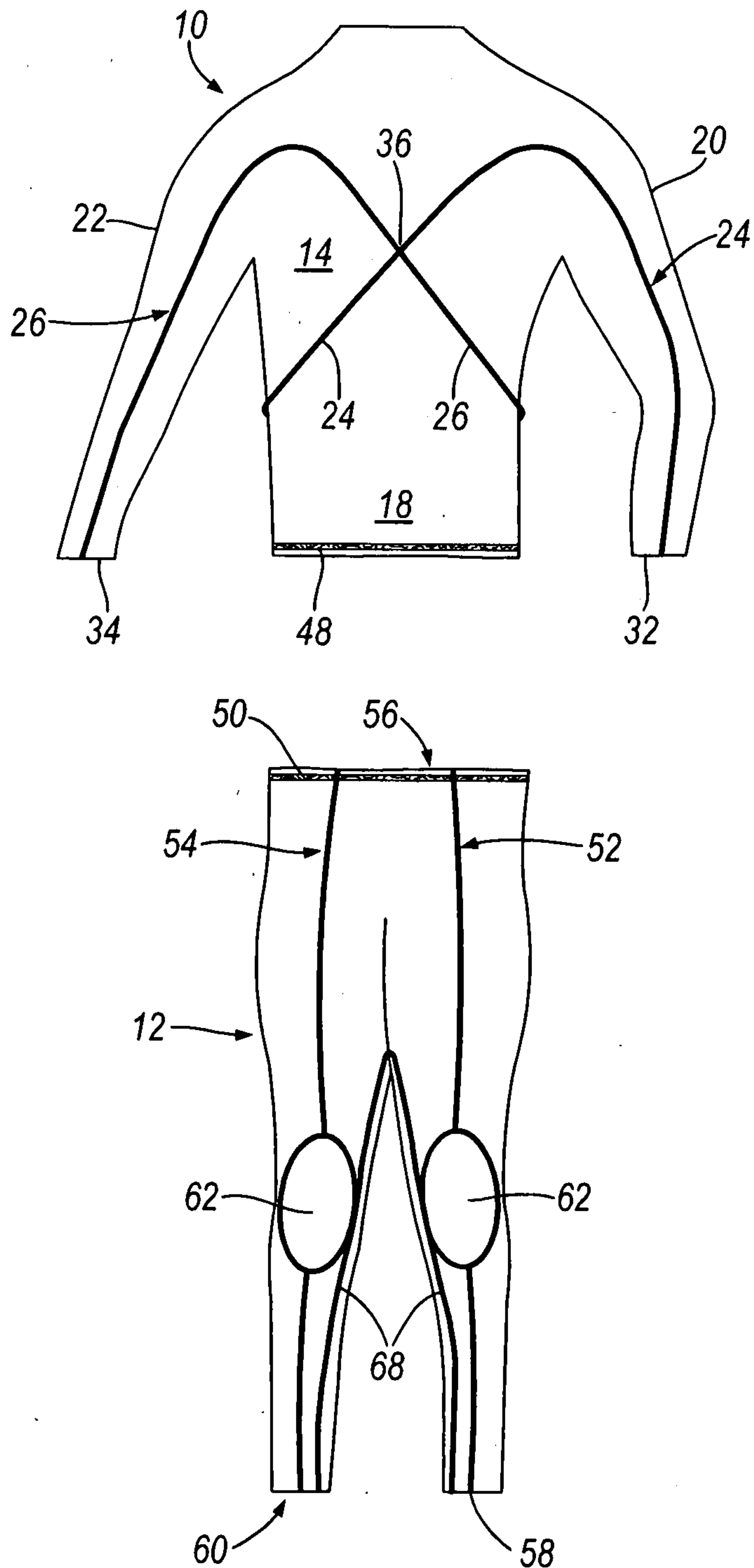

Fig. 1

2/4

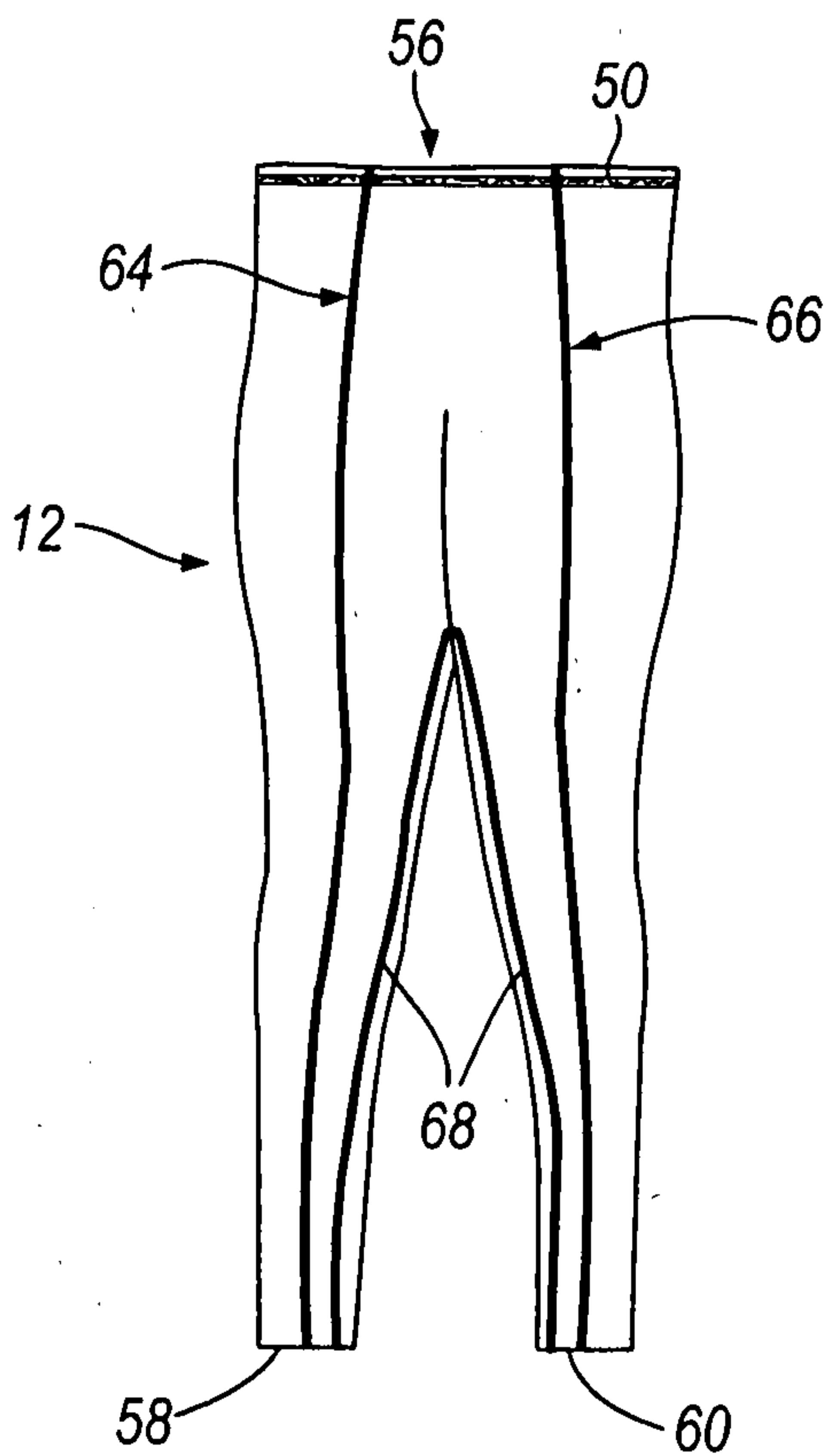
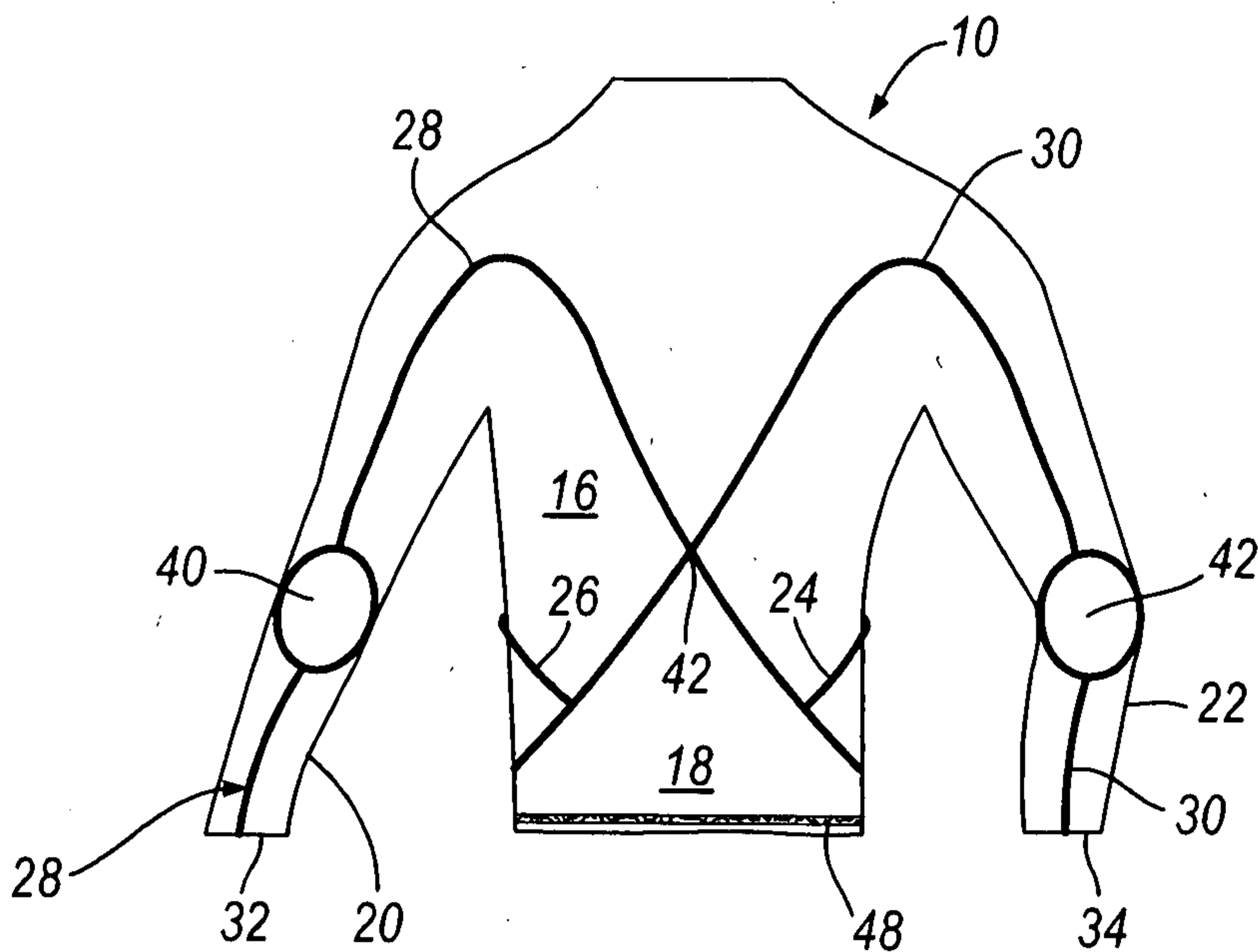

Fig. 2

3/4

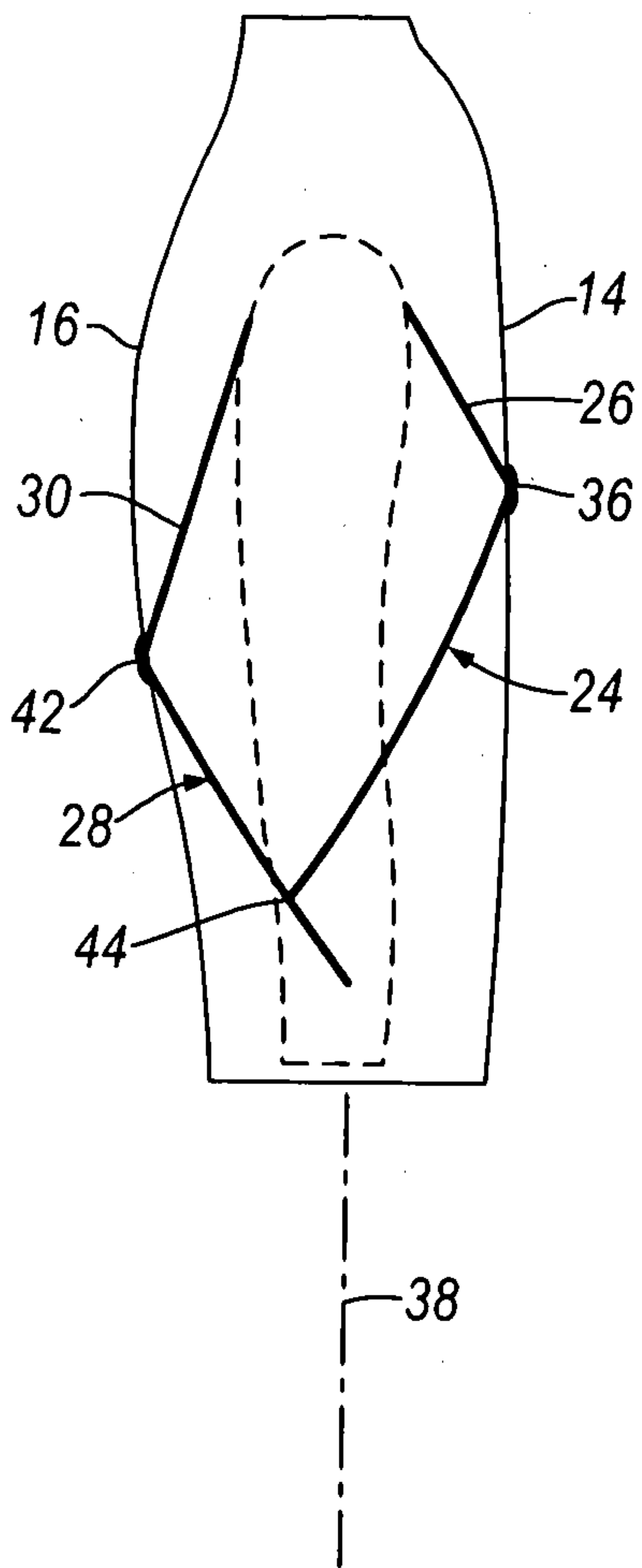

Fig. 3

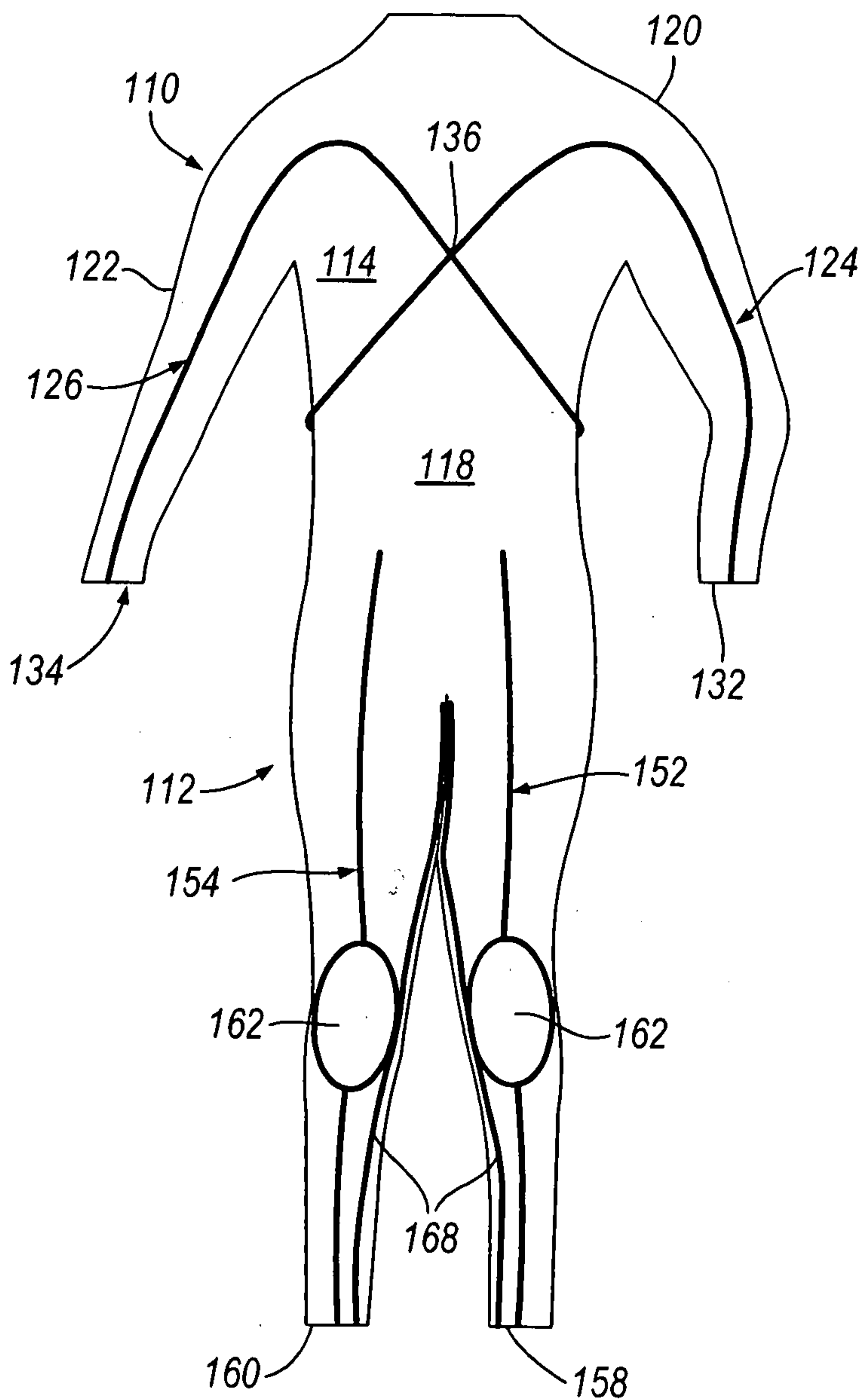

Fig. 4

4/4

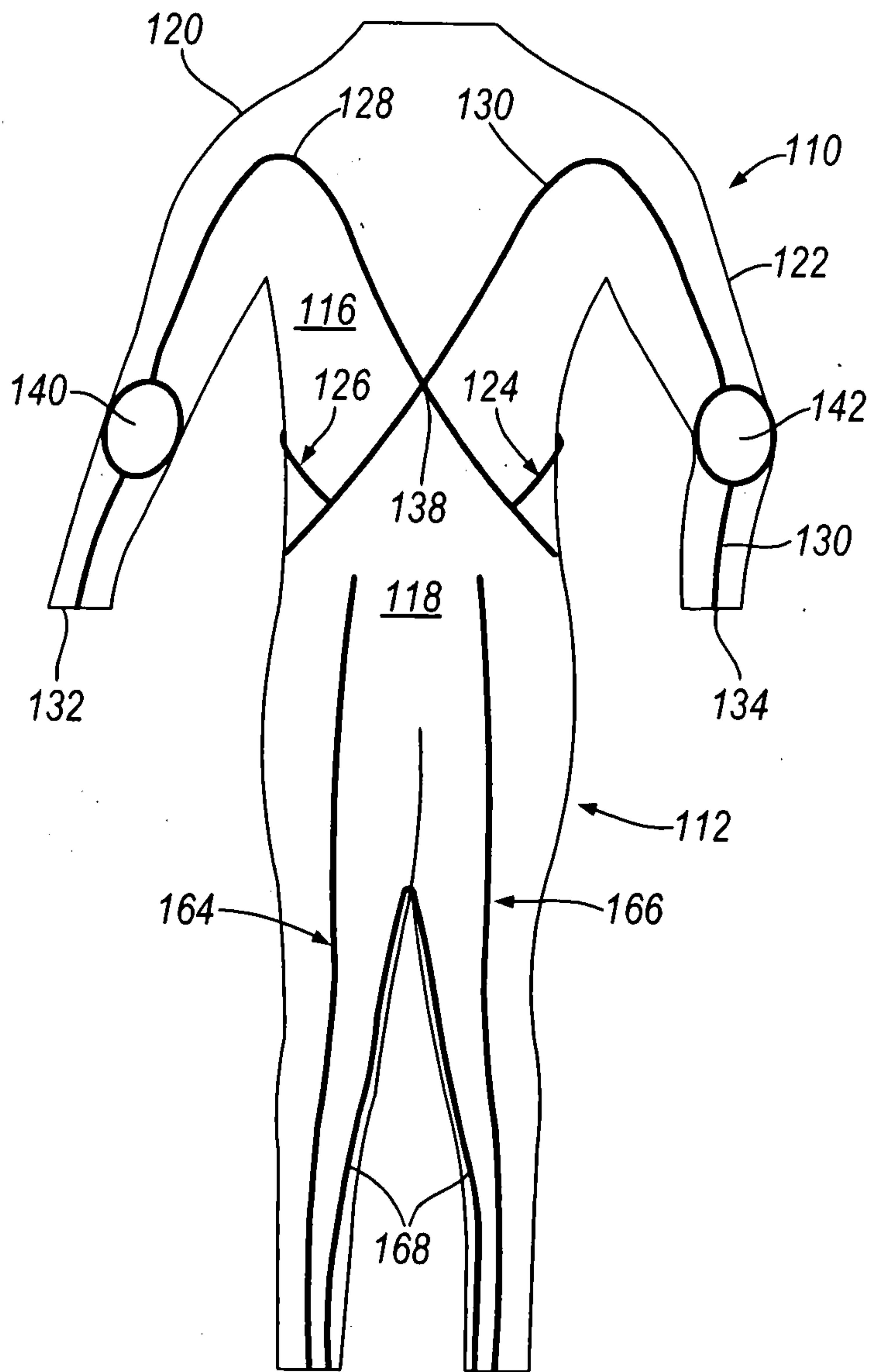

Fig.5

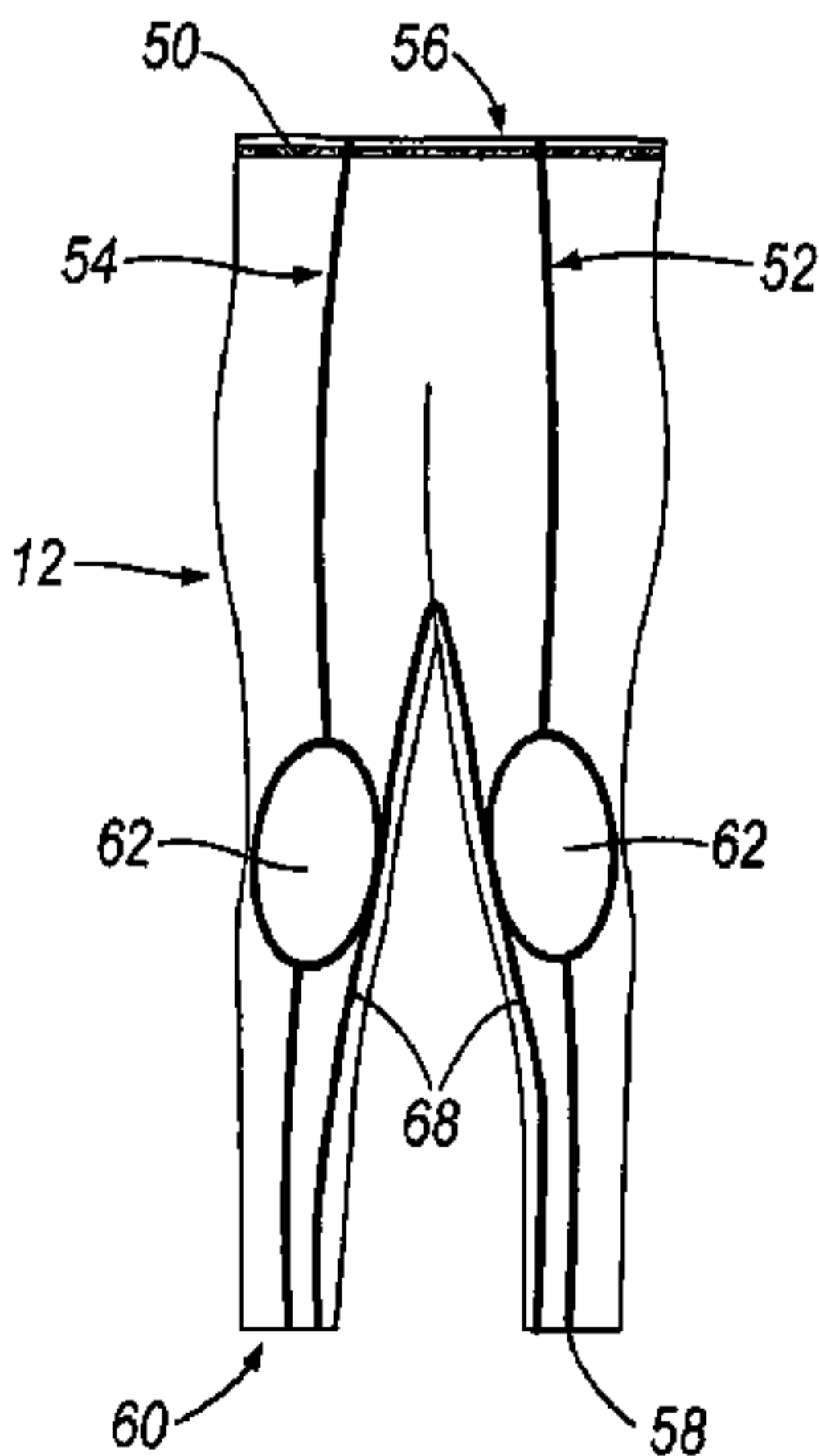
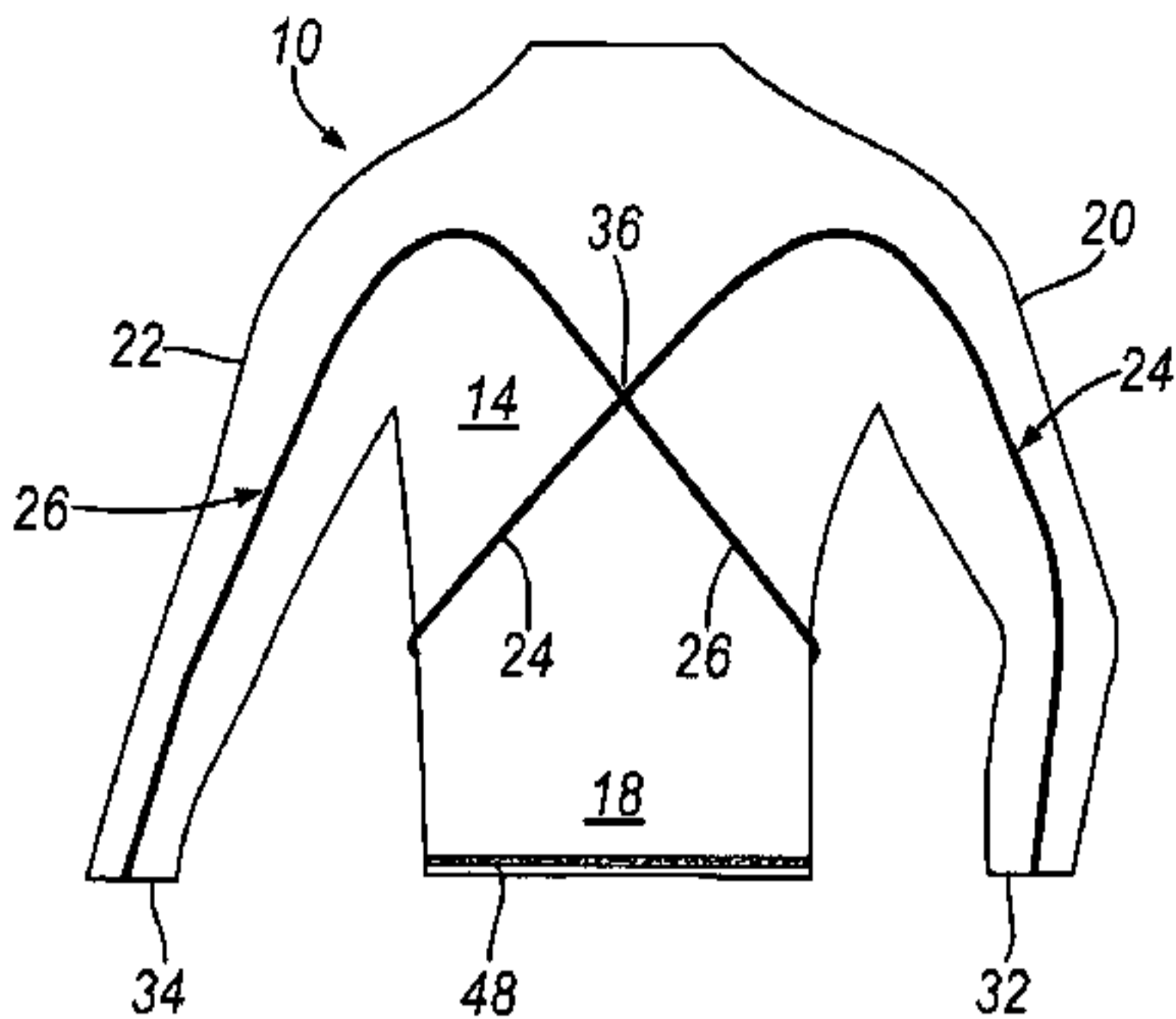

Fig. 1