



US 20060283751A1

(19) **United States**

(12) **Patent Application Publication**
Rhea

(10) **Pub. No.: US 2006/0283751 A1**

(43) **Pub. Date: Dec. 21, 2006**

(54) **FEMININE PRODUCT DISPOSAL ENVELOPE WITH CLEANSING WIPES**

Related U.S. Application Data

(60) Provisional application No. 60/670,180, filed on Apr. 11, 2005.

(75) Inventor: **Akemi Rhea**, Dallas, TX (US)

Publication Classification

Correspondence Address:
HAYNES AND BOONE, LLP
901 MAIN STREET, SUITE 3100
DALLAS, TX 75202 (US)

(51) **Int. Cl.**
B65D 73/00 (2006.01)
B65D 71/00 (2006.01)
(52) **U.S. Cl.** **206/494**; 206/233; 206/389

(73) Assignee: **Imeka Enterprises, Inc.**

(57) **ABSTRACT**

(21) Appl. No.: **11/402,453**

A disposal envelope for a moistened wipe comprises a thin liquid impervious sheet forming a pocket, a moistened wipe accommodated inside the pocket, an adhesive closure, and the pocket being rolled up along with the moistened wipe and secured in the rolled-up form with the adhesive closure.

(22) Filed: **Apr. 11, 2006**

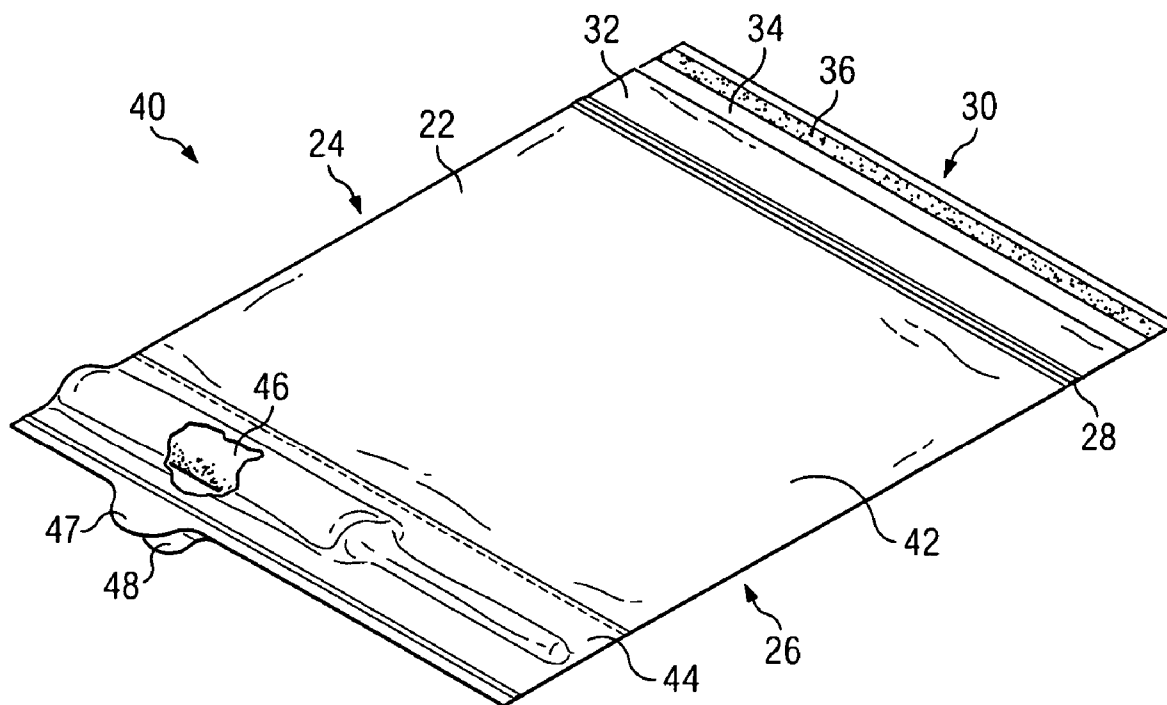

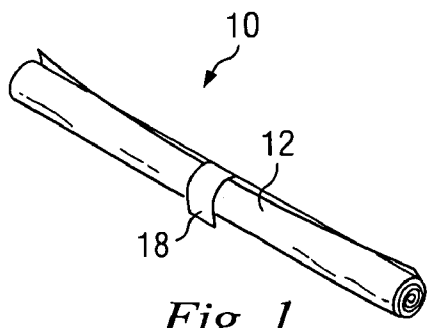

Fig. 1

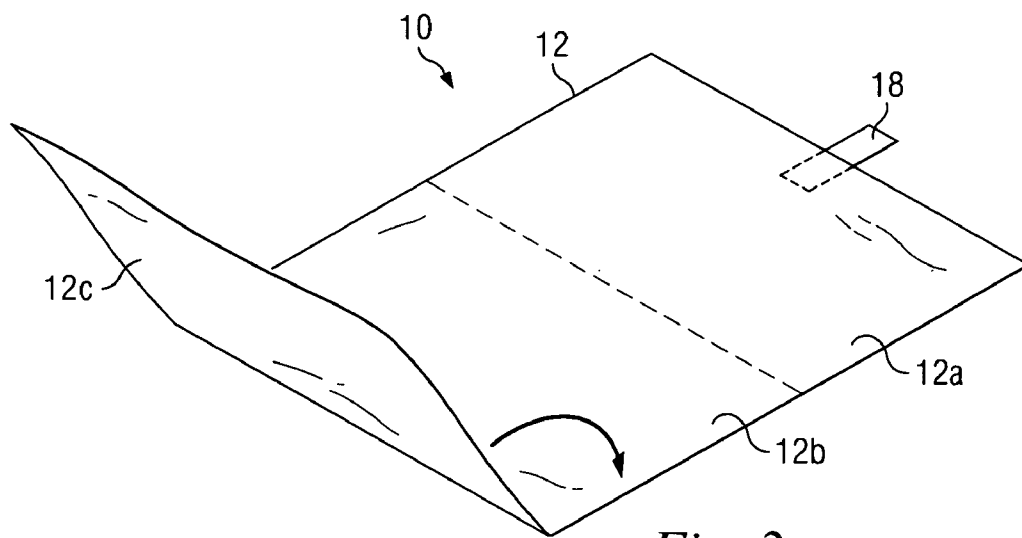

Fig. 2

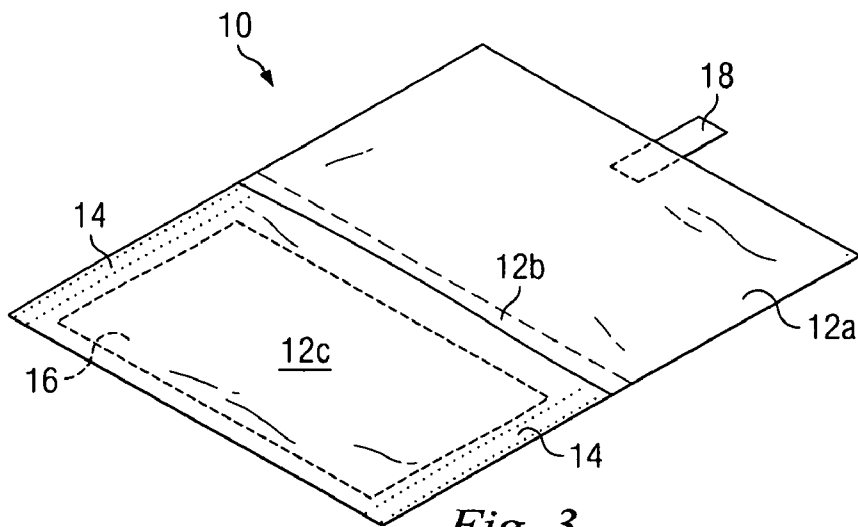
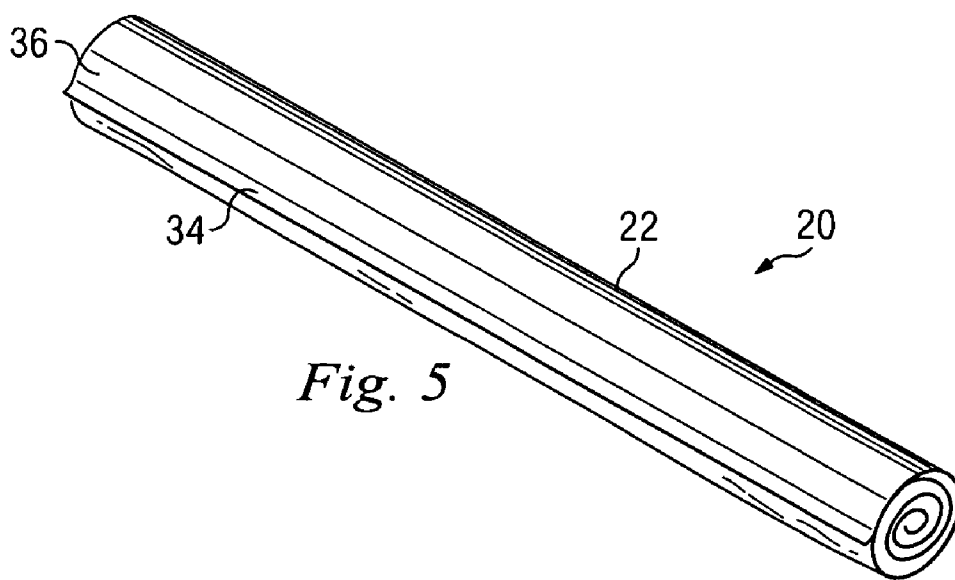
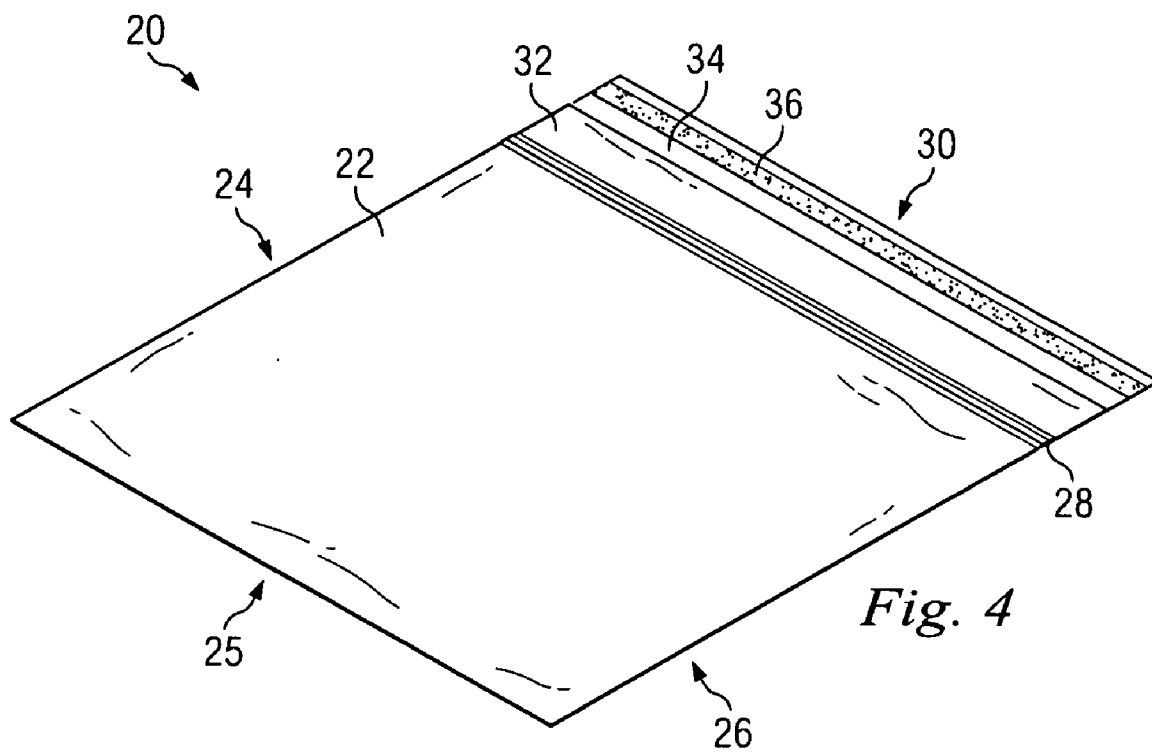

Fig. 3



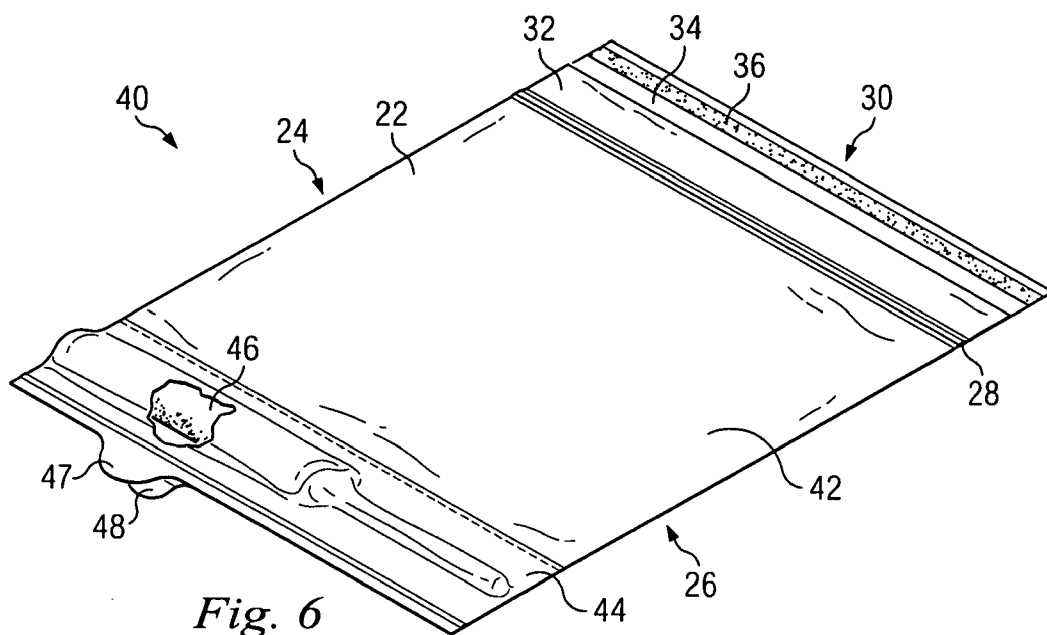

Fig. 6

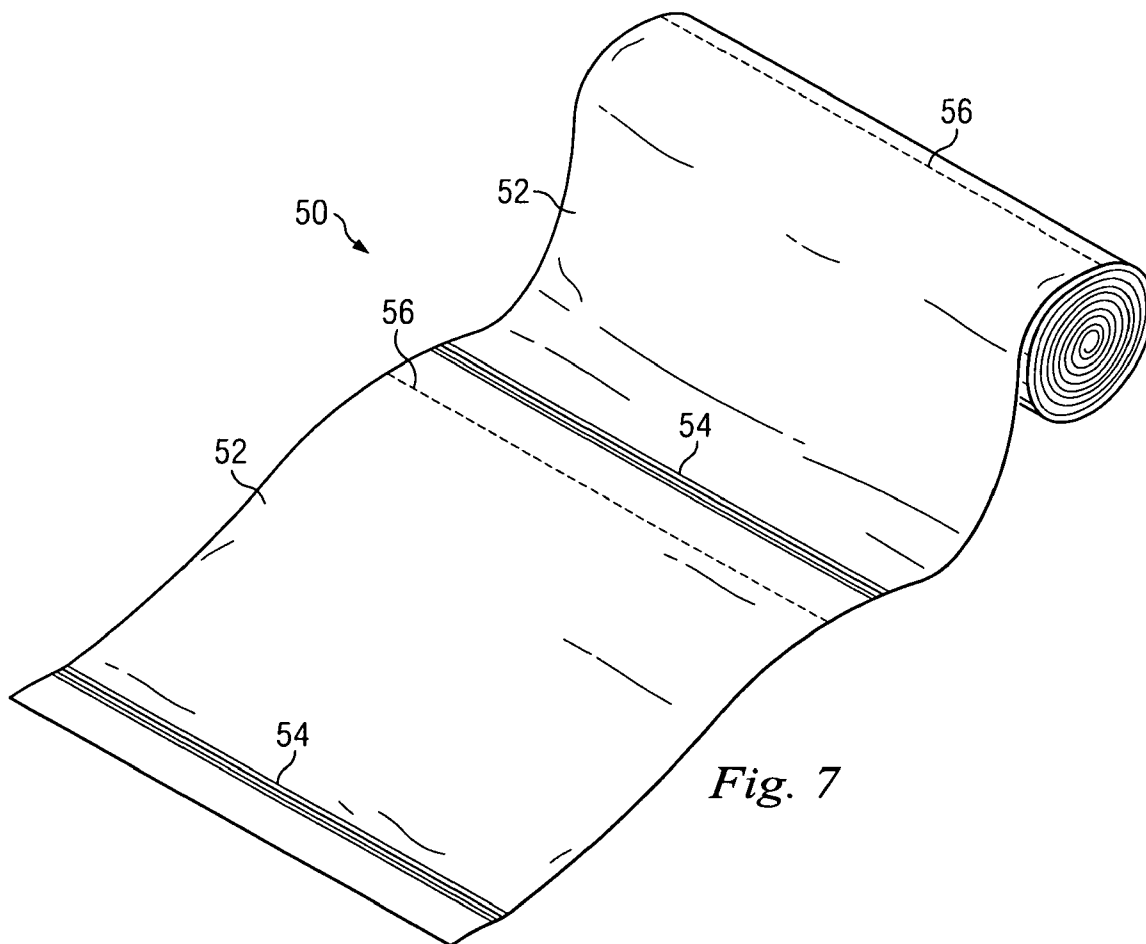

Fig. 7

FEMININE PRODUCT DISPOSAL ENVELOPE WITH CLEANSING WIPES

DETAILED DESCRIPTION

RELATED PATENT APPLICATION

[0001] This patent application claims the benefit of provisional patent application no. 60/670,180 filed on Apr. 11, 2005, and entitled *Portable Feminine Accessory Storage and Carrying System*, incorporated herein by reference.

[0002] This patent application is related to co-pending patent application filed on Apr. 11, 2006, and entitled *Carrier for Feminine Hygiene Products*, incorporated herein by reference.

BACKGROUND

[0003] Moistened cleansing wipe products have become an important product category that has found a wide variety of applications for adults, children, and babies. These products are typically manufactured by impregnating sheets made of non-woven fabric with a suitable solution. Examples include hand wipes, face or body cleansing wipes, wipes for skin treatment, and skin conditioning wipes. Many women also prefer to use wipes impregnated with appropriate non-stinging cleansing liquid for hygienic cleaning of the vaginal area.

[0004] Feminine hygienic cleansing wipes are typically folded and packaged in very small tear-open pouches. Other moistened wipe products have been packaged in rectangular box-like containers and cylindrical containers. These bulky containers typically hold hundreds of the moistened wipes and are not meant to be portable or carried in a purse.

BRIEF DESCRIPTION OF THE DRAWINGS

[0005] Aspects of the present disclosure are best understood from the following detailed description when read with the accompanying figures. It is emphasized that, in accordance with the standard practice in the industry, various features are not drawn to scale. In fact, the dimensions of the various features may be arbitrarily increased or reduced for clarity of discussion.

[0006] FIG. 1 is a perspective view of an embodiment of a disposal envelope for hygienic wipes;

[0007] FIG. 2 is another perspective view of an embodiment of the disposal envelope for hygienic wipes in its unrolled state;

[0008] FIG. 3 is another perspective view of the disposal envelope for hygienic wipes in its unrolled state;

[0009] FIG. 4 is a perspective view of another embodiment of a disposal envelope for hygienic wipes in its unrolled state;

[0010] FIG. 5 is a perspective view of the embodiment of disposal envelope shown in

[0011] FIG. 4 in its rolled state;

[0012] FIG. 6 is a perspective view of another embodiment of a disposal envelope having a second compartment for storing a tampon in its unrolled state; and

[0013] FIG. 7 is a perspective view of another embodiment of a roll of contiguous disposal envelopes.

[0014] FIGS. 1-3 are perspective views of an embodiment of a disposal envelope 10 for hygienic wipes. disposal envelope 10 is constructed of a thin liquid impervious sheet 12 that is folded along two lines into three substantially identically-sized portions—top portion 12a, center portion 12b, and bottom portion 12c. The liquid impervious sheet 12 may be a thin film of polyethylene, polyvinyl or any other suitable plastic film that is operable to provide a moisture barrier. The bottom portion 12c of liquid impervious sheet 12 is folded over center portion 12b, and affixed thereto by a suitable adhesive, heat sealing or another suitable method around the periphery along two opposing sides to form sealed edges 14. Accordingly, affixed center and bottom portions 12b and 12c form a pocket or pouch which may be used to accommodate one or more moistened hygienic wipe 16 shown in phantom in FIG. 3. Moistened hygienic wipe 16 may be impregnated with a cleansing solution or another suitable liquid.

[0015] With the hygienic wipe 16 in place inside the pocket formed by center and bottom portions 12b and 12c, top portion 12a of liquid impervious sheet 12 may be folded over the pocket and then the entire envelope 10 may be rolled into a tubular form and then secured by an adhesive closure 18. Adhesive closure 18 may be a tab that has an adhesive applied on one side or another suitable means such as a hook and loop closure, for example. The adhesive closure is preferably reusable. The rolled envelope 12, along with the moistened wipe 16 contained therein, may be packaged and distributed in a cardboard box, or be distributed and marketed as a part of a feminine hygiene carrier system described in the above-identified co-pending patent application entitled *Carrier for Feminine Hygiene Product*. The liquid impervious nature of sheet 12 keeps moistened hygienic wipe 16 from drying out. The liquid impervious sheet is preferably opaque and may have decorative designs adorning the exterior surface thereof.

[0016] In operation, a user may carry rolled envelope 12 inside the carrier referenced above, or inside her purse. The rolled envelope 12 is a small and discrete package that can be easily accommodated in any purses, tote bags, or backpacks. To use, the user may simply unroll the envelope 12 and remove the hygienic wipe from the pocket for use. The user may then use the now empty pocket to dispose of used tampon, tampon applicator, feminine pad, or any other soiled object. Adhesive tab 18 may be used to seal the envelope to keep the contents more securely contained. Therefore, soiled feminine hygiene products may be contained and discarded in a tidy manner. The liquid impervious nature of sheet 12 helps to keep the content from leaking and ensures that the entire package stays tidy.

[0017] Although disposal envelope 12 is described and shown herein as having a tri-fold construction (with two fold lines and three portions), disposal envelope 12 may have a bi-fold construction with one fold line and two portions folded over one another and sealed along two opposing sides to form a pocket. Further, although the three portions of disposal envelope 12 are preferably substantially equal-sized, envelope 12 may be constructed with substantially equally- sized center and bottom portions 12b and 12c, and a top portion 12a that is smaller or larger than the pocket formed by portions 12b and 12c.

[0018] Disposal envelope 12 may employ, instead of adhesive tab 18, other means of securing the rolled-up envelope. For example, the two ends of the rolled-up envelope may be heat sealed or by another suitable means that is easily separated by the user to unroll the envelope.

[0019] FIG. 4 is a perspective view of another embodiment of a disposal envelope 20 for hygienic wipes in its unrolled state. Disposal envelope 20 comprises a liquid impervious bag 22 having three closed sides 24-26. Disposal envelope 20 comprises a reclosable seal 28 across an open end 30 of the bag 22. Reclosable seal 28 may be a zip lock-type closure or another suitable closure. Two opposed flaps 32 and 34 extend from closure 28 at open end 30 of bag 22. Flaps 32 and 34 facilitate a user in pulling apart the zip lock-type closure in order to access contents stored in disposal envelope 20. Flap 34 may extend further from closure 28 than flap 32 and may comprise an adhesive strip 36 on its side facing flap 32. Adhesive strip 36 is preferably reusable. Disposal envelope 20 is used to contain one or more hygienic wipes. Bag 22 is preferably opaque and may have decorative designs adorning the exterior of the bag.

[0020] FIG. 5 is a perspective view of the embodiment of disposal envelope 20 shown in FIG. 4 in its rolled state. In the rolled state, adhesive strip 36 may be used to adhere flap 34 to bag 22 so that it does not become unrolled. The hygienic wipes are folded in such a way so that the rolled disposal envelope 20, with the one or more wipes contained therein, has a smooth and slim profile and does not have lumps where the wipes are located within the bag.

[0021] In operation, a user may carry rolled envelope 20 inside the carrier referenced above. The rolled envelope 20 is a small and discrete package that can be easily accommodated in any purses, tote bags, or backpacks. To use, the user may simply unroll the envelope 20, open closure 28 and remove the hygienic wipes for use. The user may then use the now empty bag to dispose of used tampon, tampon applicator, feminine pad, or any other soiled object. Closure 28 may then be used to reseal the envelope to keep the contents more securely contained. Therefore, soiled feminine hygiene products may be contained and discreetly discarded in a tidy manner. The liquid impervious nature of bag 22 helps to keep the content from leaking and ensures that the entire package stays tidy until it is disposed of.

[0022] FIG. 6 is a perspective view of another embodiment 40 of a disposal envelope having a second compartment for storing a feminine product. Disposal envelope 40 comprises a first compartment 42 that stores a moistened cleansing wipe and a second compartment 44 that stores a feminine product such as a tampon 46. Second compartment 44 preferably has an opening that opens in a direction opposite that of first compartment 42. The second compartment may have a sealed opening. Flaps 47 and 48 may be provided to facilitate easy opening of the seal across the opening of second compartment 44. Unlike first compartment 42, the opening of second compartment 44 does not require a reclosable seal.

[0023] FIG. 7 is a perspective view of another embodiment of a roll 50 of contiguously-coupled disposal envelopes 52. Each disposal envelope 52 comprises a reclosable seal 54 such as a zip-lock type closure. The disposal envelopes are easily separated by tearing along perforations 56 disposed between successive disposal envelopes. The

disposal envelopes may be easily dispensed on a roller dispenser. Each disposal envelope 52 in the roll may contain one or more moistened wipe in a first compartment and/or a feminine product such as a tampon in a second compartment as described above.

[0024] Alternatively, the disposal envelopes may be stored and dispensed from a box of suitable size with a dispensing opening. The disposal envelopes may be arranged in an overlap manner in the box so that as one envelope is removed by a user through the dispensing opening, the next envelope is pulled through the opening much like how facial tissues are dispensed.

[0025] Unlike conventional moistened wipe packaging that are typically very small tear-open packages, the disposal envelope described above is substantially larger and can be reused and resealed to discard soiled feminine products. The moistened wipe contained in the disposal envelope are not folded into a tiny square that is often a challenge to unfold as in conventional wipe packages. Therefore, the disposal envelope is easy to unfurl and the moistened wipe contained therein is easy to unfold and use. In the embodiment where the disposal envelope has two compartments, one containing a wipe and the other containing a tampon, the user can easily extract the wipe and the tampon for use and then use the resealable first compartment to dispose of soiled feminine products.

[0026] Although embodiments of the present disclosure have been described in detail, those skilled in the art should understand that they may make various changes, substitutions and alterations herein without departing from the spirit and scope of the present disclosure. Accordingly, all such changes, substitutions and alterations are intended to be included within the scope of the present disclosure as defined in the following claims. In the claims, means-plus-function clauses are intended to cover the structures described herein as performing the recited function and not only structural equivalents, but also equivalent structures.

What is claimed is:

1. A disposal envelope for a moistened wipe, comprising:
 - a thin liquid impervious sheet forming a pocket;
 - a moistened wipe accommodated inside the pocket;
 - an adhesive closure; and
 - the pocket being rolled up along with the moistened wipe and secured in the rolled-up form with the adhesive closure.
2. The disposal envelope of claim 1, wherein the thin liquid impervious sheet comprises top, center and bottom portions, the center and bottom portions being folded and secured over one another to form the pocket.
3. The disposal envelope of claim 2, wherein the center and bottom portions are affixed along a periphery to form the pocket.
4. The disposal envelope of claim 2, wherein the top, center, and bottom portions are substantially equal-sized.
5. The disposal envelope of claim 2, wherein the center and bottom portions are substantially equal-sized.
6. The disposal envelope of claim 5, wherein the top portion is substantially smaller than the center and bottom portions.

7. The disposal envelope of claim 2, wherein the pocket comprises a heat sealed periphery to form the pocket.

8. The disposal envelope of claim 2, wherein the pocket comprises an adhesive-held periphery to form the pocket.

9. The disposal envelope of claim 1, wherein the thin liquid impervious sheet comprises first and second portions folded and secured over one another to form the pocket.

10. The disposal envelope of claim 1, wherein the adhesive closure comprises an adhesive tab.

11. The disposal envelope of claim 1, wherein the adhesive closure comprises an adhesive strip.

12. The disposal envelope of claim 1, further comprising a reclosable closure across an open end of the pocket.

13. The disposal envelope of claim 12, wherein the reclosable closure is a zip lock- type closure.

14. The disposal envelope of claim 1, further comprising a second pocket for storing a feminine hygiene product.

15. The disposal envelope of claim 14, wherein the second pocket comprises two flaps for facilitating opening of the second pocket.

16. A liquid-impervious disposal envelope, comprising:

a first compartment accommodating a moistened wipe therein; and

a second compartment coupled to the first compartment accommodating a feminine product, an open end of the first compartment facing an opposite direction of an open end of the second compartment.

17. The disposal envelope of claim 16, wherein the first and second compartments being rolled up along with the moistened wipe and feminine product and secured in the rolled-up form with a closure tab.

18. The disposal envelope of claim 16, wherein the first compartment is reusable to contain and discard soiled feminine products after removal of the moistened wipe.

19. The disposal envelope of claim 17, wherein the closure tab comprises a reusable adhesive tab.

20. The disposal envelope of claim 19, wherein the adhesive closure comprises an adhesive strip.

21. The disposal envelope of claim 16, further comprising a reclosable closure across an open end of the first compartment.

22. The disposal envelope of claim 21, wherein the reclosable closure is a zip lock- type closure.

23. The disposal envelope of claim 16, wherein the second compartment comprises two flaps for facilitating opening of the second compartment.

24. The disposal envelope of claim 16, wherein the second compartment accommodates a tampon.

25. A plurality of disposal envelopes comprising:

a roll of contiguously-coupled disposal envelopes with perforations disposed between successive disposal envelopes; and

each disposal envelope comprising a first compartment and a reclosable closure across its opening.

26. The plurality of disposal envelopes of claim 25, wherein each disposal envelope further comprises a moistened wipe contained within the first compartment.

27. The plurality of disposal envelopes of claim 26, wherein each disposal envelope further comprises a second compartment coupled to the first compartment and accommodating a feminine product, an open end of the second compartment facing an opposite direction of the opening of the first compartment.

28. The plurality of disposal envelopes of claim 26, wherein the first compartment is reusable to contain and discard soiled feminine products after removal of the moistened wipe.

29. A plurality of disposal envelopes comprising:

the disposal envelopes arranged in an overlapping manner inside a container having a dispensing opening;

each disposal envelope comprising a first compartment and a reclosable closure across its opening; and

each disposal envelope further having a moistened wipe contained within the first compartment.

30. The plurality of disposal envelopes of claim 29, wherein each disposal envelope further comprises a second compartment coupled to the first compartment and accommodating a feminine product, an open end of the second compartment facing an opposite direction of the opening of the first compartment.

31. The plurality of disposal envelopes of claim 29, wherein the first compartment is reusable to contain and discard soiled feminine products after removal of the moistened wipe.

* * * * *