

(No Model.)

3 Sheets—Sheet 1.

J. S. ROBLIN.
SAFETY CAR STOVE.

No. 385,428.

Patented July 3, 1888.

Fig. 1.

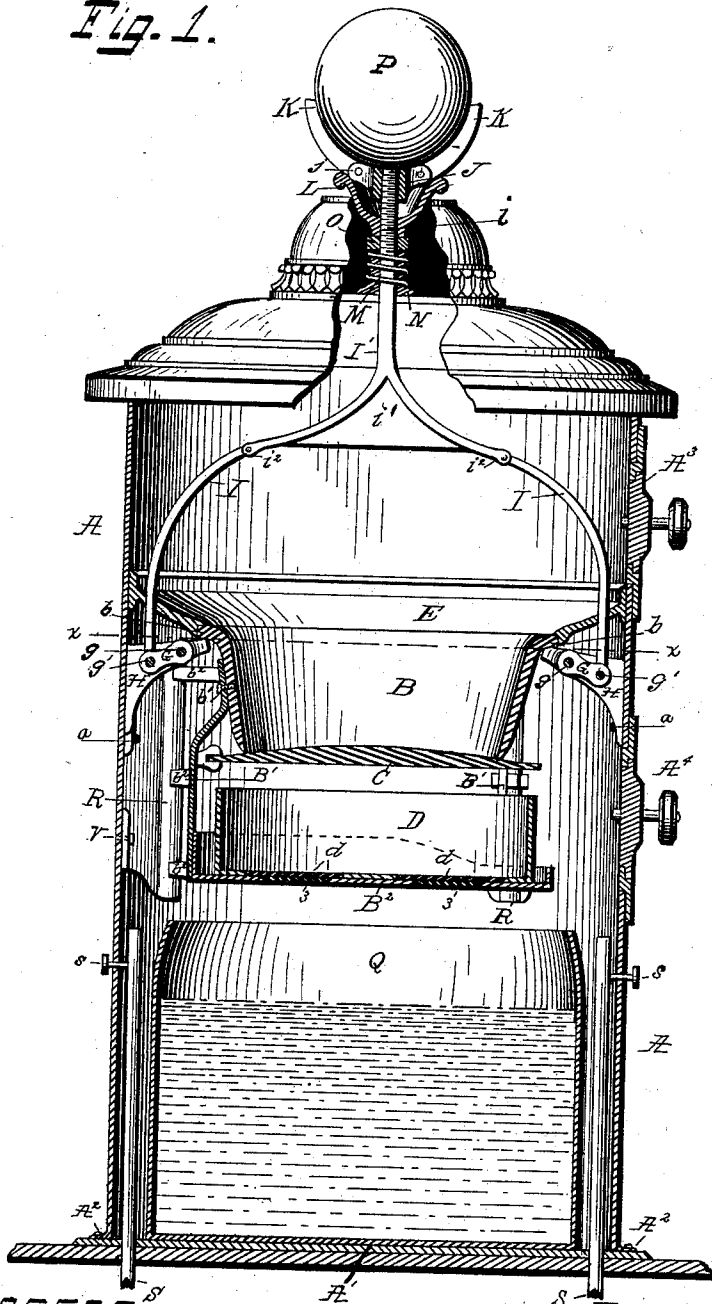

Witnesses
 W. A. Barnes.
 Wm. A. Brereton

Inventor.
 John Stanley Roblin.
 By J. P. Hallmads,
 Att'y

(No Model.)

3 Sheets—Sheet 2.

J. S. ROBLIN.
SAFETY CAR STOVE.

No. 385,428.

Patented July 3, 1888.

Fig. 2.

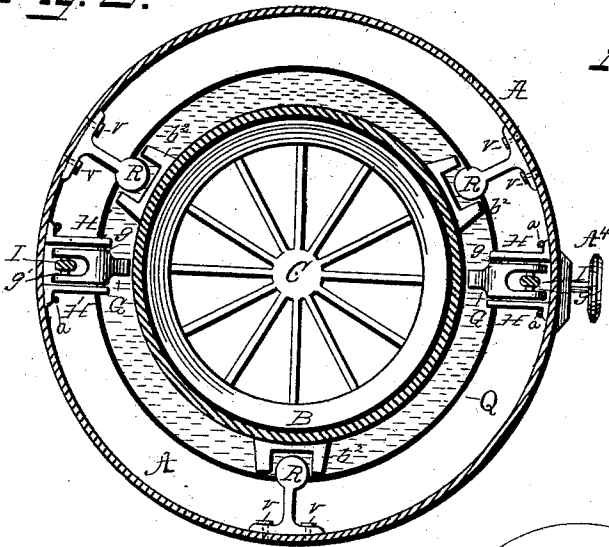

Fig. 3.

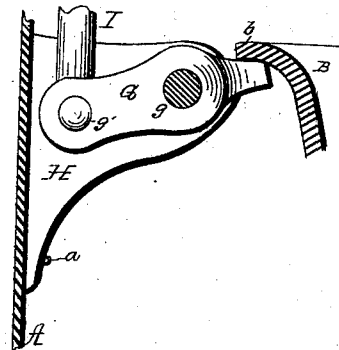

Fig. 4.

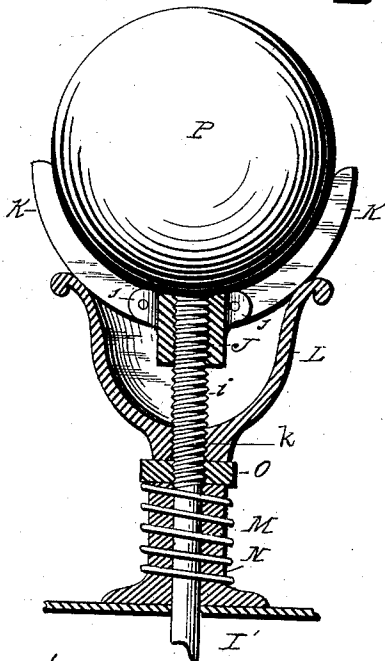

Fig. 5.

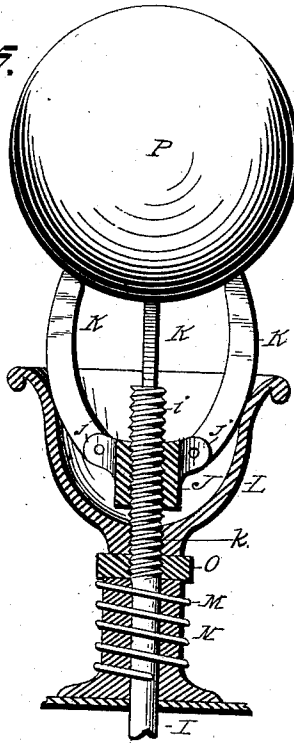
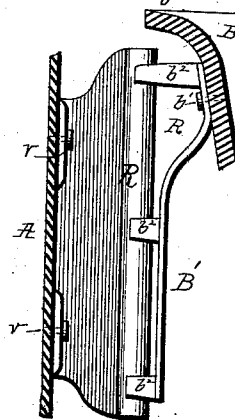

Fig. 12.



WITNESSES
Wm. A. Barnes,
Wm. A. Brereton

INVENTOR,
John Stanley Roblin,
By J. W. Hallmridge
Att'y

(No Model.)

3 Sheets—Sheet 3.

J. S. ROBLIN.
SAFETY CAR STOVE.

No. 385,428.

Patented July 3, 1888.

Fig. 6.

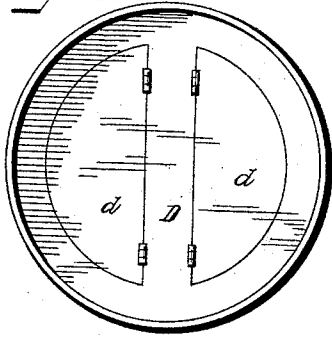

Fig. 10.

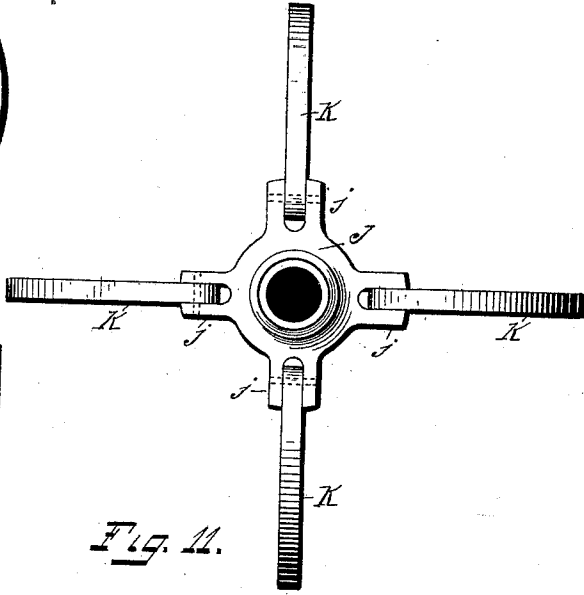

Fig. 7.

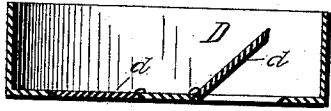

Fig. 8.

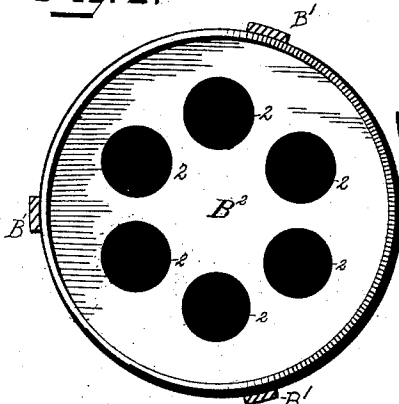

Fig. 11.

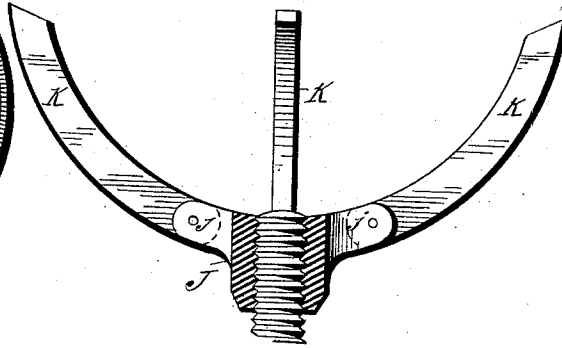
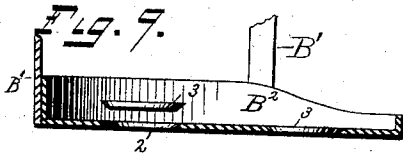

Fig. 9.



WITNESSES.

W. A. Barnes,
Wm. F. Brereton

Inventor.

John Stanley Roblin.
By J. P. Hallmads
Att'y

UNITED STATES PATENT OFFICE.

JOHN STANLEY ROBLIN, OF BAY CITY, MICHIGAN, ASSIGNOR TO SELWYN EDDY, JOHN F. EDDY, AND STEPHEN H. ROBLIN, ALL OF SAME PLACE.

SAFETY CAR-STOVE.

SPECIFICATION forming part of Letters Patent No. 385,428, dated July 3, 1888.

Application filed August 27, 1887. Serial No. 248,057. (No model.)

To all whom it may concern:

Be it known that I, JOHN STANLEY ROBLIN, a citizen of the United States, residing at Bay City, in the county of Bay and State of Michigan, have invented certain new and useful Improvements in Safety Car-Stoves; and I do hereby declare the following to be a full, clear, and exact description of the invention, such as will enable others skilled in the art to which it appertains to make and use the same.

This invention has for its object to so construct a stove for railway-cars that the fire therein will be immediately extinguished and the highly-heated portions of the stove rapidly cooled off when the car is tilted to an unusual degree or subjected to any extraordinary shock or jar, so that all danger of igniting the cars or surrounding objects will be obviated.

To this end my invention consists in suspending that portion of the stove constituting the fire-pot, grate, and ash-pit of the stove upon movable supports held normally so as to sustain the said parts by a removable weight and suitable connecting mechanism, the said parts being so arranged that they will be shifted by means of a spring or other device so as to trip the supports and release them (said fire-pot, grate, and ash-pit) and drop the whole into a tank below containing water, so as to immediately extinguish the burning fuel and rapidly cool off the parts mentioned, and thus prevent setting fire to the car or other surrounding objects.

My invention further consists in certain improved mechanism whereby the position of the weight may be so regulated that it will drop from its seat when the stove assumes any desired angle to a horizontal plane, in order that the parts may be arranged to drop when the car is thrown at any degree from its perpendicular position, as more fully hereinafter explained.

My invention still further consists in certain details of construction for effecting the hereinbefore-mentioned objects, as will be more fully hereinafter set forth, and specifically pointed out in the claims.

In the drawings, Figure 1 represents a vertical central transverse sectional elevation, and Fig. 2 a transverse sectional plan on the line

xx of Fig. 1 of the same; Fig. 3, a detail sectional view, on an enlarged scale, (about one-half full size,) of the pivoted trigger-catch for supporting the fire-pot and its accessories; Figs. 4 and 5, detail views in sectional elevation of the counterpoise weight-supporting mechanism with the weight in position thereon; Fig. 6, a plan, and Fig. 7 a vertical central sectional elevation, of the ash-pan; Fig. 8, a plan, and Fig. 9, a vertical central sectional elevation, of the base-plate or support for the ash-pan. Fig. 10 is a plan, and Fig. 11 a sectional elevation, on an enlarged scale, of the ball-holder; Fig. 12, a detail sectional view, on an enlarged scale, of the guide for the fire-pot and ash-pan.

Similar letters of reference indicate like parts in the several views.

A is the shell or case forming the stove proper, which is formed with a base-plate, A', and flanged rim A², by which it may be secured to the floor of a car.

B is the fire-pot, C the grate, and D the ash-pan. These parts may be of any desired size or pattern, and the case may have external ornamentation, and at proper positions through the same are formed openings supplied with doors, the one A³ for supplying fuel to the fire-pot and the one A⁴ for the removal of the ash-pan. Around the interior of the case A is a flange, E, for closing the space between the casing and fire-pot, and thereby prevent the escape of coals over the top edge of said fire-pot. The fire-pot B is formed with a flange, *b*, at its top circumferential edge, by which it is supported in position within the case A, and depending from this fire-pot are three straps, B', which are secured to the top edge thereof, as at *b'*, and to the lower ends of which straps is secured a plate, B², for retaining the ash-pan D.

G G are dogs or catches pivoted at *g* within brackets H, which in turn are secured to the inside of the casing A at opposite sides thereof by rivets, as at *a*. Two or more of these dogs G may be employed, and their outer ends are adapted to engage beneath the lip or flange *b* of the fire-pot B, and thereby form the supporting medium for said fire-pot.

I I are rods, which are united at their top ends into a common stem, I', by a web, as at

i, Fig. 1, and each is jointed, as at *i*², and at their lower ends they are pivoted to the inner ends of the dogs G G, as at *g*'. The stem or united portion I' of the rods I passes upward through the top of the stove-case A and terminates in a threaded end, *i*, upon which is received a nut, J, which nut, as shown in Figs. 10 and 11, is formed with a series of radially-projecting lugs, *j*, between which is pivoted a series of curved fingers, K, for the purposes as will presently appear. Beneath this nut J is a hollow cup-shaped disk, L, also held upon the threaded end *i* of the stem I', within which disk the nut J is received, as shown in Figs. 1, 4, and 5, and the hole *k* at the bottom of said disk is screw-threaded to receive the threaded portion *i* of the stem I', whereby said disk may be adjusted upon said stem and held in its adjusted position.

M is a spiral spring upon a thimble, N, which thimble is secured upon the top of the stove and surrounds the stem I'. This spring M at its bottom bears against the base-flange of the thimble N and at its top against a jam-nut, O, on stem I', whereby said stem is held upward. P is a loose counterpoise-weight, preferably of spherical form, which is held upon the top of stem I' within the grasp of the fingers K of the nut J.

This completes the description of the fire-pot and the manner of supporting the same. I will now proceed to point out the manner in which said fire-pot is held centrally within the stove-case, and in case of the disengagement of the supporting-dogs therefrom its proper movement is assured, to wit: At equidistant points around the outer top edge of the fire-pot B is secured, as at *b*', three depending straps, B', to which are cast or formed integral therewith lugs or ears *b*². At the bottom of these straps B' is, as before stated, attached the base-plate B², to receive the ash-pan D, and immediately opposite the positions of these straps, so that they will be between the lugs *b*² thereof, are arranged guide-bars R, which are of T-rail form in cross-section, and are secured in vertical position through their flanges to the case A by rivets, as at *r*. Three of these guides are employed, and they are of such length as to extend from the top edge of the fire-pot to the bottom of the ash-pan, and their function is, in addition to that of holding said fire-pot and ash-pan centrally within the stove-case, to form a guide way or track whereby the proper descent of the fire-pot and its ash-pan to the bottom of the stove-case is assured immediately upon the release of the supporting-dogs from engagement therewith.

This completes the description of the fire-pot, its supports, guides, and devices employed to disengage said supports. I will now proceed to set forth the means for extinguishing the fire in the fire-pot immediately upon the release therefrom of its supporting-dogs as follows: A tank, as at Q, is formed at the bottom of the case A, immediately beneath the base-

plate B², of sufficient size to receive and completely inclose said fire-pot and its ash-pan. This tank is adapted to contain water or any chemical fire-extinguishing compound, and it may either be separate from the stove-case, as shown in Fig. 1, or the stove-case itself may form the tank.

Turning again to the ash-pan D, Figs. 6 and 7, it will be seen that the bottom thereof is formed of two hinged sections, *d d*, which open upward, and that this ash-pan rests upon the base-plate B², which is also, as shown in Figs. 8 and 9, formed with a series of holes or openings, 2, whose edges flare upward, and within which are fitted lids or covers 3, for the purposes as will be presently explained.

The operation is as follows: The normal position of the parts being as shown in Fig. 1, the stove may be used for heating as ordinarily, care being taken that the tank at the bottom thereof is constantly supplied with water or any chemical fire-extinguishing compound. In this condition the parts remain until an accident occurs sufficient to disengage the trigger-catches G from their engagement with the fire-pot, which is effected in this manner: Should the car leave the track or tip over, so that its perpendicular is destroyed, or encounters such a shock that the ball-weight P will be dislodged from its embracing-arms K, the resilience of the spring M, which had been overcome by said weight, will be exerted upon the nut O, and thereby force the stem I', to which said nut is fixed, upward and through said stem I' and its branch rods I, draw upon the pivoted catches G and disengage them from beneath the flange *b* of the fire-pot B, which, now being entirely unsupported, will immediately drop into the water-tank beneath it and squelch the fire therein.

Because of the base-plate B² of the fire-pot being supplied with the openings 2 and the bottom of the ash-pan D being formed with upwardly-acting hinged sections *d d*, the immediate upward entrance of water through these parts, so as to reach the fire-pot, is assured, and, owing to the vertical guide-bars R, the proper entrance within the water-tank of the fire-pot is the result, even should the stove be at somewhat of an angle.

The top edge of the water-tank may be curved inward, as shown in Fig. 1, to confine the fluid therein, and instead of extending the draft-supply pipes up through the floor of the car they may extend from any other point, through the wall of the stove, or be otherwise arranged as found to accomplish the best results. The grate of the fire-pot may also be of the usual shaking or rocking form and be operated from the outside of the case. A suitable pipe may also be connected to the top of the water-tank and extend through the wall of the stove, whereby to keep the said tank constantly supplied with water.

To prevent lateral displacement of the fire-pot and the entrance past the same of coals,

the flange E is provided, which extends at an angle around the inside of the case A and engages the top edge of the fire-pot B, as shown in Fig. 1.

5 The point at which the weight P is dislodged from its support may be regulated as desired by screwing the disk L up or down upon the stem I', whereby the arms or fingers K, which rest within said disk, will be opened
10 out or closed toward each other to a more or less degree, so that the ball-weight is either permitted to rest entirely within the embrace of said fingers, in which position it is difficult of removal, as shown in Figs. 1 and 4, or is
15 merely held upon the tips of said fingers, as shown in Fig. 5, in which instance it may be easily dislodged.

If desired, the water-tank may be separate from the case A, as shown in Fig. 1, or the bottom part of the stove itself may be arranged
20 to contain water or other fluid.

The ball-weight is preferred, as such form will be less liable to hang, and it is of such weight as to overcome the resistance of the spring as
25 well as such weight as may be exerted upon the trigger-catch supports by the fire-pot.

The tension of the spring may be regulated by adjusting the jam-nut O upon the stem I', and to supply the necessary draft to the fire
30 pipes S S, having dampers therein, as at s, are provided, which extend up through the floor or side of the car and terminate near the top of tank O.

A certain portion of the top of the stove-case
35 may be hinged or otherwise fastened, so as to permit the free escape of steam and gases generated upon the immersion of the fire into the water-tank, and thereby relieve the danger of bursting of the stove or injury to passengers
40 by scalding.

It is obvious that the spring M may be omitted, as the weight of the fire-pot and its appendages will operate the tripping mechanism when the weight is discharged without the aid
45 of the spring; but I prefer to employ the spring, in order to operate the mechanism instantaneously upon the tipping of the stove.

Having thus fully described my invention, what I claim as new therein, and desire to secure by Letters Patent of the United States, is
50 as follows, viz:

1. The combination, with the fire-pot, grate and ash-pit detachably supported therein, the tank located at the bottom thereof, and the tripping mechanism, of a support located on the top of the stove and an adjustable seat and removable weight sustained by said support, whereby the weight may be discharged to release the fire-pot when the stove is tilted, substantially as specified.
60

2. The combination, with the triggers or movable supports which hold the fire-pot, of the vertical stem and the rods connecting the same with the said triggers, the cup-shaped disk mounted upon the upper end of said stem, the
65 adjustable nut, also mounted on said stem and located in the cup, and the curved fingers pivoted to said nut and arranged to ride in said cup, whereby an adjustable seat is formed for the weight in order to discharge it at any
70 angle of the stove and of a vertical line, substantially as specified.

3. The combination, with the casing of the stove and the fire-pot and ash-pit thereof, of the vertical guides on the inside of the casing, and the slotted lugs secured to the fire-pot section and arranged to slide on said guides to direct the detached fire-pot, grate, and ash-pit into the tank when released, substantially
75 as specified. 80

4. The combination, in a safety car stove, of the movable supports for detachably suspending the fire-pot, the ash-pit, and the connecting-straps, the vertical guides on the inside of the stove-casing, and the slotted lugs secured to
85 the straps and arranged to slide on said guides, substantially as specified.

5. In a safety car-stove, the combination, with the fire-pot B, of the pivoted catches G, rods I, pivoted to said catches and to stem I', the said stem I', weight P, and spring M, all constructed and arranged substantially as described.
90

6. The combination, with the stem I', having threaded end i, of the disk L, ball P, nut J, having lugs j, and the fingers K, pivoted to said lugs to support the ball, substantially as specified.
95

7. The combination of the ball or weight P, the fingers K, holding said weight, the disk L, whereby the fingers are adjusted, the stem I', to which the fingers are pivoted, the arms I, pivoted to the branches of the stem I', the trigger G, pivoted to the arms I and to suitable supports, the fire-pot B, normally held by the
100 triggers, the ash-pit D, and straps B', connecting it with the fire-pot, the lugs l', secured to the said straps, the guide-strips R, secured to the inner wall of the casing, and the tank Q, located below the ash-pit, the whole arranged
105 to operate substantially as specified, and for the purpose set forth. 110

In testimony whereof I hereby affix my signature in presence of two witnesses.

JOHN STANLEY ROBLIN.

Witnesses:

W. J. McCORMICK,
A. L. STEWART.