

Oct. 31, 1939.

F. L. HOESS

2,178,357

METALLIC BUILDING UNIT

Filed Sept. 1, 1938

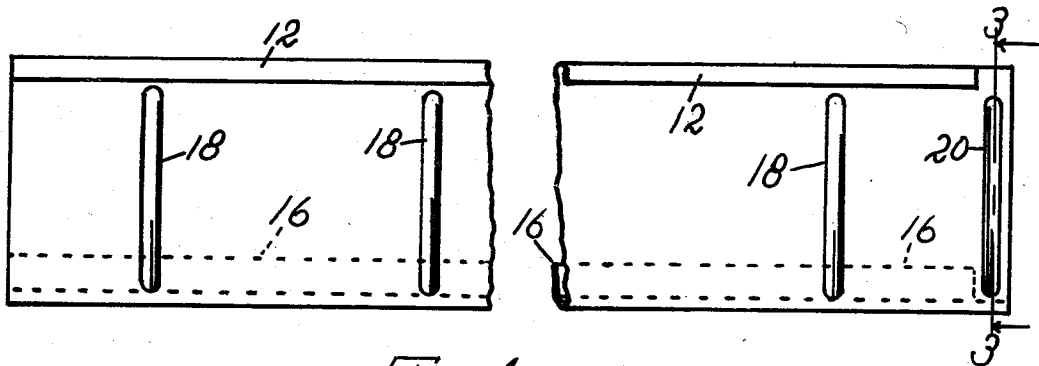

FIG. 1

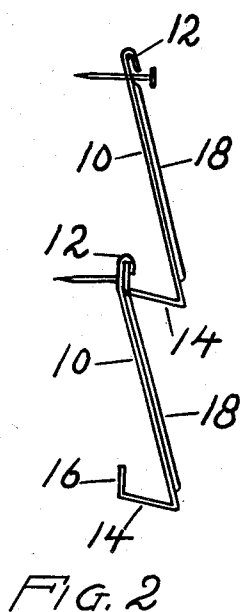

FIG. 2

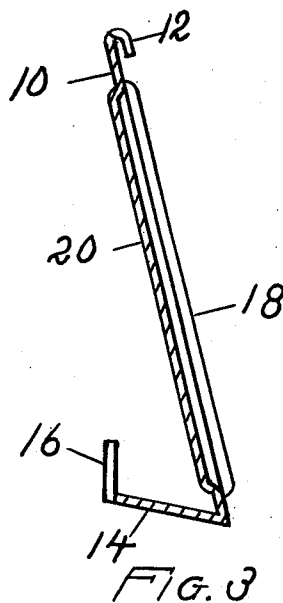

FIG. 3

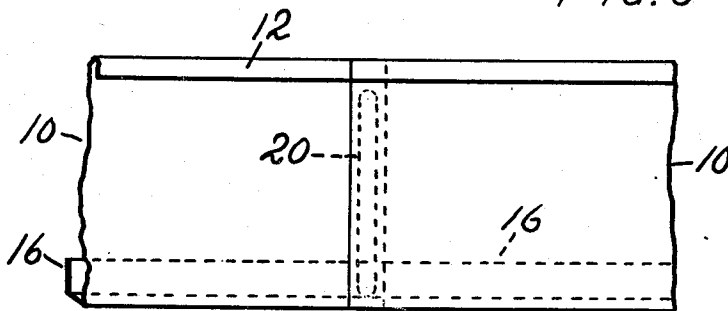

FIG. 4

FRANK L. HOESS  
INVENTOR.

BY *Leon T. Hooper*  
ATTORNEY.

# UNITED STATES PATENT OFFICE

2,178,357

## METALLIC BUILDING UNIT

Frank L. Hoess, Hammond, Ind.

Application September 1, 1938, Serial No. 227,934

7 Claims. (Cl. 189—86)

This invention relates to an improved building unit which is especially adaptable for use in covering certain types of buildings.

It is understood that various kinds of sheet metal roofing and siding have been employed in the past. However, use of the sheet metal units of the type here shown have for the most part been unsuccessful. The principal objection to this type of building unit has been that the joints could not be maintained weather proof. The edges of the material would buckle or warp leaving a large crack or opening. Consequently water would be driven through the opening to the back side of the member where it would quickly rust the material.

Water likewise would run along the horizontal portion of the assembled units and creep upwardly into the horizontal joints. In as much as these parts could not be covered by a water proofing such as paint or the like, they quickly rusted away.

The present invention overcomes the difficulties encountered in the previous structures and at the same time provides an economical and sturdy unit.

One of the principal objects of advantage and importance resides in the provision of means for locking one section of the material to another.

Another and further important object of advantage is the provision of means for preventing separating or warping of the material at the overlapping end joints.

Another and still further important object of advantage resides in the provision of means for maintaining an adhesive or water proofing material between the portions forming an overlapping joint.

Still another object of advantage resides in the provision of means for preventing water from entering the longitudinal joints of the associated members.

Additional objects of advantage and importance will become apparent as the following detailed description progresses, reference being had to the accompanying drawing wherein—

Fig. 1 is a front elevational view of a building unit, parts thereof being broken away, which embodies the invention.

Fig. 2 is an end view of two of the units joined together.

Fig. 3 is a slightly enlarged section taken on line 3—3 of Fig. 1 looking in the direction indicated by the arrows.

Fig. 4 is a front elevational view of an end

joint, portions of the units being broken away.

As shown in the drawing:

The reference numeral 10 indicates generally a sheet metal strip which may be of any desired gauge or dimensions.

Formed of the upper edge of the strip 10 is a downwardly projecting flange 12. The inner surface of the flange 12 is in spaced apart relation with the outer or weather surface of the body of the sheet metal strip 10.

The lower portion of the sheet metal strip 10 is turned at an angle to the body of the strip and extends inwardly and slightly upwardly as indicated by the reference numeral 14, and as best shown in Figs. 2 and 3.

Formed of the lower edge of the strip 10 is a vertical flange 16. The vertical flange 16 when positioned in the rear of the downwardly projecting flange 12 cooperates to maintain the members in assembled relation, as is best shown in Fig. 2.

Formed in the body of the sheet metal strip 10 are a plurality of outwardly projecting ribs 18. The ribs 18 in addition to enhancing and reinforcing the strip also provide a locking means for maintaining the units in assembly. It is to be noted that when the units are assembled the upper ends of the ribs 18 are in engagement with the lower surface of the inwardly turned portion 14. This engagement is a positive bar to the downward movement of the portion 14 or the flange 16.

In the preferred embodiment of the invention a portion of each flange 12 and 16, at one end of the strip 10, is cut away, as is best shown in Fig. 1. The cut away portion of the flanges 12 and 16 allow the units to be lap-joined as is best shown in Fig. 4.

Formed in the sheet metal strip 10 closely adjacent the end and intermediate the cut away portions of the flanges 12 and 16 is a groove 20. The groove 20 in addition to reinforcing and stiffening the end and consequently the end joint also provides a suitable trough in which a sealing or water proofing element may be maintained in the joint.

It will be apparent from the foregoing that herein is provided a sturdy, efficient and extremely long-lived building unit which may be used on various types of buildings.

Moreover, it will be apparent that water will run to the outer and lowermost point of the strip 10 and not into the longitudinal joints formed by the association of the flanges 12 and 16.

It will also be apparent to those skilled in the

art to which the device appertains that numerous changes and alterations in construction and design may be made all without departing from the spirit or scope of this invention. Accordingly, it is understood that the patent granted hereon is not to be limited to the preferred embodiment here disclosed nor in any other manner except as necessitated by the terminology of the appended claims when given the range of equivalents to which they may be entitled.

I claim as my invention:

1. A building unit comprising a strip of metal, the upper longitudinal edge being turned downwardly to form a flange, a portion adjacent the lower edge of said strip being turned to the rear and inclining upwardly, a vertical flange projecting upwardly from said inclined member, and a verticle rib formed on the face of said metal strip, the upper end of said rib terminating a short distance below the downwardly turned upper edge of said strip.

2. A building unit comprising a strip of metal, the upper longitudinal edge being turned downwardly to form a flange, a portion adjacent the lower edge of said strip being turned to the rear and inclining upwardly, a plurality of ribs formed in said strip intermediate the upper and lower edge, said ribs providing means for preventing the separation of strips joined one to the other and a vertical flange projecting upwardly from said inclined member.

3. A building unit comprising a strip of metal, the upper longitudinal edge being turned downwardly to form a flange, a portion adjacent the lower edge of said strip being turned to the rear and inclining upwardly, a plurality of ribs formed in said strip intermediate the upper and lower edge, the upper end of said ribs providing a step for the next above associated strip, and a vertical flange projecting upwardly from said inclined member.

4. A building unit comprising a strip of metal, the upper longitudinal edge being turned down-

wardly to form a flange, a portion adjacent the lower edge of said strip being turned to the rear and inclining upwardly, means formed on said strip preventing its separation when operably joined to a like member, a sealing material receiving groove adjacent one end of said strip, and a vertical flange projecting upwardly from said inclined member.

5. A building unit comprising a strip of metal adapted to be associated with like strips, the upper longitudinal edge being turned downwardly to form a flange, a portion adjacent the lower edge of said strip being turned to the rear and inclining upwardly, locking means formed of portions of said associated strips, said locking means including a rib adapted to engage the lower portion of the next above associated strip and a vertical flange projecting upwardly from said inclined member.

6. A building unit comprising a strip of metal adapted to be associated with like strips, the upper longitudinal edge being turned downwardly to form a flange, a portion adjacent the lower edge of said strip being turned to the rear and inclining upwardly, locking means formed of portions of said associated strips, said locking means including an outwardly bulged portion of said strip adapted to engage a portion of the next above associated strip, a groove closely adjacent one end of said strip, and a vertical flange projecting upwardly from said inclined member.

7. A sheet metal building unit having one of its longitudinal edges bent inwardly and upwardly, said inwardly turned portion being inclined upwardly, the other longitudinal edge being bent outwardly and downwardly, deformed portions of said unit providing locking means preventing disengagement when operably joined to a like unit and means at one end of said unit to facilitate making a weather-tight joint with a like member.

FRANK L. HOESS.