

J. HALL.

DIBBER.

(Application filed Dec. 15, 1900.)

(No Model.)

4 Sheets—Sheet 1.

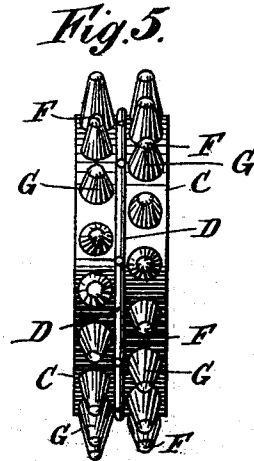
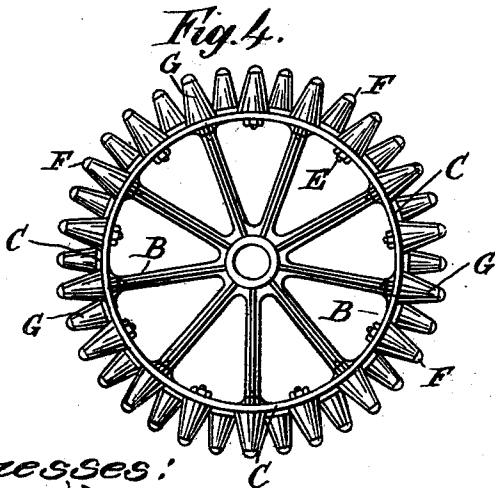
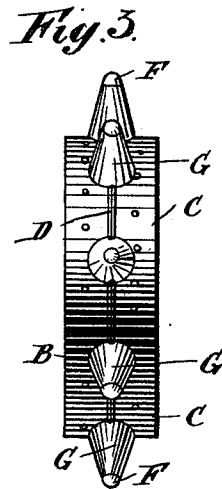
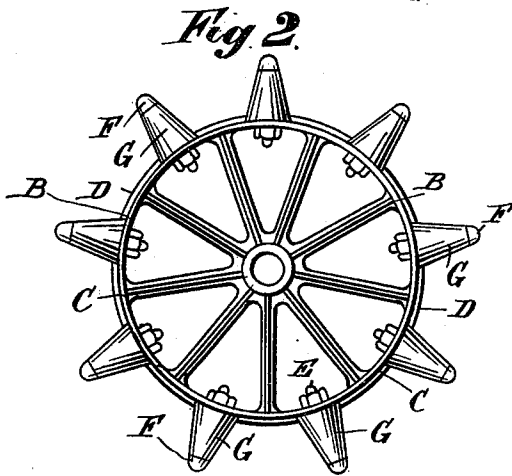
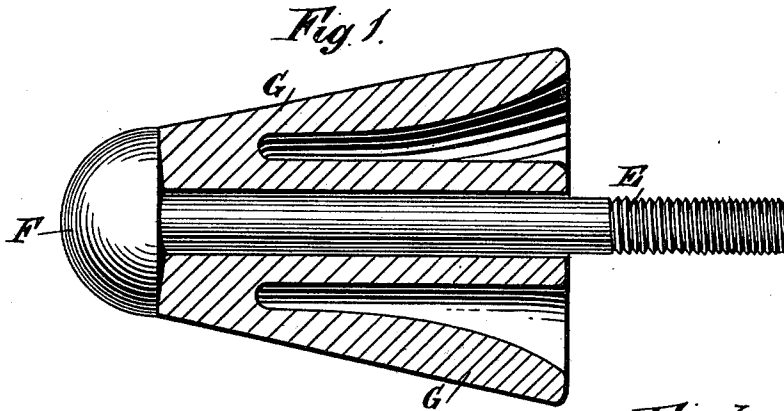

Witnesses:

J. B. [Signature]
[Signature]

Inventor
John Hall

By *James L. Norris*
 Atty.

No. 670,874.

Patented Mar. 26, 1901.

J. HALL.
DIBBER.

(No Model.)

(Application filed Dec. 15, 1900.)

4 Sheets—Sheet 2.

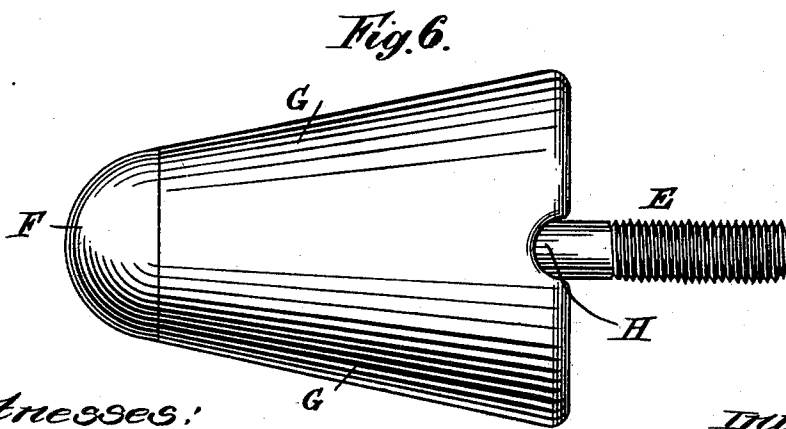
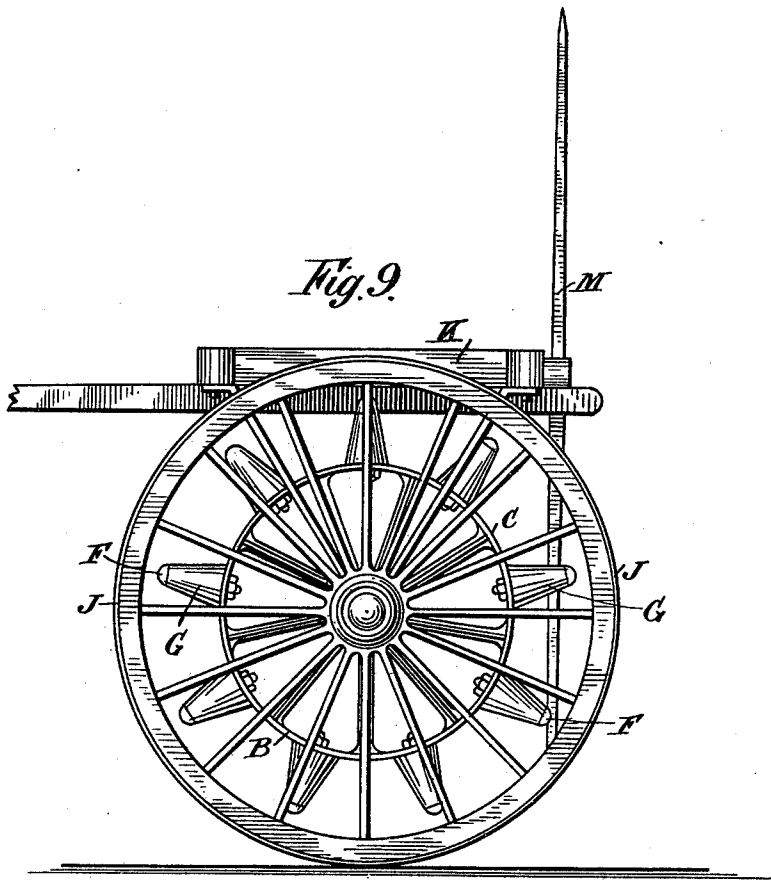

Witnesses:

F. B. Keefe
F. P. Parker

Inventor
John Hall

By *James L. Norris*
Atty.

No. 670,874.

Patented Mar. 26, 1901.

J. HALL.
DIBBER.

(Application filed Dec. 15, 1900.)

(No Model.)

4 Sheets—Sheet 3.

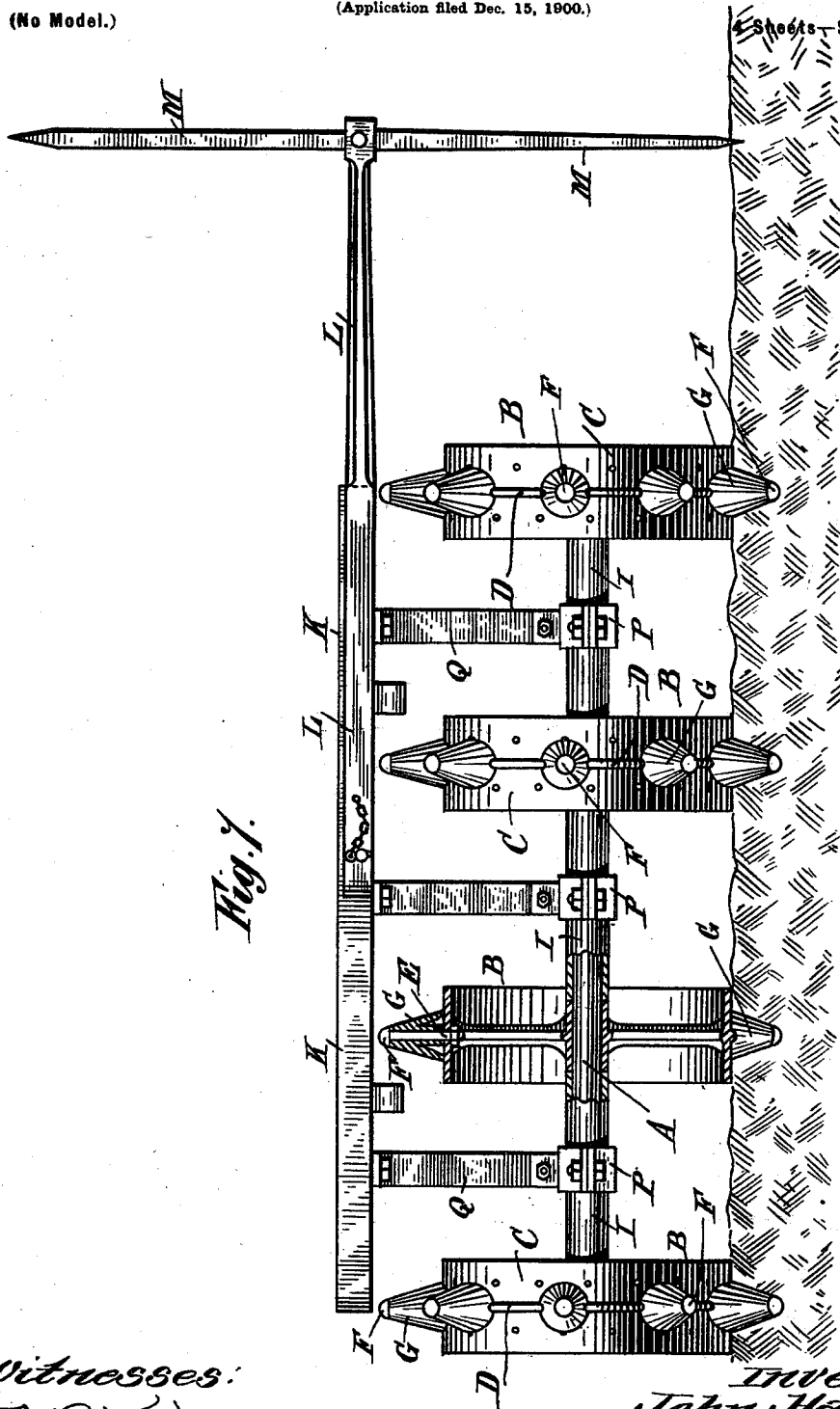

Fig. 7.

Witnesses:
J. B. Taylor
W. L. Parker

Inventor
John Hall

By *James L. Norris*
 Atty.

No. 670,874.

Patented Mar. 26, 1901.

J. HALL.

DIBBER.

(No Model.)

(Application filed Dec. 15, 1900.)

4 Sheets—Sheet 4.

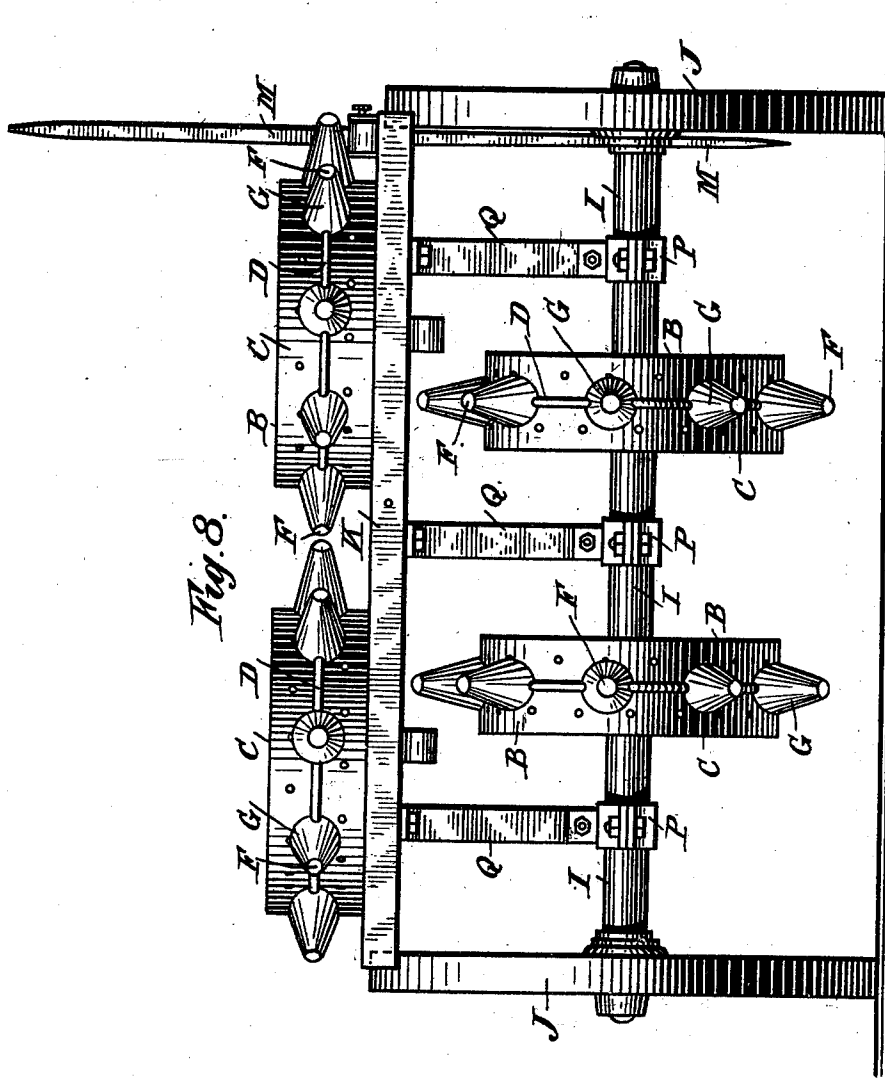

Fig. 8.

Witnesses:

F. B. Keefe
W. A. Keefe

Inventor
John Hall

By *James L. Norris*
Atty.

UNITED STATES PATENT OFFICE.

JOHN HALL, OF WOLVERHAMPTON, ENGLAND.

DIBBER.

SPECIFICATION forming part of Letters Patent No. 670,874, dated March 26, 1901.

Application filed December 15, 1900. Serial No. 40,062. (No model.)

To all whom it may concern:

Be it known that I, JOHN HALL, a subject of the Queen of Great Britain, residing at Burnhill Green, Wolverhampton, county of Stafford, England, have invented certain new and useful Improvements in the Construction of Dibbers, of which the following is a specification.

The object of this invention is to construct a dibbing-machine for agricultural and horticultural uses in a simple manner for preparing holes in the land for reception of potatoes, cabbage-plants, and other articles or seeds desired to be planted or sown.

My invention will be understood from the following description, aided by the accompanying drawings, in which—

Figure 1 is a sectional elevation of a dibber and bolt complete. Fig. 2 is a side view of a wheel complete with a single row of dibbers affixed. Fig. 3 is an edge view of Fig. 2. Fig. 4 is a side view of a wheel complete with a double row of dibbers affixed. Fig. 5 is an edge view of Fig. 4. Fig. 6 is an elevation of a dibber and bolt complete. Fig. 7 is an end view of a complete apparatus as ready for work in the field. Fig. 8 is an end view of a complete apparatus mounted ready for transport, with the removed wheels placed upon the top. Fig. 9 is a side view of the apparatus mounted for transport.

For the purpose of my invention I mount upon an axle A, at suitable distances apart, a number of wheels B, having on their periphery C a projecting rim or ridge D, and also provided with holes at the desired distances apart for the reception of pins or bolts E, which have spiked or mushroom heads F for retaining conical, oval, round, or other shaped hollow open-ended dibbers G in place, the spiked or mushroom heads F of the bolts E forming the piercing end of the dibber and the dibbers having slots H for engagement with the projecting ridge D on the wheel B to keep them in position and to produce stability with the wheel. The wheels B are kept apart by sleeves I, surrounding the axle A, and the two end wheels are capable of easy removal for the substitution of two larger ordinary wheels J, on which the apparatus can run, as at Figs. 8 and 9, when the machine is moving over roads or being trans-

ported from place to place, so that the dibbers have no action during that time.

Connected with the framework K of the machine is a hinged, sliding, or other rod L, projecting on either side and having a trailing arm M for scoring a line along the ground at the required distance from the machine, this line forming the mark for the horse to walk upon when returning across the field, thus insuring regularity of rows of holes with the proper distance between them. The trailing arm may be kept taut by a chain.

In action the horse attached to the shafts of the apparatus pulls same over the field, and in so doing the dibbers will make holes in the ground of the desired depth, into each of which hole is placed a potato or a cabbage plant or other seed or plant by machine or by the laborers or women who follow the apparatus, and the holes are filled up by the feet of the sowers as they pass along, thus insuring rapidity of work, or the holes can all be made and the seeds or plants planted at leisure, or a slight dressing of chemical or other manure may be applied to each hole before sowing or planting.

Any number of wheels may be employed and the distances between each varied, as also the number of dibbers on each wheel.

The sleeves I may be of any length to suit the number of wheels employed, and such sleeves are preferably gripped by the clips P to the bracket Q, attached to the framework of the apparatus, so that when it is desired to change the position of the wheels all that is necessary is to release the clips P and lift the framework, when the axle and wheels can be removed and adjusted as required.

When the apparatus is being transported, I place the outside wheels removed from the axle upon the framework, as at Fig. 8.

In making holes for some kinds of seeds or plants it is necessary that such holes be close together. In that case I use a smaller dibber and fix them in two rows around the periphery of the wheel, as seen in Figs. 4 and 5.

What I claim, and desire to secure by Letters Patent, is—

1. In a dibbing-machine, a frame, an axle carried thereby, a series of wheels mounted on said axle and having their periphery ribbed, a series of hollow dibbers provided with grooves

to permit of the fitting thereof to the ribs of the wheels, bolts for securing the dibbers to the wheels, and sleeves for distancing the wheels mounted upon said axle.

5 2. In a dibbing-machine, a frame, brackets carried thereby, an axle, clips secured to the axle for connecting the latter to the brackets, a series of wheels mounted on said axle and having their periphery ribbed, a series of hollow dibbers connected to the ribs of the wheels, sleeves for distancing the wheels

mounted upon said axle, a rod pivoted to the frame, and a trailing arm connected to said rod.

In testimony whereof I have hereunto set 15 my hand in presence of two subscribing witnesses.

JOHN HALL.

Witnesses:

E. TURTON,
WM. PHELPS.