

March 28, 1933.

O. D. JENNINGS ET AL

1,903,048

COIN CONTROLLED DEVICE

Filed Feb. 20, 1931

3 Sheets-Sheet 1

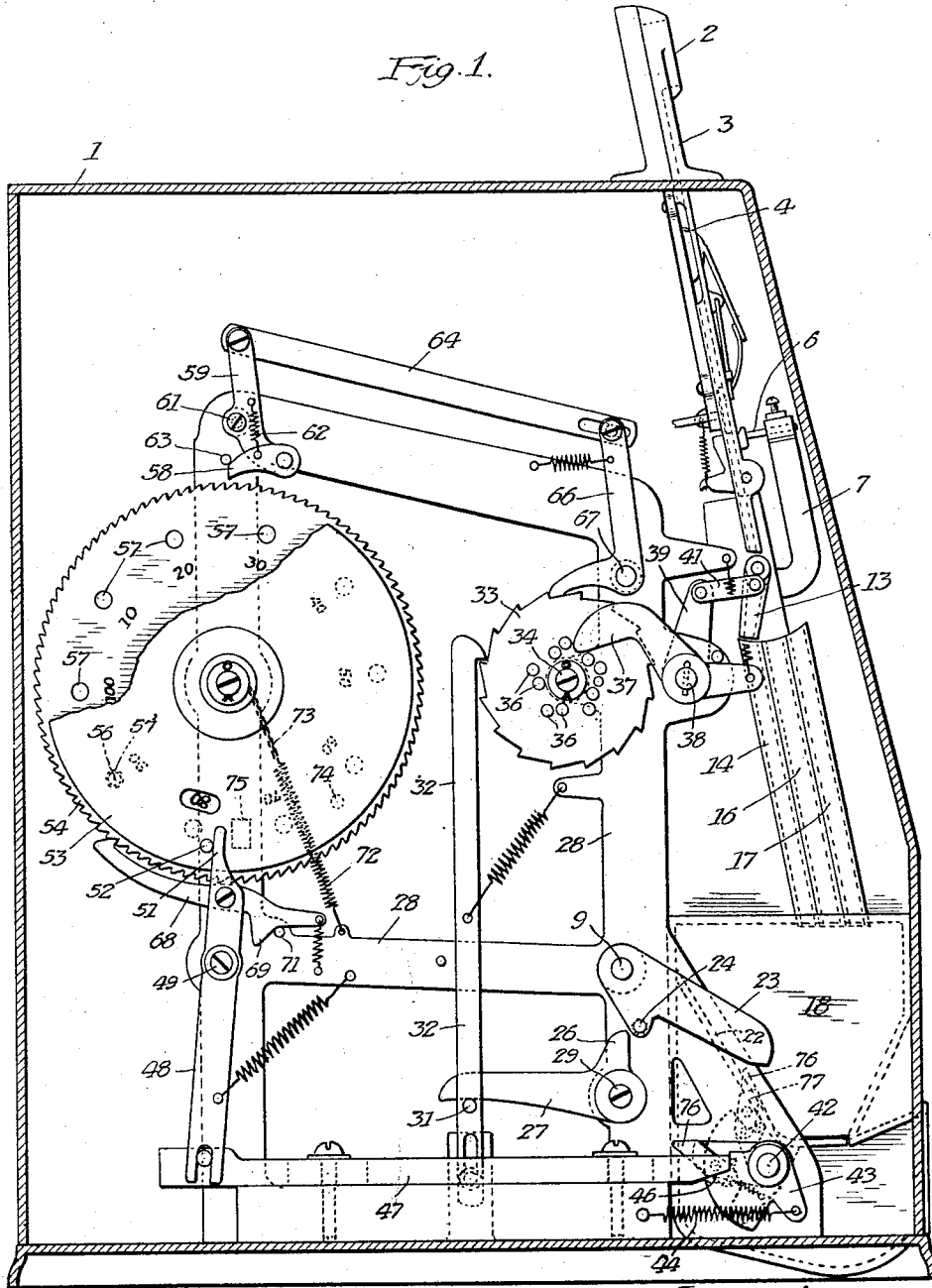

Witness
A. B. Davison.

Inventor
Ode D. Jennings and
Emery Mihalek
By Wilson, Dowell, McCanna & Rehm
Attys.

March 28, 1933.

O. D. JENNINGS ET AL

1,903,048

COIN CONTROLLED DEVICE

Filed Feb. 20, 1931

3 Sheets-Sheet 2

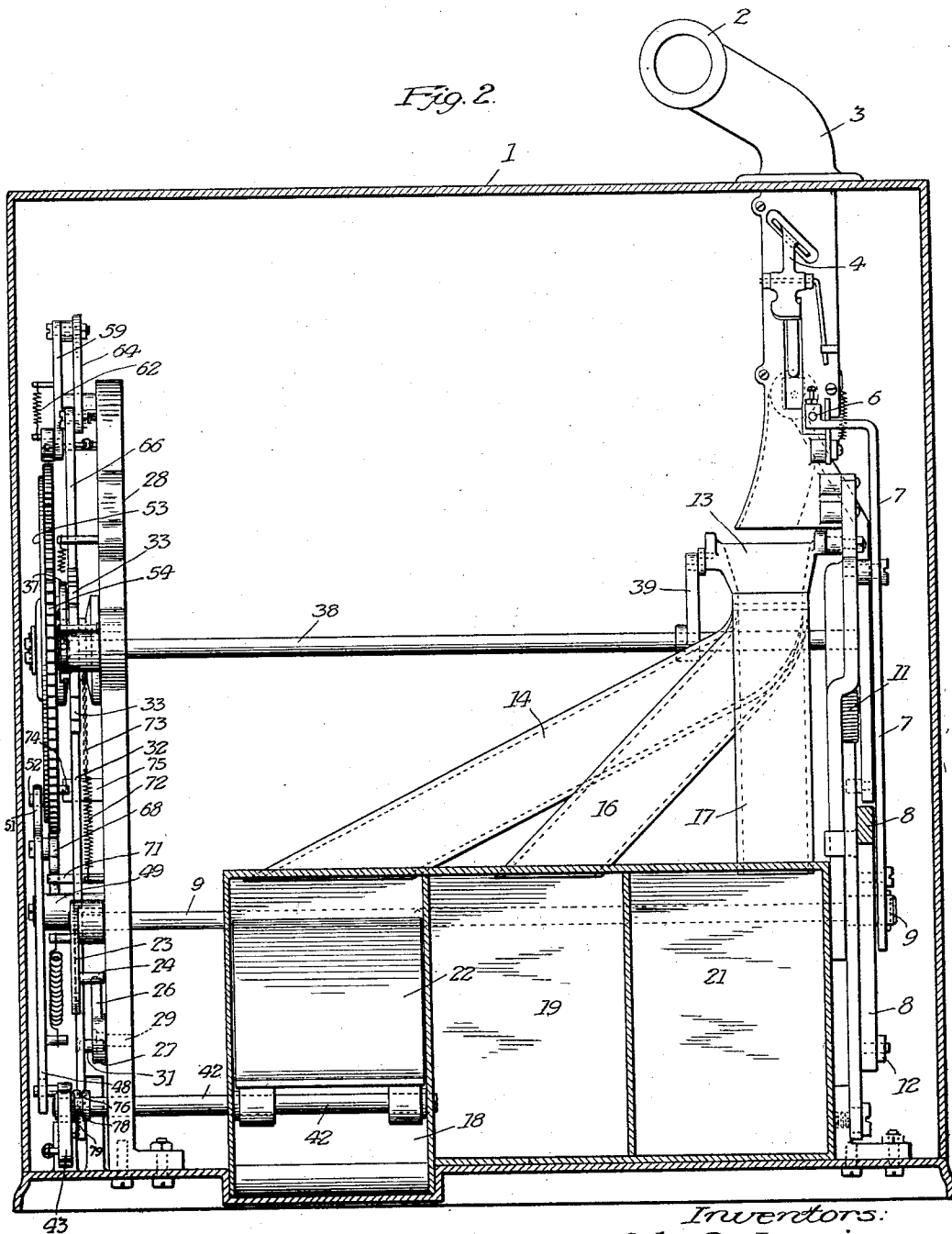

Witness
R.B. Davison.

Inventors:
Ode D. Jennings and
Emery Michalek
By Nelson, Lowell, McLean & Rehm
Attys.

March 28, 1933.

O. D. JENNINGS ET AL

1,903,048

COIN CONTROLLED DEVICE

Filed Feb. 20, 1931

3 Sheets-Sheet 3

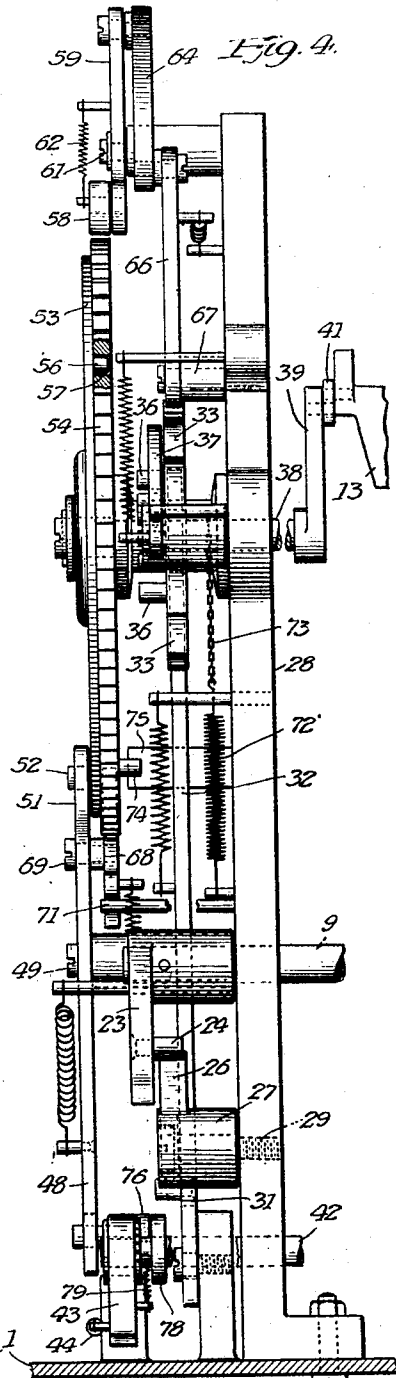
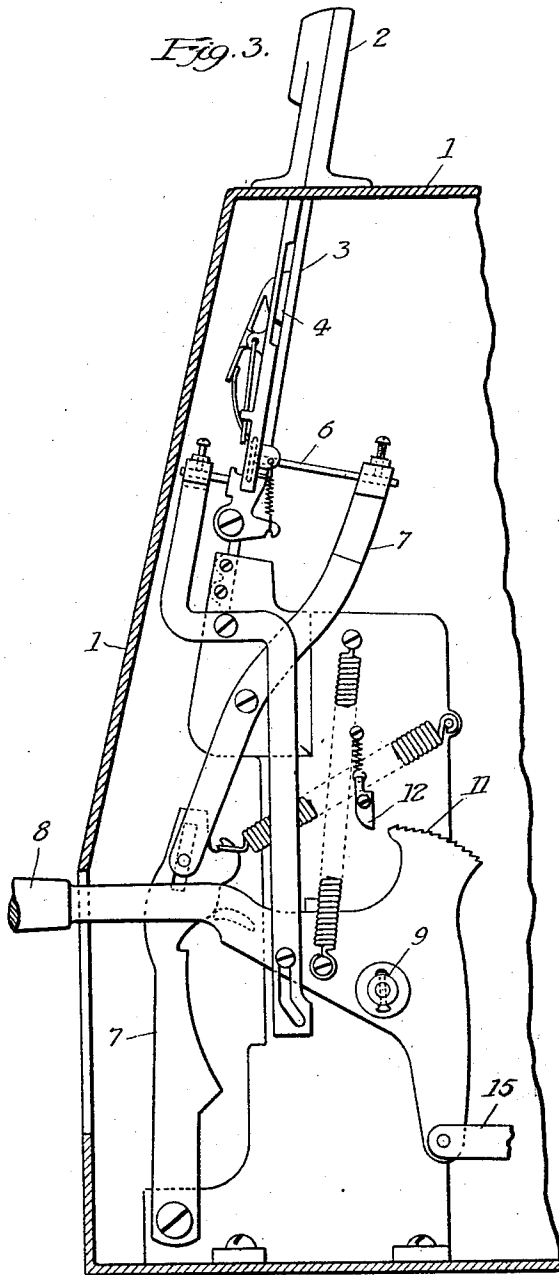

Witness
A. B. Davison

Inventors:
*Ode D. Jennings and
 Emery Mihalek*
 By *Wilson, Dowell, McCune & Rehm*
Attys

UNITED STATES PATENT OFFICE

ODE D. JENNINGS, OF PALATINE, AND EMERY MIHALEK, OF CHICAGO, ILLINOIS, ASSIGNORS TO O. D. JENNINGS & COMPANY, OF CHICAGO, ILLINOIS, A CORPORATION OF ILLINOIS

COIN CONTROLLED DEVICE

Application filed February 20, 1931. Serial No. 517,289.

This invention relates to coin controlled devices and the purpose thereof is to provide means in a device of this character for distributing the coins received into separate groups in a predetermined manner.

In the operation of the coin controlled devices it has heretofore been a difficult problem to satisfactorily divide the coins received where division has been desirable, as for instance where the devices are operatively associated with vending machines for vending merchandise involving the financial interest of two or more parties. For instance, coin controlled vending machines are often installed in premises not owned by the owner of the machine. In such installations the owner of the machine, the owner of the premises upon which the machine is located, the dealer having the responsibility of supplying the machine with merchandise, and possibly a third party servicing the machine may all be interested in the receipts of the machine. In such cases it is obvious that there is a dire need for a coin distributing mechanism which will divide the coins received in accordance with established percentages.

Furthermore, where the element of chance is involved in the operation of the machine along with the distribution of unadvertised or new merchandise, it may be desirable to return a certain percent of the coin receipts to the operator of the machine to stimulate the trade and thus further advertise the merchandise. In such cases it is also desirable to be able to regulate the percentage returned. In such mechanism the coin controlling mechanism is usually constructed to return the operator a fixed percentage upon the last operation of a predetermined number of operations.

In accordance with this invention the foregoing desired features are obtained by providing a movable, preferably pivoted, hopper arranged to receive coins from the coin chute and distribute them to a plurality of receptacles arranged to receive coins from the hopper. The actuating mechanism for the hopper is so arranged and constructed that the hopper may deliver to the various

receptacles in any desired order and may divide and distribute the incoming coins in any desired ratio. One of the receptacles may also be provided with an emptying mechanism which will return the coins therein to the operator after a predetermined number of operations of the machine. The emptying mechanism is so arranged that it may be adjusted to vary this number of operations.

From the following description it will be seen that by the combination of these two features the number of returns and the percentage returned as well as the order and ratio of coins distributed to the various receptacles may be controlled and adjusted to meet any desired needs and arrangement.

Other novel features and their results and advantages will be apparent from the following description given in connection with the drawings, in which:

Fig. 1 is an end elevation, with the cover removed, of a coin controlled device embodying the principles of this invention.

Fig. 2 is a front elevation, with the cover removed and certain parts in section, of the machine shown in Fig. 1.

Fig. 3 is a fragmentary end elevation of the actuating handle and associated mechanism for operating the coin control mechanism.

Fig. 4 is an enlarged front elevation of the coin distributing and return actuating mechanism.

Referring for the present more particularly to Figs. 2 and 3 it will be seen that the entire coin distributing and returning mechanism is housed within a casing 1 through the upper end of which projects the coin receiving end 2 of a coin chute 3 having the usual false coin detectors 4 and 6 and cam locking lever 7 which form no part of this invention and will therefore not be described in detail. The mechanism is operated by an operating handle 8 pinned to a shaft 9 which extends across the machine and is provided with a ratchet 11 which engages a pawl 12 to insure full movement of the handle at each operation.

A lever 15 connects shaft 9 to any suitable vending mechanism (not shown).

The coin chute 3 delivers the coins into the upper end of a pivoted hopper 13 the lower free end of which is selectively movable into communication with each of three tracks 14, 16, and 17, leading to receptacles 18, 19, and 21, respectively. Receptacle 18 is provided with a pivoted bottom 22 which when tilted empties the receptacle and returns the coins in this receptacle to the operator of the machine.

Describing the machine by the manner in which it is operated, it will be seen that as handle 8 is pushed downwardly, having been released by a previously inserted coin the usual manner, the downward movement of handle 8 will rock shaft 9 which upon its other end carries an arm 23 from which a pin 24 projects laterally to engage a projecting finger 26 on arm 27 pivoted to the end frame 28 at 29. The engagement of pin 24 with finger 26 will rotate arm 27 counter-clockwise as viewed in Fig. 1, which will cause the main arm portion to engage a pin 31 projecting from a pawl or hook bar 32, the upper end of which engages a ratchet disc 33.

This disc is rotatably mounted on a stud 34 carried by end frame 28. Ratchet disc 33 carries a plurality of projecting pins 36 which engage in apertures in the disc at varying radial distances from the center thereof. These pins are engaged by a cam finger 37 pinned to rock shaft 38 journaled in frame 28. Shaft 38 extends across the machine, its other end being journaled in the other end frame. Intermediate the ends of shaft 38 an arm 39 is secured thereto, the arm being secured to the pivoted hopper 13 by a link 41. Arm 39 will thus swing hopper 13 about its pivot to cause it to deliver into either of the tracks 14, 16, or 17. The position of hopper 13 is thus determined by engagement of cam finger 37 with pins 36 and accordingly the position is determined by the radial distance of pins 36 from the center of ratchet disc 33.

It follows from the foregoing that at each operation of the coin controlled mechanism through handle 8, disc 33 will be rotated one tooth to bring a new pin 36 into engagement with finger 37. Accordingly the pins 36 may be positioned on disc 33 to cause chute 13 to deliver into any desired track 14, 16, or 17. If two successive pins are at equal distances from the center of stud 34 two successive coins will be delivered into the same track. It is obvious that the order of distributing the coins as well as the ratio may be varied by the arrangement of pins 36 on disc 33.

As previously stated, the bottom 22 of receptacle 18 is arranged to empty the receptacle at predetermined periods after a definite number of operations of the coin controlled mechanism. For this purpose the bottom 22 is secured at one edge to a rock shaft 42 one

end of which is journaled in the wall of the receptacle and the other end of which is journaled in and extends through the end frame 28. Upon its outer end shaft 42 carries a latch plate 43 which is constantly urged in clockwise direction, as viewed in Fig. 1, by spring 44 attached to plate 43 which tends to rotate plate 43 and shaft 42 and hold bottom 22 in open position.

Latch plate 43 is provided with a shoulder 46 which is engaged by a horizontal latch bar 47 which maintains latch plate 43 in the position indicated in full lines in Fig. 1 and consequently holds bottom 22 in closed position against the action of spring 44.

Bar 47 is arranged to be withdrawn from latching position by a tripping mechanism comprising a lever 48 pivoted intermediate its ends as at 49 to frame 28. The upper end of lever 48 terminates in a finger 51 adapted to be engaged by a pin 52 projecting outwardly from a disc 53 adjustably secured to one face of a ratchet disc 54. Disc 53 may be secured to ratchet disc 54 in any one of a plurality of positions and for this reason is provided with a pin 56 projecting inwardly from the opposite side of disc 53 in position to enter any one of a plurality of apertures 57 formed in ratchet disc 54. These apertures permit disc 53 to be rotated about disc 54 and to be secured to the latter in any one of the desired adjusted positions for reasons which will later appear.

Ratchet disc 54 is arranged to be rotated in a counter-clockwise direction one tooth for each operation of handle 8. For this purpose a pawl 58 is pivoted to one end of a lever 59, the lever being pivoted intermediate its ends at 61 to the end frame 28. Pawl 58 is urged into disengaged position by a spring 62 but engages a fixed pin 63 so that upon forward movement pawl 58 will be forced downwardly into engagement with the teeth of ratchet disc 54 to rotate disc 54 in a counter-clockwise direction. The upper end of lever 59 is pivotally connected to one end of a link 64 the other end of which is pivotally connected to one arm of a bell crank lever 66 pivoted to the frame at 67. The other arm of bell crank lever 66 engages the periphery of ratchet disc 33 whereby rotation of ratchet disc 33 will swing crank lever 66 about its pivot and exert a pull on lever 59 to rotate the latter in a clockwise direction to force pawl 58 into engagement with ratchet 54 to rotate the latter in a counter-clockwise direction.

Ratchet disc 54 is prevented from rotating in a clockwise direction by a locking pawl 68 pivoted to the upper end of lever 48. Locking pawl 68 is provided with a cam surface 69 arranged to engage a fixed pin 71 upon tripping movement of lever 48 to move pawl 68 out of engagement with disc 54. This will release ratchet disc 54 after bottom 22 has been moved to open position and

permit disc 54 to be returned to its normal beginning position by a spring 72 connected to chain 73 encircling the hub of disc 54. The normal position is determined by engagement of a pin 74 projecting from disc 54 with a stop 75.

From the foregoing it will be seen that upon each operation of handle 8 and consequent rotation of ratchet 33, ratchet 54 will also be rotated one tooth. After the predetermined and set number of movements of ratchet disc 54 pin 52 will engage finger 51 of lever 48 to pull bar 47 out of engagement with plate 43 to permit opening movement of bottom 22 under influence of spring 44. The movement of lever 48 will also cause the cam surface 69 of locking pawl 68 to ride up upon pin 71 to release ratchet 54 and permit the latter to be returned to normal position.

The bottom 22 of receptacle 18 is returned to closed position by engagement of the end of arm 23 with the projecting end 76 of a pivoted dog 77 secured to arm 78 pinned to shaft 42. Dog 77 is resiliently maintained in projected position by a spring 79 which permits the dog to yield upon the return movements of arm 23 to permit the latter to pass over dog 77.

It will follow from the foregoing description that upon the succeeding operation of handle 8 following the operation upon which the receptacle 18 was emptied, arm 23 will engage disc 77 and return the bottom 22 into closed position with latch bar 47 engaging latch plate 43.

From the foregoing description it will be apparent that a coin controlled device has been provided in which any desired distribution of the coins received may be made, including means for returning a prescribed proportion of the coins received to the operator of the machine. It is also apparent that provision is made for adjustments in many respects and that the actuating parts have been kept to a minimum in number and maintained simple in design.

It is obvious that many changes may be made in details of construction and design without departing from the spirit and scope of this invention as defined in the claims appended hereto.

We claim:

1. In a coin controlled device, a coin chute, a hopper arranged to receive coins from said chute, a plurality of receptacles arranged to receive coins from said hopper, means for varying the position of said hopper to cause it to deliver coins to each of said receptacles in predetermined order, and means for varying the order of delivery from said hopper, said latter means comprising a wheel arranged to be rotated through a certain arc at each operation of the device, pins projecting from said wheel at varying radial distances from the axis of said wheel, a pivoted

arm engaging said pins and connections from said pivoted arm to said hopper whereby the position of said hopper is controlled by the engagement of said arm with said pins.

2. In a coin controlled device, a coin chute, a receptacle arranged to receive coins from said chute and means for emptying said receptacle after a predetermined number of operations of said device, said means comprising a disc, means for rotating said disc through a certain arc at each operation of the device, a tripping member secured to said disc for rotation therewith, and means carried by said tripping member for causing the emptying of said receptacle, said tripping member being adjustably secured to said disc whereby the time of emptying the receptacle may be varied relatively to the number of operations of the device.

3. In a coin controlled device, a coin chute, a hopper arranged to receive coins from said chute, a plurality of receptacles arranged to receive coins from said hopper, and means for varying the position of said hopper to cause it to deliver coins to each of said receptacles in predetermined order, said latter means comprising a wheel arranged to be rotated through a certain arc at each operation of the device, pins projecting from said wheel at varying radial distances from the axis of said wheel, and a pivoted arm engaging said pins and operatively connected to said hopper to control the position thereof.

4. In a coin controlled vending machine, a coin chute, a receptacle arranged to receive coins from said chute and means for emptying said receptacle after a predetermined number of operations of said machine, said means comprising a ratchet disc, means for rotating said disc a certain number of teeth at each operation of the machine, a tripping disc, means for selectively securing said tripping disc to the ratchet disc in any one of a plurality of positions bearing predetermined relation to the teeth of said ratchet disc, and means carried by said tripping disc for causing said receptacle to be emptied.

5. In a coin controlled vending machine, coin controlled mechanism, an actuating shaft controlled by said mechanism, a plurality of receptacles arranged to receive coins from said mechanism and means for emptying one of said receptacles after a predetermined number of operations of said shaft, said means comprising a disc, means for rotating said disc through a certain arc at each operation of the device, a tripping mechanism secured to said disc for rotation therewith for causing the emptying of said receptacle, and means actuated by said shaft for reclosing said receptacle.

In witness of the foregoing we affix our signatures.

ODE D. JENNINGS.
EMERY MIHALEK.