

July 28, 1964

D. J. O'CONNELL ET AL

3,142,069

CONSTRUCTION MEMBERS FOR SWIMMING POOLS

Filed Dec. 4, 1962

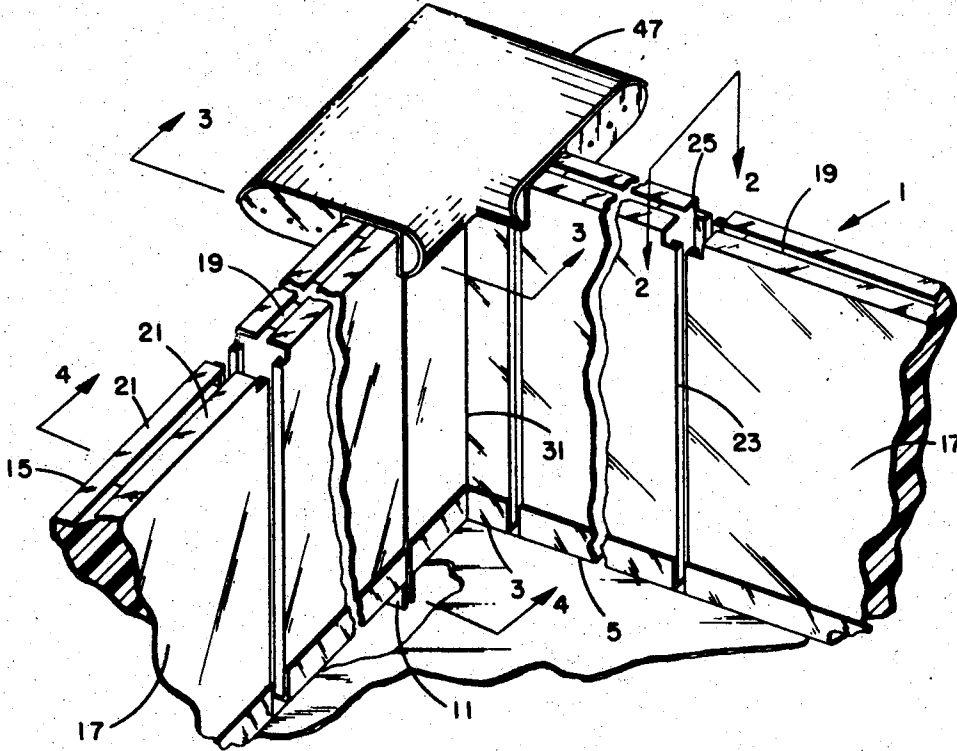

FIG. 1

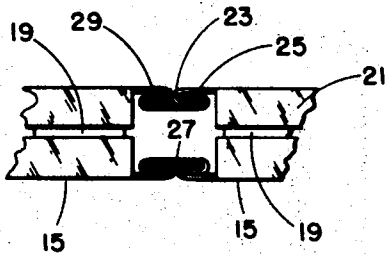

FIG. 2

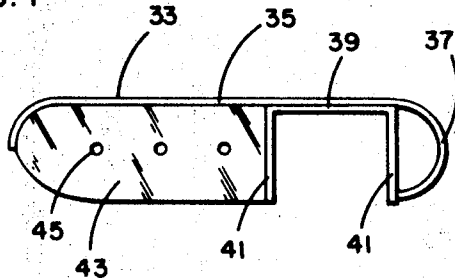

FIG. 3

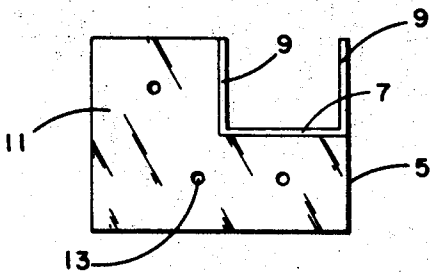

FIG. 4

INVENTORS
DANIEL J. O'CONNELL
PHILIP J. BECKMAN
ROBERT Q. STOCKHOLM

Walter F. Wamsey Jr.
BY Attorney

1

2

3,142,069

CONSTRUCTION MEMBERS FOR SWIMMING POOLS

Daniel J. O'Connell, Waterford, and Philip J. Beckman and Robert Q. Stockholm, Troy, N.Y., assignors to Trojan Pools, Inc., Albany, N.Y., a corporation of New York

Filed Dec. 4, 1962, Ser. No. 242,283
9 Claims. (Cl. 4-172)

This invention relates to construction members utilized in the construction of swimming pools.

The problem in the art is the necessity of construction members that may be utilized in the construction of swimming pool walls whereby the swimming pool walls may be quickly erected at a cost highly competitive with the current market cost of conventional construction of pools. A problem in the art is also the need for construction members that may be utilized to erect and construct swimming pool walls of different sizes and shapes.

Therefore, it is an object of this invention to provide bottom corner channels and bottom channels forming the walls of the swimming pool.

Another object of the invention is to provide channel plates integral with the bottom channels in order that the bottom channels may be bolted together.

A still further object of the invention is to provide corner panels forming the walls of the swimming pool that have outside sheets sandwiching therebetween polystyrene type of bead boards such as known by the trademark "Styrofoam."

Another object of the invention is to provide flanges and inwardly flared lip portions thereof such that the flanges of the panels may be emplaced in abutting relationship and secured by longitudinal panel joiners disposed internally of said panels.

A further object of the invention is to provide corner copings and top coping for emplacement on the top portions of said panels and securement therewith.

Another object of the invention is to provide plates integral with said copings whereby the copings may be bolted together.

These and other objects of the invention should be appreciated from the detailed specification taken in conjunction with the drawing and with reference thereto, wherein like reference numerals refer to similar parts throughout the several views, in which:

FIG. 1 is an isometric view of a corner of the swimming pool showing panels in place ready for assembly;

FIG. 2 is a top plan view of panels assembled, as would appear if taken in the direction 2-2 of FIG. 1;

FIG. 3 is a side elevational view of the top coping taken along the direction 3-3 of FIG. 1;

FIG. 4 is a side elevational view of the bottom channel taken along the direction 4-4 of FIG. 1.

Unless otherwise specified, construction members hereinafter described are made of aluminum or other suitable metal.

FIG. 1 is an isometric view of a corner of the swimming pool showing one of the four corners of the swimming pool and the walls thereof emplaced ready for assembly.

After excavation to the desired and determined outline of the particular swimming pool, the sand or dirt remaining is appropriately compressed.

The next step with which this invention concerns itself is the construction and erection of the walls of the swimming pool. Generally speaking in this connection the walls are formed from panels emplaced in channels forming the skeletal outline of the pool. The channels are secured together appropriately in abutting relationship which imparts structural rigidity to the skeletal frame-

work. After such emplacement of the panels and securement of the panels in abutting relationship the copings are thereon emplaced and secured together and with the panels to complete the upper skeletal framework and impart thereby structural rigidity to the upper skeletal framework as well as to the assembled walls of the pool.

The bottom corner channel 3 is emplaced with bottom channels 5 emplaced end to end in abutting relationship therewith and with each other. The bottom channel 5 has a main web 7 with leg flanges 9 upstanding from each terminal end portion of web 7. A channel plate 11 with holes 13 provided therein, as shown, is suitably secured at each end of channel 5.

The bottom corner channel 3 comprises two channels 5 arranged normal to each other and thereat suitably secured such as by welding.

The holes 13 are utilized to bolt the plates 11 together in the assembly of same.

Emplaced in abutting relationship with the main webs 7 and flanges 9 of the channels are panels 15. Each panel 15 comprises two outside sheets 17 of suitable material such as aluminum with a polystyrene type of plastic bead board 19 sandwiched between the sheets 17 bonded to the interior thereof. The top and bottom of each sheet has an intumed flange 21. The bottom intumed flange (not shown) of each sheet 17 rests upon and abuts main web 7 of the bottom channel.

Disposed at each lateral end portion of sheet 17 is a flange 23 configured into inwardly flared lip portion 25, as shown. In the assembly of the panels, the flanges 23 are arranged to be disposed in abutting relationship with one another.

A panel joiner 27 of similar dimension longitudinally as the height of the panel has intumed lip portions 29 that in assembly engage the inwardly flared lip portion 25 and thereby provides securement of same therewith, as shown more discernably in FIG. 2.

It should be appreciated that the corner panel 31 comprises two panels 15 arranged normal to each other and thereat suitably secured such as by welding.

Disposed at the top of each panel 15 is a top coping 33 having a top rail 35 arcuately configured at one end and arcuately configured at the other end in the form of the nose cove 37. Suitably secured to the underside of top rail 35 is a main web 39 with leg flanges 41 depending from the terminal portions of main web 39. The end of nose cove 37 is suitably secured to the end of one of the leg flanges 41, as shown. Secured at each end of the top coping 33 and to the underside of the top rail 35 and to the other one of the leg flanges 41 is a plate 43 with holes 45 therein provided as shown.

Each top coping 33 dimensionally is of the same length as the panels 15 and bottom channels 5.

The corner coping 47 comprises two top copings 33 arranged normal to each other and thereat suitably secured such as by welding.

The copings are emplaced on the panels with the main web 39 of each coping in abutting relationship with the top intumed flange 21 of each sheet 17 and with each of the flanges 41 engaging the sheets 17, as shown.

The copings are suitably coated with plastic such as by dipping or otherwise, and when the copings are emplaced on the panels an interference fit of the copings with the panels results to achieve a tight fit. The plastic coating on the copings also serve to prevent corrosion of same and to act as a shock absorber upon lateral movement of the panels.

The holes 45 disposed in the plates 43 are utilized to bolt plates 43 together in the assembly of same.

After disposition and assembly of the four walls of the swimming pool, all that need be done is to emplace a plastic liner inside. The liner, of course, as well as the

3

particular emplacement of same within the swimming pool forms no part of this invention.

It should be appreciated however that the panels may be made of different dimensions to afford the particular size swimming pool desired.

It is also within the concept of this invention to provide channels, panels and copings of such appropriate configurations to allow and permit thereby the formation of kidney-shaped, heart-shaped swimming pools, etc.

In this connection, the bottom corner channels may be formed as an arc with the corner panels and corner copings similarly configured; and the bottom channels may be formed as an arc or of different configurations with the panels and copings similarly configured. Of course the means utilized to secure these elements together, as heretofore described, will remain substantially the same.

Having described our invention, we claim:

1. Construction members for the construction and erection of the walls of the swimming pool comprising bottom corner channels, bottom channels, corner panels, panels, longitudinal panel joiners, corner copings and top copings; said bottom corner channels and bottom channels having integral channel plates for securing same together, said channels having main webs and upstanding flanges to receive said corner panels and panels, respectively, forming thereby the walls of said swimming pool; said panels having outside sheets sandwiching therebetween polystyrene type of plastic bead boards, each outside sheet of each of said panels having an inturned flange at the top and bottom portion thereof with the lateral portions of each outside sheet formed as flanges with inwardly flared lip portions; in assembly of said panels to form the walls of the swimming pool the lateral portions of adjacently disposed sheets having their flanges in abutting relationship; said longitudinal panel joiners having inturned lip portions for disposition internally of adjacent sheets and securing together of same by engagement of the inturned lip portions of said panel joiners with the inwardly flared lip portions of said outside sheet; said corner copings and top copings having main webs and depending leg flanges for emplacement on the panels and in abutting relationship with the inturned flanges at the top of said sheets, said copings having integral plates for securing same together.

2. The subject matter as claimed in claim 1, wherein

4

said bottom corner channels comprise bottom channels arranged normal to each other and thereat suitably secured together.

3. The subject matter as claimed in claim 1, wherein each bottom channel has a main web with leg flanges upstanding from each terminal end portion of said web.

4. The subject matter as claimed in claim 1, wherein each channel has a channel plate provided at each end thereof with holes provided therein to permit plates of adjacently disposed channels to be bolted together.

5. The subject matter as claimed in claim 1, wherein said corner panels comprise two panels arranged normal to each other and thereat suitably secured together.

6. The subject matter as claimed in claim 1, wherein said corner copings comprise two top copings arranged normal to each other and thereat suitably secured together.

7. The subject matter as claimed in claim 1, wherein each top coping has a top rail arcuately configured at one end and at the other end arcuately configured in the form of the nose cove.

8. The subject matter as claimed in claim 1, wherein at each end of the top coping is a plate secured to the top rail and to one of said flanges with holes provided therein to permit plates of adjacently disposed copings to be bolted together.

9. The subject matter as claimed in claim 1, wherein said copings are coated with a suitable plastic such that when said copings are emplaced on said panels an interference fit is achieved thereby and with said plastic coating also functioning as a shock absorber upon lateral movement of said panels.

References Cited in the file of this patent

UNITED STATES PATENTS

1,634,947	Lachaine	July 5, 1927
1,825,022	Summers	Sept. 29, 1931
2,127,111	Gaenzle	Aug. 16, 1938
2,576,296	Green	Nov. 27, 1951
2,787,812	Long	Apr. 9, 1957
2,864,098	Lorimer	Dec. 16, 1958
2,869,140	Wiedemann	Jan. 20, 1959
2,869,336	Smidl et al.	Jan. 20, 1959