



(86) Date de dépôt PCT/PCT Filing Date: 2002/09/13
 (87) Date publication PCT/PCT Publication Date: 2003/03/27
 (85) Entrée phase nationale/National Entry: 2004/03/11
 (86) N° demande PCT/PCT Application No.: US 2002/029239
 (87) N° publication PCT/PCT Publication No.: 2003/024357
 (30) Priorités/Priorities: 2001/09/14 (60/322,160) US;
 2002/04/09 (60/371,290) US

(51) Cl.Int.⁷/Int.Cl.⁷ A61F 2/00, A61K 9/58, A61K 9/48,
 A61F 13/00, A61K 9/127, A61K 9/00
 (71) Demandeurs/Applicants:
 MARTIN, FRANCIS J., US;
 BOIARSKI, ANTHONY A., US
 (72) Inventeurs/Inventors:
 MARTIN, FRANCIS J., US;
 BOIARSKI, ANTHONY A., US
 (74) Agent: RIDOUT & MAYBEE LLP

(54) Titre : DISPOSITIF NANOPOREUX MICROFABRIQUE POUR LA LIBERATION PROLONGEE D'UN AGENT
 THERAPEUTIQUE

(54) Title: MICROFABRICATED NANOPORE DEVICE FOR SUSTAINED RELEASE OF THERAPEUTIC AGENT

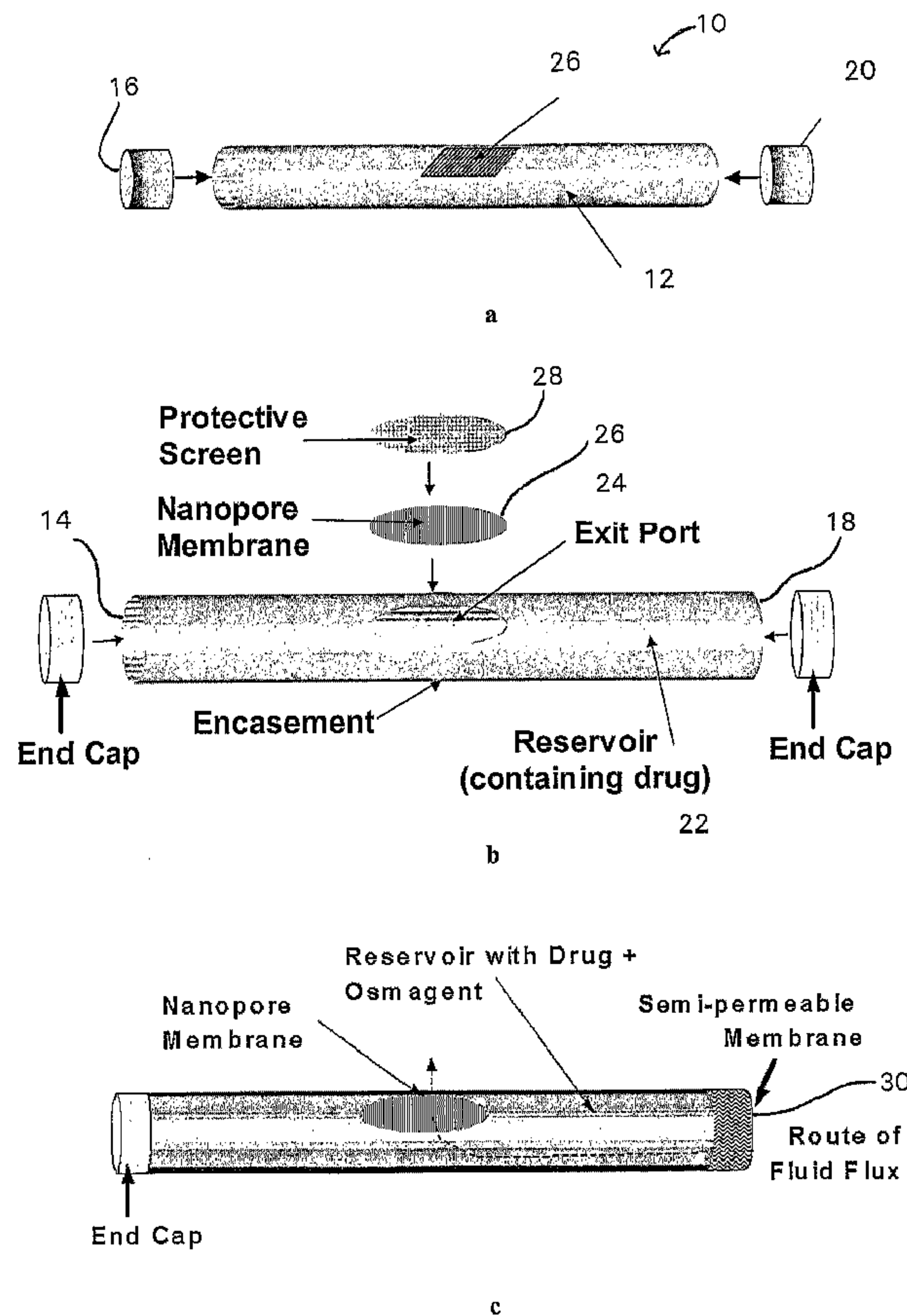

(57) Abrégé/Abstract:

A drug delivery device that includes a capsule for implantation into the body ; the capsule further includes a reservoir for containing a substance such as a therapeutic agent, at least one port for allowing the substance to diffuse from or otherwise exit

(57) **Abrégé(suite)/Abstract(continued):**

the reservoir, and a nanopore membrane in communication with the capsule at or near the exit port for controlling the rate of diffusion of the substance from the exit port. The device also includes an optional screen for providing structural stability to the nanopore membrane and for keeping the pores of the nanopore membrane clear. One embodiment of the drug delivery device includes an osmotic engine internal to the device for creating fluid flow through the device.

(12) INTERNATIONAL APPLICATION PUBLISHED UNDER THE PATENT COOPERATION TREATY (PCT)

(19) World Intellectual Property Organization
International Bureau(43) International Publication Date
27 March 2003 (27.03.2003)

PCT

(10) International Publication Number
WO 03/024357 A3

- (51) International Patent Classification⁷: A61F 2/00, 13/00, A61K 9/00, 9/48, 9/58, 9/127
- (21) International Application Number: PCT/US02/29239
- (22) International Filing Date:
13 September 2002 (13.09.2002)
- (25) Filing Language: English
- (26) Publication Language: English
- (30) Priority Data:
60/322,160 14 September 2001 (14.09.2001) US
60/371,290 9 April 2002 (09.04.2002) US
- (81) Designated States (*national*): AE, AG, AL, AM, AT, AU, AZ, BA, BB, BG, BR, BY, BZ, CA, CH, CN, CO, CR, CU, CZ, DE, DK, DM, DZ, EC, EE, ES, FI, GB, GD, GE, GH, GM, HR, HU, ID, IL, IN, IS, JP, KE, KG, KP, KR, KZ, LC, LK, LR, LS, LT, LU, LV, MA, MD, MG, MK, MN, MW, MX, MZ, NO, NZ, OM, PH, PL, PT, RO, RU, SD, SE, SG, SI, SK, SL, TJ, TM, TN, TR, TT, TZ, UA, UG, UZ, VN, YU, ZA, ZM, ZW.
- (84) Designated States (*regional*): ARIPO patent (GH, GM, KE, LS, MW, MZ, SD, SL, SZ, TZ, UG, ZM, ZW), Eurasian patent (AM, AZ, BY, KG, KZ, MD, RU, TJ, TM), European patent (AT, BE, BG, CH, CY, CZ, DE, DK, EE, ES, FI, FR, GB, GR, IE, IT, LU, MC, NL, PT, SE, SK, TR), OAPI patent (BF, BJ, CF, CG, CI, CM, GA, GN, GQ, GW, ML, MR, NE, SN, TD, TG).

(71) Applicants and
(72) Inventors: MARTIN, Francis, J. [US/US]; 160 San Fernando Way, San Francisco, CA 94127 (US). BOIARSKI, Anthony, A. [US/US]; 3494 Scioto Run Blvd., Hilliard, OH 43026 (US).

Published:
— with international search report

(88) Date of publication of the international search report:
20 November 2003

(74) Agent: MILLER, Courtney, J.; Caffee, Halter & Griswold LLP, 1100 Fifth Third Center, 21 East State Street, Columbus, OH 43215 (US).

For two-letter codes and other abbreviations, refer to the "Guidance Notes on Codes and Abbreviations" appearing at the beginning of each regular issue of the PCT Gazette.

(54) Title: MICROFABRICATED NANOPORE DEVICE FOR SUSTAINED RELEASE OF THERAPEUTIC AGENT

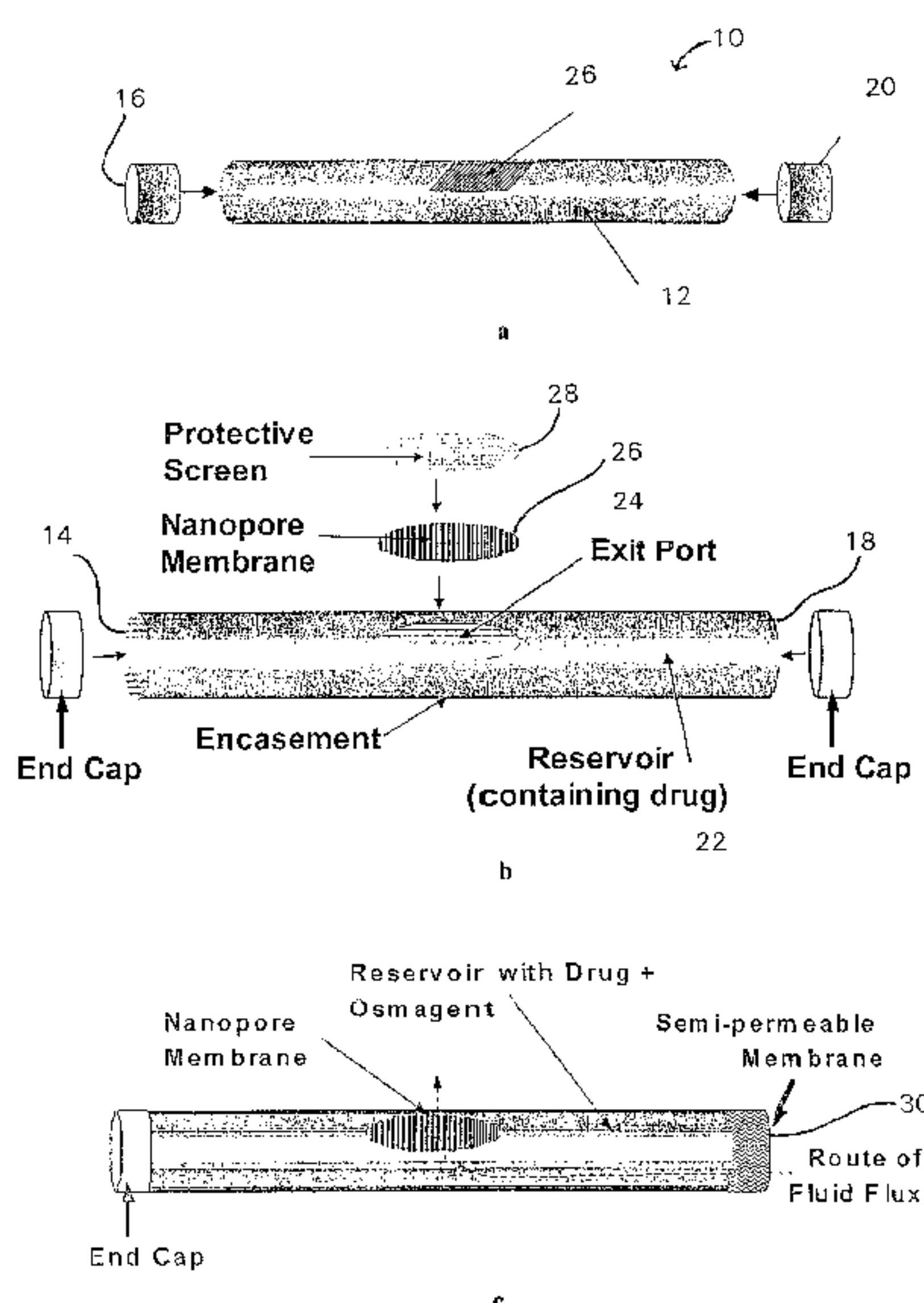

(57) Abstract: A drug delivery device that includes a capsule for implantation into the body; the capsule further includes a reservoir for containing a substance such as a therapeutic agent, at least one port for allowing the substance to diffuse from or otherwise exit the reservoir, and a nanopore membrane in communication with the capsule at or near the exit port for controlling the rate of diffusion of the substance from the exit port. The device also includes an optional screen for providing structural stability to the nanopore membrane and for keeping the pores of the nanopore membrane clear. One embodiment of the drug delivery device includes an osmotic engine internal to the device for creating fluid flow through the device.



WO 03/024357 A3

TITLE OF THE INVENTION

15 **MICROFABRICATED NANOPORE DEVICE FOR SUSTAINED RELEASE OF
THERAPEUTIC AGENT**

CROSS-REFERENCE TO RELATED APPLICATIONS

20 This application claims the benefit of U.S. Provisional Application No. 60/322,160
filed on September 14, 2001, entitled "Microfabricated Nanopore Device for Sustained
Release of Therapeutic Agent" and U.S. Provisional Application No. 60/371,290 filed on
April 9, 2002 entitled "Microfabricated Nanopore Device for Sustained Release of
Therapeutic Agent," the disclosures of which are incorporated as if fully rewritten herein.

25

TECHNICAL FIELD OF THE INVENTION

The present invention relates generally to drug delivery devices designed to be
implanted in the body and specifically to an implantable drug delivery device that utilizes a
30 nanopore membrane fabricated to include arrays of channels having precise geometry for
controlling the release of a therapeutic agent into the body.

BACKGROUND OF THE INVENTION

35 The biotechnology industry has created a number of successful biological drugs for
treating chronic medical conditions. Such drugs include including alpha epoetin (Procrit[®],
Epogen[®]) for treatment of chronic anemia associated with cancer chemotherapy, granulocyte
colony stimulating factor (Neupogen[®]) for treatment of neutropenia associated with cancer
chemotherapy; alpha interferon (Intron[®] A, Roferon[®] and Infergen[®]) for treatment of chronic
40 hepatitis; and, beta Interferon (Avonex[®]) for treatment of relapsing multiple sclerosis.

Although these products provide important benefits to patients and generate sales
measured in billions of dollars, these and most other biological drugs have two major
limitations: (i) due to their large molecular weight (e.g., > 10,000 Daltons) and fragility, such

drugs cannot be delivered to the patient by the oral route, and thus, injection is the only method of administration; and (ii) their typically short half-life results in the drugs being quickly cleared from the body, and therefore, they must be administered to the patient frequently (e.g., daily or three times per week).

5

In the hospital setting, intravenous administration is usually a safe and reliable method for administering biological drugs. In medical situations where hospitalization or physician visits are not necessary, patients often self-administer biological drugs by subcutaneous or intramuscular injection several times a week over the course of therapy.

10

However, this type of therapy is generally associated with pain at the site of injection, injection site reactions, infections, and lack of compliance with dosing schedule.

15

Sustained release implants or drug depots provide a potential solution to the medical need for delivering biological drugs for chronic conditions. Sustained release implants have the potential to eliminate compliance as a concern because they provide the physician with the assurance that the drug is being delivered and the patient with the freedom to go about their normal daily activities. Currently, two basic technologies have been developed to address the medical need for sustained release of chronically administered injectable drugs: injectable erodable polymer depots designed to act for several weeks, and implantable devices capable of delivering potent drugs for up to one year. While effective in certain cases, these prior art devices are subject to important limitations.

20

Sustained release depot formulations that employ polymer depots typically exhibit an initial "burst effect" resulting in the release of up to 90% of the encapsulated drug in the first few days after implantation. Following injection of the device, plasma levels quickly peak and then decline to near constant levels. This characteristic of depots makes them unsuitable for sustained release of a drug over time, where a more constant rate of delivery is desired.

25

Other prior art implantable devices utilize a semi-permeable membrane to cause osmotic tablets to slowly swell as they absorb water. The swelling tablets push a piston that forces drug from a reservoir out of a small opening. Such devices are capable of sustained release over longer periods of time; however, the number of drugs that are compatible with such devices is limited due to the construction of the device. Thus, only highly potent drugs such as certain hormones can be successfully used with these prior art devices.

30

Thus, although current technologies provide important advantages over traditional daily injections, a need currently exists for implantable systems that are more flexible with respect to the types, size, stability and solubility properties of drugs themselves, and with respect to the drug delivery patterns achievable using such a device, i.e., avoidance of “burst” effects and achieving a more constant rate of drug delivery.

SUMMARY OF THE INVENTION

These and other limitations of the prior art are overcome by the present invention which provides a drug delivery device that includes a capsule for implantation into the body. This capsule effectively separates the drug or other material that is encapsulated within the device from the environment external to the device. The capsule further includes a reservoir for containing a substance such as a therapeutic agent, at least one port for allowing the substance to diffuse from or otherwise exit the reservoir; and a nanopore membrane in communication with the capsule at or near the exit port for controlling the rate of diffusion of the substance from the exit port. The device also includes a screen for providing structural support to the nanopore membrane and for keeping the pores of the nanopore membrane clear.

The capsule includes a nanopore membrane consisting of an array of parallel channels with precise dimensions typically in the 4 to 100 nm range separating the internal reservoir from the external medium. By precisely tailoring the pores of the membrane to the molecular dimensions of the drug, such nanopore membranes serve to control the diffusion kinetics of the therapeutic agent from the reservoir at a molecular level. Presumably, the rate of diffusion is related to the geometry of the channels which physically constrain the random molecular motion of drug solute molecules in at least one dimension. Thus, the rate of diffusion is slowed and controlled at a nearly constant level as a function of pore size and is less dependent on the concentration gradient. The device is capable of zero-order release of a therapeutic agent after implantation over prolonged periods (weeks to months, or even years). Controlling the dosage delivered to the patient over time is also possible with the present invention.

One embodiment of the drug delivery device includes an osmotic engine for creating a flow of fluid into and through the device. The osmotic engine further includes a semi-permeable membrane incorporated into a portion of the wall of the capsule, and an

osmotically active agent admixed with the therapeutic agent. The osmotically active agent is of sufficient molecular weight as to be restricted from passing through both the semi-permeable membrane and the nanopore membrane. The osmotic engine also includes a net flux of water entering the reservoir from the external medium through the semi-permeable membrane and exiting the device through the nanopore membrane.

Drugs therapies that meet the following criteria are good candidates for formulation in the present implant device: (i) those that normally injected intravenously or subcutaneously; (ii) those that require frequent administration over a prolonged period of time (e.g., 2-3 times per week for more than two weeks); (iii) those involving treatment of a serious condition where non-compliance to the prescribed treatment regimen will have serious consequences; (iv) those utilizing sufficiently potent drugs so that the cumulative dose for the period of treatment can fit within a small reservoir; and/or (v) those using a drug with adequate stability to withstand exposure to body temperature for duration of therapy.

Further advantages of the present invention will become apparent to those of ordinary skill in the art upon reading and understanding the following detailed description of the preferred embodiments.

BRIEF DESCRIPTION OF THE DRAWINGS

The accompanying drawings and figures, which are incorporated in and form a part of the specification, schematically illustrate preferred embodiments of the invention and, together with the general description given above and detailed description of the preferred embodiments and examples given below, serve to explain the principles of the invention.

FIG. 1 is a graphic representation of the basic steps in the microfabrication of the nanopore membrane of the present invention.

FIG. 2 is a graphic illustration of the basic structural features of the nanopore membrane; both a top view and a side view are presented.

FIG. 3a is a graphic illustration of one embodiment of the drug delivery device of the present invention showing a capsule comprising a segment of thin-walled titanium alloy tubing, sealed at each end with polymer end-caps, and a nanopore membrane fixed to a milled out portion of the capsule.

FIG. 3b is a graphic illustration of another embodiment of the drug delivery device of the present invention providing an exploded view of the device and its component parts.

FIG. 3c is a graphic illustration of another embodiment of the drug delivery device of the present invention including a diffusion-facilitating osmotic engine. This embodiment includes a semipermeable membrane and osmagent, which combine to provide passage of water from the external medium, through the reservoir of the device and out the nanopore membrane channel array (indicated by the dotted line).

FIG. 4 is a graph showing the relative rates of glucose diffusion through nanopore membranes with pore widths ranging from 7 nm to 27 nm.

FIG. 5 plots the rates of glucose diffusion through nanopore membranes of sizes 7 nm, 13 nm and 49 nm, as a function of initial glucose concentration.

FIG. 6 is a graph showing the cumulative release of ^{125}I -labeled albumin from two devices similar to the one illustrated in FIG 3a. The devices are outfitted with nanopore membranes of two pore widths, 26 nm and 13 nm. The dashed lines represent the diffusion rates that are predicted from Fick's laws of diffusion.

FIG. 7 is a plot showing blood levels of ^{125}I -albumin in groups of rats given either a subcutaneous injection of 125 micrograms of ^{125}I -labeled albumin (squares), or implanted with nanopore membrane drug delivery devices designed to release the albumin at rates of 7 $\mu\text{g}/\text{day}$ (circles) and 15 $\mu\text{g}/\text{day}$ (triangles).

FIG. 8 shows the in vitro diffusion of ^{125}I -labeled lysozyme as a function of time through nanopore membranes with pore widths of 7 nm (diamonds), 13 nm (squares) and 49 nm (triangles).

FIG. 9 is graph showing the blood levels over a 50-day period of ^{125}I -labeled lysozyme in groups of rats after subcutaneous injection of 80 μg of lysozyme (dashed line) or after subcutaneous implantation of a nanopore membrane device designed to release 17 $\mu\text{g}/\text{day}$ of lysozyme.

DETAILED DESCRIPTION OF THE INVENTION

I. Drug Delivery Implant Device

5 The present invention is designed as a small medical implant for sustained, constant release of potent drugs used to treat chronic conditions. An exemplary embodiment is substantially cylindrical in shape and has a diameter of about 4 to 8 millimeters (about 0.125 to 0.25 inches) and a length of about 40 to 80 millimeters (about 1.5 to 3 inches). Preferrably, the device is implanted in a manner similar to other medical implants; following
10 administration of a local anesthetic, a physician or other medical professional makes a small (about 5 millimeter) incision in the skin of the upper arm, forearm or abdomen of the patient. Using a sterile implanting tool, the physician inserts the device under the skin of the patient (i.e., subcutaneously) and then covers the incision with a bandage. At the end of the treatment period, the physician removes the implant using a similar procedure.

15 The drug release device of the present invention is designed to slowly release the encapsulated drug at a nearly constant rate to mimic a slow infusion, so that the patient will have therapeutic levels of the drug in his/her body for the entire course of therapy. The drug reservoir of device contains a highly concentrated form of the drug either as a saturated
20 solution, dry powder or concentrated suspension to minimize the size of the device required to hold the cumulative dose required for an extended period of treatment (e.g., several weeks to 6 months).

As shown in FIGS. 3a-c, an exemplary embodiment of the present invention provides
25 a drug delivery device **10** which includes an encasement or capsule **12** for implantation into the body. Capsule **12** further includes reservoir **22** for containing a substance, such as a therapeutic agent, and at least one port **24** for allowing the substance to diffuse from or otherwise exit the reservoir, and a nanopore membrane **26** attached to, mounted on, or otherwise in communication with capsule **12** and exit port **24** for controlling the rate of
30 diffusion of the substance from exit port **24**. In this embodiment, membrane **26** serves as the only diffusion-limiting communication between the reservoir and the external medium.

Optionally, the drug delivery device may include a screen **28** for providing structural
stability to the nanopore membrane without affecting the rate of release of a therapeutic
35 agent. This screen is typically made from a porous polymer or other material and may

completely or partially surround the capsule, or may be positioned on top of the membrane, on the bottom of the membrane, or both on the top and bottom of the membrane. Screen **28** also prevents fouling/blockage or cellular infiltration of the pores of nanopore membrane **26**. In one embodiment the entire capsule is coating with a porous polymeric material to protect
5 the device and provide a biocompatible interface.

An exemplary embodiment of the capsule of the drug delivery device of the present invention is an impermeable, non-deformable, biocompatible capsule which further includes a first open end **14**; a second open end **18**; a first polymeric end cap **16** for closing first open
10 end **14**; and a polymeric second end cap **20** for closing second open end **18**. The open ends are useful for filling reservoir **22** with a therapeutic agent or other substance. In one embodiment, the end caps are tapered such that when attached to each open end of the capsule, both ends of the capsule are bullet-shaped. Capsule **12** may be substantially cylindrical in cross-section or substantially elliptical in cross-section. A semi-triangular anti-
15 rotation device may be attached to each end of the capsule, or anywhere along the length of the capsule, for preventing side-to-side rotation of the capsule following implantation of the drug delivery device. Capsule **12** may be manufactured from titanium alloy, surgical grade stainless steel, or a polymeric material.

20 The drug delivery device of the present invention is designed for implantation in the body subcutaneously, in a defined anatomical compartment of the body, at a pathological site, or at combination of sites. Suitable sites include the peritoneal cavity, brain, plural cavity, surgical site, pathological site, pericardium, inter articular space, eye, and/or subarachnoid space (CSF).

25 In an exemplary embodiment, capsule **12** is typically made of segments of standard thin-walled stainless steel or titanium alloy tubing in which a flat area has been milled to serve as the seat for nanopore membrane **26**. Nanopore membrane **26** is mounted over this area of the device under protective screen **28**. In one embodiment, drug delivery device **10** is
30 about 4 to 10 mm in diameter and about 45-100 mm in length with an internal volume of approximately about 250 μL to several milliliters depending on the thickness of the tubing.

In another embodiment, a small area of the capsule wall includes openings (pores or slits) with dimensions too large to restrict diffusion of even the largest molecules. These

openings serve as non-diffusion-limiting exit ports within the capsule wall and protect internal components of device **10**. In this embodiment, nanopore membrane **26** is seated next to or near an opening in the wall of a tubular inset, the outer diameter of which is similar to the inner diameter of the capsule. The inset tube segment is inserted into the interior space of the capsule and the nanopore membrane array is positioned beneath the openings. The inset tube is configured with o-rings, which serve to seal the space between the capsule openings and the surface of the nanopore membrane. As with the embodiment detailed above, nanopore membrane **26** again serves as the only constraint to free passage into the reservoir filled with the therapeutic agent from the environment outside of or external to the capsule.

10

As stated, drug delivery device **10** is designed to contain a volume of therapeutic agent or other substance in reservoir **22**. In an exemplary embodiment, the capacity of the drug reservoir is approximately 500 μL . The therapeutic agent may be present in a variety of forms including, but not limited to, an aqueous solution, an aqueous crystalline suspension (slurry), a micronized suspension. These solutions or suspensions may be formed within reservoir **22** immediately before implantation of device **10** by hydration of a dry form of the therapeutic agent, or by hydration after implantation of device **10** by inflow of a biological fluid from the medium surrounding the device.

20

Suitable therapeutic agents include biologically active macromolecules such as peptides, protein drugs, or a polynucleic acids. Suitable peptides or protein biopharmaceuticals include: hormones, hormone agonists, hormone antagonists, growth factors such as CSF, EPO, and growth hormone, cytokines such as the interleukins, immune modulators such as interferon gamma and interferon beta, anti-infectives such as interferon alpha 2b, anti-inflammatories, immune suppressant/anti-rejection drugs, antibodies, anti-arthritic drugs, and anti-tumor agents. Suitable polynucleic acids include: DNA, RNA, plasmid molecules, antisense DNA, and ribozymes. Small molecular weight molecules are also compatible with the present invention. Suitable small molecular weight molecules include, but are not limited to, pain medications or anti-psychotic agents.

30

In an exemplary embodiment, drug formulations are filled into device **10** as a liquid solution; however, if necessary more highly concentrated forms including a slurry consisting of an insoluble drug suspension, dry powders or centrifuged pellets may be used. For certain unstable drugs, such as certain proteins and peptides, the drug may be co-formulated with a

bulking agent such as lactose and loaded into the reservoir of the device as a liquid. After loading the drug/lactose solution may be freeze-dried in situ, providing a dry storage form for the drug within the device reservoir. Excipients may be added to improve drug loading such as polymers, ion-exchange beads, affinity matrices, cyclodextrins, surfactants and the like.
5 Co-solvents such as ethanol and DMSO may also be employed for the purpose of loading additional drug.

Preferably, stabilizers co-formulated with therapeutic agent contained within reservoir comprise water miscible solvents, or polymers of sufficiently high molecular weight and/or
10 shape as to be retained within capsule reservoir because they cannot pass out through nanopore membrane 26. Suitable stabilizers include, but are not limited to carbohydrates, dextrans, polyvinyl pyrrolidone, gum arabic, polyethylene glycol, albumin, dendritic polymers, cross-linked polymer matrix, and surfactants.

15 II. Nanopore Membrane

Prior art nanopore membrane designs (referred to as the "Berkeley" design) include arrays of C-shaped annular, or rectangular channels with precise dimensions which in their smallest aspect, are in the 4-100 nm range. C-shaped annular pores which are approximately
20 9 μm in circumference with 2 μm anchor regions result in a low porosity (0.26 %) for a typical 25 nm pore membrane. The minimum reported pore size produced by the Berkeley design was 18 nm. In the original Berkeley design, the pores were produced in a 1.4 by 3.4 mm area (4.76 mm^2) within a 6 by 8 mm, rectangular-shaped solid silicon die region. U.S. Patents 5,651,900, 5,770,076 and 5,849,486 disclose microfabrication techniques compatible
25 with the present invention and are hereby incorporated by reference in their entirety.

One aspect of the present invention is based on the unexpected finding that such membranes can be tailored to control the rate of release of drugs from an implantable device. By precisely fabricating pores with dimensions that are selected to range from a size similar
30 to that of the drug molecule to several times the size of the drug, (e.g., approximating 1 to 5 times the Stoke's diameter of a drug molecule), nanopore membranes can be used to control diffusion at a molecular level by providing release kinetics which approach zero-order. Zero-order refers to a rate of diffusion that does not change as the concentration gradient decays. To achieve suitably sized pores, the nanopore membrane includes a microfabricated array of

parallel channels, wherein the smallest aspect of the channels is selected to provide a constant rate of release of the drug or other substance.

The exemplary embodiment of the present invention was created using the basic
5 microfabrication approach pioneered at Berkeley. However, as shown in FIGS. 1 and 2, the
exemplary embodiment includes a novel parallel-pore design. This pore design comprises a
series of parallel, rectangular-shaped, 45 μm long channels that are separated lengthwise by
10 μm anchor regions (FIG. 2). The width of these rectangular channels is typically selected
at fixed values in the 2 to 100 nm range. Using a 2 μm pore spacing in the width direction, a
10 high membrane porosity of 1% is achieved for the same 25 nm pore size. Pore sizes down to
4 nm have been produced by this approach. The die layout is also changed relative to the
Berkeley design. A similar large-die design is produced with 6 by 8 mm overall dimensions,
but the pore area is increased to 2 by 3.5 mm (7 mm^2). A smaller membrane die is also
produced. In this case, the membrane area is 1 by 2 mm (2 mm^2) within a 3 by 4 mm solid
15 die area.

For the purposes of the present invention, microfabrication facilities available at The
Case Western Reserve University (CWRU) in Cleveland, Ohio were used to produce several
batches of the new nanopore membrane design. This procedure uses a combination of
20 photolithography and deposition/selective removal of sacrificial layers. The pore size itself is
determined by the deposition and selective removal of a sacrificial layer (silicon dioxide)
sandwiched between two silicon structural members as in Fig 3. Using this approach, a
selected array of parallel membrane pores, with a specific pore size, density, and path length
parameter, is fabricated as desired.

25 The method for fabricating nanometer-sized (nanometer wide and 45 μm long)
channels consists of three basic steps: (1) surface micromachining of the nanochannels in a
thin film on the top of a silicon wafer by depositing a nanometer-thick sacrificial oxide layer
between two silicon structures; (2) forming the membrane by etching away the bulk of the
30 silicon wafer underneath the thin-film structure, and (3) etching the sacrificial layer to form
nanometer-sized pores in the membrane. Silicon, poly silicon, a combination of silicon
materials, polymer, and co-polymer are all useful for fabricating the nanopore membrane
using the techniques described.

The first major process step (see FIG. 1) involves photo or plasma-etching continuous channels in the silicon substrate over its entire surface to define the overall pore shape **100**. The etched channels are typically 2 μm wide separated by 2 μm and the depth of these channels defines the membrane thickness of 5 μm . After forming the channels, the next major step involves growing a sacrificial thermal oxide layer over the entire wafer surface including the surface area of the channels **101**. The oxide layer thickness defines the pore size in the final membrane. Precise control is needed at this step to assure a uniform, known pore size. Thermal oxidation gives pore size (width) control with sub-nanometer resolution across the entire 4-inch silicon wafer. Etching away the thermal oxide in selected areas of the channel forms anchor regions. The distance between these anchor regions defines the pore height (45 μm).

A polysilicon structural layer is then deposited over the channels **102** and planarized to allow access to the nanopore channels from the front face of the array **103**. Following a boron-doping step to create a KOH etch stop **105**, a silicon nitride protective layer is deposited and windows are opened in this layer on the backside of the wafer **104**. The bulk silicon is removed through these etch windows up to the etch stop layer of the array using KOH **106**. This bulk etch defines the membrane area and dye shape. The structure is then released by etching the protective nitride layers and the sacrificial oxide layers in a concentrated HF bath **107**.

The major structural component of the nanopore membranes created by this approach is illustrated diagrammatically in FIG. 2. An array of parallel rectangular channels is formed **201** between alternating silicon **200** and polysilicon **202** structural layers following the removal of the sacrificial oxide layer. Anchor regions **203** which lie between the channel arrays provide mechanical strength.

Two batches of membranes were fabricated for the present invention. Table 1 provides a list of the number of membrane dies produced. In this table, the batch number is listed along with the number of both large and small dies produced with a given pore size. In all cases, the pore depth is 4.5 μm . Note that both large and small-sized dies were produced and that these membranes have a variety of pore sizes in the 2 to 100 nm range.

Table 1. Nanopore Membrane Dies

Batch Number	Nominal Pore Size, nm	Number of Dies	
		Small	Large
2	4	121	53
1	7	391	263
1	13	340	268
1	20	92	69
1	27	116	79
1	47	72	24
1	49	187	136

Other embodiments of the nanopore membrane of the present invention incorporate the following characteristics, which presumably improve or enhance the durability of the membrane: (i) a multi-directional pore pattern rather than orienting all the pores parallel in only one direction which tends to increase stress; (ii) reduced membrane area; (iii) incorporation of membrane material that is stronger than silicon such as silicon carbide; and (iv) the additional of a hexagonal honeycomb support structure to the surface of the membrane that increases its effective thickness without changing the pore length membrane thickness.

III. Osmotic Engine

Release of a therapeutic agent from the drug delivery device of the present invention is based on a constrained diffusion mechanism. That is, the rate of diffusion of the therapeutic agent through a static aqueous phase filling the channels of the nanopore membrane is restricted by the width of the channels. It is possible to facilitate or "boost" diffusion through such channels by providing a net movement or flux of fluid in an outward direction relative to the drug reservoir, through the nanopore channels. Such a fluid flux may be provided by equipping the device with an osmotic engine. Therefore, in an alternate embodiment of the present invention the diffusional release mechanism of drug delivery device 10 is facilitated by incorporation of an osmotic engine into the device described above.

With reference to FIG. 3c, this osmotic engine includes (i) a semi-permeable membrane 30 incorporated into a portion of the wall of the capsule, wherein the membrane is permeable to the passage of fluid present in the environment external to capsule 12 and substantially impermeable to the passage of the therapeutic agent in reservoir 22; (ii) an osmotically active agent admixed with the therapeutic agent, wherein the osmotically active agent is of sufficient molecular weight as to be restricted from passing through both the semi-

permeable membrane and the nanopore membrane; and (iii) a net flux of water entering the reservoir **22** from the external environment through semi-permeable membrane **30** and exiting through the nanopore membrane.

5 The osmotic engine consists of two basic elements. The first is a semi-permeable membrane introduced into a portion of the containment wall of the capsule. For example, one (or both) of the solid end caps depicted in FIG. 1 may be substituted with a plug made of a semi-permeable material such as cellulose acetate (see FIG. 9). Such a membrane permits entry of fluid from the medium or environment surrounding device **10**, but prevents the
10 release of solutes contained within the reservoir **22**. Listings of suitable semi-permeable membrane materials and permeability-modifying additives are found in U.S. Patents 4,077,407 and 4,874,388, and are available from Eastman Chemical Company (Kingsport, TN). Precast cellulose acetate and other cellulose ester membrane sheet stock are available from Polymer Extruded Products (Newark NJ) and LAM Technologies (Berlin CT).

15 The second component of the osmotic pump is an osmotically active agent, or osmagent, admixed with the therapeutic agent. The osmagent is of sufficient molecular weight as to be restricted from passage through both the semi-permeable membrane and the nanopore membrane and thus is substantially retained within reservoir **22**. The osmagent
20 preferred for biologically labile protein therapeutics comprises a water-miscible, liquid polymer in which a dry, micronized form of the drug is suspended. Thus, the osmagent may be linear or branched water miscible polymers of MW 5000 to several million Daltons, including but not limited to, dextrans, maltodextrins, albumin, starches, polysucrose, Ficoll, dendritic polymers, hyaluronic acid, polyvinyl alcohol, polyethylene oxide-polypropylene
25 oxide copolymers, polyethylene glycol, and polyvinylpyrrolidone. The osmagent may also be fluid polymers up to 50:50 mixture by weight including but not limited to: Pluracol V-10, a member of the UCON lubricant series, a member of the Pluronic surfactant series, or a member of the Tetronic surfactant series.

30 The present invention is intended to release encapsulated drug at physiologic temperatures and over time frames ranging from weeks to months. Some clinically important biologically active protein therapeutics may be unstable in aqueous solution under such conditions. While the therapeutic agent may be formulated as an aqueous or crystalline suspension which may or may not include stabilizers such as those described above, a

preferred osmotic engine design for biologically labile protein therapeutics is a dry, micronized form of the drug suspended in the anhydrous, water-miscible, liquid polymer osmagent. A drug used with this embodiment may be micronized by any number of methods known to the art such as spray drying, freeze drying and/or milling. The micronized drug and osmagent are mixed to create a suspension that is filled into the device reservoir. The osmagent may be mixed with a small fraction of water (for example, up to 50:50 by weight) if desired, for example, to change viscosity and/or to prime the system for diffusion-based operation.

The osmagent creates a colloid osmotic pressure within reservoir **22**, attracting water from the external medium. Capsule **12** is not expandable and thus the volume of the reservoir is held constant. Water entering the device through semi-permeable membrane **30** under the influence of the osmagent is thus forced to exit through the nanopore channels. The rate of flux of water is controllable by (i) the features of the semi-permeable membrane including the material used, additives, inherent water permeability, surface area, and thickness, and (ii) the nature of the osmotically active polymer including the molecular weight, concentration, and osmotic pressure. Methods to calculate permeation rates through semi-permeable membranes under selected conditions are disclosed in U.S. Patent 4,077,407 which is hereby incorporated by reference in its entirety.

Fluid flux provided by such an osmotic engine is used to boost efflux of drug molecules from the drug delivery device when necessary to achieve a desired release profile (i.e., zero-order) and/or desired durations of release. The fluid flux is also intended to maintain the patency of the nanopore fluid channels by inhibiting fouling or clogging of the nanopore channel walls and end-openings. The fluid flux also provides a means to slowly dissolve therapeutic agents which have been loaded into the device reservoir in an insoluble, partially soluble or dry form.

In a preferred configuration, following implantation, external fluid enters the device through semi-permeable membrane **30**, under the influence of the water-attracting properties of the polymer osmagent, and exits through the nanopore membrane while the volume of the reservoir remains constant. Entry of water into device **10** slowly solubilizes the exposed surfaces of the micronized drug particles, and small amounts of drug become entrained as a solute in the fluid flow. The amount of water passing through the device at any given time is

limited and thus the protein enters solution gradually over time. Since the dry particles dissolve slowly, the stability of the micronized protein drug is preserved. Release of drug molecules from the device is based on diffusion through the fluid phase and is controlled by water flux through the reservoir, the rate of solvation of the drug into the water phase, and by
5 selection of the proper nanopore membrane dimensions (as detailed below). Combined, these features provide a high degree of control over release kinetics.

The osmotic influx of fluid provided by the osmotic engine feature of the present invention also allows for in vitro or in situ activation of the device. For example, during
10 manufacturing, drug delivery device 10 may be loaded with a dry form of a protein drug-osmagent admixture to preserve biological activity of the protein drug during distribution and storage. At the time of use, the device may be placed in a sterile aqueous solution, such as PBS or D5W, for a period of time sufficient for entry of a portion of the external aqueous medium into the device reservoir through the semi-permeable membrane. The fluid entering
15 the reservoir dissolves or partially dissolves the protein drug and osmagent and primes the nanopore channels with fluid, thus providing the aqueous pathways required for the constrained diffusion mechanism to operate. The device would then be rinsed with sterile PBS or D5W and implanted. Similarly, a device loaded with a partially dissolved or dry therapeutic agent-osmagent admixture may be implanted into a body compartment such as
20 under the skin. The external fluid medium would enter the device reservoir through the semi-permeable membrane, hydrating the drug-osmagent admixture and priming the nanopore channels. A slight delay in drug efflux is expected as priming takes place.

In summary, the combination of the physical constraints imposed on the diffusion of
25 drug molecules provided by the nanopore membrane geometry, plus the osmotically driven flux of fluid through the device, provides a novel means of tailoring the release kinetics of selected drugs to achieve optimal therapeutic outcomes.

30 IV. Examples

Controlling the rate of drug diffusion through nanopore membrane 26 is an important aspect of the present invention. Previous research involving nanopore membranes has not recognized the relationship between nanopore membrane geometry and the phenomenon of constrained molecular diffusion. Furthermore, previous research has not suggested the
35 benefits of combining constrained diffusion with an osmotic engine as detailed above. Thus,

diffusion studies have been conducted for the present invention to evaluate the applicability of nanopore membranes to constrained molecular diffusion for a small molecule (glucose), a large molecule (albumin), and lysozyme. These studies, detailed in the examples below, provide a demonstration of the ability of nanopore membranes to constrain rates of diffusion
5 over a broad range of molecular weights.

Example 1: Glucose Diffusion

Nanopore membranes with channel widths ranging from of 7 nm, to 27 nm were
10 micofabricated from silicon materials according the methods described above. These membranes were placed either in an implant device fitted with nanopore membranes as described above, or placed in a COSART diffusion cell. These diffusion cells consist of two reservoirs with the nanopore membrane sandwiched between. The membrane is sealed by the use of appropriately sized o-rings. The lower reservoir is equipped with inlet and outlet ports
15 through which buffer (such as phosphate buffered saline, PBS) is slowly pumped (using either an HPLC pump or syringe pump). The lower flow cell also contains a stir bar for mixing. A solution of glucose is added to the upper reservoir and fractions of the fluid exiting the lower reservoir collected using a fraction collector or by physically moving the outlet tubing from one empty test tube to another at preset time intervals. The glucose
20 concentration in the fractions is measured using a either a standard glucose monitor or standardized glucose-oxidase assay.

The cumulative diffusion of glucose through nanopore membranes of four different channel widths, 7 nm, 13 nm, 20 nm, and 27 nm is plotted in FIG. 4. The shapes of the curves
25 for the 13 nm, 20 nm, and 27 nm membranes indicates that the cumulative movement (flux) of glucose through the membrane is non-linear, and as a consequence the rate slows relative to the initial rate as the concentration gradient across the membranes decays. The rate of glucose diffusion through the 7 nm membrane, however, is linear or zero-order. This pattern is unexpected since the diffusion gradient is decaying with time and thus the driving force for
30 diffusion would be expected to decay as well.

The glucose diffusion rate (expressed as mg/day) through nanopore membranes of 7 nm, 13 nm, and 49 nm widths as a function of initial glucose concentration is shown in FIG.
5. For the 13 nm and 49 nm membranes, the rates of glucose flux increases with increasing
35 concentration. In the case of the 7 nm membrane, however, a flux rate of 1.2 mg/day is

maintained across a wide range of initial glucose concentrations (i.e., 165-660 mg/mL). These data indicate that glucose diffusion through nanopore membranes with widths of about 7 nm and below is basically zero-order and is not influenced by the magnitude of the concentration gradient across the membrane.

5

Example 2. Albumin Diffusion

For these experiments, Radiolabeled (^{125}I) bovine serum albumin (BSA) was obtained from ICN Biochemicals; Unlabeled BSA was obtained from Sigma Chemical Corp., and
10 microfabricated silicon nanoporous membranes were fabricated as described above.

Implants fitted with nanopore membranes were assembled and loaded with ^{125}I BSA. Implants were sterilized prior to loading by either autoclaving or chemically sterilizing by soaking in a standard phosphate-buffered saline solution (PBS) containing 0.2% (w/v)
15 sodium azide. The implant formulation was generated by diluting the appropriate amount of ^{125}I -labeled BSA (determined from the specific activity reported by the manufacturer for each lot obtained) with a 25 mg per mL stock solution of unlabeled BSA. The solution was filter
sterilized. The final formulation solution contained BSA at a concentration of 5 mg per mL and a ^{125}I -labeled BSA concentration of 60-65 μCi per 300 μL , the current approximate
20 loading capacity of each implant.

After aseptically loading the implants with the BSA formulation, each implant was washed by dipping into 25 mL PBS and transferred to a fresh 25 mL PBS, both contained in sterile 50 mL conical tubes. Any residual air bubbles, trapped in the grate opening above the
25 membrane area, were dislodged by moving a stream of liquid containing PBS over the grating with a 1 mL syringe containing a 27 gauge luer-lock needle. A 100 μL aliquot was removed once a day for 3 to 6 days or until the expected constant rate of diffusion was achieved. The aliquot was transferred to a 5 mL polypropylene serum tube and counted on a Packard Gamma Counter.

30

For each treatment group, three, ten to twelve-week old female Sprague Dawley rats were anesthetized with isoflurane. After shaving and sterilizing the implant site, a 1.5 cm incision was made parallel to and 1 cm from the backbone through the skin layer midway on the animals' flank. A pocket was made for the implant under the skin by opening and closing
35 a pair of hemostats to the front and back of the incision. The incision "pocket" was made in

this way to ensure that the ends of the implant did migrate to a position over the incision, limiting the possibility for the ends of the implant to push out through the incision. The implant was rinsed in 2 changes of PBS; the grate of the implant was wetted with 10 uL of PBS. A small amount (100 μ L) of PBS was introduced into the pockets for wetting purposes
5 and the implants were inserted into the incision pocket and centered under the incision site. The incision was sutured and the animal was allowed to recover.

A small plastic ring was used to orient the implant membrane downward and in the proper direction relative to the animals' flesh and skin. Release in the proper direction
10 insured that the implant diffusion was not impeded in any way by physical blockage.

For pharmacokinetic analysis, blood samples were obtained. Animals were anesthetized with Isoflurane, the tails warmed for 2 minutes, and 0.2 ml samples of blood were collected from the lateral tail veins. The blood was allowed to clot for 45 minutes, and
15 then spun at 10,000 G for 1 minute, and then a 50 μ L aliquot removed for gamma counting on a Packard Gamma Counter.

The results of these in vivo experiments, shown in FIG. 7, represent the total calculated amount of BSA measured in the vascular compartment (in μ g per mL) of each of
20 the three treatment groups (n = 3): subcutaneous injection, or NanoGATE devices designed to deliver 7 μ g/day or 15 μ g/day. In the case of the implant groups, a two-phase pattern is seen for BSA clearance from the blood stream. The first phase, represented by data collected between days 2 through 10, shows a rapidly decreasing slope that closely resembles the slope obtained with a 125 μ g subcutaneous (SubQ) injection. This rapid initial clearance of BSA
25 from the bloodstream is very likely due to the extravasation of BSA from capillary beds into the interstitial fluid compartment and eventually the lymphatic system. Equilibration of exogenously administered BSA between the blood and interstitial compartments is a well known phenomenon.

The second phase of BSA serum levels shown in FIG. 7 is represented by data collected between days 10 through 50. During this phase, BSA is slowly cleared from the animals' blood. These data suggest that physiological equilibrium or steady-state is achieved
30 suggesting that the rate of BSA release from the NanoGATE implant is balanced with

clearance from the blood stream. This pattern stands in stark contrast to the rapid clearance of the one-time, 125 µg bolus dose of BSA administered via subcutaneous injection.

Example 3. Lysozyme Diffusion

5

Lysozyme, an enzyme with a molecular weight intermediate between that of glucose and albumin (MW 12,000 Daltons) was used to measure diffusion kinetics through nanopore membranes both in vitro and in vivo. Radiolabeled (¹²⁵-I) lysozyme was obtained from ICN Biochemicals. Unlabeled lysozyme was obtained from Sigma Chemical Corp. Radiolabeled lysozyme was admixed with unlabeled lysozyme and loaded into implants as described above for albumin. In vitro release rates for three size membranes are plotted in FIG. 8. Lysozyme release rates are zero-order for membranes pore sizes of 13 nm and 49 nm. Release of lysozyme through the 7 nm membrane implant was virtually undetectable over the time frame tested (5 days). Additional in vitro release testing revealed that, like glucose, at a pore size of 13 nm or less, flux of lysozyme through the nanopore membrane is independent of initial concentration (data not shown).

Blood levels of lysozyme in groups of three rats given either a single subcutaneous bolus of 80 µg or after implantation of a nanopore implant device designed to release lysozyme at a rate of 17 µg/day are shown in FIG 9. Lysozyme given subcutaneously is cleared rapidly from the blood stream of the animals with an apparent half-life of less than several days. In contract, blood levels in animals in the implant group were maintained for a period of several months.

25 V. Method of Use

The present invention is useful for delivering a therapeutic agent to the body in a controlled manner, according to the following method. First therapeutic agent is loaded into the device, and then the device is surgically implanted into the patient. As detailed above, an aqueous solution or suspension of the therapeutic agent may be formed in reservoir 22 immediately before implantation by means of hydrating a dry form of the therapeutic agent. An aqueous solution or suspension of the therapeutic agent may also be formed in the reservoir after implantation by introducing a biological fluid derived from the medium surrounding the device into the device.

35

While the drug delivery device **10** is in use, the rate of release of the therapeutic agent is substantially zero-order and is typically independent of the concentration of the therapeutic agent on the interior of the capsule. The rate of release of the therapeutic agent is substantially constant for a period of several weeks to several months following surgical
5 implantation of the device.

While the above description contains many specificities, these should not be construed as limitations on the scope of the invention, but rather as exemplification of preferred embodiments. Numerous other variations of the present invention are possible, and
10 it is not intended herein to mention all of the possible equivalent forms or ramifications of this invention.

CLAIMS

What is claimed:

- 5 1. A drug delivery device comprising:
- (a) a capsule for implantation into the body, wherein said capsule further comprises:
 - (i) a reservoir for containing a substance;
 - (ii) at least one port for allowing said substance to diffuse from or otherwise exit said reservoir; and
 - 10 (b) a nanopore membrane in communication with said capsule for controlling the rate of diffusion of said substance from said at least one exit port.
2. The drug delivery device of claim 1, further comprising a screen for providing structural support to said nanopore membrane, and wherein said screen completely or partially
15 surrounds said capsule, or is positioned on top of said membrane, on the bottom of said membrane, or both on the top and bottom of said membrane.
3. The drug delivery device of claim 1, wherein said device is implanted in the body under the skin, in a defined anatomical compartment of the body, at a pathological site, or a
20 combination thereof.
4. The drug delivery device of claim 1, wherein said capsule is coated with a porous polymeric material for protecting said device and providing a biocompatible interface.
- 25 5. The drug delivery device of claim 1, wherein said capsule is an impermeable, non-deformable, biocompatible capsule further comprising a first open end; a second open end; a first end cap for closing said first open end; and a second end cap for closing said second open end.
- 30 6. The drug delivery device of claim 5, wherein said end caps are tapered such that when attached to each open end of said capsule, both ends of said capsule are bullet-shaped.
7. The drug delivery device of claim 1, wherein said capsule is substantially cylindrical in cross section.

35

8. The drug delivery device of claim 7 further comprising a semi-triangular anti-rotation device attached to each end of said capsule, or anywhere along the length of said capsule, for preventing side-to-side rotation of said capsule following implantation of said drug delivery device.

5

9. The drug delivery device of claim 1, wherein said capsule is substantially elliptical in cross section.

10

10. The drug delivery device of claim 1, wherein said capsule is manufactured from titanium alloy, surgical grade stainless steel, or a polymeric material.

11. The drug delivery device of claim 1, wherein said substance is an aqueous solution or suspension of a therapeutic agent.

15

12. The drug delivery device of claim 11, wherein said therapeutic agent is a biologically active macromolecule is a peptide, a protein drug, or a polynucleic acid.

20

13. The drug delivery device of claim 12, wherein said peptide or protein drug is a growth factor, hormone, anti-infective agent, cytokine, immune-modulator, anti-tumor agent, or hormone antagonist.

14. The drug delivery device of claim 13, wherein said anti-infective agent is interferon alpha 2b.

25

15. The drug delivery device of claim 13, wherein said cytokine is interferon beta.

16. The drug delivery device of claim 11, wherein said therapeutic agent is a small molecular weight molecule.

30

17. The drug delivery device of claim 16, wherein said small molecular weight molecule is a pain medication or an anti-psychotic agent.

35

18. The drug delivery device of claim 1, wherein said nanopore membrane further comprises a microfabricated array of parallel channels, and wherein the smallest aspect of said channels is selected to provide a constant rate of release of said substance.

19. The drug delivery device of claim 18, wherein the smallest aspect of said array of parallel channels is selected to be about 1 to 5 times the molecular dimensions of said substance.

20. The drug delivery device of claim 1, wherein said nanopore membrane is microfabricated
5 from silicon, poly silicon, a combination of silicon materials, polymer, or co-polymer.

21. A drug delivery device comprising:

(a) a capsule for implantation into the body, wherein said capsule further comprises:

(i) a reservoir for containing a therapeutic agent;

10 (ii) at least one port for allowing said therapeutic agent to diffuse from or otherwise exit said reservoir; and

(b) a nanopore membrane in communication with said capsule for controlling the rate of diffusion of said substance from said at least one exit port; and

15 (c) an osmotic engine for affecting the flow of fluid through the device, said osmotic engine further comprising:

(i) a semi-permeable membrane incorporated into a portion of the wall of said capsule, and

20 (ii) an osmotically active agent admixed with said therapeutic agent, wherein said osmotically active agent is of sufficient molecular weight as to be restricted from passing through both said semi-permeable membrane and said nanopore membrane; and

(iii) a net flux of water entering said reservoir through said semi-permeable membrane and exiting said device through said nanopore membrane.

25 22. The drug delivery device of claim 21, wherein said osmotically active agent comprises a water-miscible polymer having a molecular weight sufficiently large to prevent the passage of said agent out of said reservoir through either the semi-permeable membrane or said nanopore membrane.

30 23. The drug delivery device of claim 24, wherein the molecular weight of said polymer is about 5,000 to several million Daltons.

24. The drug delivery device of claim 22, wherein said polymer is selected from the group consisting of Pluracol V-10, the UCON lubricant series, the Pluronic surfactant series, and the Tetronic surfactant series.

5 25. The drug delivery device of claim 24, wherein said polymer is hydrated with water up to a 50/50 mixture by weight.

26. The drug delivery device of claim 22, wherein said therapeutic agent comprises a micronized dry powder suspended within said polymer.

10

27. A method for delivering a therapeutic agent to the body in a controlled manner, said method comprising the steps of:

15 (a) loading said therapeutic agent into a device, said device further comprising: a capsule, wherein said capsule further comprises: a reservoir for containing said therapeutic agent; at least one port for allowing said therapeutic agent to diffuse from or otherwise exit said reservoir; and a nanopore membrane in communication with said capsule for controlling the rate of diffusion of said substance from said at least one exit port, said nanopore membrane further comprising a microfabricated array of parallel channels; and

20 (b) surgically implanting said device subcutaneously or by placement into an anatomical compartment of the body.

25 28. The method of claim 27, further comprising the step of forming an aqueous solution or suspension of said therapeutic agent in said reservoir immediately before implantation by means of hydrating a dry form of said therapeutic agent.

29. The method of claim 27, further comprising the step of forming an aqueous solution or suspension of said therapeutic agent in said reservoir after implantation by introduction into said device of a biological fluid derived from the medium surrounding said device.

30

30. The method of claim 27, wherein the rate of release of said therapeutic agent is substantially zero-order.

31. The method of claim 27, wherein the rate of release of said therapeutic agent is substantially independent of the concentration of said therapeutic agent on the interior of said capsule.
- 5 32. The method of claim 27, wherein the rate of release of said therapeutic agent is substantially constant for a period of several weeks to several months following surgical implantation of said device.

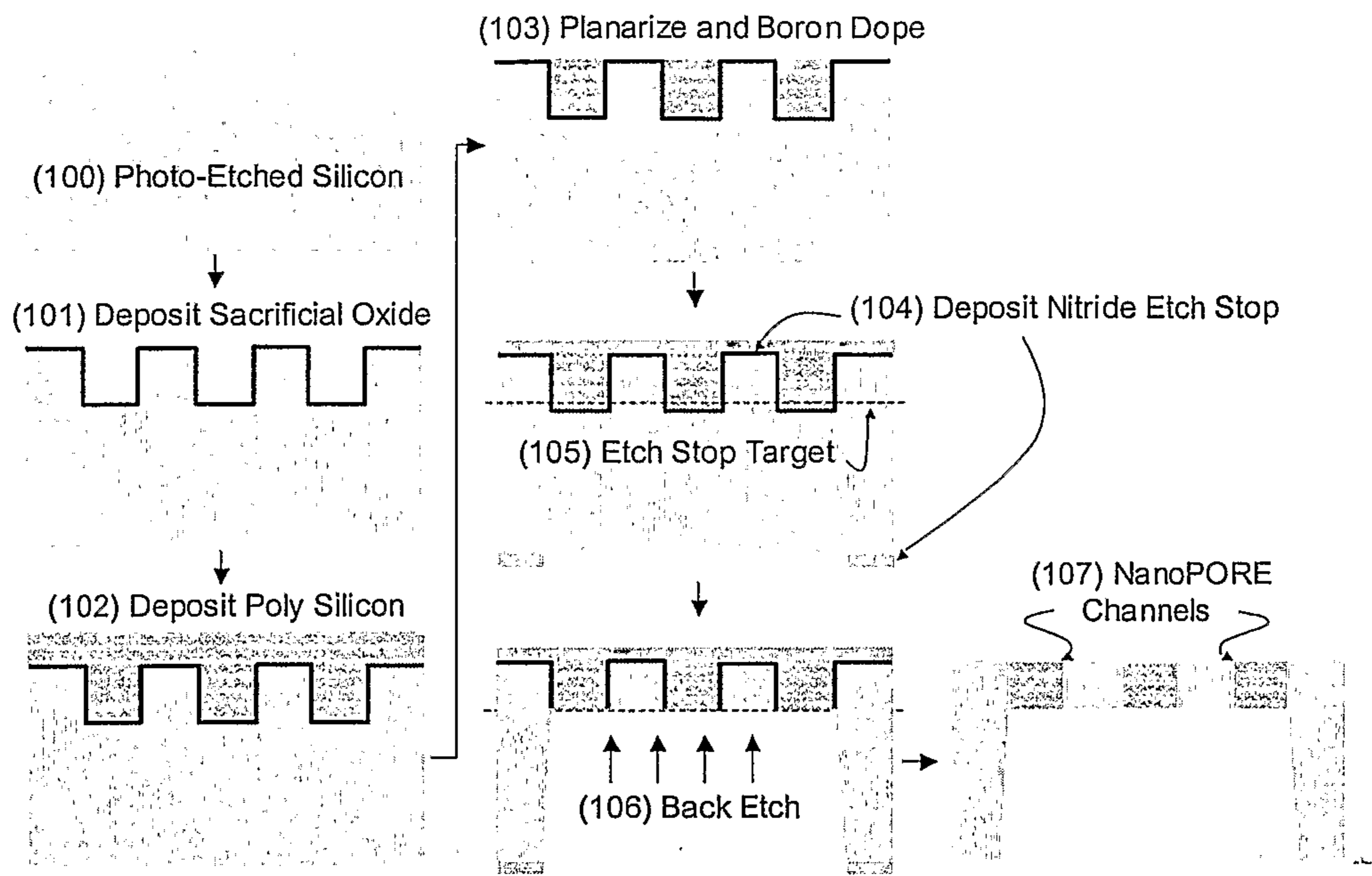

FIG. 1

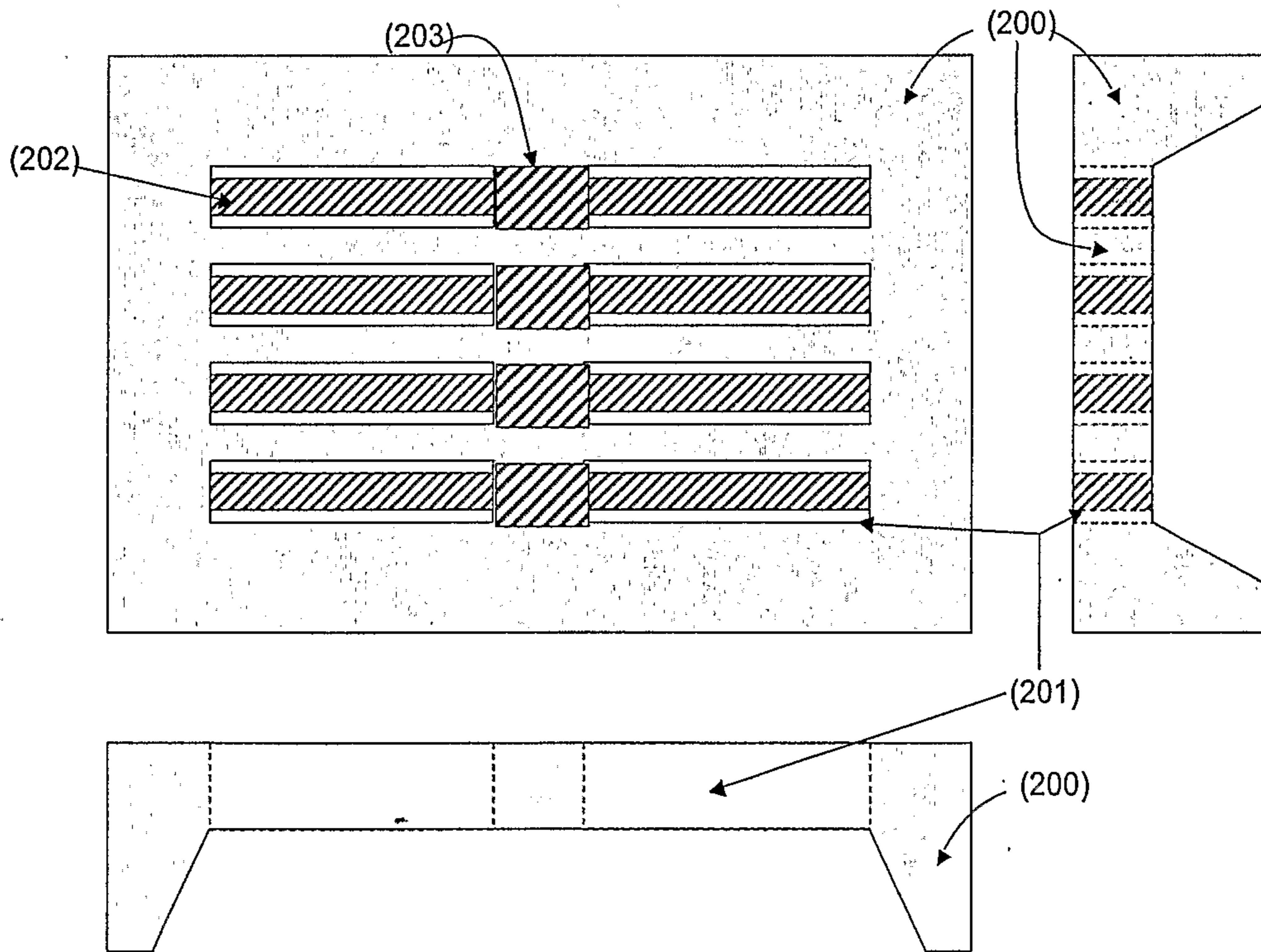

FIG. 2

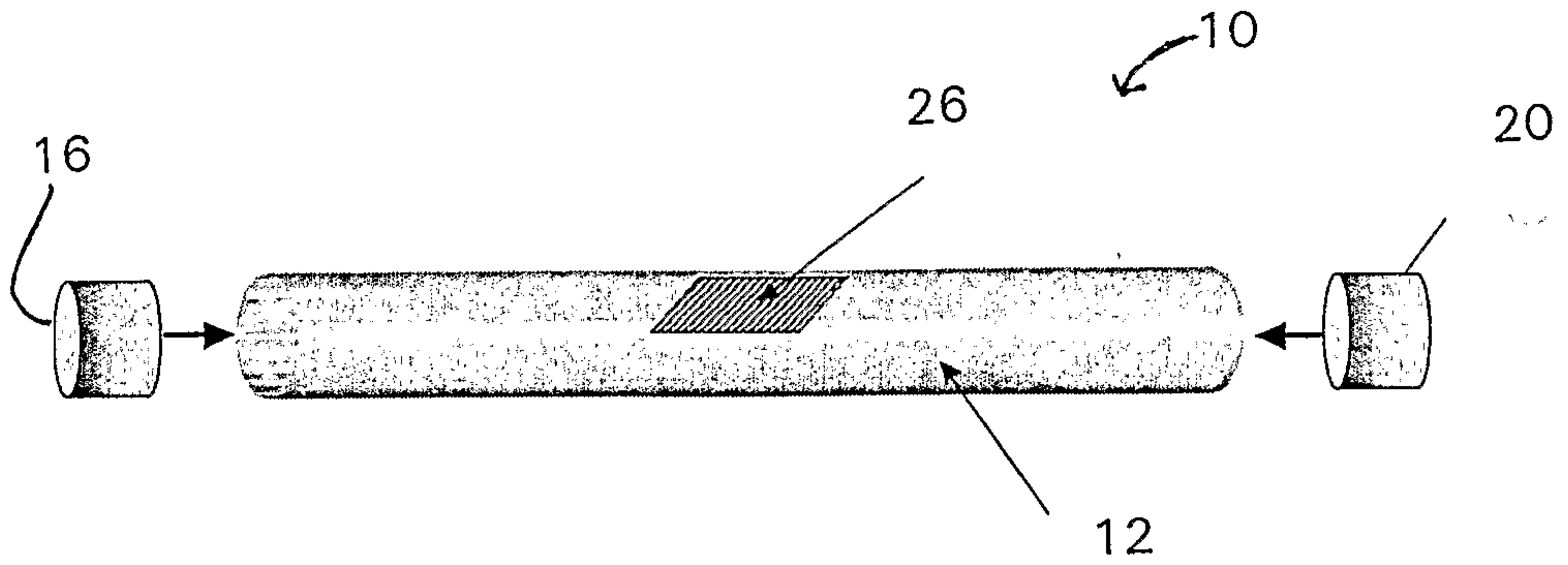

FIG. 3a

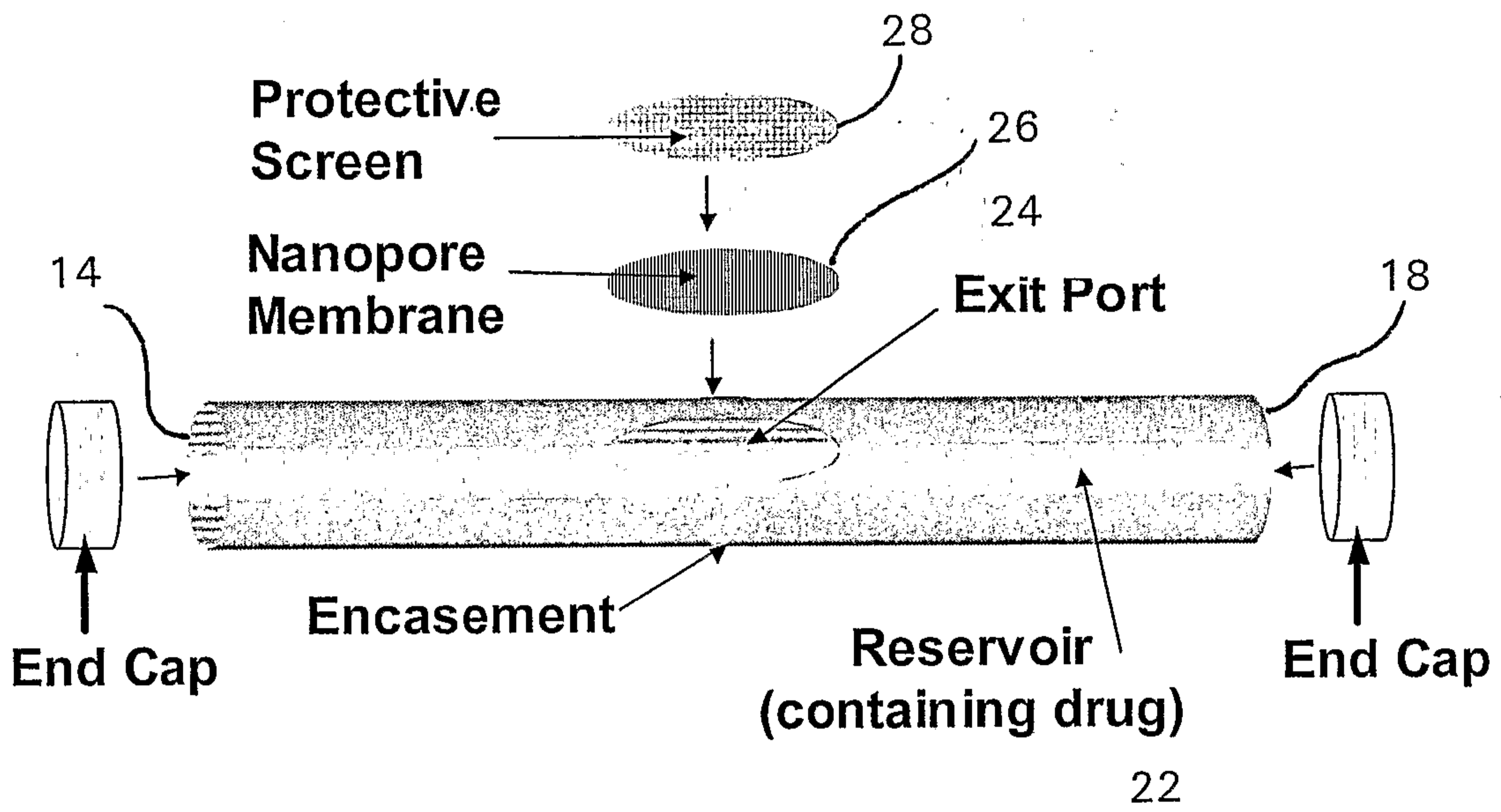

FIG. 3b

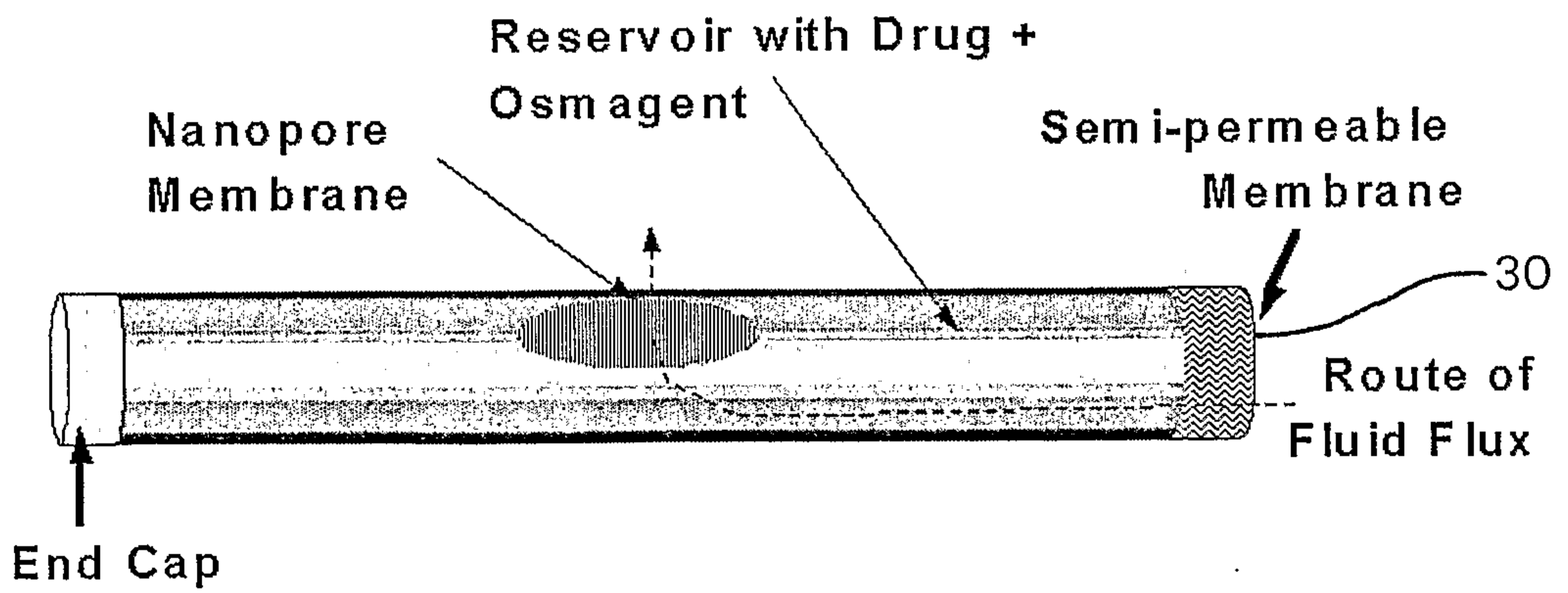

FIG. 3c

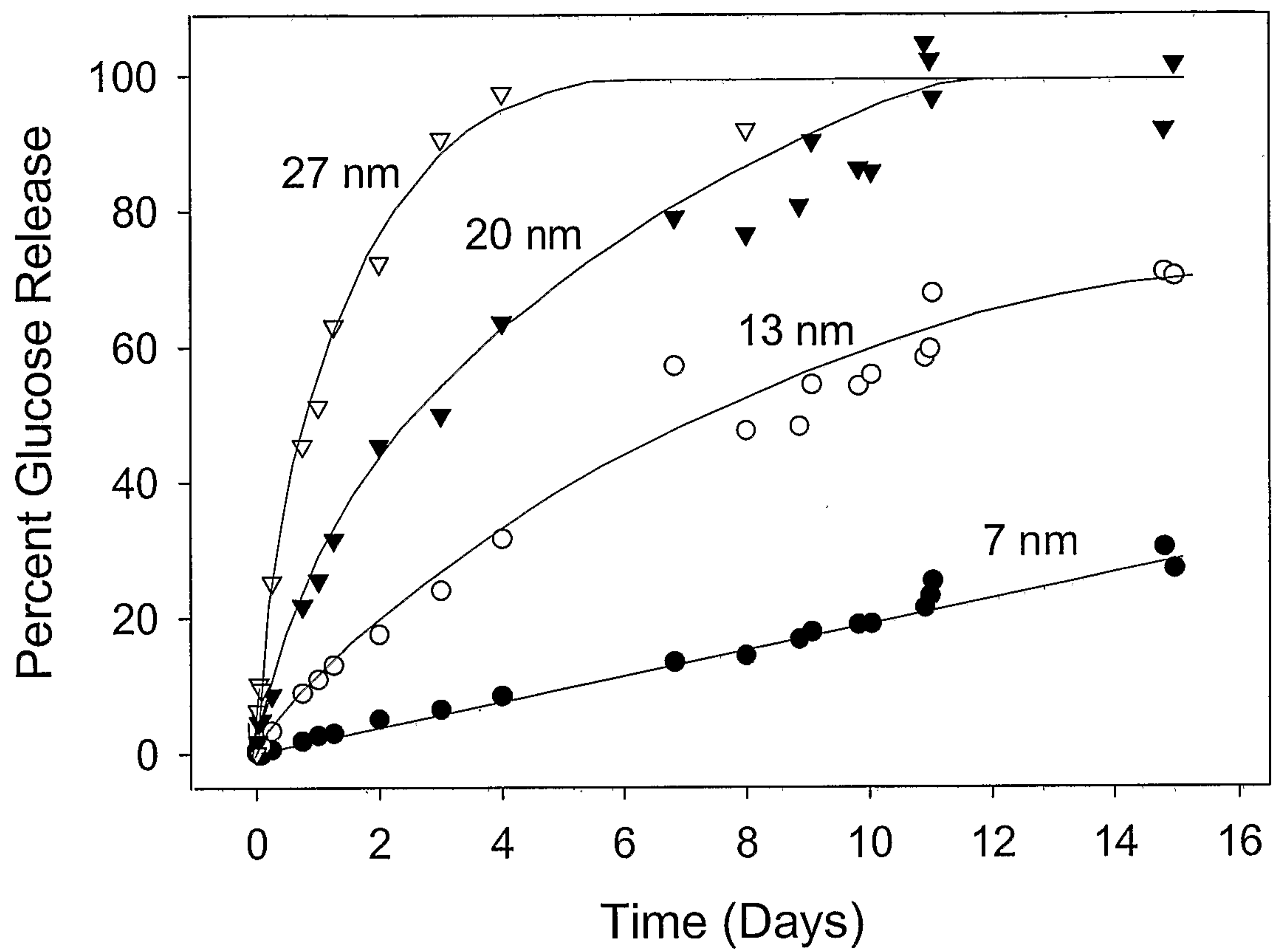

FIG. 4

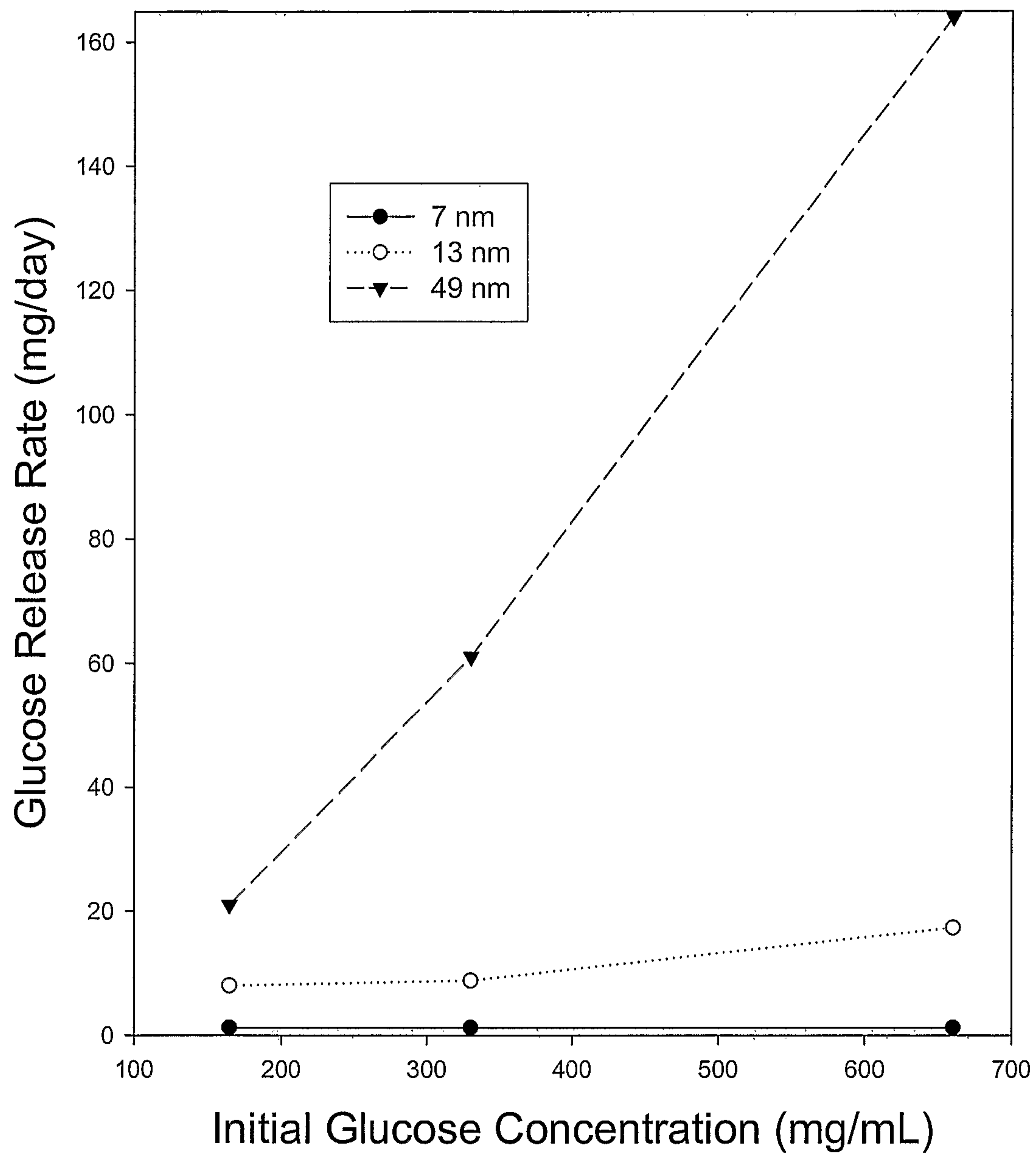

FIG. 5

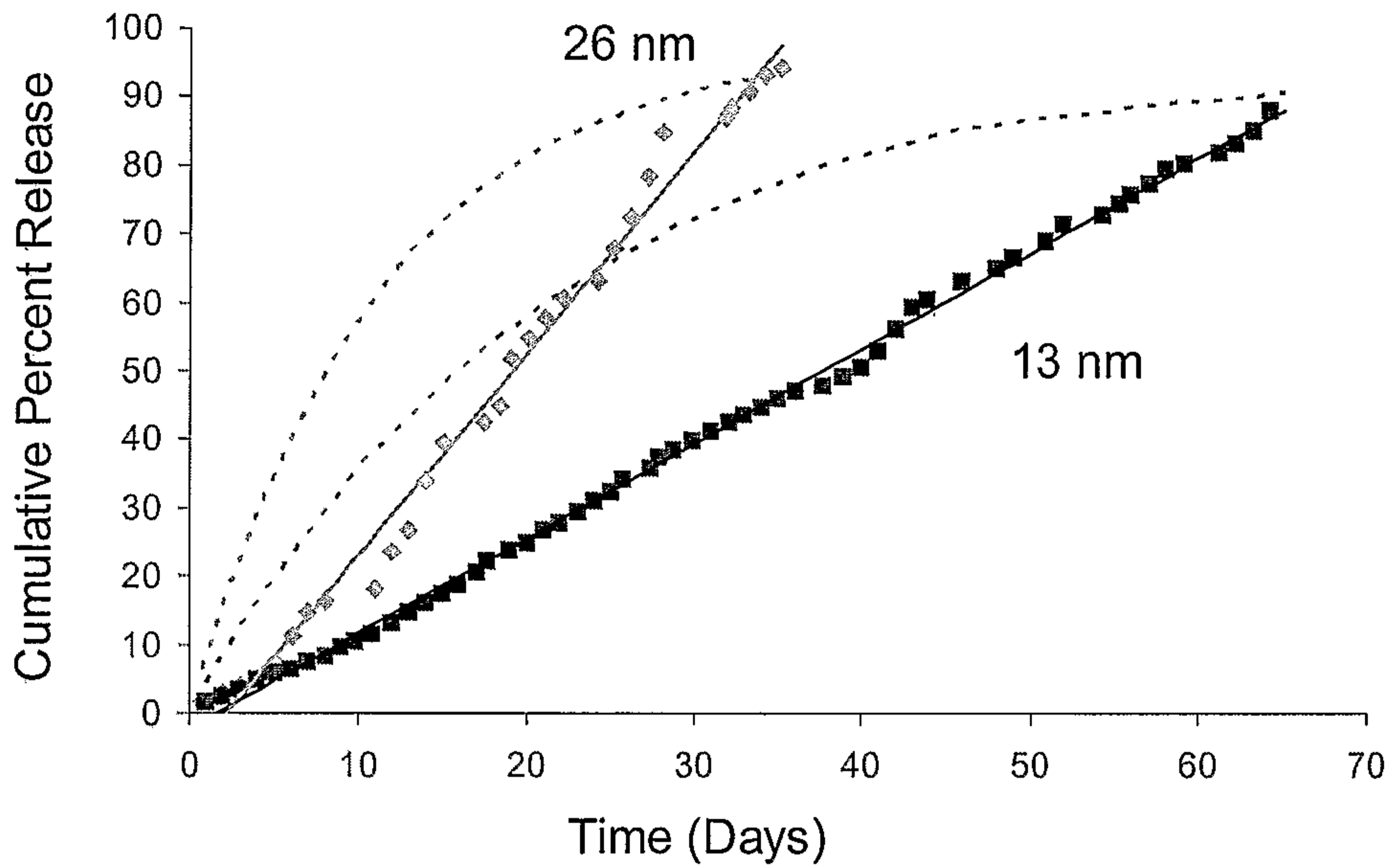

FIG. 6

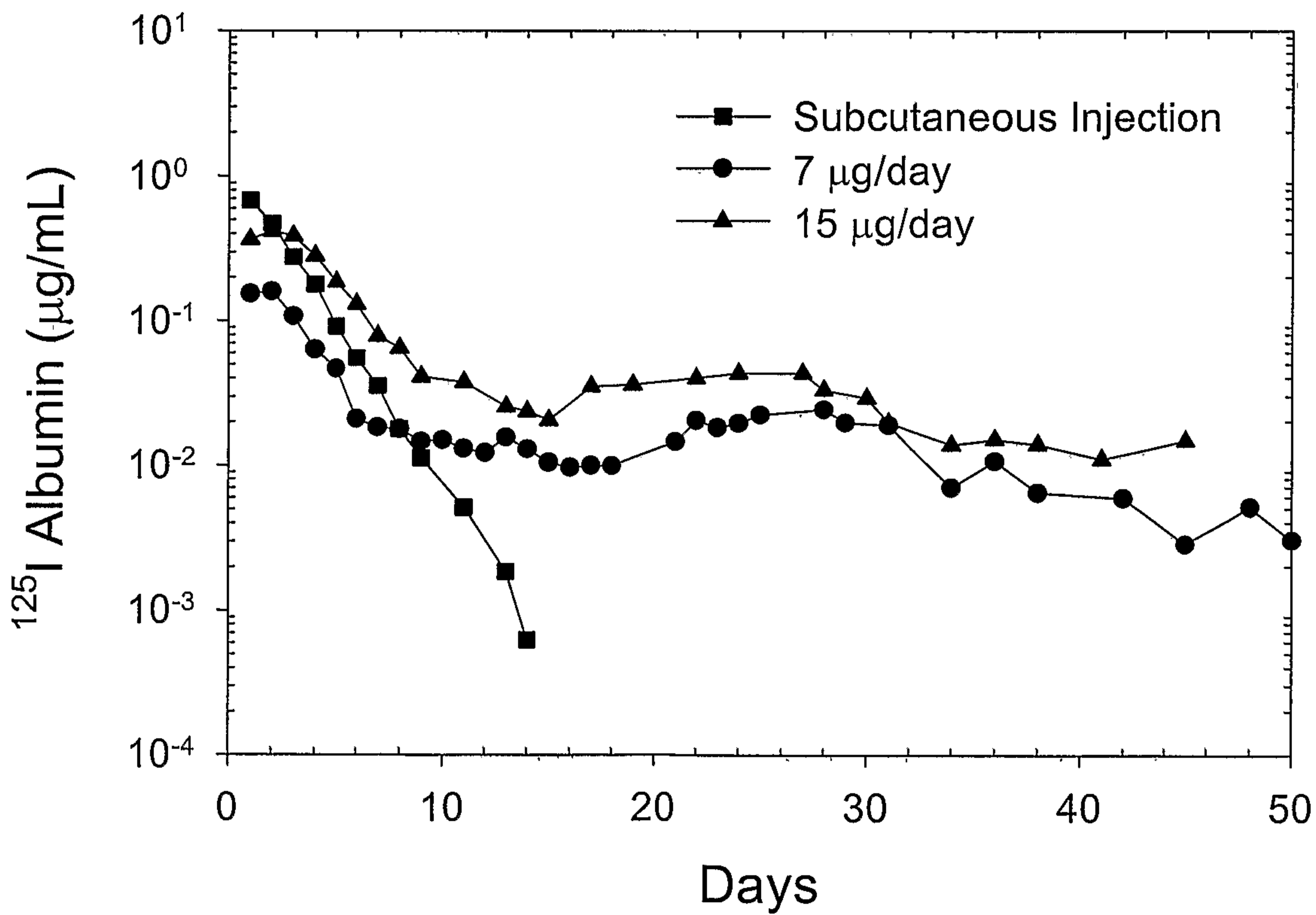

FIG. 7

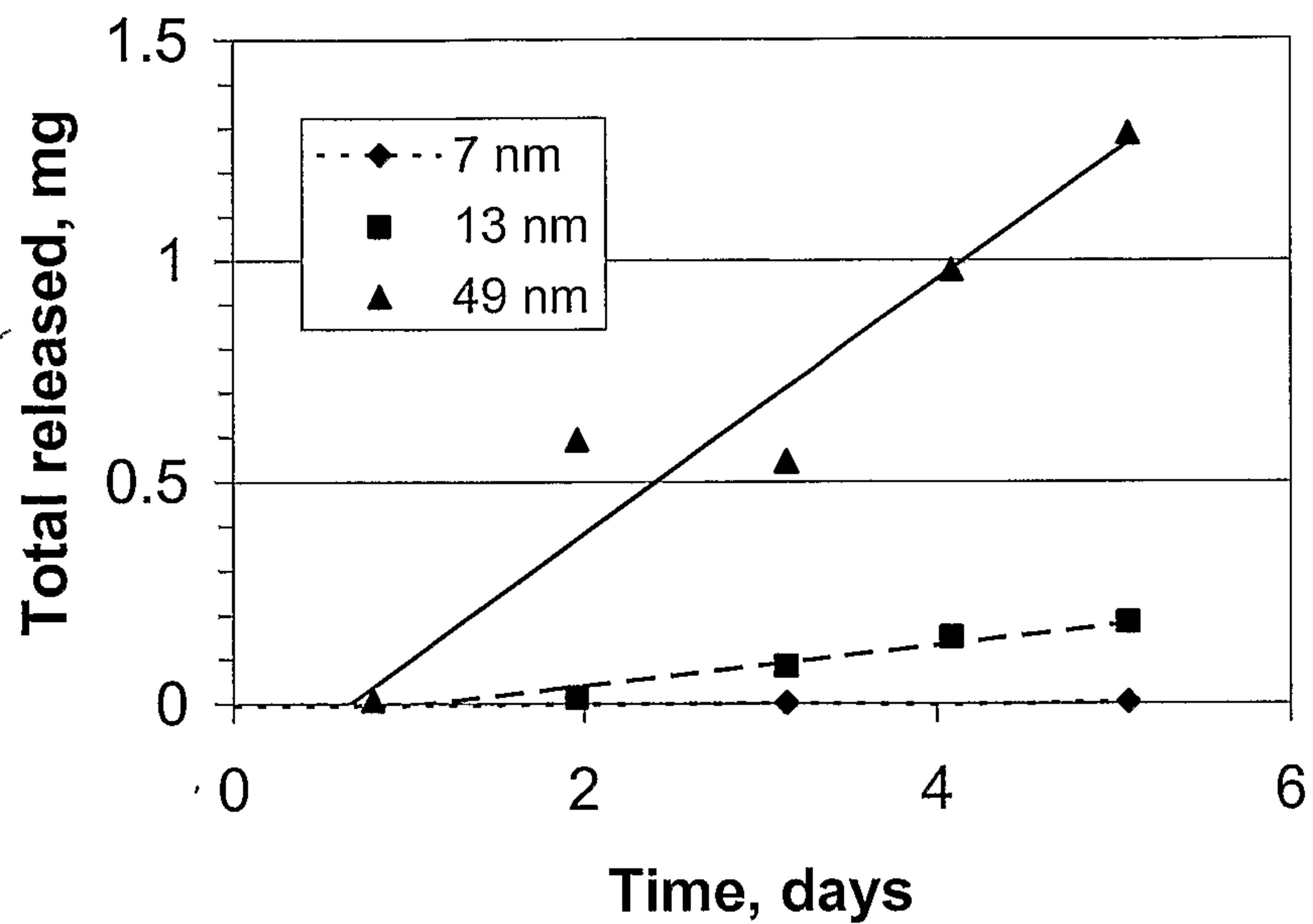

FIG. 8

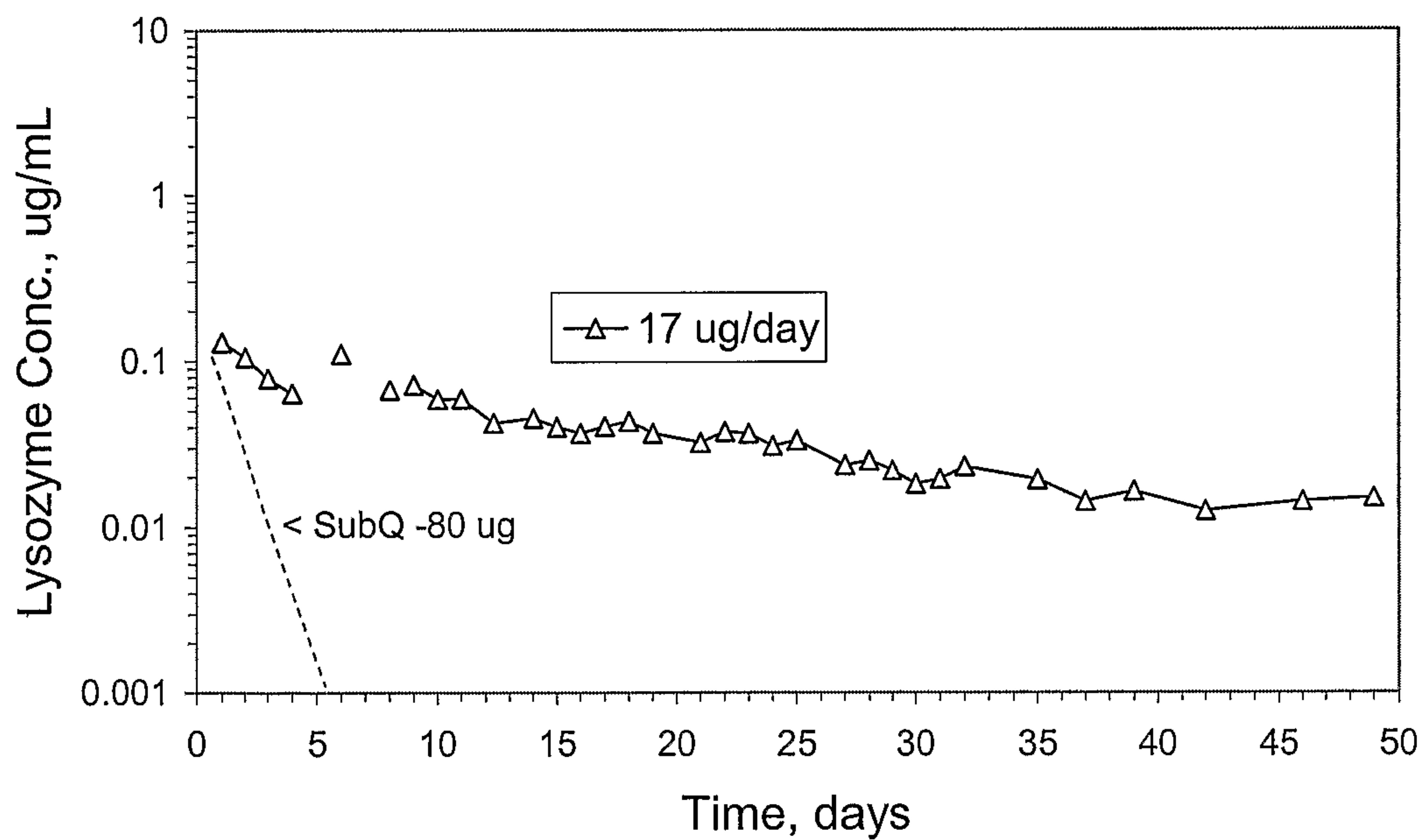

FIG. 9

