

(No Model.)

2 Sheets—Sheet 1.

S. NEVINS.
COAL WASHING MACHINE.

No. 307,573.

Patented Nov. 4, 1884.

Fig. 1

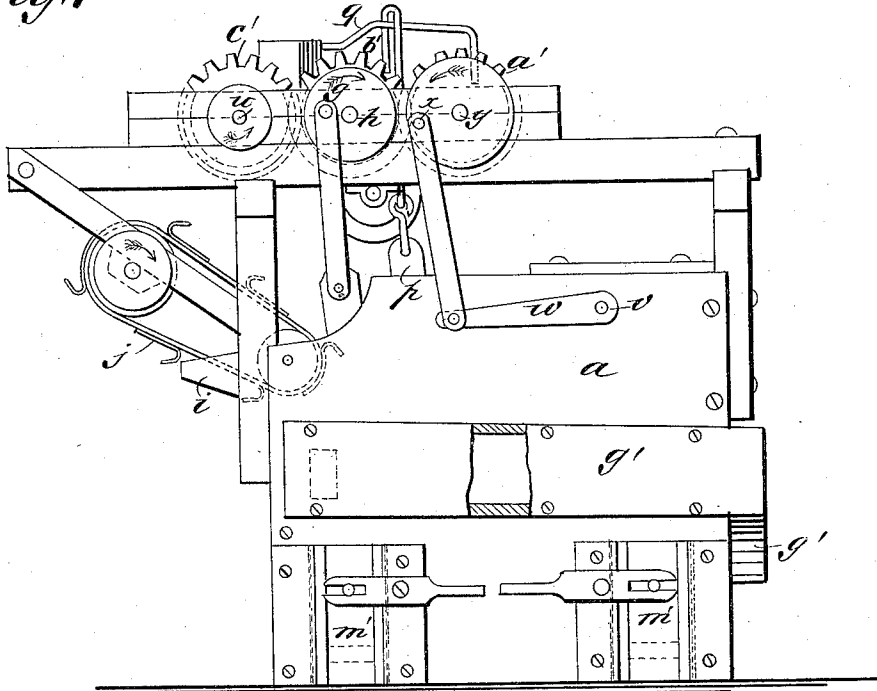
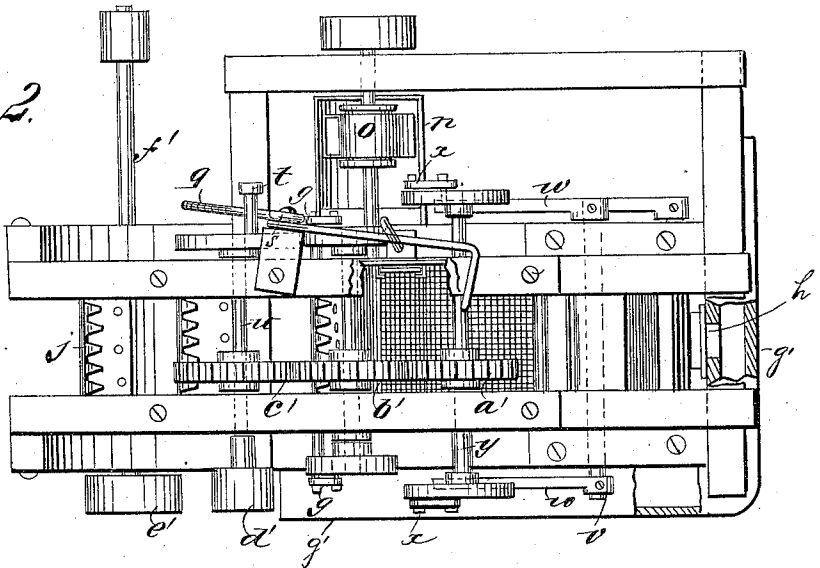

Fig. 2



WITNESSES:
J. Mc Ardle.
L. Sedgwick

INVENTOR:
S. Nevins
 BY *Munn & Co*
 ATTORNEYS.

(No Model.)

2 Sheets—Sheet 2.

S. NEVINS.
COAL WASHING MACHINE.

No. 307,573.

Patented Nov. 4, 1884.

Fig. 3

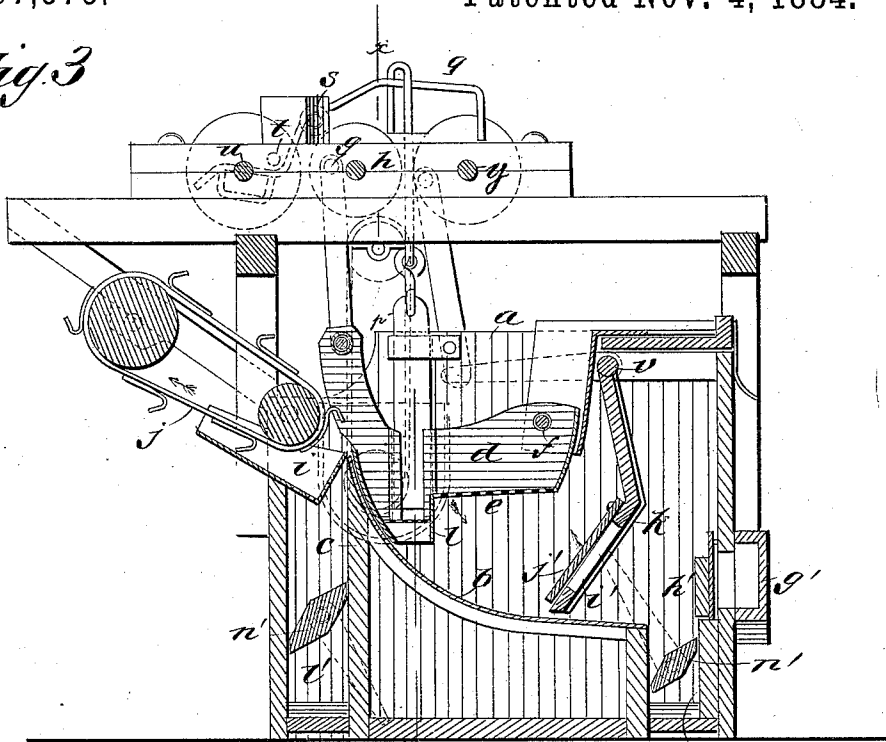
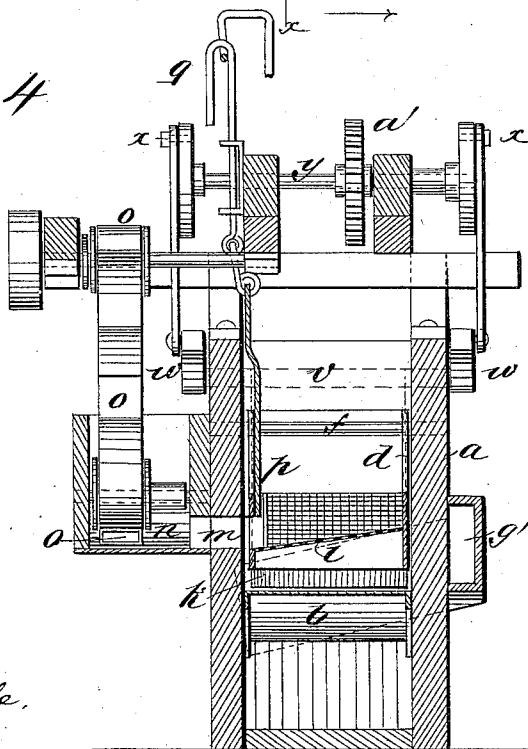

Fig. 4



WITNESSES:
Wm. McArdle,
C. Sedgwick,

INVENTOR:
S. Nevins

BY *Munn & Co.*
 ATTORNEYS.

UNITED STATES PATENT OFFICE.

SAMUEL NEVINS, OF SUMMIT HILL, PENNSYLVANIA.

COAL-WASHING MACHINE.

SPECIFICATION forming part of Letters Patent No. 307,573, dated November 4, 1884.

Application filed June 20, 1884. (No model.)

To all whom it may concern:

Be it known that I, SAMUEL NEVINS, of Summit Hill, in the county of Carbon and State of Pennsylvania, have invented a new and Improved Coal-Washing Machine, of which the following is a full, clear, and exact description.

My invention consists of an improved coal-washing machine comprising an automatic skaking-screen, water-circulating apparatus, endless coal-rake, and an endless slate-elevator in a water-tank for separating slate, fine dust, and the like from coal, and washing the coal, as hereinafter fully described and claimed.

Reference is to be had to the accompanying drawings, forming part of this specification, in which similar letters of reference indicate corresponding parts in all the figures.

Figure 1 is a side elevation of my improved coal-washing machine with a part broken out. Fig. 2 is a plan view also with some parts broken out. Fig. 3 is a longitudinal sectional elevation, and Fig. 4 is a transverse sectional elevation on the line $x x$ of Fig. 3.

In a suitable tank, a , to be nearly filled with water, and having a curved bottom, b , the upper end of which terminates at the top of a partition, c , I arrange a hopper, d , having a perforated or other open bottom, e , on a pivotal shaft, f , at one end. The other end is suspended from the crank-pins g of a revolving shaft, h , for shaking the hopper by an up-and-down motion of the suspended end, which swings parallel with the upper portion of the curved bottom b of the tank to wash the coal free of the slate and float it over the top of partition c into the spout i of an endless rake, j , by the dashing of the hopper downward against the water, and also by the dashing of the water upward at the same time against the hopper. This upward dashing of the water is accomplished by the vibrating paddle k , which swings along the bottom b under the hopper d , and is so geared with the driving mechanism that it swings upward toward the hopper at the same time that the hopper swings downward toward the paddle, thus causing the water to rise up through the bottom of the hopper with sufficient force to float the coal up into the spout i away from the slate, which separates from the coal by falling into the laterally-descending spout or chute l ,

which discharges the slate through the opening m in the side of the water-tank into the slate-hopper n , from which it is to be taken away by the endless bucket-elevator o . The bottom of the spout l is also open, like the bottom of the rest of the hopper, to allow the water to flow up through it to float the coal above the slate.

The passage m through the side of the water-tank is so located with relation to the mouth of the spout l that they coincide when the hopper is down to its lowest position, and the hopper is provided with a gate, p , which is suspended from a lever, q , having a fulcrum at s , and arranged in such relation to a crank-pin, t , of a rotating shaft, u , that said crank-pin will raise the gate and open the passage from the spout for a short time while the hopper is down in the lowest position for the escape of the slate, but will allow the gate to fall and close the spout about the time the hopper begins to rise, to prevent the escape of the coal.

The paddle k is suspended from the pivot-shaft v , which has a couple of arms, w , one at each end, which are connected to the crank-pins x of a rotating shaft, y , for working the paddle. This shaft y , the hopper-working shaft h , and the gate-working shaft u are connected for synchronous action by a train of gear-wheels, a' , b' , and c' , and shaft u has a pulley, d' , on which a belt works from the shaft f' , that drives the endless rake j and the elevator o , and to which the power for working the whole machine may be applied in any approved way.

The water beaten up through the bottom of the hopper d by the paddle k over the partition c flows back into the space behind the paddle through the return-pipe g' , and a check-valve, h' , that prevents the water from being driven backward through said pipe by the paddle, and the paddle has a large opening, i' , through it to allow the water to pass through when the paddle goes back, with a check-valve, j' , to close it on the forward stroke.

At each end of the curved bottom b of the tank is a pocket, l' , into which the fine particles of coals and other refuse washed off the coal may deposit, to be drawn off from time to time through the gates m' , and there is a

valve, *n'*, in the upper part of each pocket to close and prevent the waste of water above the deposits in said pockets when being drawn off.

5 The water may be used over again as long as it is serviceable, for economy of the same when the supply is limited.

10 The endless rake *j* and its chute *i* may be extended any approved length for discharge of the coal into a bin or other elevated receptacle.

The coal is to be fed into the hopper *d* in regulated measure by any approved means.

15 Except for retaining the water at the proper level in the tank *a*, the rake and its chute *i* and the slate hopper and its elevators might be dispensed with and the coal and the slate be discharged upon the ground.

20 Having thus fully described my invention, I claim as new and desire to secure by Letters Patent—

1. The combination, with the water-tank *a*, having curved bottom *b*, of the vibrating paddle *k* and the vertically-swinging coal-hopper *d*, said hopper having the open bottom *e* and laterally-discharging spout *l*, substantially as described.

2. The combination, with the water-tank *a*, having curved bottom *b*, of the vibrating paddle *k*, vertically-swinging coal-hopper *d*, and the vertically-reciprocating gate *p*, said hopper having the open bottom *e* and the laterally-discharging spout *l*, substantially as described.

3. The combination, with the water-tank *a*, having curved bottom *b*, of the vibrating paddle *k*, vertically-swinging coal-hopper *d*, the spout *i*, and the endless rake *j*, substantially as described.

4. The combination, with the water-tank *a*, having curved bottom *b*, of the vibrating paddle *k*, vertically-swinging coal-hopper *d*, spout *i*, rake *j*, slate-hopper *n*, and elevator *o*, said hopper *d* having the open bottom *e* and lat-

erally-discharging chute *l*, substantially as described. 45

5. The combination, with the tank *a*, having curved bottom *b*, and return-spout *g'*, of the vibrating paddle *k*, vertically-swinging hopper *d*, slate-hopper *n*, elevator *o*, coal-spout *i*, and the coal-rake *j*, said hopper *d* having the open bottom *e* and the laterally-discharging spout *l*, substantially as described. 50

6. The combination of the tank *a*, having the passage *m*, with the vertically-swinging coal-hopper *d*, having the chute *l* and the slate-hopper *n*, the said chute and passage connecting for the discharge of the slate at the end of the downstroke of the hopper, substantially as set forth. 55 60

7. The combination, with the vertically-swinging hopper *d*, having the laterally-discharging chute *l*, of the slate-hopper *n*, having passage *m*, the gate *p*, and its operating-lever adapted to operate said gate, substantially as set forth. 65

8. The tank having the curved bottom, the pockets *l'*, and valves *n'*, in combination with the washing-hopper *d* and paddle *k*, said pockets having gates *m'* for the discharge of the deposits in said pockets, substantially as described. 70

9. The vibrating paddle *k*, having passage *i'* and valve *j'*, in combination with tank *a*, having return-pipe *g'*, and check-valve *h'*, and the washing-hopper *d*, substantially as described. 75

10. The tank *a*, vibrating paddle *k*, and washing-hopper *d*, in combination with operating mechanism, whereby the paddle swings upward toward the hopper when the hopper swings downward toward the paddle, substantially as described. 80

SAMUEL NEVINS.

Witnesses:

JAMES MCCREADY,
JOHN POLLOCK.