



- (51) International Patent Classification:  
B21K 1/06 (2006.01) B22D 25/02 (2006.01)  
B21J 5/02 (2006.01)
- (21) International Application Number:  
PCT/US2013/044962
- (22) International Filing Date:  
10 June 2013 (10.06.2013)
- (25) Filing Language: English
- (26) Publication Language: English
- (30) Priority Data:  
13/551,675 18 July 2012 (18.07.2012) US
- (71) Applicant: UNITED TECHNOLOGIES CORPORATION [US/US]; One Financial Plaza, Hartford, Connecticut 06101 (US).
- (72) Inventors: BENJAMIN, Daniel; 295 Bushy Hill Road, Simsbury, Connecticut 06070 (US). MCLEOD, Steve A.; 167 Forest Street, Rocky Hill, Connecticut 06067 (US). KAPSZUKIEWICZ, Daniel R.; 265 Gendron Road, Plainfield, Connecticut 06374 (US). TIMMONS, Larry James; 71 Rising Trail Drive, Middletown, Connecticut 06457 (US). GENEREUX, Paul D.; 6061 SE Martinique Drive, Unit 202, Stuart, Florida 34997 (US).

(74) Agent: GOTTSCHALK, William S.; Carlson, Gaskey & Olds/Pratt & Whitney, C/o CPA Global, P.O. Box 52050, Minneapolis, Minnesota 55402 (US).

(81) Designated States (unless otherwise indicated, for every kind of national protection available): AE, AG, AL, AM, AO, AT, AU, AZ, BA, BB, BG, BH, BN, BR, BW, BY, BZ, CA, CH, CL, CN, CO, CR, CU, CZ, DE, DK, DM, DO, DZ, EC, EE, EG, ES, FI, GB, GD, GE, GH, GM, GT, HN, HR, HU, ID, IL, IN, IS, JP, KE, KG, KN, KP, KR, KZ, LA, LC, LK, LR, LS, LT, LU, LY, MA, MD, ME, MG, MK, MN, MW, MX, MY, MZ, NA, NG, NI, NO, NZ, OM, PA, PE, PG, PH, PL, PT, QA, RO, RS, RU, RW, SC, SD, SE, SG, SK, SL, SM, ST, SV, SY, TH, TJ, TM, TN, TR, TT, TZ, UA, UG, US, UZ, VC, VN, ZA, ZM, ZW.

(84) Designated States (unless otherwise indicated, for every kind of regional protection available): ARIPO (BW, GH, GM, KE, LR, LS, MW, MZ, NA, RW, SD, SL, SZ, TZ, UG, ZM, ZW), Eurasian (AM, AZ, BY, KG, KZ, RU, TJ, TM), European (AL, AT, BE, BG, CH, CY, CZ, DE, DK, EE, ES, FI, FR, GB, GR, HR, HU, IE, IS, IT, LT, LU, LV, MC, MK, MT, NL, NO, PL, PT, RO, RS, SE, SI, SK, SM, TR), OAPI (BF, BJ, CF, CG, CI, CM, GA, GN, GQ, GW, KM, ML, MR, NE, SN, TD, TG).

Published:  
— with international search report (Art. 21(3))

(54) Title: TIE SHAFT FOR GAS TURBINE ENGINE AND FLOW FORMING METHOD FOR MANUFACTURING SAME

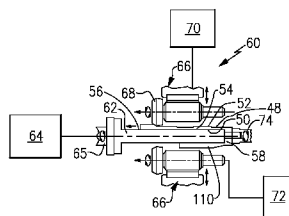


FIG. 4A

(57) Abstract: A method is disclosed for manufacturing a tie shaft for aero or land based gas turbine engine. The method includes flow forming a tie shaft preform to produce a tie shaft. In one example, the tie shaft includes a nickel alloy cylindrical wall having a length to diameter ratio of at least 6:1, wherein the diameter is an average outer diameter. The wall includes a minimum effective strain of 0.3 in/in (7.6 mm/mm), and a grain size is in the range of G4 to G16 per ASTM E112. The wall includes a roll formed threaded surface having a thread roughness of less than 1260 μin (32 microns).



**TIE SHAFT FOR GAS TURBINE ENGINE AND FLOW FORMING  
METHOD FOR MANUFACTURING SAME**

**BACKGROUND**

[0001] This disclosure relates to a tie shaft for a gas turbine engine. The disclosure also relates to a flow forming manufacturing method for producing the tie shaft.

[0002] Gas turbine engines typically include multiple spools, which are constructed from forged titanium or nickel and/or steel alloy disks connected by a shaft that is also generally made of nickel or steel alloys. Typically, an oversize long solid forging is machined to provide the desired shaft contour on the interior and exterior surfaces. This requires extensive and costly machining. In addition, any required threads must be machined into the shafts to provide securing features.

**SUMMARY**

[0003] A method is disclosed for manufacturing a tie shaft for a gas turbine engine. The method includes flow forming a tie shaft preform to produce a tubular near net shape part.

[0004] In a further embodiment of any of the above, the tie shaft preform is a nickel alloy or steel alloy.

[0005] In a further embodiment of any of the above, the method includes melting the nickel alloy using vacuum induction melting and vacuum arc remelting or vacuum induction melting, electroslag remelting, and vacuum arc remelting to produce the tie shaft preform.

[0006] In a further embodiment of any of the above, the flow forming step includes engaging an outer surface of the tie shaft preform at one end with a roller and working the outer surface from the one end to an opposite end.

[0007] In a further embodiment of any of the above, the method includes the step of flow forming in either forward or reverse directions, or a combination of the two.

**[0008]** In a further embodiment of any of the above, the flow forming step includes imparting a minimum effective strain of 0.3 in/in (7.6 mm/mm) in the tie shaft flow-formed part.

**[0009]** In a further embodiment of any of the above, the flow forming step includes producing a grain size in the range of G4 to G16 per ASTM E112.

**[0010]** In a further embodiment of any of the above, the method includes the step of trimming opposing ends of the flow formed shape to produce a tie shaft length. The tie shaft has a length to diameter ratio of at least 6:1. The diameter is an average outer diameter.

**[0011]** In a further embodiment of any of the above, the tie shaft preform has a wall thickness. The flow forming step reduces the preform wall thickness by a minimum of 30%.

**[0012]** In a further embodiment of any of the above, the method includes the separate step of roll forming threads onto the tie shaft to produce a threaded surface.

**[0013]** In a further embodiment of any of the above, the threaded surface includes threads having asymmetrical flanks.

**[0014]** In a further embodiment of any of the above, the threads have a root radius larger than 0.010 inches (0.254 mm).

**[0015]** In a further embodiment of any of the above, the threaded surface has a thread roughness of less than 1260  $\mu\text{in}$  (32 microns).

**[0016]** In one example, the tie shaft includes a nickel alloy cylindrical wall having a length to diameter ratio of at least 6:1, wherein the diameter is an average outer diameter. The wall includes a minimum effective strain of 0.3in/in (7.6 mm/mm), and a grain size is in the range of G4 to G16 per ASTM E112. The wall includes a threaded surface having a thread roughness of less than 1260  $\mu\text{in}$  (32 microns) on load flanks.

**[0017]** In a further embodiment of any of the above, the tie shaft includes multiple rotors that are secured to the cylindrical wall by a member that engages the threaded surface.

## **BRIEF DESCRIPTION OF THE DRAWINGS**

**[0018]** The disclosure can be further understood by reference to the following detailed description when considered in connection with the accompanying drawings.

[0019] Figure 1 is a schematic view of an example gas turbine engine.

[0020] Figure 2 is a highly schematic view of an example tie shaft arrangement.

[0021] Figure 3 is a flow chart depicting an example manufacturing process to produce a tie shaft flow formed shape.

[0022] Figure 4A is one example flow forming manufacturing process where rollers advance coincides with the direction of material flow (i.e forward flow-forming).

[0023] Figure 4B is another example flow forming manufacturing process where rollers advance is opposite to the direction of material flow (i.e. reverse flow-forming).

[0024] Figure 5 is a cross-sectional view of an example tie shaft.

[0025] Figure 6 is a schematic of an example thread rolling machine.

[0026] Figure 7 is a schematic, cross-sectional view of example threads formed on the tie shaft.

### DETAILED DESCRIPTION

[0027] One example gas turbine engine 10 is schematically illustrated in Figure 1. The engine 10 includes low and high spools 12, 14. Although a two-spool arrangement is illustrated, it should be understood that additional or fewer spools may be used in connection with the disclosed tie shaft arrangement.

[0028] A low pressure compressor section 16 and a low pressure turbine section 18 are mounted on the low spool 12. A gear train 20 interconnects the low spool 12 to a fan section 22, which is arranged within a fan case 30.

[0029] A high pressure compressor section 24 and a high pressure turbine section 26 are mounted on the high spool 14. A combustor section 28 is arranged between the high pressure compressor section 24 and the high pressure turbine section 26. The low pressure compressor section 16, the low pressure turbine section 18, the high pressure compressor section 24, the high pressure turbine section 26 and the combustor section 28 are arranged within a core case 34.

[0030] The engine 10 illustrated in Figure 1 provides an axial flow path through the core case 34. An example tie shaft arrangement for the gas turbine engine 10 is illustrated in Figure 2. It should be understood that the tie shaft 36 can be used for other types of

engines. A stack of high pressure compressor rotors 38 is retained by and clamped between first and second members 40, 42. The second member 42 may include a hub and/or a nut 43, for example. High pressure turbine rotors 44 are clamped between the second member 42 and a third member 46. The first, second and third members 40, 42, 46 are coupled by threads onto corresponding features on the tie shaft 36 in the example.

**[0031]** Instead of using a typical forged alloy material with predominantly axial grain flow for the tie shaft 36, a material is produced that is more isotropic and therefore more suitable for the tie shaft application, according to a process schematically illustrated at 100 in Figure 3. A nickel alloy, such as Inconel 718 is subjected to a triple melt process to produce smaller carbides in an alloy matrix and results in better distribution of the primary type carbides and less carbide stringering with a very consistent, controlled microstructure throughout the tie shaft's flow formed shape. Triple melt also provides improved homogenization and less melt segregation especially beneficial for larger shafts that require more aggressive processing like flow-forming. First, the nickel alloy is melted using a vacuum induction melt (VIM) process, as indicated at 102. The alloy then undergoes an electroslag remelt (ESR) process, as indicated at 104. The alloy is further processed using a vacuum arc remelt (VAR) process, as indicated at 106. Subsequently, the material may require forging 108 to produce a round billet of material with microstructure of ASTM G4 or finer grain size per ASTM E112. The billet is then machined to produce a tie shaft preform having a generally cylindrical tubular shape, as indicated at 110. A nickel alloy produced according to this process has reduced carbide particle size, reduced stringering of the carbides, and improved homogenization. Stringering is an alignment of carbides that can result from the flowform process. An etched metallographic cross-section of the material reveals linear-appearing carbides that look like a "string of carbides" in predominantly the axial direction. However, the carbides may also form in the circumferential direction. For some nickel alloys, a double melt process which consists of the vacuum induction melt followed by the vacuum arc remelt is sufficient to produce an acceptable preform for flow-forming at 112.

**[0032]** For comparison, Figures 4A and 4B illustrate preform 110 at the bottom of mandrel 62 and the flow formed preform shape 54 at the top of the mandrel 62.

**[0033]** Referring to Figure 4A, an example flow forming process is schematically illustrated. A nickel alloy having a thicker preform shape 48 is flow-formed to provide a relatively thin wall tie shaft shape 54 which has inner and outer surfaces 50, 52. The tie shaft flow formed shape 54 extends between first and second ends 56, 58. The preform is sized such that its volume is close to the final volume of the flow-formed shape. Generally, this shape is also a more near net shape than can be achieved through conventional processing.

**[0034]** The tie shaft preform 110 is arranged over a mandrel 62 of a flow forming machine 60. The mandrel 62 is secured to a support 65 that is rotationally driven by a motor 64. In the example, the second end 58 is secured between the mandrel 62 and a clamp 74. The mandrel 62 may provide a generally constant inner diameter, for example.

**[0035]** Two or more actuators 70, 66 move rolling members 72 axially and radially. The rolling members 72 include rollers 68 that engage the outer surface 52 of the preform 110. Rollers 68 can be either axially in line or axially staggered and/or radially staggered. In the example, the rollers 68 begin at the second end 58 and work the preform 110 towards first end 56. The combined axial and radial motion of the rollers 68 cold work the tie shaft preform 48 in a direction coincident with the advance of the rollers. The cold working of the material under the rollers causes adiabatic heating which increases the material ductility and aids in material deformation. Subsequent to flow forming, the first and second ends 56, 58 are trimmed to provide test material (outside the part shape), and a desired finish length L between ends 82 (Figure 5). The flow forming process is capable of producing a tie shaft having a length/average outer diameter ratio of at least 6:1. In one example, the inner diameter is 3.75 in. (95.3 mm) and the average outer diameter is 3.95 in. (100.3 mm). This flow forming process is designed to reduce the wall thickness from preform to flow formed shape by a minimum of 30% of preform starting wall thickness or minimum effective strain of 0.3 in/in (7.6 mm/mm). This is required to limit undesirable "critical" grain growth.

**[0036]** Another flow forming machine 160 is illustrated in Figure 4B. The mandrel 162 supports a preform 110, which is secured to the support 165. The second end 158 is unsupported relative to the mandrel 162. The rolling members 66 start at the second end 158 and work toward the first end 156 while the material flows in a direction opposite to

the advance of rollers 66. In some cases where a transition microstructure is permissible, both forward and reverse flow-forming may be used and the combination of the two.

**[0037]** The flow formed tie shaft 36 is illustrated in more detail in Figure 5. The inner surface 54 has an inner shape corresponding to the shape of the mandrel 62, in the example. A thickness of the wall 54 between the inner and outer surfaces 50, 52 is variable. In the example, first, second, third, fourth and fifth outer diameters D1, D2, D3, D4, D5 are provided.

**[0038]** In one example, the outer surface 52 includes first, second, third threaded surfaces 76, 78, 80. The threaded surfaces are provided by a thread rolling tool 84, schematically illustrated in Figure 6. A CNC machine 86 controls the thread rolling tool 84 to roll threads to provide the threaded surfaces 76, 78, 80. In one example, the thread rolling tool 84 includes multiple circumferentially arranged thread rollers 88 that each include rolling features 90 that correspond to a desired thread profile for the tie shaft 36. One example thread profile is illustrated in Figure 7, which has asymmetrical thread form 92, although symmetrical threads may also be provided. The threads 92 include roots 94 having a root radius of larger than 0.010 inches (0.254 mm) and asymmetrical load and clearance flanks 96, 98.

**[0039]** The tie shaft 36 manufactured according to the example manufacturing processes described above includes a nickel alloy cylindrical wall 54 having a length to diameter ratio of at least 6:1, wherein the diameter is an average outer diameter. The wall 54 includes a minimum effective strain of 0.3 in/in (7.6 mm/mm), and a grain size in the range of, for example, G4 to G16 per ASTM E112, and in another example, G8 to G12. The process produces small particle sizes and extent of stringering, which is the primary life limiting feature. The wall 54 includes multiple threaded surfaces, for example, first, second, third threaded surfaces 76, 78, 80, having a thread roughness of less than 1260  $\mu\text{in}$  (32 microns) over the load flanks. The flow forming and thread rolling process produces a finished tie shaft 36 having a near-net shape requiring minimal finish machining. Superior surface finish and a compressed layer on the threads ensure increased resistance to fretting and longer life. Flow formed barrels and rolled threads result in desired alignment of grain flow.

**[0040]** Although an example embodiment has been disclosed, a worker of ordinary skill in this art would recognize that certain modifications would come within the scope of the claims. For that reason, the following claims should be studied to determine their true scope and content.

## CLAIMS

What is claimed is:

1. A method of manufacturing a tie shaft for a gas turbine engine comprising:  
flow forming a tie shaft preform to produce a near net shape tie shaft.
2. The method according to claim 1, wherein the tie shaft preform is a nickel alloy or steel alloy.
3. The method according to claim 2, wherein the method includes melting the nickel alloy using vacuum induction melting and vacuum arc remelting or vacuum induction melting, electroslag remelting, and vacuum arc remelting to produce the tie shaft preform.
4. The method according to claim 1, wherein the flow forming step includes engaging an outer surface of the tie shaft preform at one end with a roller and working the outer surface from the one end to an opposite end.
5. The method according to claim 4, comprising the step of flow forming in either forward or reverse directions, or a combination of the two.
6. The method according to claim 4, wherein the flow forming step includes imparting a minimum effective strain of 0.3in/in (7.6 mm/mm) in the tie shaft flow-formed part.
7. The method according to claim 6, wherein the flow forming step includes producing a grain size in the range of G4 to G16 per ASTM E112.
8. The method according to claim 1, comprising the step of trimming opposing ends of the tie shaft to produce a tie shaft length, the tie shaft having a length to diameter ratio of at least 6:1, wherein the diameter is an average outer diameter.

9. The method according to claim 8, wherein the tie shaft preform has a wall thickness, the flow forming step reducing the preform wall thickness by a minimum of 30%.

10. The method according to claim 1, comprising the step of rolling threads onto the tie shaft to produce a threaded surface.

11. The method according to claim 10, wherein the threaded surface includes threads having asymmetrical flanks.

12. The method according to claim 11, wherein threads have a root radius larger than 0.010 inches (0.254 mm).

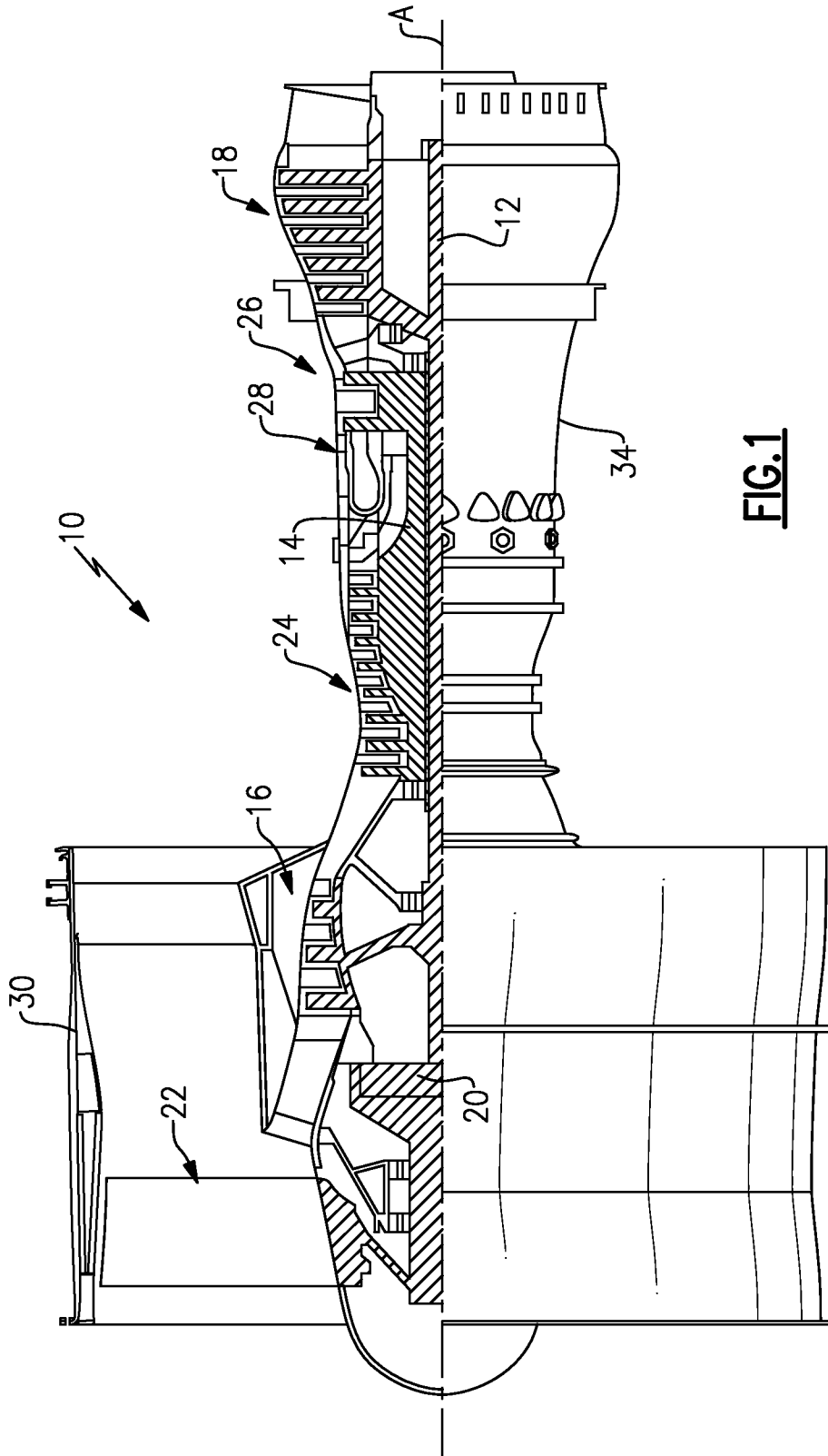
13. The method according to claim 10, wherein the threaded surface has a thread roughness of less than 1260  $\mu\text{in}$  (32 microns).

14. A tie shaft for a gas turbine engine comprising:

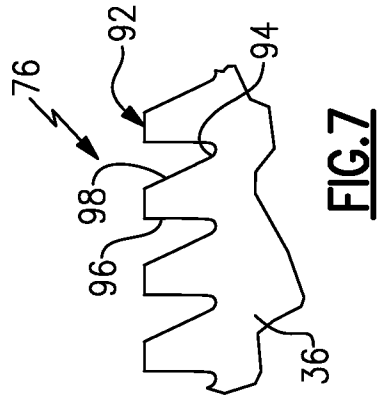
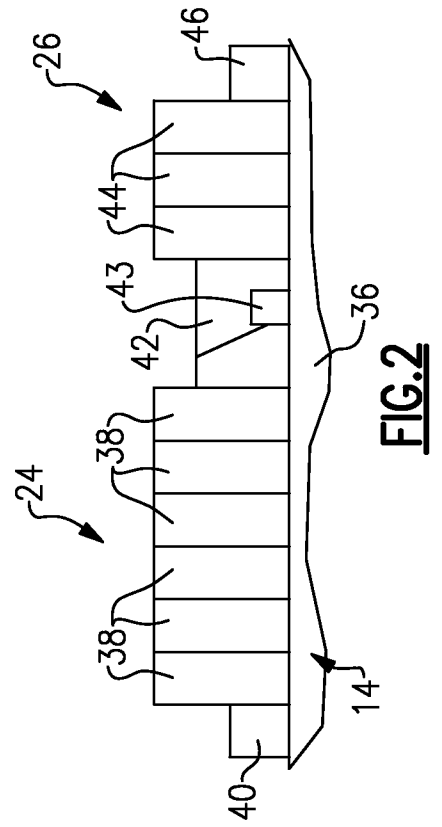
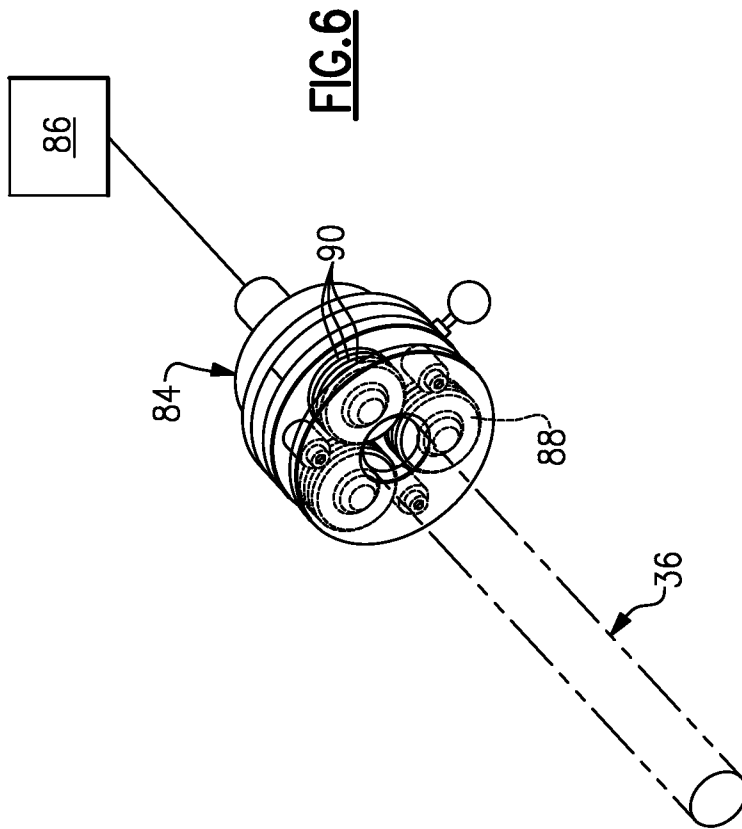
a nickel alloy cylindrical wall having a length to diameter ratio of at least 6:1, wherein the diameter is an average outer diameter, the wall having a minimum effective strain of 0.3 in/in (7.6 mm/mm), a grain size in the range of G4 to G16 per ASTM E112, and the wall including a threaded surface having a thread roughness of less than 1260  $\mu\text{in}$  (32 microns) on load flanks.

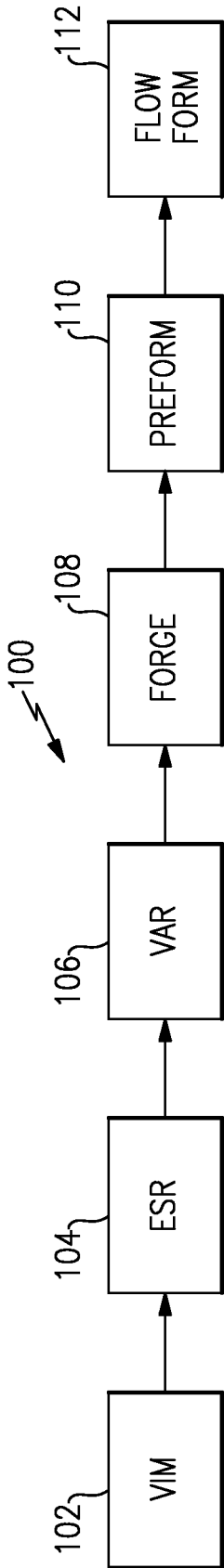
15. The tie shaft according to claim 14, comprising multiple rotors secured to the cylindrical wall by a member that engages the threaded surface.

1/4

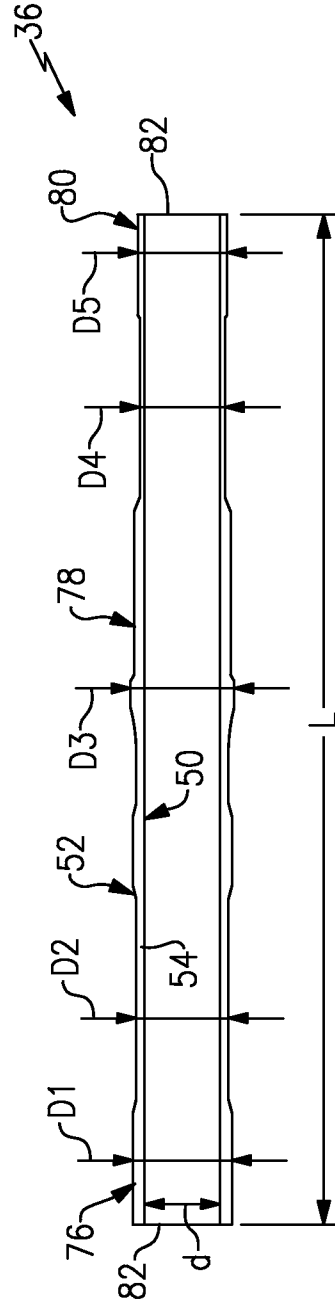


**FIG. 1**

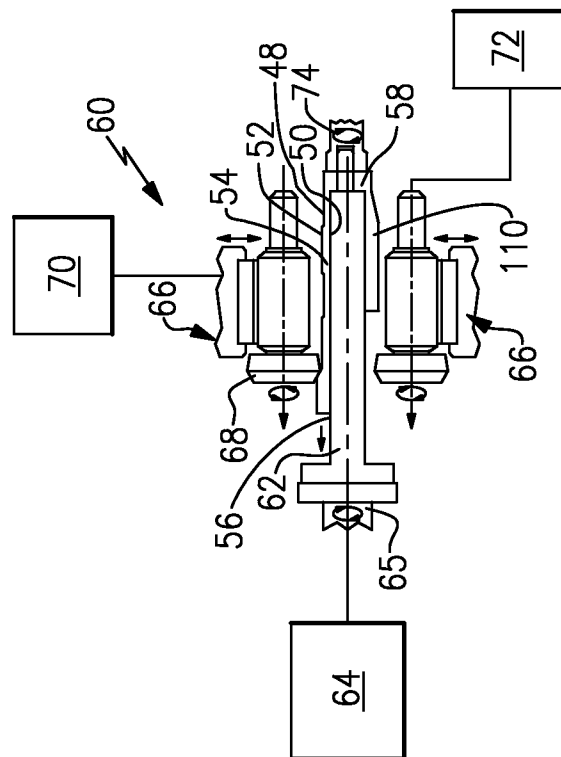




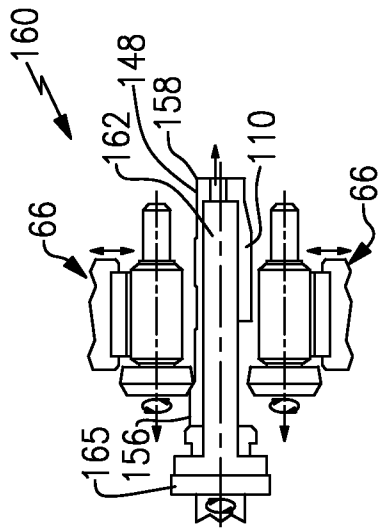
**FIG. 3**



**FIG. 5**



**FIG. 4A**



**FIG. 4B**

**A. CLASSIFICATION OF SUBJECT MATTER****B21K 1/06(2006.01)i, B21J 5/02(2006.01)i, B22D 25/02(2006.01)i**

According to International Patent Classification (IPC) or to both national classification and IPC

**B. FIELDS SEARCHED**

Minimum documentation searched (classification system followed by classification symbols)

B21K 1/06; F01D 25/00; F16C 3/00; F01D 5/06; B22D 18/02; F01D 5/02; B22D 21/04; B22F 3/15; B21J 5/02; B22D 25/02

Documentation searched other than minimum documentation to the extent that such documents are included in the fields searched

Korean utility models and applications for utility models

Japanese utility models and applications for utility models

Electronic data base consulted during the international search (name of data base and, where practicable, search terms used)

eKOMPASS(KIPO internal) &amp; keywords: flow forming, gas turbine engine, tie shaft, preform, nickel alloy, steel alloy, grain size, diameter, and strain

**C. DOCUMENTS CONSIDERED TO BE RELEVANT**

Category*	Citation of document, with indication, where appropriate, of the relevant passages	Relevant to claim No.
X	US 2012-0141294 A1 (FIELDING et al.) 07 June 2012 See abstract; paragraphs [0005],[0010]; claims 1,2.	14
Y		1-13, 15
Y	US 7485044 B2 (BRIGGS, ROGER L.) 03 February 2009 See abstract; column 2, line 56 - column 3, line 3; claim 1.	1-13
Y	US 2012-0051919 A1 (STONITSCH et al.) 01 March 2012 See abstract; paragraphs [0001]-[0003],[0020],[0022]; claims 1,2.	2,3,7
Y	KR 10-0981742 B1 (HA, TAE SOO et al.) 13 September 2010 See abstract; paragraphs [0054]-[0063].	4-7
Y	EP 2365184 A2 (UNITED TECHNOLOGIES CORPORATION) 14 September 2011 See abstract; paragraphs [0018],[0022]; claims 1,6; figure 1.	15

 Further documents are listed in the continuation of Box C. See patent family annex.

\* Special categories of cited documents:

"A" document defining the general state of the art which is not considered to be of particular relevance

"E" earlier application or patent but published on or after the international filing date

"L" document which may throw doubts on priority claim(s) or which is cited to establish the publication date of citation or other special reason (as specified)

"O" document referring to an oral disclosure, use, exhibition or other means

"P" document published prior to the international filing date but later than the priority date claimed

"T" later document published after the international filing date or priority date and not in conflict with the application but cited to understand the principle or theory underlying the invention

"X" document of particular relevance; the claimed invention cannot be considered novel or cannot be considered to involve an inventive step when the document is taken alone

"Y" document of particular relevance; the claimed invention cannot be considered to involve an inventive step when the document is combined with one or more other such documents, such combination being obvious to a person skilled in the art

"&amp;" document member of the same patent family


Date of the actual completion of the international search

02 September 2013 (02.09.2013)

Date of mailing of the international search report

**02 September 2013 (02.09.2013)**

Name and mailing address of the ISA/KR


 Korean Intellectual Property Office  
 189 Cheongsa-ro, Seo-gu, Daejeon Metropolitan City,  
 302-701, Republic of Korea

Facsimile No. +82-42-472-7140

Authorized officer

SONG Ho Keun

Telephone No. +82-42-481-5580



**INTERNATIONAL SEARCH REPORT**

Information on patent family members

International application No.  
**PCT/US2013/044962**

Patent document cited in search report	Publication date	Patent family member(s)	Publication date
US 2012-0141294 A1	07/06/2012	CA 2760454 A1 EP 2460976 A2	03/06/2012 06/06/2012
US 7485044 B2	03/02/2009	US 2006-183561 A1	17/08/2006
US 2012-0051919 A1	01/03/2012	CN 102444428 A EP 2423434 A2 EP 2423434 A3 JP 2012-051029 A KR 10-2012-0022068 A	09/05/2012 29/02/2012 12/06/2013 15/03/2012 09/03/2012
KR 10-0981742 B1	13/09/2010	None	
EP 2365184 A2	14/09/2011	US 2011-0219781 A1	15/09/2011