

(No Model.)

2 Sheets—Sheet 1.

T. C. McCLEERY.
ORE CONCENTRATOR.

No. 523,774.

Patented July 31, 1894.

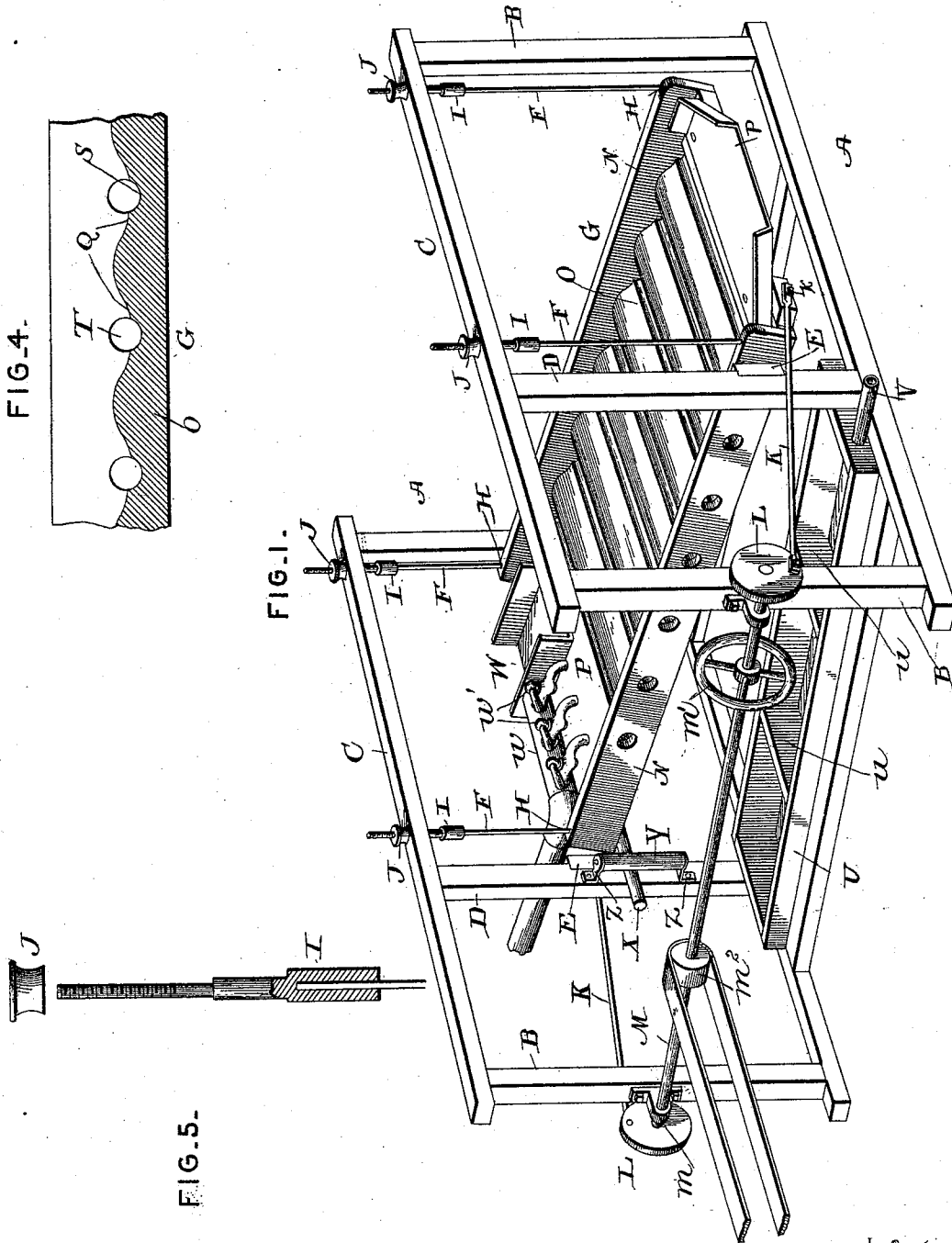

Inventor

Thomas C. McCleery

By his Attorneys,

C. A. Snow & Co.

Witnesses

Jas. H. McCutcheon
D. P. Ketchum

UNITED STATES PATENT OFFICE.

THOMAS C. McCLEERY, OF EXETER, NEBRASKA.

ORE-CONCENTRATOR.

SPECIFICATION forming part of Letters Patent No. 523,774, dated July 31, 1894.

Application filed June 27, 1893. Serial No. 478,981. (No model.)

To all whom it may concern:

Be it known that I, THOMAS C. McCLEERY, a citizen of the United States, residing at Exeter, in the county of Fillmore and State of Nebraska, have invented a new and useful Ore-Concentrator, of which the following is a specification.

This invention relates to ore concentrators; and it has for its object to provide a machine of this character, the table of which is constructed with special reference to the thorough and complete separation and concentration of the heavy particles of ore from the lighter particles of sand and other foreign matter, such ore together with the sand and other matter being the tailings from ordinary quartz mills.

To this end the main and primary object of the present invention is to provide certain improvements in ore concentrating tables whereby the concentration of the ore will be more efficiently and economically secured.

With these and other objects in view which will readily appear as the nature of the invention is better understood, the same consists in the novel construction, combination and arrangement of parts hereinafter more fully described, illustrated and claimed.

In the accompanying drawings:—Figure 1 is a perspective view of an ore concentrator constructed in accordance with this invention. Fig. 2 is a central longitudinal sectional view of the same. Fig. 3 is a vertical transverse sectional view on the line $x-x$ of Fig. 2. Fig. 4 is an enlarged detail sectional view of a portion of the concentrating table. Fig. 5 is a detail sectional view of the adjustable connection of the upper ends of the hanger wires with the upper frame cross bars.

Referring to the accompanying drawings, A represents a suitably constructed base frame from opposite ends or sides of which arise the opposite frame uprights or posts B, connected at their upper ends by the opposite upper frame cross bars C, thus completing a strong frame work for the several parts of the machine, and the intermediate frame uprights or posts, which may be designated as D, also act in the capacity of stationary strike posts provided at one side thereof with the cushion buffers E, the function of which will presently appear.

Suspended within the frame work by the hanging or suspending wires F, is the inclined concentrating table G. The hanging or suspending wires F, which loosely suspend the concentrating table G, in an inclined position, are suitably attached at their lower ends as at H, to the four corners of the table and have attached to their upper ends the threaded adjusting stems I, projecting through perforations in the upper cross bars C, of the frame, and engaged at their extremities above said cross bars by the adjusting nuts J, which provide means for adjusting the inclination or pitch of the table either longitudinally or laterally, as the character of the work may demand.

By suspending the concentrating table G, on the wires F, the same is left free to have a laterally swinging or vibrating movement between the intermediate strike posts D, and a pair of the other posts B, and in this laterally swinging or vibrating movement, one side of the said concentrating table is brought into a striking contact against the cushion buffers E, of the strike posts intermittently, in order to provide for the discharge of the concentrates on the table therefrom in the manner to be presently described, and this lateral movement of the concentrating table is effected by means of the oppositely located and oppositely moving pitmen K. The pitmen K, are pivotally connected at one end as at k , to the higher and lower ends of the concentrating table, respectively, and near the discharge side thereof, and are attached at their other ends to the crank wheels L, at both extremities of the longitudinally arranged drive shaft M. The longitudinally arranged drive shaft M is mounted in suitable bearings m , at one side of the frame and carries a balance wheel m' , and a belt pulley m^2 , over which passes a suitable drive belt for communicating motion to the ore concentrating table.

Referring more particularly to the construction of the laterally vibrating and jarring concentrating table, the same comprises the opposite side pieces N, connected by the imperforate bottom O. The imperforate bottom O, of the concentrating table leads from the upper receiving board P, to the lower tail or discharge chute p , and said bottom O, is

provided with a regular series of transverse oval depressions Q, forming an alternate series of oval ridges, which combine with the depressions to form a waving concentrating surface over which the water and tailings run in regular waves, conforming to the configuration of the table bottom, and thereby securing a thorough concentration of the ore out of the tailings. In the bottom of the oval depressions Q, are formed the sunken semi-circular discharge grooves S. The discharge grooves S, formed in the oval depressions Q, also extend transversely of the concentrating table and lead at one end into the side discharge openings T, formed in one of the side pieces N, of the concentrating table, and through which are designed to pass the concentrates which fall into the receiving and grading trough U. The trough U, is mounted on the base frame A, and is disposed slightly under the discharging side of the concentrating table, and may be provided with one or more partitions *u*, according to the number of grades into which it is desired to collect the concentrates. An overflow pipe V, is connected with one end of the trough U to carry off the overflow of water therefrom.

Suitably arranged over the higher receiving end of the concentrating table and discharging onto the receiving board P, at the upper end thereof, is the feed spout or trough W, through which the ore and water pass from any quartz mill to which the concentrator may be attached, and alongside of the feed spout or trough is arranged an auxiliary or supplemental water supply pipe *w*, provided with a series of valved discharge nozzles *w'*, which provide means for regulating the necessary amount of water supply, in order to thoroughly wash away all the sand and waste, thereby leaving the concentrates perfectly clean in the semi-circular discharge grooves S, of the table.

The concentrating table G, is held steady in its lateral vibrations by means of the transverse guide rod X. The transverse guide rod X, is secured to the bottom of the concentrating table at the higher end thereof and projects beyond the opposite sides of the table so as to work in rear of the vertical guide rollers Y. The vertical guide rollers Y, are mounted on off-standing brackets Z, attached to the frame uprights or posts at each side of the concentrating table.

Now from the foregoing it is thought that the construction and operation of the herein described concentrator will be perfectly clear to those skilled in the art. In the first place, the specific construction of the bottom of the table provides for directing the tailings and water thereover in even waves, so that the heavier particles of ore will settle in the semi-circular discharge grooves in the bottom of the oval depression, and will thus be thoroughly separated and concentrated from the sand and other matter, which are washed off at the lower end of the table by the running

water. The constant side jarring of the table causes the concentrates to be jarred out of the grooves S, and through the side discharge openings T, from which the concentrates fall into the grading trough U, at one side of the table. The surplus water supply greatly aids the operation of cleaning the concentrates perfectly of the sand and other matter.

Slight modifications in the construction described might readily suggest themselves, and I will therefore have it understood that changes in the form, proportion and the minor details of construction may be resorted to without departing from the principle or sacrificing any of the advantages of this invention.

Having thus described the invention, what is claimed, and desired to be secured by Letters Patent, is—

1. In an ore concentrator, the combination of the frame having stationary upright strike posts, an inclined laterally swinging concentrating table suspended within the frame and having an imperforate bottom provided with transverse grooves, and side discharge openings perforating one of its sides and communicating with one end of said grooves, a suitably arranged guide to hold the table against longitudinal movement and means for intermittently moving the perforated discharging side of the concentrating table against said strike posts, substantially as set forth.

2. In an ore concentrator, the combination of a frame having strike posts, an inclined concentrating table arranged within said frame and having an imperforate grooved bottom and side discharge openings communicating with one end of the grooves in said bottom, hanging or suspending wires attached at their lower ends to said table and adjustably at their upper ends to the top of the frame, a transversely arranged guide for said table to prevent longitudinal movement thereof, and means for moving the discharging side of said table against said strike posts, substantially as set forth.

3. An imperforate ore concentrating table arranged at an inclination and provided with a regular series of alternate oval depressions and ridges forming a waving concentrating surface semi-circular discharge grooves formed in the bottom of said depressions, and side discharge openings communicating with one end of the discharge grooves, substantially as set forth.

4. In an ore concentrator, the frame, an inclined swinging concentrating table suspended within the frame and provided with an imperforate bottom having a regular series of oval depressions and transverse semi-circular discharge grooves in the bottom of said depressions, and side discharge openings leading from one end of said grooves, a partitioned grading trough arranged below one side of the table, a feed spout or trough arranged over the higher receiving end of the

table, a supplemental water supply pipe, and means for imparting to said table a lateral jar, substantially as set forth.

5 In an ore concentrator, the frame having upright posts certain of which form strike posts, vertical guide rollers attached to separate posts at one end of the frame, an inclined concentrating table suspended within the frame and having side discharge openings,
10 means for jarring the table laterally against the strike posts, and a transverse guide rod

secured to the higher end of the table and having its projecting extremities working behind said guide rollers, substantially as set forth.

In testimony that I claim the foregoing as my own I have hereto affixed my signature in the presence of two witnesses.

THOMAS C. McCLEERY.

Witnesses:

C. C. SMITH,
J. S. McNAY.

15