

(19) **DANMARK**

(10) **DK/EP 3514101 T3**



Patent- og  
Varemærkestyrelsen

(12) **Oversættelse af  
europæisk patentskrift**

- 
- (51) Int.Cl.: **B 66 C 23/90 (2006.01)**                      **B 60 P 1/54 (2006.01)**                      **B 66 C 13/40 (2006.01)**  
**B 66 C 23/70 (2006.01)**
- (45) Oversættelsen bekendtgjort den: **2021-06-14**
- (80) Dato for Den Europæiske Patentmyndigheds bekendtgørelse om meddelelse af patentet: **2021-03-17**
- (86) Europæisk ansøgning nr.: **19152992.4**
- (86) Europæisk indleveringsdag: **2019-01-22**
- (87) Den europæiske ansøgnings publiceringsdag: **2019-07-24**
- (30) Prioritet: **2018-01-23 IT 201800001688**
- (84) Designerede stater: **AL AT BE BG CH CY CZ DE DK EE ES FI FR GB GR HR HU IE IS IT LI LT LU LV MC MK MT NL NO PL PT RO RS SE SI SK SM TR**
- (73) Patenthaver: **EFFER S.r.l., Via IV Novembre, 12, 40061 Minerbio (BO, Italien**
- (72) Opfinder: **CHIFFI, Giampaolo, Via Savena Vecchia, 78/1, 40052 BARICELLA (BOLOGNA), Italien**  
**IRENZE, Attilio, Via Ghirardacci, 8, 40137 BOLOGNA, Italien**
- (74) Fuldmægtig i Danmark: **Plougmann Vingtoft A/S, Strandvejen 70, 2900 Hellerup, Danmark**
- (54) Benævnelse: **KRAN**
- (56) Fremdragne publikationer:  
**WO-A1-2017/135382**  
**US-A- 4 211 332**  
**US-A1- 2017 036 894**  
**US-B1- 6 170 681**



# DESCRIPTION

[0001] This invention relates to a crane for moving loads.

[0002] The crane is, in particular, mounted on a respective movable transport vehicle, preferably in the form of a vehicle movable on the road, in particular the vehicle being in the form of a truck which has a respective box for supporting the load in which is positioned the crane.

[0003] There are prior art cranes for moving loads which are mounted on a corresponding truck which has a respective box for supporting the load in which is positioned the crane.

[0004] The prior art cranes comprise an arm for supporting the load which is telescopically movable in a plurality of positions of extension included between a retracted position and a position of maximum extension and which comprises a plurality of sliding members, and have the respective supporting arm which is rotatable angularly, in particular horizontally, relative to a respective axis of rotation of the crane and can therefore be positioned in different angular positions of rotation.

[0005] The prior art cranes also comprise means which are designed to stabilise the crane to avoid the risk of overturning during the working operations of the arm, the stabilising means being configurable in a plurality of stabilising configurations of the crane.

[0006] One problem seen in relation to these prior art cranes regards the fact that the user, whilst operating the crane, it is not able to know with certainty whether the operation is being performed in a dangerous condition or not.

[0007] In fact, the manufacturers of these cranes usually provide the users with information regarding the maximum load which can be lifted by the crane, in the condition of maximum stability.

[0008] For example, a crane of known type is described and illustrated in document US2017/036894.

[0009] Sometimes, however, it is necessary to operate in ambient conditions in which the condition of maximum stability is not achievable and in these cases the personnel cannot know whether the operation is being carried out safely or not.

[0010] The need is therefor felt in the sector to provide a crane which allows the users to operate in a safe fashion.

[0011] However, the need is felt in the sector to provide a crane which is particularly reliable.

**[0012]** Moreover, the need is felt in the sector to provide a crane which allows users to operate in a particularly fast manner.

**[0013]** The need is also felt in the sector to provide a crane which is easy to use.

**[0014]** In addition, the need is felt in the sector to provide a crane which allows the user to foresee which manoeuvres can be performed safely.

**[0015]** Some cranes are described in patent documents WO2017/135382, US4211332, US6170681.

**[0016]** The present invention therefore proposes a new and/or alternative solution to the solutions known up to now and, more specifically, proposes to overcome one or more of the above mentioned drawbacks or problems and/or to meet one or more of the needs felt in the trade or inferable from the above.

**[0017]** A crane is therefore provided for moving loads, in particular mounted on a respective movable transport vehicle, preferably in the form of a vehicle movable on the road, in particular the vehicle being in the form of a truck which has a respective box for supporting the load in which is positioned the crane; the crane comprising an arm for supporting the load which is telescopically movable in a plurality of positions of extension included between a retracted position and a position of maximum extension and which comprises a plurality of sliding members; the supporting arm being rotatable angularly, in particular horizontally, relative to a respective axis of rotation of the crane and it can be positioned in different angular positions of rotation; the crane also comprising means which are designed to stabilise the crane to avoid the risk of overturning during the working operations of the arm, the stabilising means being configurable in a plurality of stabilising configurations of the crane. It comprises means which are designed to indicate, in particular to the user of the crane, the maximum load which can be lifted by the crane, that is to say, by the arm of the crane, as a function of the condition of extension of the arm and/or the respective angular position of rotation of the arm.

**[0018]** In this way, it is possible to immediately inform the personnel regarding the operating capacity of the apparatus and it is therefore possible to operate in complete safety.

**[0019]** It comprises means for controlling the load movement arm of the crane; the indicator means are located at the control means of the crane; characterised in that the indicator means comprise a respective screen page, on a corresponding display unit of the crane, the screen page comprising symbols indicating the number of sliding members which are in an extended condition.

**[0020]** The screen page comprises a plurality of zones, in particular situated at the symbols, in particular alongside the symbols, in which is indicated, or displayed, the respective value of the maximum load in the respective condition of extension of the arm of the crane.

**[0021]** There are means for displaying in succession, on the display means of the crane, the values of maximum load as a function of the number of sliding members of the arm which are in the extended condition, at respective angular positions of rotation of the arm, the displaying means comprising respective key means.

**[0022]** The screen page comprising an area in which is indicated, or displayed, the respective angular position of rotation for which are indicated, or displayed, the values of maximum load which can be lifted.

**[0023]** This and other innovative aspects, or specific advantageous embodiments, are set out in the appended claims and its technical features are apparent from the detailed description which follows of a preferred, advantageous embodiment which must, however, be considered purely as a non-limiting example of the invention; the description being made with reference to the accompanying drawings, in which:

- Figure 1 is a schematic side view of a preferred embodiment of the crane;
- Figure 2 is a schematic front elevation view of a remote control which can be used in the crane;
- Figures 3 to 5 illustrate respective schematic views which show different operational situations of the embodiment of the crane according to the invention;
- Figure 6 is a flow diagram of the preferred process, implemented by a respective software, to obtain the maximum load values which can be lifted.

**[0024]** The accompanying drawings illustrate a preferred embodiment of a crane 10 for moving loads 13, in particular mounted on a respective movable transport vehicle, preferably in the form of a vehicle movable on the road, in particular the vehicle being in the form of a truck 11 which has a respective box for supporting the load 111 in which is positioned the crane 10.

**[0025]** As may be inferred from the drawings, the crane 10 comprises an arm 12 for supporting the load 13 which is telescopically movable in a plurality of positions of extension included between a retracted position and a position of maximum extension and which comprises a plurality of sliding members 121.

**[0026]** As may be inferred from the drawings, the supporting arm 12 is rotatable angularly, in particular horizontally, relative to a respective axis of rotation "P" of the crane 12 and it can be positioned in different angular positions of rotation, in particular situated along an angular range of extension of 360°.

**[0027]** As may be inferred from the drawings, the crane 10 also comprising means 14 which are designed to stabilise the crane 12 to avoid the risk of overturning during the working operations of the arm 12, the stabilising means 14 being configurable in a plurality of stabilising configurations of the crane 12, as described in more detail below.

**[0028]** More specifically, as may be inferred from Figure 1, each sliding member 121 is movable, in particular slidable, relative to the adjacent sliding member between a respective retracted position relative to the adjacent, or upstream, sliding member 121 and a respective extended position relative to the adjacent, or upstream, sliding member 121, for respectively extending and withdrawing the arm 12.

**[0029]** More specifically, moreover, the arm 12 for moving the load 13 can be positioned in respective inclined positions, in particular inclined with respect to a corresponding horizontal plane, between a maximum angular or inclined position, wherein the arm 12 can reach the maximum height for moving the load 13, and a minimum angular or inclined position, wherein the arm 12 can reach the minimum height for moving the load 13.

**[0030]** More specifically, as may be inferred from the drawings, the means 14 which are designed to stabilise the crane 12 to avoid the risk of overturning during the working operations of the arm 12 comprise one or more elements, or feet, for resting on the ground, 141, in particular in this embodiment there are four feet 141 resting on the ground which are each supported by the end of the rod of a respective jack preferably vertical 140 which can each be respectively positioned in a plurality of stabilising positions of the crane 12, between a respective position close to the crane 12, or to the vehicle 11 supporting the crane 12), and a position furthest away from the crane 12, or the vehicle 11 for supporting the crane 12.

**[0031]** In effect, as illustrated, the elements, or feet, for resting on the ground, 141, which are supported at the end of the rod of respective vertical jacks 140, are supported by respective sliding members 142 which are movable, in particular transversely or horizontally, between a position retracted in a corresponding housing 143 fixed to the vehicle 11, and a maximum extension position wherein the sliding members 142 are outside the housing, in particular tubular, 143.

**[0032]** As illustrated, the means 14 which are designed to stabilise the crane 12 are fixed, or extend, from the frame of the vehicle for supporting the crane, in particular laterally to the latter.

**[0033]** In the crane 10 there are means 18 which are designed to indicate, in particular to the user of the crane 10, the maximum load which can be lifted by the crane, that is to say, by the arm of the crane 10, as a function of the condition of extension of the arm 12 and/or the respective angular position of rotation of the arm 12.

**[0034]** In this way, it is possible to immediately inform the personnel regarding the operating capacity of the apparatus and it is therefore possible to operate in complete safety.

**[0035]** As may be inferred in particular from the drawing, the means 18 for indicating the maximum load which can be lifted by the crane, that is to say, by the arm of the crane, are in the form of means which display the maximum load which can be lifted.

**[0036]** As may be inferred in particular from Figure 2, there are means 16 for controlling the crane 12, in particular the arm 12 for moving the load of the crane 10.

**[0037]** As may be inferred from Figures 2 to 5, the indicator means 18 are provided at the means 16 for controlling the crane 12, in particular for controlling the load movement arm 12 of the crane 10.

**[0038]** More specifically, as may be inferred from Figure 2, the control means of the crane 10, or of the arm 12, comprise a display unit 15 and respective manual control means, in particular in the form of pushbuttons and/or respective control levers 160, which can be suitably operated by the user.

**[0039]** Advantageously, as may be inferred from Figures 3 to 5, the display unit 15 of the means 16 for controlling the crane 12, in particular for controlling the load movement arm 12 of the crane 10, is designed to define the means 18 for indicating the maximum load which can be lifted.

**[0040]** Advantageously, as may be inferred from Figure 2, the means 16 for controlling the crane 12, in particular the load movement arm 12 of the crane 10, are in the form of a remote control device, in particular portable, having a respective display unit 15.

**[0041]** Advantageously, as may be inferred from Figures 3 to 5, the means 18 which are designed to indicate to the user the maximum load which can be lifted by the crane 10, that is to say, by the arm 12 of the crane 10, indicate, in particular progressively, for the respective angular position of rotation 182, the maximum load which can be lifted as a function of the number of sliding members 121 of the arm 12 which are in the extended condition.

**[0042]** In this way, the user can immediately understand the current working condition and can understand the corresponding operating decisions.

**[0043]** As may be inferred from Figures 3 to 5, the means 18 which are designed to indicate to the user the load which can be lifted by the crane 10, that is to say, the load which can be lifted by the arm 12 of the crane 10, provide, or comprise, a respective screen page, on a corresponding display unit 15 of the crane 12, the screen page comprising symbols 180 indicating the number of sliding members 121 which are in the extended condition or not; the symbols being in particular, as illustrated in Figures 3 to 5, in the form of a sequence of natural numbers between the number zero and the number of the sliding members 121 of the respective arm 12 of the crane 10.

**[0044]** As may be inferred from Figures 3 to 5, the means 18 which are designed to indicate to the user the load which can be lifted by the crane 10, that is to say, the load which can be lifted by the arm (12) of the crane 10, provide a respective screen page, on a corresponding display unit 15 of the crane 12, the screen page comprising a plurality of zones 181, in particular situated at the symbols, in particular alongside the symbols 180, in which is indicated, or

displayed, the respective value, for example, as illustrated, expressed in kilograms, of the maximum load which can be lifted by the crane 10, or by the arm 12 of the crane 10, in the corresponding working condition, that is, in the respective condition of extension of the arm 12 of the crane 10.

**[0045]** As may be inferred from Figures 3 to 5, the means 18 which are designed to indicate to the user the load which can be lifted by the crane 10, that is to say, the load which can be lifted by the arm 12 of the crane 10, provide a respective screen page, on a corresponding display unit 15 of the crane 12, the screen page comprising an area 182 in which is indicated, or displayed, the respective angular position of rotation for which are indicated, or displayed, the values of maximum load which can be lifted 181.

**[0046]** Advantageously, there are electronic processing means, not illustrated in detail in the accompanying drawings, implementing a corresponding process, through a respective program or software, which are designed to determine or calculate the maximum load which can be lifted by the crane 12, that is to say, by the arm 12 of the crane 10, as a function of the condition of extension of the arm 12 and/or the respective angular position of rotation of the arm 12.

**[0047]** Advantageously, as may be inferred in particular from Figure 6 which illustrates a flow diagram of the process implemented by the crane, the means for determining, or calculating, the maximum load which can be lifted by the crane 12, that is to say, by the arm 12 of the crane 10, as a function of the condition of extension of the arm 12 and/or the respective angular position of rotation of the arm 12, comprise respective means 22 which measure the specific configuration of the stabilising means 14 of the crane 12, in the respective working condition, in particular the configuration being defined by the respective condition or the extension position of the sliding members 142 for supporting the means 141 for resting on the ground of the stabilising means 14.

**[0048]** Advantageously, the means 22 designed to measure the configuration of the stabilising means 14 comprise sensor means, which are not illustrated in detail in the accompanying drawings, which are designed to measure the length of extension of the sliding members 142 which carry the respective means 14 for resting on the ground.

**[0049]** Advantageously, as may be inferred in particular from Figure 6, the means designed to indicate to the user the load which can be lifted by the crane 10, that is to say, by the arm 12 of the crane 10, comprise respective means 26, in particular including, or in the form of corresponding, software means or program instructions, which are designed to calculate the limit of stability point by point around the crane 10, in particular as a function of the configuration of the stabilising means 14 of the crane 12.

**[0050]** Advantageously, as may be inferred in particular from Figure 6, the means designed to indicate to the user the load which can be lifted by the crane 10, that is to say, by the arm 12 of the crane 10, comprise respective means 28, in particular including, or in the form of

corresponding, software means, which are designed to create a table which, for each angular position of rotation, associates with the respective number of sliding members 121 in the extended condition the relative maximum load value which can be lifted, in particular as a function of the configuration of the stabilising means 14 of the crane 12.

**[0051]** Preferably, the means which are designed to indicate to the user the load which can be lifted by the crane 10, that is to say, by the arm 12 of the crane 10, comprise respective means, in particular including or in the form of corresponding software means, which are designed to display, on the display unit 15, in particular of the crane, that is, in the respective area 181 of this, for the respective angular position of the arm indicated in the respective area 182, the value of maximum load which can be lifted that can be associated to the respective number of sliding members 121 in the extended condition, with the values of maximum load which can be lifted which are taken from the table created in the step 28.

**[0052]** Advantageously, as may be inferred from Figures 3 to 5, the means for displaying in succession, on the display means 15 of the crane 10, the values of maximum load which can be lifted by the crane 10, in particular as a function of the number of sliding members 121 of the arm 12 which are in the extended condition, at respective angular positions of rotation 182 of the arm 12, the displaying means comprising respective key means 165, in particular in the form of key means of the remote control unit 16, in particular which increase, for example by 10° degrees each time, the respective screens which display the respective values of maximum load which can be lifted by the crane 10.

**[0053]** In this way, by progressively displaying the various screens which illustrate the maximum loads which can be lifted by the crane, in particular in the various positions of extension of the arm, along a respective angular range, if necessary along the entire angular arc of 360° around the crane, the user can immediately understand which actions may be undertaken to lift the load in a suitable manner.

**[0054]** More specifically, as illustrated, there are means for activating the respective sliding member 121 of the arm 12 of the crane 10 relative to the adjacent sliding member between a respective retracted position relative to the latter and a respective extended position relative to the adjacent sliding member, in particular in the form of corresponding hydraulic drive means, in particular in the form of respective hydraulic jacks.

**[0055]** More specifically, as illustrated, although not illustrated in detail in the accompanying drawings, there are drive means for rotating the telescopic arm 12 relative to the axis of rotation P perpendicular to the crane 12.

**[0056]** More specifically, as illustrated, although not illustrated in detail in the accompanying drawings, there are drive means for inclining the telescopic arm 12 in respective inclined positions, in particular in the form of corresponding hydraulic drive means.

**[0057]** More specifically, as illustrated, although not illustrated in detail in the accompanying

drawings, there are drive means for the sliding members 142 which carry the stabilising means for resting on the ground 141, in particular in the form of corresponding hydraulic drive means, preferably in the form of respective hydraulic jacks.

**[0058]** In practice, as is evident, the technical features described above allow the present invention, individually or in respective combination, to achieve one or more of the following advantageous results:

- it is possible to immediately inform the personnel regarding the operating capacity of the apparatus and it is therefore possible to operate in complete safety.
- the user can immediately understand the current working condition;
- a crane can be provided which is particularly reliable;
- a crane can be provided which makes it possible to operate in a particularly fast manner;
- a crane can be provided which is easy to use;
- a crane can be provided which allows the user to foresee which manoeuvres are to be performed.

**[0059]** The invention described above is susceptible of industrial application. It would be obvious to one skilled in the art that several changes and modifications can be made to the invention without departing from the scope of the invention, which is defined solely by the appended claims.

## **REFERENCES CITED IN THE DESCRIPTION**

This list of references cited by the applicant is for the reader's convenience only. It does not form part of the European patent document. Even though great care has been taken in compiling the references, errors or omissions cannot be excluded and the EPO disclaims all liability in this regard.

### **Patent documents cited in the description**

- US2017036894A [0008]
- WO2017135382A [0015]
- US4211332A [0015]
- US6170681B [0015]

**Patentkrav**

**1.** Kran (10) til at flytte laster (13), omfattende en arm (12) til at støtte lasten (13), hvilken arm kan bevæges teleskopisk i en flerhed af forlængelsespositioner inkluderet mellem en tilbagetrukket position og en position med maksimal  
5 forlængelse og en flerhed af glideelementer (121); idet støttearmen (12) kan roteres i en vinkel, især horisontalt, i forhold til en respektiv rotationsakse (P) af kranen (12), og den kan positioneres i forskellige rotationsvinkelpositioner; idet kranen (10) også omfatter organer (14) hvilke er designet til at stabilisere kranen (12) for at undgå risikoen  
10 for at vælte under driften af armen (12), idet stabiliseringsorganerne (14) kan konfigureres i en flerhed af stabiliseringskonfigurationer af kranen (12); indikatororganer (18) hvilke er designet til at indikere, især til brugeren af kranen (10), den maksimale last, som kan løftes af kranens (10) arm (12), som en funktion af armens (12) forlængelsestilstand og/eller den respektive  
15 rotationsvinkelposition af armen (12); organer (16) til at styre kranens (10) lastbevægelsesarm (12);

- indikatororganerne (18) er placeret ved kranens (12) styreorganer (16);

**kendetegnet ved, at**

- indikatororganerne (18) omfatter en respektiv skærmside, på en  
20 tilsvarende displayenhed (15) af kranen (12), idet skærmsiden omfatter symboler (180), som indikerer antallet af glideelementer (121), som er i en forlænget tilstand;
- skærmsiden omfatter en flerhed af zoner (181), især placeret ved symbolerne, især ved siden af symbolerne (180), hvor den respektive  
25 værdi af den maksimale last i den respektive forlængelsestilstand af kranens (10) arm (12) er indikeret eller vist;
- der er organer på kranens (10) displayorganer (15) til i rækkefølge at vise værdierne af maksimal last som en funktion af armens (12) antal af glideelementer (121), som er i den forlængede tilstand, ved respektive  
30 rotationsvinkelpositioner (182) af armen (12), idet displayorganerne omfatter respektive nøgleorganer (165);
- skærmsiden omfatter et område (182), hvor den respektive rotationsvinkelposition indikerer, eller viser, værdierne af den maksimale last, som kan løftes (181).

**2.** Kranen ifølge krav 1, hvor organerne (18), som indikerer den maksimale last, som kan løftes, er i form af organer, som viser den maksimale last, som kan løftes.

5

**3.** Kranen ifølge et hvilket som helst af de foregående krav, hvor kranenes (10) styreorganer omfatter en displayenhed (15) designet til at definere skærmorganerne (18) og omfatter respektive manuelle styreorganer, især i form af betjeningsknapper og/eller respektive styrestænger (160), som på en passende  
10 måde kan betjenes af brugeren.

**4.** Kranen ifølge krav 3, hvor styreorganerne (16) er i form af en fjernstyringsindretning, især bærbar, med en displayenhed (15).

15 **5.** Kranen ifølge et hvilket som helst af de foregående krav, hvor skærmorganerne, især progressivt, for den respektive rotationsvinkelposition (182) indikerer den maksimale last, som kan løftes, som en funktion af antallet af armens (12) glideelementer (121), som er i den forlængede tilstand.

20 **6.** Kranen ifølge et hvilket som helst af de foregående krav, hvor der er elektroniske behandlingsorganer, som implementerer et tilsvarende program eller software, som er designet til at bestemme eller beregne den maksimale last som en funktion af armens (12) forlængelsestilstand og/eller den respektive rotationsvinkelposition af armen (12).

25

**7.** Kranen ifølge krav 6, hvor organerne, som er designet til at bestemme, eller beregne, den maksimale last, omfatter respektive organer (22), som måler den specifikke konfiguration af kranens (12) stabiliseringsorganer (14), i den respektive drift, især er konfigurationen defineret af den respektive tilstand eller  
30 forlængelsespositionen af glideelementerne (142) til at støtte organerne (141) af stabiliseringsorganerne (14), som hviler på jorden.

**8.** Kranen ifølge krav 7, hvor organerne (22) designet til at måle konfigurationen af stabiliseringsorganer (14) omfatter sensororganer, som er designet til at måle  
35 forlængelseslængden af glideelementerne (142), som bærer de respektive

organer (14), som hviler på jorden.

**9.** Kranen ifølge et hvilket som helst af de foregående krav, hvor:

- 5 - skærmorganerne omfatter respektive softwareorganer eller programinstruktioner, som er designet til at beregne stabilitetsgrænsen punkt for punkt omkring kranen (10), som en funktion af konfigurationen af organerne (14) til at stabilisere kranen (12);
- 10 - softwareorganerne er designet til at skabe en tabel, som, for hver rotationsvinkelposition af armen, forbindes med det respektive antal glideelementer (121) i den forlængede tilstand for den relative maksimale last, som kan løftes, især som en funktion af konfigurationen af kranens (12) stabiliseringsorganer (14);
- 15 - stabiliseringsorganerne (14) omfatter et eller flere elementer, eller fødder, til at hvile på jorden, (141), som hver respektivt kan positioneres i en flerhed af stabiliseringspositioner af kranen (12), mellem en respektiv position tæt på kranen (12), eller køretøjet (11), som støtter kranen (12), og en position længst væk fra kranen (12), eller køretøjet (11) til at støtte kranen (12).

20 **10.** Kranen ifølge et hvilket som helst af de foregående krav, hvor armen (12) til at bevæge lasten (13) kan positioneres i respektive hældningspositioner mellem en maksimal vinkel- eller hældningsposition, hvor armen (12) kan nå den maksimale højde til at bevæge lasten (13), og en mindste vinkel- eller hældningsposition, hvor armen (12) kan nå den mindste højde til at bevæge  
25 lasten (13).

**11.** Kranen ifølge et hvilket som helst af de foregående krav, hvor hvert glideelement (121) er bevægeligt, især glidelig, i forhold til det tilstødende glideelement mellem en respektiv tilbagetrukket position i forhold til det  
30 tilstødende glideelement (121) og en respektiv forlænget position i forhold til det tilstødende glideelement (121), til respektivt at forlænge og trække armen (12) tilbage.

**12.** Kranen ifølge et hvilket som helst af de foregående krav, hvor der er organer  
35 til at aktivere det respektive glideelement (121) af armen (12) på kranen (10) i

forhold til det tilstødende glideelement mellem en respektiv tilbagetrukket position i forhold til sidstnævnte og en respektiv forlænget position i forhold til det samme tilstødende glideelement, i form af respektive hydrauliske donkrafte.

5 **13.** Kranen ifølge et hvilket som helst af de foregående krav, hvor der er drivorganer til at rotere teleskoparmen (12) i forhold til rotationsaksen (P) vinkelret på kranen (12).

10 **14.** Kranen ifølge et hvilket som helst af de foregående krav, hvor der er drivorganer til at vippe teleskoparmen (12) i respektive hældningspositioner, i form af tilsvarende hydrauliske drivorganer.

15 **15.** Kranen ifølge et hvilket som helst af de foregående krav, hvor der er drivorganer til glideelementerne (142), som bærer stabiliseringsorganerne, som hviler på jorden (141), i form af respektive hydrauliske donkrafte.

# DRAWINGS

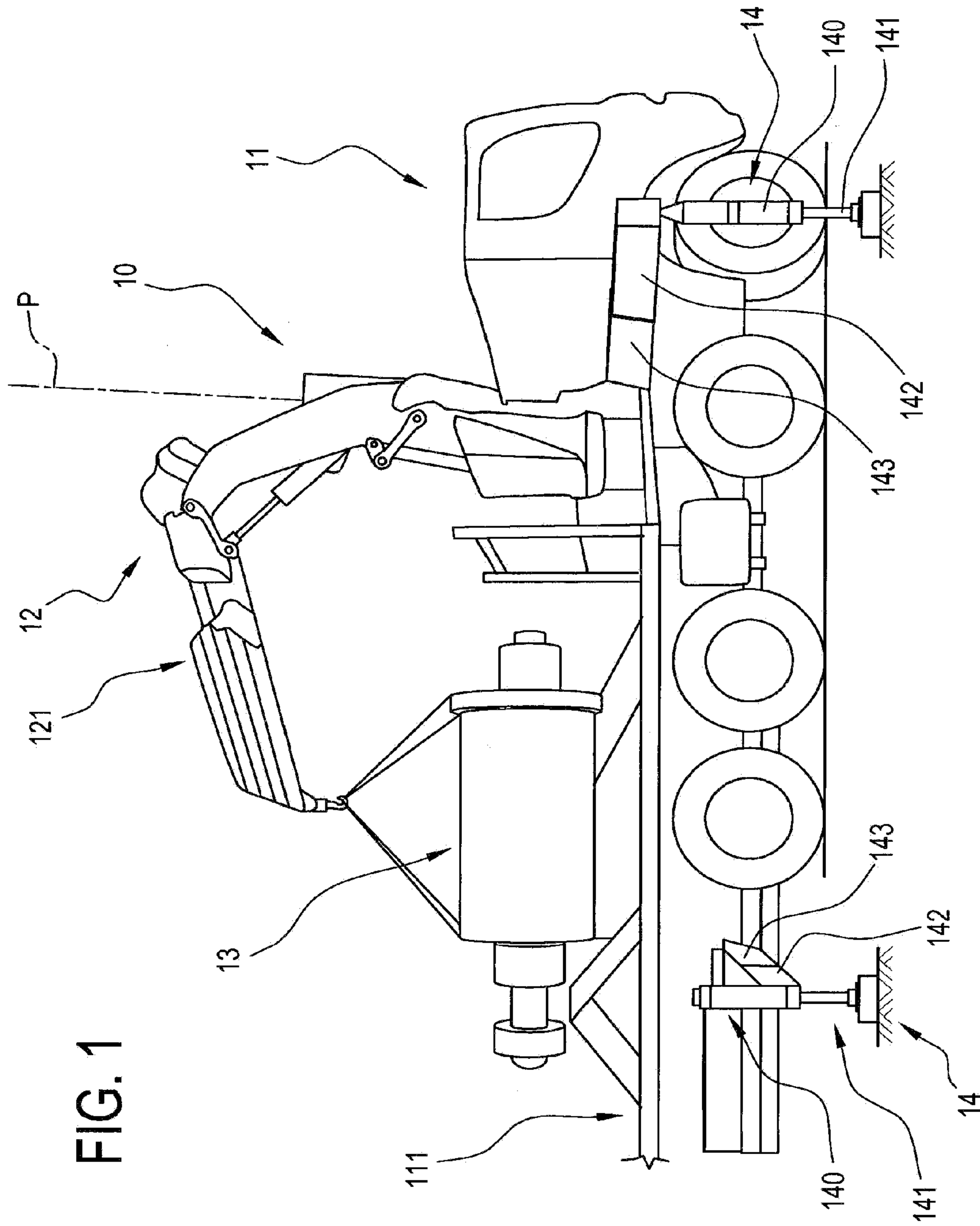

FIG. 2

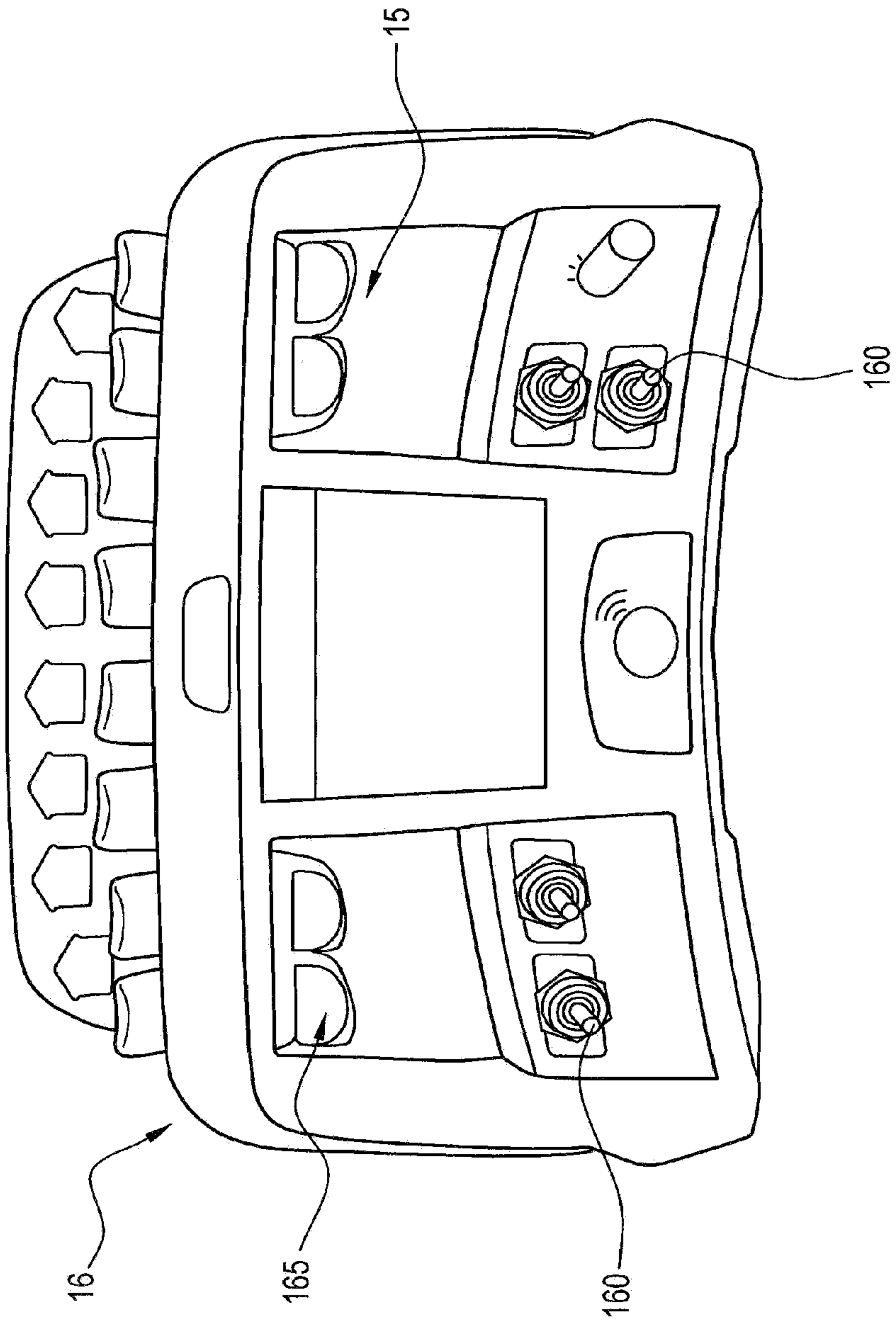

FIG. 3

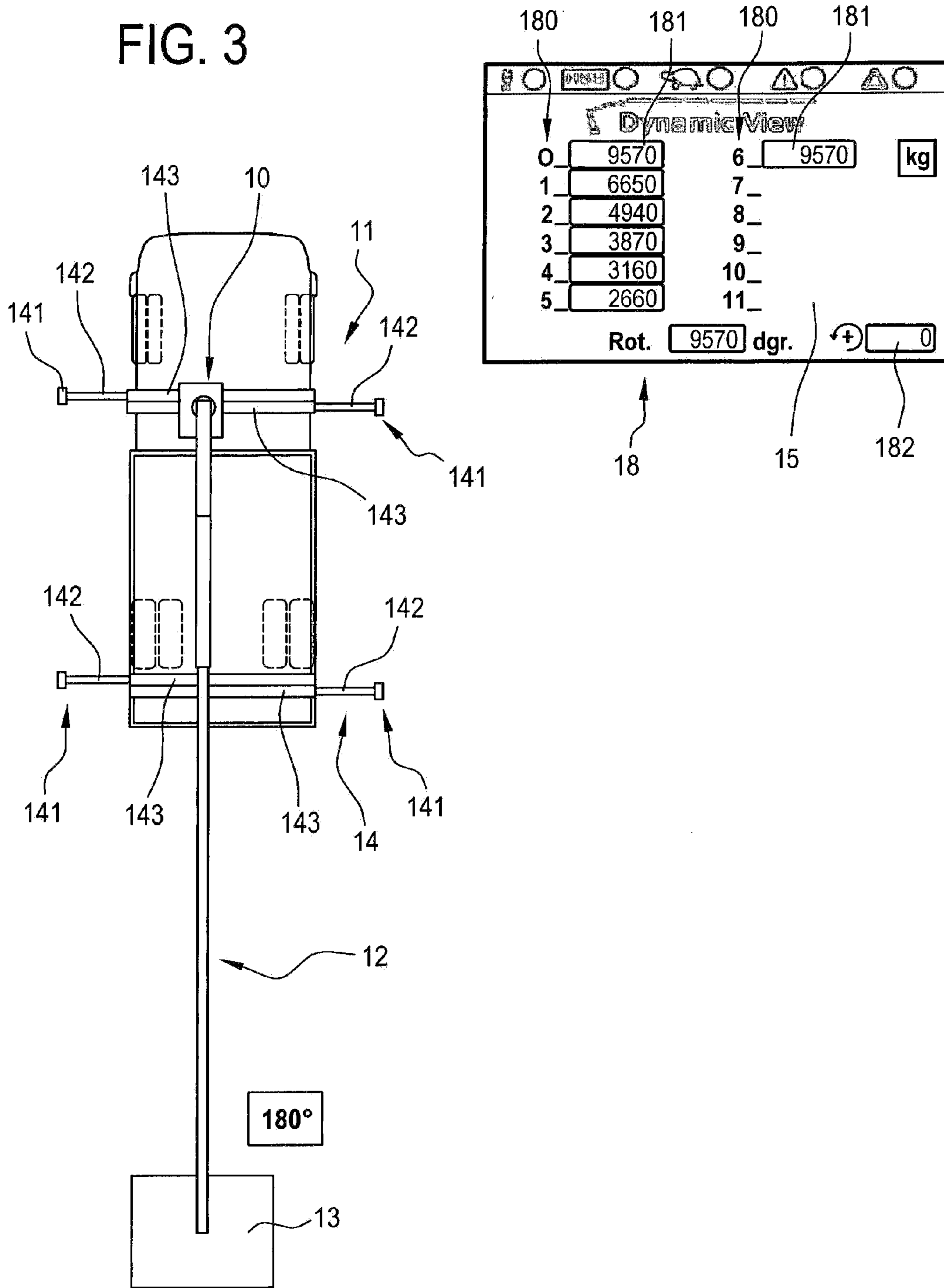

FIG. 4

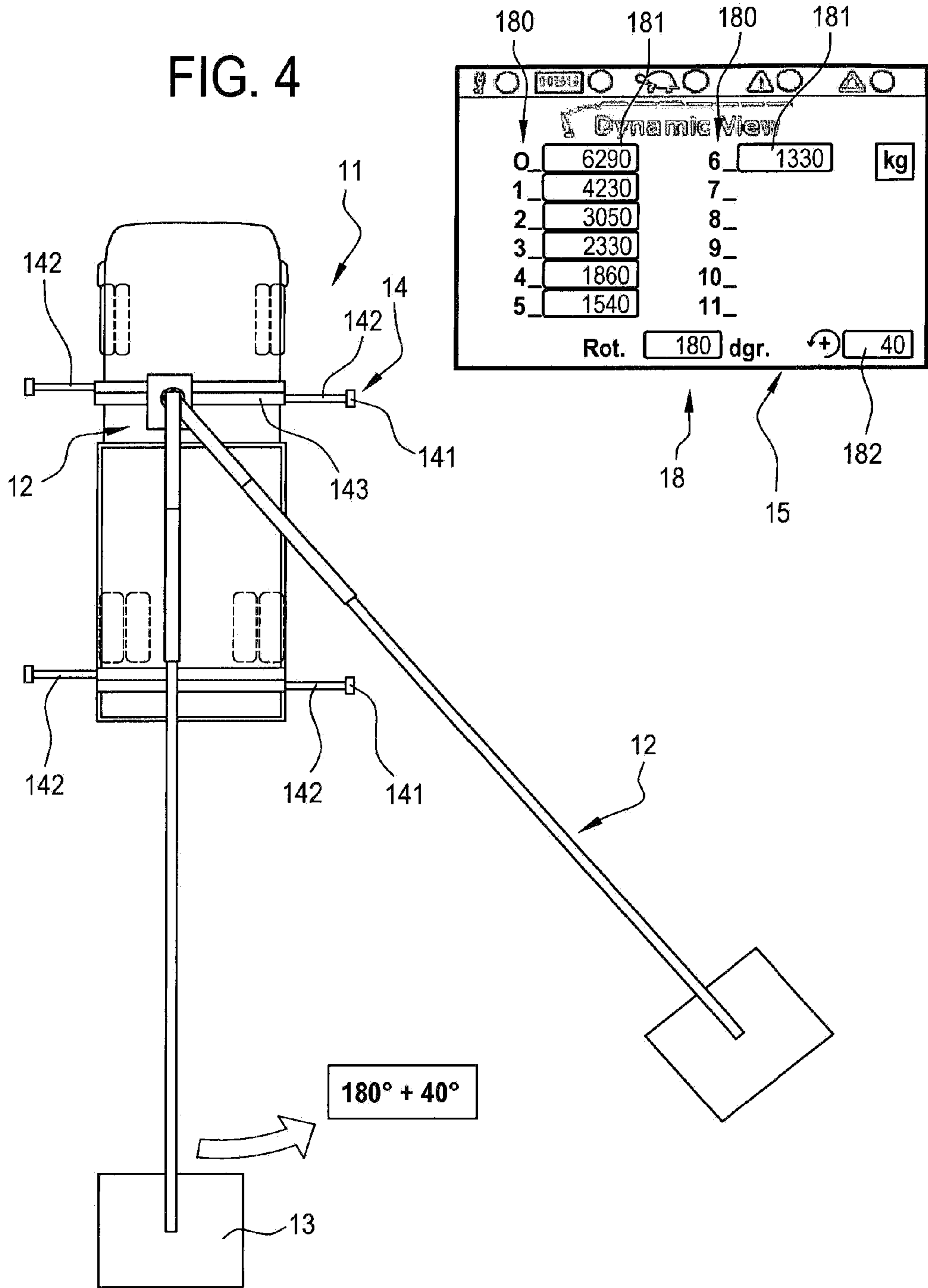

FIG. 5

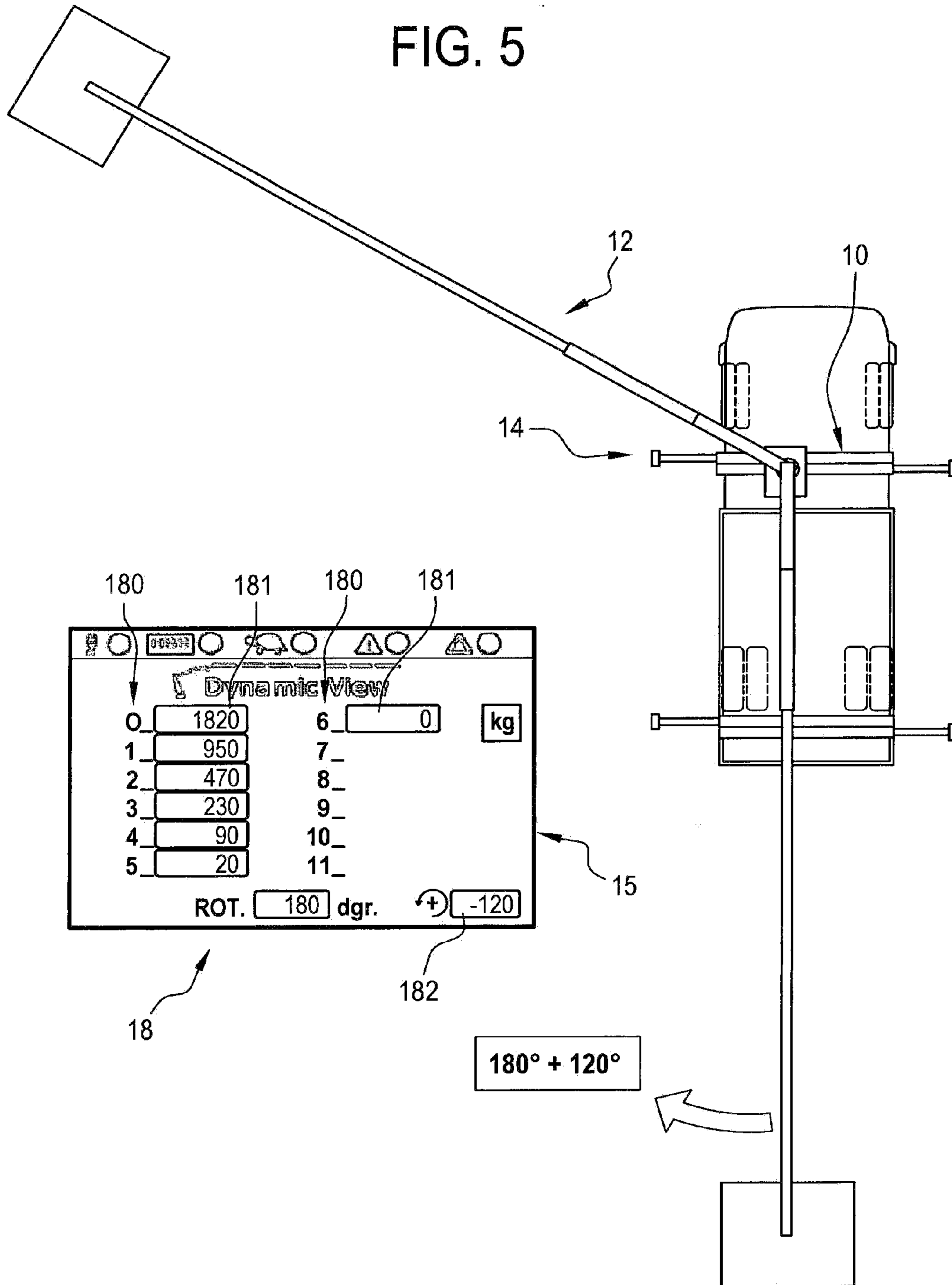

FIG. 6

