

July 9, 1935.

Y. KIDA

2,007,498

METHOD OF ERECTING AN IRON FRAME BUILDING HAVING DEEP UNDERGROUND FLOORS

Filed Jan. 22, 1932

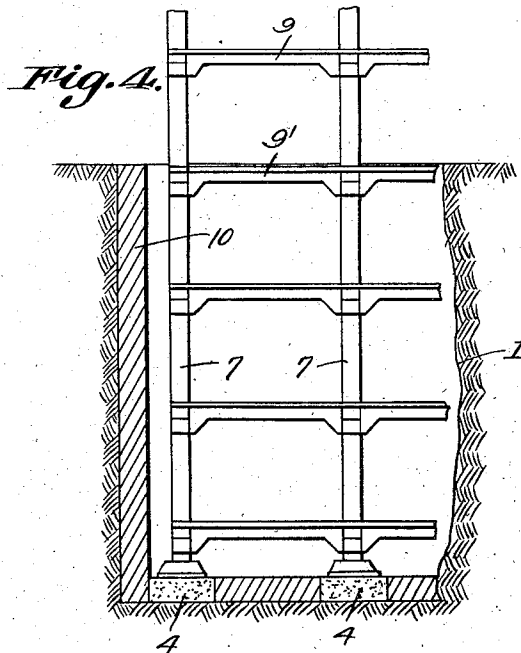
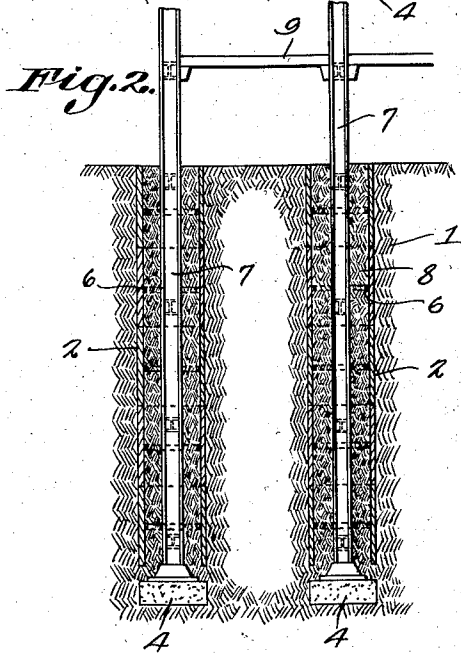
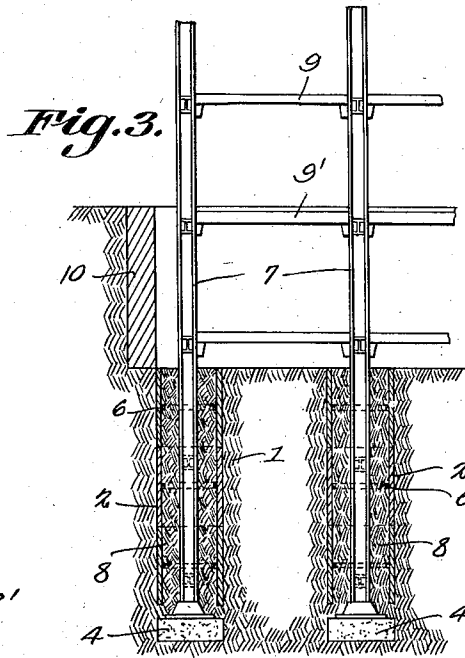
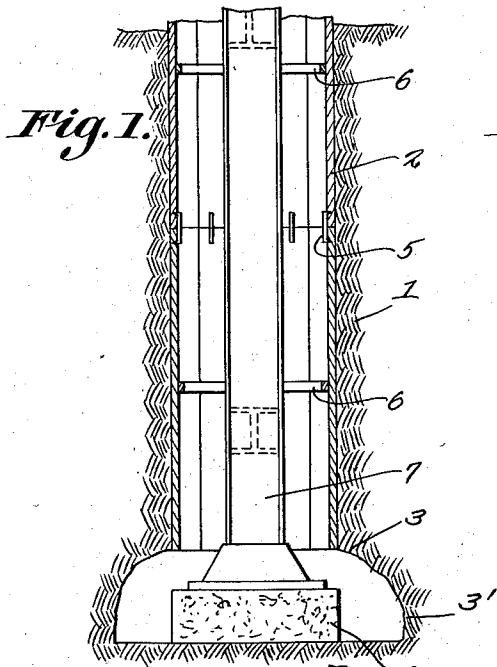

Inventor

Yasuzo Kida  
B. Singer

By

Attorney

# UNITED STATES PATENT OFFICE

2,007,498

## METHOD OF ERECTING AN IRON FRAME BUILDING HAVING DEEP UNDERGROUND FLOORS

Yasuzo Kida, Tokyo, Japan

Application January 22, 1932, Serial No. 588,194

1 Claim. (Cl. 61—50)

This invention relates to a method of erecting an iron frame building having deep underground floors, and consists in first forming a plurality of pits at predetermined intervals, forming a foundation at the bottom of each of said pits, planting a steel pier on said foundation in each pit, extending said steel pier upwardly to protrude above the ground surface while preventing any inclination of the pier by filling up the pit with earth and sand, framing frames for the second and first floors, then excavating the area surrounded by the outermost series of said piers while forming retaining walls on the side wall of said excavated area to prevent any derangement of the soil, then framing successively the frames for underground floors, then forming the frames for remaining upper floors, and then effecting brick or concrete work in a usual manner.

The object of the invention is to erect iron frame buildings having deep underground floors in a simple and economical manner.

In the accompanying drawing which illustrates this invention,

Figure 1 is a sectional view showing one of the pits on the bottom of which is planted a steel pier;

Figure 2 is a sectional view showing two of said pits in which piers are extended above the ground surface, and with the second floor frame erected;

Figure 3 is a sectional view showing a portion of the soil and the frame, in which the area surrounded by outermost series of piers has been excavated approximately halfway downwardly and an underground floor frame has been erected; and

Figure 4 is a sectional view showing a portion of the completed underground frames.

In carrying the present invention into effect, the earth is excavated at intervals to form a plurality of pits 3. Each pit 3 is enlarged at its bottom 3', where a plurality of piles are driven into the ground in a suitable manner, and a rigid foundation 4 is formed using a mixture of concrete mortar and gravels. Upon said foundation 4 is planted a steel pier or beam 7. The pier 7 is extended by joining other piers so as

to extend above the ordinary surface of the ground, the space around the pier 7 being successively filled up with earth and sand 8 in order to prevent any inclination of the pier 7. Connecting the piers 7 erected in the above mentioned operation, beams 9 and 9' for the second and first floors are framed at suitable levels. Then, the area 1 surrounded by the outermost series of piers is excavated, and the sides of the excavated area are protected by retaining walls 10 so as to prevent any destruction by slip of the soil. As the operation of excavation proceeds the floor beams for every underground floor are framed, and the retaining wall is also extended downwardly, as shown in Fig. 4. After completing the framing of the underground floors, the framing of the upper floors is proceeded successively upwardly, and then suitable brick or concrete work is carried out in a usual manner.

In the drawing, 2 designates the inner wall or lining of the pits 3. 5 are clamps joining plates forming said wall 2.

In practice, the usual method of sinking a well may be conveniently adopted for forming the pit 3 and enlarging the bottom of the pit.

What I claim is:—

The herein described method of erecting an iron frame building having deep underground floors, consisting in forming pits at spaced intervals within the outline of the base of the building, forming a foundation at the bottom of each pit, lining the pits, planting the required number of piers of predetermined length on the foundations in the pits, and while doing so simultaneously filling up the pits with material such as earth to prevent inclination of the piers, excavating the area surrounding the pits and forming the outline of the base of the building, simultaneously constructing a retaining wall in the sides of such excavation, continuing such excavation and retaining wall construction to a depth corresponding to that of the pier foundations and simultaneously forming the framings of the underground floors and removing the said pit linings and fillings.

YASUZO KIDA.