

J. BORRO.  
 SAFETY ENVELOP.  
 APPLICATION FILED MAR. 15, 1916.

1,195,773.

Patented Aug. 22, 1916.

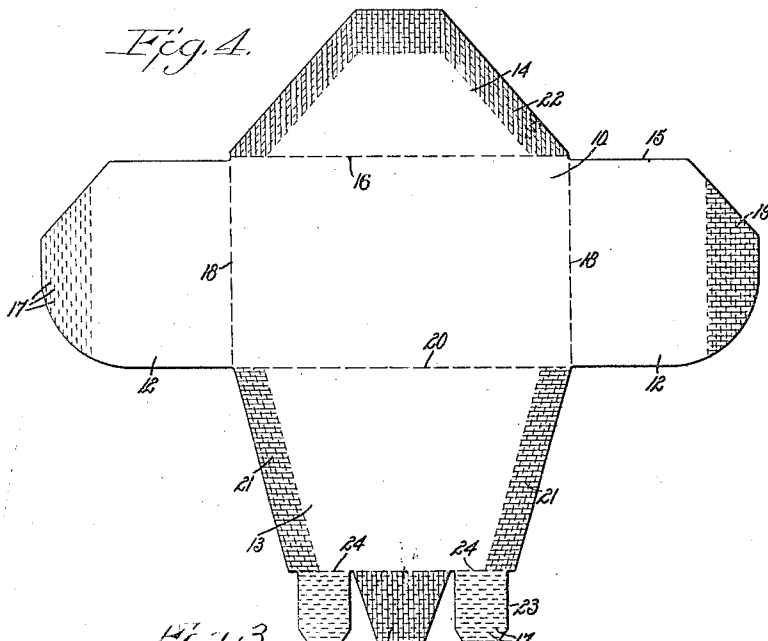
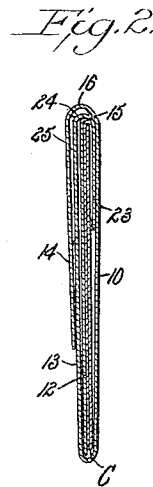
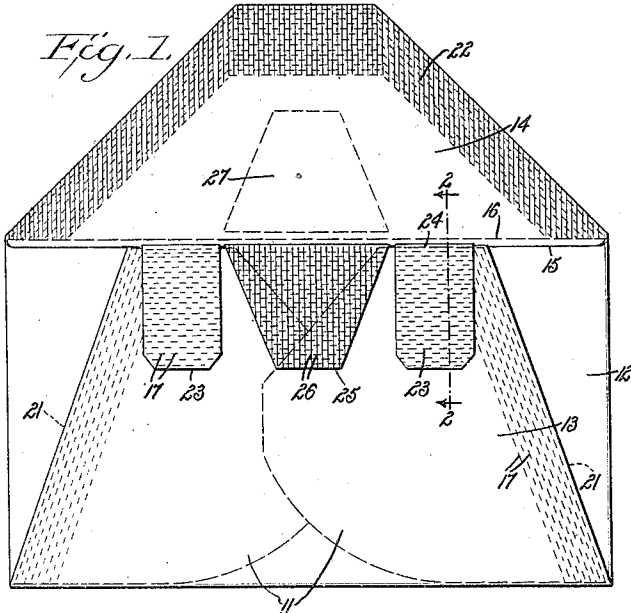

WITNESSES

*Oliver W. Holman*  
*John Beeson*



INVENTOR  
*J. Borro*

BY *Munroe & Co.*  
 ATTORNEYS

# UNITED STATES PATENT OFFICE.

JOSEPH BORRO, OF NEW YORK, N. Y.

SAFETY-ENVELOP.

1,195,773.

Specification of Letters Patent. Patented Aug. 22, 1916.

Application filed March 15, 1916. Serial No. 84,315.

*To all whom it may concern:*

Be it known that I, JOSEPH BORRO, a citizen of the United States, and a resident of the city of New York, borough of Manhattan, in the county and State of New York, have invented a new and Improved Safety-Envelope, of which the following is a full, clear, and exact description.

This invention relates to stationery and has particular reference to envelopes or other analogous wrappers for letters or the like.

Among the objects of the invention is primarily to provide an envelop of such a nature that it is practically impossible for it to be surreptitiously opened without detection. By the term "envelop" as used hereinafter, for the sake of simplicity of description, I wish to be understood as covering any analogous wrapper for mailing or like purposes.

Another object of the invention is to provide an improved form of envelop which will automatically hold the contents of the letter spaced from the line along which an ordinary letter-opening machine operates, whereby it is practically impossible for said contents to be damaged while the envelop is being opened.

With the foregoing and other objects in view, the invention consists in the arrangement and combination of parts hereinafter described and claimed, and while the invention is not restricted to the exact details of construction disclosed herein, still for the purpose of illustrating a practical embodiment thereof reference is had to the accompanying drawings, in which the reference characters designate the same parts in the several views, and in which—

Figure 1 is a rear elevation of an envelop made in accordance with this invention, the same being shown as in position to receive the letter; Fig. 2 is a vertical transverse section of a letter sealed in this improved envelop, the parts being in the position they would occupy with the sealing flap drawn forwardly toward the observer in Fig. 1, and the section being so taken as to look toward the left from the line 2—2; Fig. 3 is a plan view of the device shown in Fig. 1, the main sealing flap being still open but with the locking flaps introduced into or toward their final position within the envelop; and Fig. 4 is a plan view of the blank from which the envelop is formed.

Referring now more particularly to the drawings, I show an envelop comprising a

front panel 10, a back panel 11 formed by the connection of the end flaps 12 and bottom panel 13, and a main sealing flap 14. The general design of the envelop formed as thus far described may be variously arranged, according to the size or shape of the envelop, but it will be noted especially from Fig. 1 that when the back panel 11 is formed by the connection of the end and bottom flaps, its upper edge, as indicated at 15, lies spaced downwardly or inwardly from the folding line 16 or hinge for the sealing flap 14 for a purpose that will appear presently.

In the manufacture of the envelop, all portions thereof that are intended to be glued to other portions are punctured or perforated, as indicated at 17, throughout the gummed surface. The perforating is indicated in the drawings by parallel dash lines and the gumming is indicated by parallel full lines.

Beginning with the blank, as shown in Fig. 4, the end flap 12 at the left is folded inwardly around its folding line 18, and then the similar flap 12 at the right is likewise folded inwardly around its folding line 18, and the gum at 19 is then moistened or applied, securing the tip ends of the end flaps together. The bottom flap 13 is then folded upward around the line 20 and the gum is moistened or applied along the edges 21 whereby the flap 13 is secured upon the outer surfaces of the previously folded end flaps 12. The sealing flap 14 obviously is left open until the envelop is to be used, but is provided with gum as usual along the line or margin 22. With all of the gummed or interlocked portions minutely perforated as shown and described, it is a practical physical impossibility for the envelop to be opened by the use of an instrument, by steaming, or otherwise, without the addressee being appraised of the fact. The perforated paper is so easily torn that in order to open the envelop surreptitiously, such opening cannot be effected and the envelop again sealed without the fact being shown upon the envelop itself.

Another feature of improvement and advantage is the use of one or more inwardly turned locking flaps or tongues 23 shown as being formed integral with the free edge of the bottom flap 13. These tongues are shown as two in number and arranged adjacent the free corners of the bottom flap 13. These tongues are punctured to pro-

vide the perforations 17 already described, and are gummed on the outside or on the side opposite from the lines of gum at 21. See Fig. 3. In the finished envelop, as prepared for the market, or in the condition in which the letter is introduced thereinto, the tongues 23 project loosely from their lines of connection 24 on the outside of the envelop. When the letter is introduced, these 10 tongues are folded inwardly over the letter, and the gum on the outer surfaces thereof being moistened causes the outer faces of the tongues to adhere firmly to the inner face of the front panel 10, as shown in Fig. 15 2. These tongues, therefore, serve two functions, first, to hold the contents of the letter indicated at C, spaced downwardly a material distance, say, one-eighth of an inch or so below the line 16, so that a letter-opening machine may be operated safely along said line 16 without any possibility of cutting or damaging the contents of the letter. The second function of these tongues is to render it still more improbable that the envelop may be opened without authority and without detection.

Between the locking tongues 23 is formed a sealing tongue 25 formed as an integral part of the bottom flap 13, and for the sake of economy of material it may be of the same length as the tongues. Like the tongues it is left free during the manufacture of the envelop. It, however, is 30 gummed as indicated at 26, on its inner face or upon the face opposite from the gummed faces of the tongues 23. After the letter is introduced, as shown at C in Fig. 2, and the locking tongues are moistened and inserted into locking position, the final sealing operation is made. This consists in moistening the gum along the margin 22 along the main sealing flap 14 and also the gum 26 upon the then exposed face of the sealing tongue 25. The sealing tongue being in the 45 position shown in Fig. 1 will be otherwise undisturbed, and the sealing flap 14 will be brought down into final position, causing the sealing tongue to adhere firmly upon the inner surface of the sealing flap at the spot indicated at 27 by dotted lines in Fig. 1. Since the sealing tongue is punctured also throughout its surface, it will be apparent that the envelop thus formed and sealed is 50 positive proof against tampering.

55 I claim:—

1. In a safety envelop, the combination of front and rear panels, a sealing flap formed as an extension of the front panel and foldable around a folding line over the 60 outer surface of the rear panel, and means

carried by the rear panel below said folding line of the sealing flap and gummed to adhere firmly against the inner surface of the front panel whereby the contents of the letter are held spaced from said folding 65 line.

2. In a safety envelop, the combination of front and rear panels, a sealing flap extending from the upper edge of the front panel and foldable along a line bounding 70 the upper edge of the front panel, the rear panel having its upper edge substantially parallel to but spaced downwardly from said folding line, and a pair of spaced tongues formed as integral parts of the rear 75 panel and projecting from said upper edge thereof, said tongues being foldable inwardly and downwardly over the contents of the letter and gummed to adhere firmly to the inner surface of the front panel 80 whereby said contents are held downwardly spaced from the folding line of the sealing flap.

3. In a safety envelop, the combination of front and rear panels, a sealing flap fold- 85 able from the front panel over the outer surface of the rear panel, a locking tongue formed as an integral part of the rear panel and foldable thence inwardly over the contents of the letter and gummed to stick 90 firmly against the inner surface of the front panel, and a sealing tongue formed as another integral part of the rear panel and gummed to adhere firmly against the inner surface at the central part of the sealing 95 flap when the latter is brought into sealing position.

4. In a safety envelop, the combination of a front panel, end flaps foldable over the front panel and overlapping each other, a 100 rear panel foldable over the end flaps and gummed on the outside thereof, a pair of spaced locking tongues formed as integral parts of the rear panel and foldable thence 105 inwardly over the contents of the letter and gummed to stick firmly against the inner surface of the front panel, a sealing tongue formed as another integral part of the rear panel between the locking tongues aforesaid and foldable outwardly to lie against the 110 outer face of the rear panel, and a sealing flap carried by the front panel and foldable over the sealing tongue aforesaid and rear faces of the end flaps and rear panel, said sealing tongue being gummed to adhere to the inner face of the sealing flap. 115

JOSEPH BORRO.

Witnesses:

BARTHOLOMEW SBARBORO,  
MICHAEL BALLETO.