

R. R. PIPER.
Pipe-Wrench.

No. 219,758.

Patented Sept. 16, 1879.

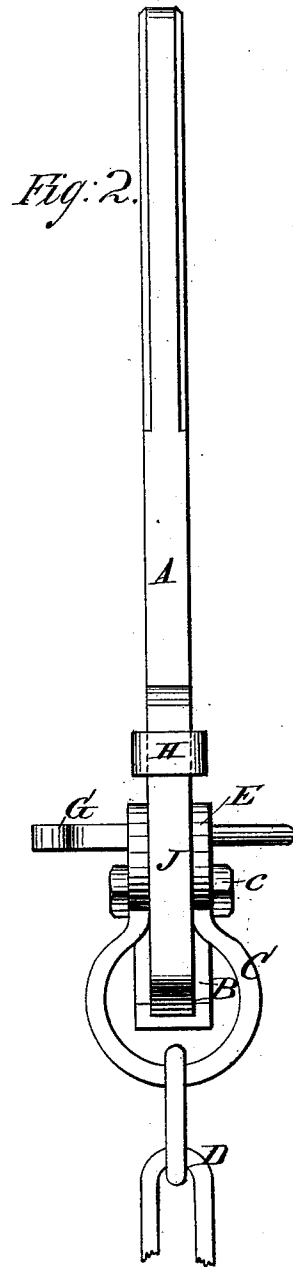
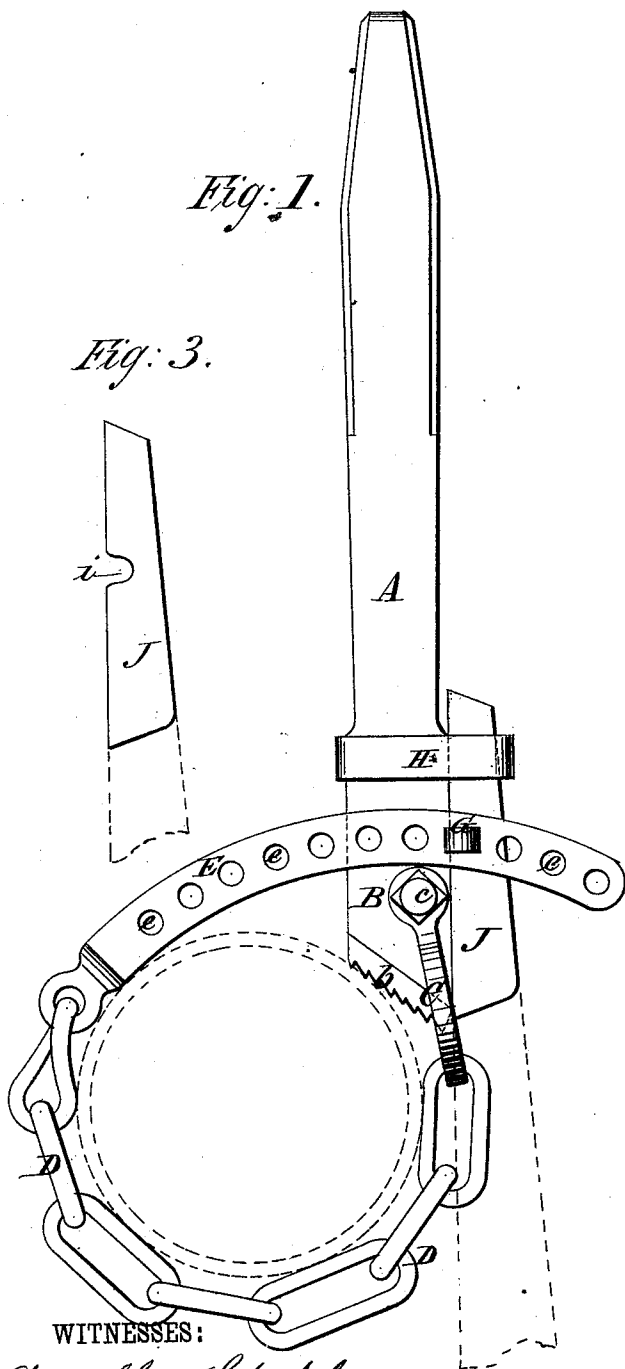

WITNESSES:

Achilles Schehl.
C. Senywick

INVENTOR:

R. R. Piper

BY

Munnick
ATTORNEYS.

UNITED STATES PATENT OFFICE.

ROYAL R. PIPER, OF EAST SAGINAW, MICHIGAN.

IMPROVEMENT IN PIPE-WRENCHES.

Specification forming part of Letters Patent No. 219,758, dated September 16, 1879; application filed March 12, 1879.

To all whom it may concern:

Be it known that I, ROYAL R. PIPER, of East Saginaw, in the county of Saginaw and State of Michigan, have invented a new and useful Improvement in Pipe-Wrenches, of which the following is a specification.

My invention relates to that class of pipe-wrenches in which a chain is employed in connection with a serrated jaw and a handle or lever.

The invention consists in a novel construction, combination, and arrangement, with relation to each other, of the jaw and its handle or lever, the chain, and a perforated curved bar attached thereto, and locking and fastening devices connected therewith, whereby provision is made for adjusting the wrench to suit pipes of different sizes, and for insuring the proper engagement and operation of the parts when in use.

In the accompanying drawings, Figure 1 represents a side view of a wrench embodying my improvements. Fig. 2 is an edge view of the same. Fig. 3 is a detail view.

Similar letters of reference indicate corresponding parts.

The handle or lever A may be of any suitable length, and in one piece with the jaw B, the biting surface or face of which is inclined at a suitable angle, and furnished with serrations *b*.

A short distance above the serrations is a hole, through which passes a bolt, *c*, which holds in place a swinging link or stirrup, C. To this link or stirrup is attached one end of a chain, D, to the other end of which is attached a bifurcated curved bar, E, in which are perforations *e*, for the reception of a locking-pin, G.

On the jaw B, at or near the point where the handle begins, is a loop or keeper, H, which receives the smaller end of a tapering or wedge-

shaped key, J. This handle (see Fig. 3) has on one side a notch, *i*, of a size suitable for the engagement of the locking-pin G.

The pin G is split and elastic, so that when in position in the perforations *e* the split ends will spring outward and prevent it from being accidentally displaced.

In using this wrench the serrated surface of the jaw B is placed against the surface of the pipe to be turned, as shown in dotted lines, and the chain D is passed around said pipe. The perforated curved bar E is then placed so that its two branches will pass on either side of the jaw B, below the loop or keeper H. The key J is then placed in position, lying against the edge of the jaw B between the two branches of the bar E, with the smaller end of the handle inserted in the loop or keeper H. The locking-pin G is then passed through the perforations *e*, and also through the notch *i* of the key J. By this means the parts are held firmly in position and prevented from displacement; and when the handle is moved to turn the pipe the serrated jaw is enabled to take a firm hold, and is effectually prevented from slipping.

When it is desired to use this wrench on galvanized or polished surfaces, a strip of leather or other material may be interposed between it and the work, in order to prevent the marring of the surface.

Having thus described my invention, I claim as new and desire to secure by Letters Patent—

The combination of the correspondingly-notched handle A and key J, the bolt *c*, chain D, perforated bar E, and loop H, as shown and described.

ROYAL R. PIPER.

Witnesses:

A. J. DENTON,
J. INGLEHART.