

(19) World Intellectual Property Organization  
International Bureau



(43) International Publication Date  
23 February 2006 (23.02.2006)

PCT

(10) International Publication Number  
**WO 2006/019792 A2**

- (51) International Patent Classification:  
**B09B 1/00** (2006.01)
- (21) International Application Number:  
PCT/US2005/024815
- (22) International Filing Date: 13 July 2005 (13.07.2005)
- (25) Filing Language: English
- (26) Publication Language: English
- (30) Priority Data:  
10/891,396 14 July 2004 (14.07.2004) US
- (71) Applicant (for all designated States except US): **B & P TECHNOLOGIES, INC.** [US/US]; P.O. Box 359, Winfield, MO 63389 (US).
- (72) Inventor; and
- (75) Inventor/Applicant (for US only): **BROWN, James, S.** [US/US]; P.O. Box 359, Winfield, MO 63389 (US).
- (74) Agents: **KEPLER, John, W.III** et al.; Polsinelli Shalton Welte Suelthaus pc, 7733 Forsyth Blvd., 12th Floor, St. Louis, MO 63105 (US).
- (81) Designated States (unless otherwise indicated, for every kind of national protection available): AE, AG, AL, AM, AT, AU, AZ, BA, BB, BG, BR, BW, BY, BZ, CA, CH, CN, CO, CR, CU, CZ, DE, DK, DM, DZ, EC, EE, EG, ES, FI, GB, GD, GE, GH, GM, HR, HU, ID, IL, IN, IS, JP, KE, KG, KM, KP, KR, KZ, LC, LK, LR, LS, LT, LU, LV, MA, MD, MG, MK, MN, MW, MX, MZ, NA, NG, NI, NO, NZ, OM, PG, PH, PL, PT, RO, RU, SC, SD, SE, SG, SK, SL, SM, SY, TJ, TM, TN, TR, TT, TZ, UA, UG, US, UZ, VC, VN, YU, ZA, ZM, ZW.
- (84) Designated States (unless otherwise indicated, for every kind of regional protection available): ARIPO (BW, GH, GM, KE, LS, MW, MZ, NA, SD, SL, SZ, TZ, UG, ZM, ZW), Eurasian (AM, AZ, BY, KG, KZ, MD, RU, TJ, TM), European (AT, BE, BG, CH, CY, CZ, DE, DK, EE, ES, FI, FR, GB, GR, HU, IE, IS, IT, LT, LU, LV, MC, NL, PL, PT,

[Continued on next page]

(54) Title: MEDICAL WASTE DISPOSAL DEVICE

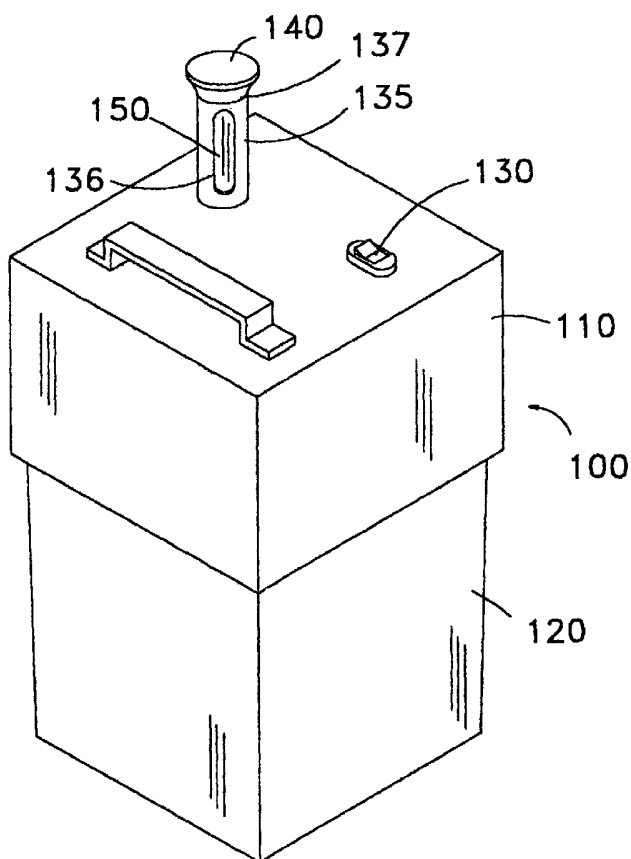

(57) Abstract: A medical waste disposal device (100) having a blade (200) that rotates and chops medical waste (800) into chips and other small particles. The blade (200) includes at least one opening (210) with at least one sharpened edge (250). The blade (200) also has at least one raised portion (270) adjacent to the sharpened edges (250). The blade (200) cooperates with a cutting plate (500) to chop or scissor the medical waste (800). The raised portion (270) pushes chopped medical waste (800) away from the blade (200) and the cutting plate (500).

WO 2006/019792 A2



RO, SE, SI, SK, TR), OAPI (BF, BJ, CF, CG, CI, CM, GA, GN, GQ, GW, ML, MR, NE, SN, TD, TG).

**Declarations under Rule 4.17:**

- as to applicant's entitlement to apply for and be granted a patent (Rule 4.17(ii)) for the following designations AE, AG, AL, AM, AT, AU, AZ, BA, BB, BG, BR, BW, BY, BZ, CA, CH, CN, CO, CR, CU, CZ, DE, DK, DM, DZ, EC, EE, EG, ES, FI, GB, GD, GE, GH, GM, HR, HU, ID, IL, IN, IS, JP, KE, KG, KM, KP, KR, KZ, LC, LK, LR, LS, LT, LU, LV, MA, MD, MG, MK, MN, MW, MX, MZ, NA, NG, NI, NO, NZ, OM, PG, PH, PL, PT, RO, RU, SC, SD, SE, SG, SK, SL, SM, SY, TJ, TM, TN, TR, TT, TZ, UA, UG, UZ, VC, VN, YU, ZA, ZM, ZW, ARIPO patent (BW, GH, GM, KE, LS, MW, MZ, NA, SD, SL, SZ, TZ, UG, ZM, ZW), Eurasian patent (AM, AZ, BY, KG, KZ, MD, RU, TJ, TM), European patent (AT, BE, BG, CH, CY, CZ, DE, DK, EE, ES, FI, FR, GB, GR, HU, IE, IS, IT, LT, LU, LV, MC, NL, PL, PT, RO, SE, SI, SK, TR), OAPI patent (BF, BJ, CF, CG, CI, CM, GA, GN, GQ, GW, ML, MR, NE, SN, TD, TG)
- as to the applicant's entitlement to claim the priority of the earlier application (Rule 4.17(iii)) for the following designations AE, AG, AL, AM, AT, AU, AZ, BA, BB, BG, BR, BW,

BY, BZ, CA, CH, CN, CO, CR, CU, CZ, DE, DK, DM, DZ, EC, EE, EG, ES, FI, GB, GD, GE, GH, GM, HR, HU, ID, IL, IN, IS, JP, KE, KG, KM, KP, KR, KZ, LC, LK, LR, LS, LT, LU, LV, MA, MD, MG, MK, MN, MW, MX, MZ, NA, NG, NI, NO, NZ, OM, PG, PH, PL, PT, RO, RU, SC, SD, SE, SG, SK, SL, SM, SY, TJ, TM, TN, TR, TT, TZ, UA, UG, UZ, VC, VN, YU, ZA, ZM, ZW, ARIPO patent (BW, GH, GM, KE, LS, MW, MZ, NA, SD, SL, SZ, TZ, UG, ZM, ZW), Eurasian patent (AM, AZ, BY, KG, KZ, MD, RU, TJ, TM), European patent (AT, BE, BG, CH, CY, CZ, DE, DK, EE, ES, FI, FR, GB, GR, HU, IE, IS, IT, LT, LU, LV, MC, NL, PL, PT, RO, SE, SI, SK, TR), OAPI patent (BF, BJ, CF, CG, CI, CM, GA, GN, GQ, GW, ML, MR, NE, SN, TD, TG)

- of inventorship (Rule 4.17(iv)) for US only

**Published:**

- without international search report and to be republished upon receipt of that report

For two-letter codes and other abbreviations, refer to the "Guidance Notes on Codes and Abbreviations" appearing at the beginning of each regular issue of the PCT Gazette.

**MEDICAL WASTE DISPOSAL DEVICE**Field Of The Invention

The present invention relates to a medical waste disposal device having a blade that rotates and chops medical waste, such as syringes, into chips and other small particles.

5

Background Of The Invention

Medical waste disposal is a concern for both the medical industry and the sanitation industry. The medical industry creates an enormous amount of medical waste. Moreover, medical waste, such as syringes, catheters, tracheotomy tubes, blades, and surgical needles, may be contaminated with bacteria and/or viruses, and accordingly, proper disposal of the medical waste requires extra measures and steps beyond general waste disposal procedures. Medical waste contaminated with bacteria and/or viruses must be handled carefully by medical providers and sanitation workers to prevent their exposure to the bacteria and/or viruses.

10

Besides concerns regarding contamination, medical waste should be reduced in size to conserve landfill space, to reduce the labor involved in disposing the medical waste, and to reduce the amount of space that medical facilities must dedicate to waste management.

15

Medical waste, when properly sterilized and separated, may also be recycled. Plastics and metal form most of the constituent parts of syringes, catheters, tracheotomy tubes, blades and surgical needles.

20

There have been many attempts in the prior art to provide for a medical waste disposal device that grinds or reduces medical waste. Unfortunately, many of the prior art designs are inoperable or are prone to jamming. Moreover, many of these prior art devices are too large or too expensive to be suitable for an individual hospital room. Other shortcomings in the prior art include a failure to provide for a working and portable medical waste disposal device.

25

As described above, there is a need for a medical waste disposal device that provides for sanitary and efficient operation and further provides the potential for recycling.

Summary Of The Invention

30

Embodiments, including the technical features of the invention for which protection is sought, are illustrated and described herein and include a medical waste disposal device having a blade that rotates and chops medical waste into chips and other small particles. The blade comprises at least one opening with at least one sharpened edge. The blade also has at least one raised portion adjacent to the sharpened edges. The blade cooperates with a cutting plate to chop or scissor the medical waste. The raised portion pushes chopped medical waste away from the blade and the cutting plate. The chopped medical waste is generally forced through the opening in the blade.

It is a further aspect of the present invention to provide a portable medical waste disposal device that operates on direct current.

It is a further aspect of the present invention to provide a medical waste disposal device that reduces contamination.

5 It is still a further aspect of the present invention to provide a medical waste disposal device that significantly reduces the volume of the medical waste and thereby reduces labor costs related to emptying the medical waste disposal device.

These and other aspects of the present invention are achieved herein.

#### Brief Description Of The Drawings

10 The present invention is illustrated by the embodiments shown in the drawings, in which:

FIG. 1 is a view of a medical waste disposal device.

FIG. 2 is a view of the medical waste disposal device with an upper housing separated from a lower housing.

15 FIG. 3 is a view of the upper housing of the medical waste disposal device with a plunger removed to expose an opening in a drop shaft.

FIG. 4 is a view of the upper housing with a lid removed.

FIG. 5 is a view of a top surface of a blade for the medical waste disposal device.

FIG. 6 is a side view of the blade.

FIG. 7 is a cross-section view of the blade.

20 FIG. 8 is a view of a six-opening blade for the medical waste disposal device.

FIG. 9 is a view of a two-opening blade for the medical waste disposal device.

FIG. 10 is a side view of the upper housing with the blade attached.

FIG. 11 is a view of the relationship of the blade to the drop shaft.

FIG. 12 is a close-up view of the relationship between the drop shaft and the blade.

25 FIG. 13 is a bottom view of the upper housing.

FIG. 14 is a close-up view of the bottom of the upper housing.

FIG. 15 is a view showing a cutting mechanism of the present invention.

FIG. 16 is a close-up view of the cutting mechanism of the present invention.

FIG. 17 shows the interaction of a cutting plate and the blade.

30 FIG. 18 is a detailed view of the opening and sharpened edge of the blade.

FIG. 19 is a sectional view showing the cutting mechanism of the present invention.

FIG. 20 is a view of the cyclonic action created by the medical waste disposal device.

FIG. 21 is a view of a compact version of the present invention.

FIG. 22 is a view of the compact version with upper and lower housings separated.

Detailed Description Of The Invention

Referring now to the following description and figures, there are shown preferred embodiments for the medical waste disposal device of this invention, including the technical features of the invention for which protection is sought. The present invention relates to a medical waste disposal device having a blade that rotates and chops medical waste into chips and small particles. The medical waste disposal device reduces the volume of raw medical waste. Also, the medical waste disposal device may include a UV light to render the chips and small particles sterile and innocuous.

The medical waste disposal device of the present invention generally includes a housing. The housing contains the blade and means for rotating the blade safely away from the user. The housing contains the chopped medical waste until it is later disposed. In one preferred embodiment, the housing includes an upper housing and a lower housing. The upper housing includes a motor for rotating the blade. The upper housing also includes a battery for providing electrical power to the motor. Other necessary and customary electrical components and connections are also contained in or supported by the upper housing. Other embodiments may include a liner in the housing that collects the medical waste. The liner may be removed for disposal and replaced with a new liner.

On the exterior of the upper housing, an on/off switch is located for operating the device. The upper housing also includes an opening for a drop shaft and a plunger. The drop shaft provides passage for the medical waste from the exterior of the device to the blade. The plunger contains the medical waste within the drop shaft and within the housing.

The lower housing includes the blade and a space or region to collect the chopped medical waste particles. In some embodiments, an optional UV light may be contained in the lower housing or on a lower portion of the upper housing to disinfect/sterilize the chopped medical waste. In a preferred embodiment, a drive shaft from the motor penetrates the lower housing. The blade is attached to this drive shaft. The drop shaft also connects to the lower housing and has an opening into the lower housing. At the junction of the drop shaft and the lower housing, a cutting plate is provided to act in conjunction and cooperation with the blade in chopping the medical waste. The cutting plate circumscribes at least a portion of the opening of the drop shaft into the lower housing. The cutting plate includes a sharpened edge that operates in conjunction and cooperation with the blade to chop or scissor the medical waste. The sharpened edge of the cutting plate has an angle of approximately  $10^\circ$  to approximately  $90^\circ$ . This angle is shown as angle  $\beta$  in Figure 19. The cutting plate may be integral to the lower housing or may be a separate component attached to the lower housing.

In operation of the medical waste disposal device of the present invention, the operator lifts the plunger and drops the medical waste into an opening in the drop shaft where the medical waste falls in a vertical manner, due to the circumference of the drop shaft, until it contacts the blade where it is chopped by the blade and the cutting plate. An important feature of the present invention is the vertical nature of the drop shaft. This is especially important for medical waste, such as syringes, that are long and narrow. The drop shaft directs a syringe to contact the blade in a vertical manner such that the syringe is chopped in piece-by-piece manner, instead of the entire syringe contacting the blade at an instance. The drop shaft directs the syringe or the medical waste to contact the blade in a manner parallel to the axis of rotation of the blade, and thus, rotating cutting surfaces of the blade are contacting the medical waste in a perpendicular fashion. This feature reduces the likelihood of the device jamming or malfunctioning.

The blade of the present invention and its cutting surfaces will now be described. The blade, which is rotated by the motor, comprises at least one opening. Each opening is generally rectangular or ovular in shape, i.e., the opening has sides that are longer than other sides of the opening. The longer sides of the opening are generally perpendicular to the axis of rotation of the blade. Importantly, the opening also includes the sharpened edge. The blade must have at least one opening wherein the opening has a sharpened edge. The edge may be sharpened at an angle of approximately  $10^\circ$  to approximately  $90^\circ$ . This angle is shown as angle  $\alpha$  in Figure 7. In a most preferred embodiment, the edge may be sharpened to approximately  $45^\circ$ . The blade also includes at least one raised portion adjacent to the sharpened edge. The raised portion protrudes from the generally flat surface of the blade. The raised portion contacts the medical waste being chopped by the blade and the cutting plate and pushes it away from the cutting plate such that the chopping mechanism of the blade and the cutting plate does not jam with waste and render the device inoperable. The raised portion should be of sufficient height compared to the blade to push the chopped medical waste away from the cutting plate.

Although any number of openings may be used in the blade, preferred embodiments include approximately 2 to approximately 8 openings. In a most preferred embodiment, the blade has 4 openings. The blade may be any shape that is capable of being rotated. However, it is preferred that the blade is circular in shape. Some embodiments of the present invention include a plastic blade with metallic sharpened edges inserted therein. The blade is rotated at speeds to sufficiently chop medical waste. The blade may rotate at approximately 1000 rpm to approximately 10,000 rpm. In a preferred embodiment, the blade rotates at approximately 5,000 to approximately 6,000 rpm.

The blade is preferably made from a high carbon steel, such as, for example, a 4140 steel alloy. It is important that the blade be made of a material harder than any of the stainless steel or other metals commonly used in medical supplies such as razor blades or needles. Preferably, the high carbon steel has a rating of A-6 or higher. Preferably, the blade is made from a single piece  
5 of metal stock and/or is heat-treated.

As the blade is chopping the medical waste, the blade is creating a cyclonic action that creates a down draft to push the chopped particles to the bottom of the lower housing. This down draft and cyclonic action also create an up draft on peripheral edges of the lower housing and up over the blade and back again to the bottom of the lower housing. This feature is illustrated in  
10 Figure 20. This cyclonic action is important since it also helps to reduce the jamming of the blade by keeping the blade and the cutting plate relatively free of debris and causes the medical waste to gather in the bottom of the lower housing.

Although the blade shown operates in a clockwise rotation, one of ordinary skill in the art will realize that the cutting edges of the blade and the cutting plate may be reversed, and likewise,  
15 the rotation of the blade may be reversed.

A critical feature of the present invention is the interaction of the sharpened edge of the blade, the raised portion of the blade, and the cutting plate with its sharpened edge. These three features provide for efficient chopping of the medical waste with minimal jamming of the device. The medical waste is chopped or scissored between the two sharpened edges while the raised  
20 portion pushes the chopped medical waste away from the sharpened edges and through the opening in the blade during the cutting procedure.

Another important feature of the present invention is the ability to operate on direct current. It is surprising that a device capable of chopping medical waste may be operated on direct current since, generally, such a device would need a motor too large to be operated on  
25 direct current. Most prior medical waste disposal devices are operated on alternating current. By the present invention's capability of operating on direct current, the device may be made portable and carried in ambulances or in mobile medical facilities. Direct current operation may provide for operation from a rechargeable battery source. Certain preferred embodiments operate on 12-volt direct current.

30 A preferred motor is commercially available from the Hansen Corporation. Specific Hansen Corporation models include the Series 21 DC motor and the Series 16 DC motor. These motors operate on 12-volt direct current. These motors are relatively small, i.e. approximately 1 and ½ inches by approximately 3 inches in size. Despite their small size, these motors generate

sufficient torque, i.e., about approximately 24 ounces/inch to approximately 40 ounces/inch, which is suitable for reducing material waste.

The present invention provides for the reduction in the volume of medical waste in a ratio of about 500-to-1. This important feature reduces the amount of labor involved in the hospital setting in emptying the lower housing of its waste contents.

The upper and lower housing may be made of a hard material such as a plastic or stainless steel. A gasket may be used in the connection of the upper housing and the lower housing to provide insulation and containment of the medical waste.

The drop shaft may be a diameter of approximately one-half inch. This diameter accommodates most conventional medical waste. However, this size may vary depending on the size of the medical waste to be disposed.

A 6 watt UV germicidal bulb may prove effective for eliminating bacteria and pathogens with chopped waste. Other disinfecting bulbs and germinal products may be used.

The present invention will now be described with reference to the figures:

Figures 1-3 are schematic representations of a medical waste disposal device **100**. The medical waste disposal device **100** includes an upper housing **110** and a lower housing **120**. An on/off switch **130** is shown on the upper housing **110**. Protruding from the upper housing **110** is a drop shaft **135**. The drop shaft **135** receives a plunger **150** through a drop shaft collar **137**. A handle **140** is shown for the plunger **150**. The drop shaft **135** defines a drop shaft opening **136** through which medical waste is inserted.

Figure 4 is a schematic representation of an interior of the medical waste disposal device **100**. A lid **115** is shown removed from the upper housing **110**. The drop shaft **135** passes through a lid opening **117**. A battery **410** and a motor **430** are shown in electrical connection in the interior of the upper housing **110**. The upper housing **110** is penetrated by the drop shaft **135**, which contains the plunger **150**.

The motor **430** includes a drive shaft **435** that protrudes into the lower housing **120** (shown in Figure 11). The blade **200** is mounted or connected to the drive shaft **435**.

Turning now to Figures 5-7, a preferred embodiment for a blade **200** is shown. The blade **200** includes four openings **210**. The openings **210** include a sharpened edge **250** and a raised portion **270**.

Figure 8 shows a six opening blade **600** with openings **610** and raised portions **670**.

Figure 9 shows a two opening blade **700** with openings **710** and raised portions **770**.

Turning now to Figures 10-20, the drop shaft **135** passes through the upper housing **110** until reaching a bottom surface **450** of the upper housing **110**. There, an opening **460** in the

bottom surface 450 provides passage for medical waste 800 to the blade 200, which is rotated by the drive shaft 435. The opening 460 is wholly defined by a cutting plate 500, i.e., the cutting plate fully circumscribes the opening 460. In other embodiments, the cutting plate 500 partially defines the opening 460, i.e. the cutting plate 500 only surrounds a portion of the opening 460.

5 As shown in Figures 17-19, the cutting plate 500 includes a sharpened edge 515, which chops or scissors the medical waste in conjunction with the sharpened edge 250 of the blade. As shown in Figure 17, the cutting plate 500 acts in conjunction and cooperation with the rotating blade 200 in chopping the medical waste 800, i.e., the sharpened edge 515 of the cutting plate 500 operates in conjunction and cooperation with the sharpened edge 250 of the blade 200 to chop or scissor the

10 medical waste 800. As shown in Figure 19, the raised portion 270 contacts the medical waste 800 being chopped by the blade 200 and the cutting plate 500 and pushes it away from the cutting plate 500 and through the opening 210 such that the chopping mechanism of the blade 200 and the cutting plate 500 do not jam with medical waste 800 and render the device inoperable. The action of the rotating blade 200 generally forces the chopped medical waste 801 through the opening 210

15 in the blade 200 into the lower housing 120. The action of the rotating blade 200 that generally forces the chopped medical waste through the opening 210 includes the force from the raised portion 270 striking the medical waste 800 with its sharpened edge 250 as well as the air current created by the rotation of the sharpened edge 250. Although the chopped medical waste 800 generally passes through the opening 210, it will be understood that small fragments or other

20 minor amounts of debris from the medical waste may not immediately pass through the opening 210.

A gasket 530 is shown in Figure 13 which aids in sealing the junction of the upper housing 110 and the lower housing 120.

The bottom surface 450 also includes a UV light 550 and a plate 560 to prevent flying

25 debris from the cutting process from striking and damaging the UV light 550.

A bottom 570 of the lower housing 120 collects the chopped medical waste. Preferably, the lower housing 120 is separable from the upper housing 110 by clips, latches, bolts and the like, such that the operator may remove and empty the reduced medical waste from the lower housing 120.

30 Figures 21 and 22 describe a compact medical waste disposal device of the present invention. This particular embodiment of the device does not use a UV light. Otherwise, the compact medical waste disposal device is similar in operation and function to the other embodiments. This particular embodiment comprises an upper housing 960 and a lower housing 970. A blade 965 is shown to chop or scissor the medical waste. A drop shaft 925 is shown with

an opening 936. The drop shaft 925 receives a plunger 950 with a handle 940. A drop shaft 925 receives the plunger 950 through a drop shaft collar 937.

Other embodiments of the present invention include a blade with multiple openings, with a portion of the openings not having a raised portion and/or a sharpened edge. These openings  
5 and/or the raised portion of the sharpened edge may be necessary for balancing the blade or for aerodynamic reasons.

The medical waste disposal device of the present invention is capable of chopping or scissoring all parts of a typical medical syringe, including the needle and the hub. Generally, no modifications are required to accommodate all types of medical waste. The medical waste  
10 disposal device of the present invention reduces syringes, catheters, lumens, tracheotomy tubes, blades, surgical needles, and associated plastic into a reduced volume that is capable of being recycled. The medical waste, after processing by the present invention, may be taken to a centrifugal separator for separating the metal from the plastic.

Prior art methods and devices of disposing medical waste include the bending of the  
15 syringe tip and the melting of the syringe tip. The present invention grinds the entire syringe including tip, hub, and reservoir. This provides an important advantage over the prior art as the operator is not required to physically touch the needle or bend the needle or remove the needle from the remainder of the syringe, thus reducing the likelihood of an unintentional needle prick that could contaminate the user with germs and/or bacteria.

20 Other prior art devices are prone to jamming for a variety of reasons, such as poor design of its grinding mechanisms. Other prior art devices are simply too large and require too much electrical current to be feasible for hospital room use.

As evident from the foregoing description, certain aspects of the present invention are not limited by the particular details of the examples illustrated herein, and it is therefore contemplated  
25 that other modifications and applications, or equivalents thereof, will occur to those skilled in the art. It is accordingly intended that all claims shall cover all such modifications and applications that do not depart from the spirit and the scope of the present invention.

## What is claimed:

1. A medical waste disposal device, comprising:  
a blade comprising:  
5                   one or more openings, wherein at least one opening has a  
                    first sharpened edge; and  
                    at least one raised portion that is adjacent to the at least one opening;  
a motor for rotating the blade; and  
a cutting plate with a second sharpened edge.
- 10    2. The medical waste disposal device according to Claim 1, wherein medical waste is  
chopped or scissored between the first sharpened edge and the second sharpened edge while the  
raised portion pushes the chopped medical waste away from the first and the second sharpened  
edges in the chopping or scissoring of the medical waste.
3. The medical waste disposal device according to Claim 1, wherein the blade  
comprises two to eight openings.
- 15    4. The medical waste disposal device according to Claim 1, further comprising a  
housing that comprises the motor and the blade.
5. The medical waste disposal device according to Claim 4, further comprising a drop  
shaft that passes through the housing until reaching a bottom surface of the housing, and an  
opening in the bottom surface provides passage for medical waste to the blade.
- 20    6. The medical waste disposal device according to Claim 5, wherein the opening in  
the bottom surface is wholly or partially defined by the cutting plate.
7. The medical waste disposal device according to Claim 1, further comprising:  
a housing that comprises a lower housing and an upper housing, wherein the upper  
housing comprises the motor and the lower housing comprises the blade and contains the  
25    chopped or scissored medical waste; and  
a drop shaft which passes through the upper housing until reaching a bottom  
surface of the upper housing, and an opening in the bottom surface which provides  
passage for the medical waste to the blade, wherein the opening is wholly or partially  
defined by the cutting plate.
- 30    8. The medical waste disposal device according to Claim 7, wherein a drive shaft  
from the motor protrudes into the lower housing and the blade is connected or attached to the  
drive shaft.

9. The medical waste disposal device according to Claim 1, wherein the medical waste disposal device reduces syringes, catheters, lumens, tracheotomy tubes, blades or surgical needles.

10. The medical waste disposal device according to Claim 1, wherein the medical waste disposal device operates on direct current.

11. The medical waste disposal device according to Claim 1, wherein the medical waste disposal device reduces the volume of medical waste in a ratio of about 500-to-1.

12. The medical waste disposal device according to Claim 1, wherein the medical waste disposal device rotates the blade at approximately 1,000 rpm to approximately 10,000 rpm.

13. The medical waste disposal device according to Claim 1, wherein the medical waste disposal device comprises a UV light in a lower housing.

14. The medical waste disposal device according to Claim 1, wherein the medical waste disposal device comprises a UV light on a lower portion of an upper housing to disinfect or sterilize the chopped and scissored medical waste.

15. The medical waste disposal device according to Claim 1, further comprising a housing, wherein the medical waste disposal device creates a cyclonic action that creates a down draft to push the chopped particles to the bottom of the housing, and the down draft and the cyclonic action create an up draft on peripheral edges of the housing and up over the blade and back again to the bottom of the housing.

16. The medical waste disposal device according to Claim 15, wherein the cyclonic action cleans the blade and reduces the occurrence of medical waste jamming in the blade.

17. The medical waste disposal device according to Claim 1, further comprising:

a housing that comprises a lower housing and an upper housing, wherein the upper housing comprises the motor and the lower housing comprises the blade;

25 a drop shaft that passes through the upper housing until reaching a bottom surface of the upper housing, and an opening in the bottom surface provides passage for the medical waste to the blade, wherein the opening is wholly or partially defined by the cutting plate, and wherein the lower housing contains the chopped or scissored medical waste; and

30 the drop shaft directs medical waste in a vertical manner to the blade.

18. The medical waste disposal device according to Claim 1, wherein the medical waste disposal device operates on 12-volt direct current.

19. The medical waste disposal device according to Claim 18, wherein the medical waste device is portable.

20. The medical waste disposal device according to Claim 1, wherein the first sharpened edge of the blade is sharpened at an angle of approximately 10° to approximately 90°.

21. The medical waste disposal device according to Claim 1, wherein the raised portion contacts the medical waste being chopped by the blade and pushes it away from the cutting plate such that the chopping mechanism of the blade and the cutting plate do not jam with medical waste.

22. The medical waste disposal device according to Claim 1, wherein the at least one opening is generally rectangular or ovular in shape.

23. The medical waste disposal device according to Claim 1, wherein the medical waste is chopped or scissored between the first and second sharpened edges while the raised portion pushes the medical waste away from the sharpened edges and through the at least one opening in the blade.

24. A blade for chopping or scissoring medical waste, comprising:

one or more openings, wherein at least one opening has a

first sharpened edge; and

a raised portion that is adjacent to the at least one opening;

wherein the blade is used in conjunction with a cutting plate with a second sharpened edge.

25. A method of reducing medical waste, comprising:

directing medical waste to a rotating blade,

wherein the blade comprises:

one or more openings, wherein at least one opening has a

first sharpened edge; and

a raised portion that is adjacent to the at least one opening;

a motor for rotating the blade; and

a cutting plate with a second sharpened edge; and

reducing the medical waste into a lesser volume.

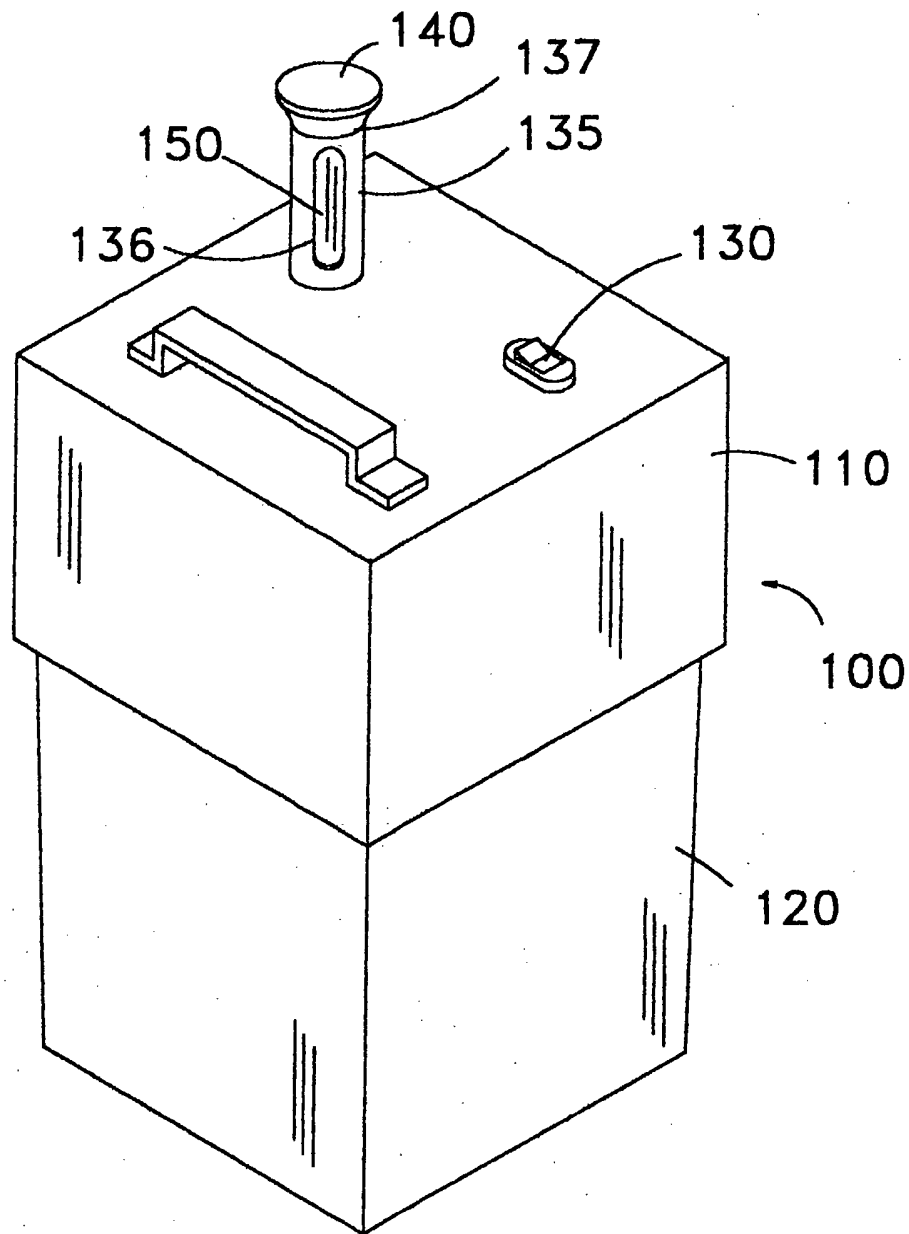

FIG. 1

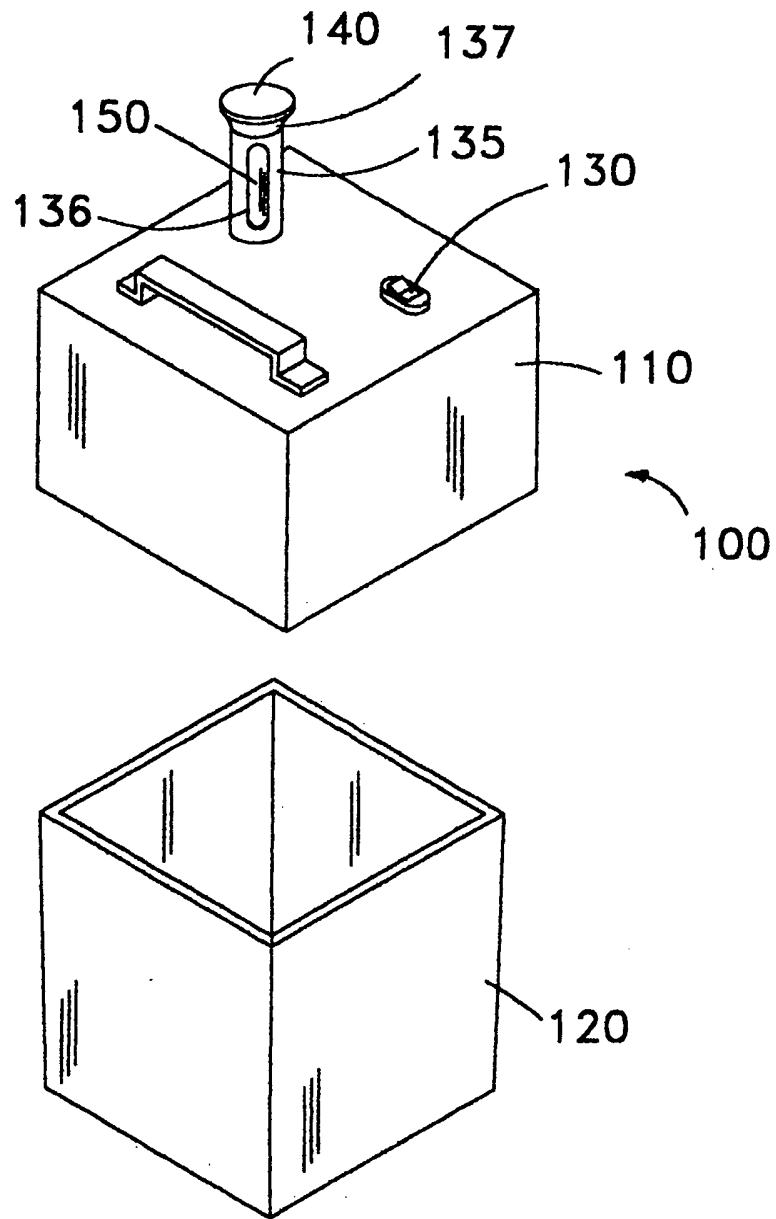

FIG. 2

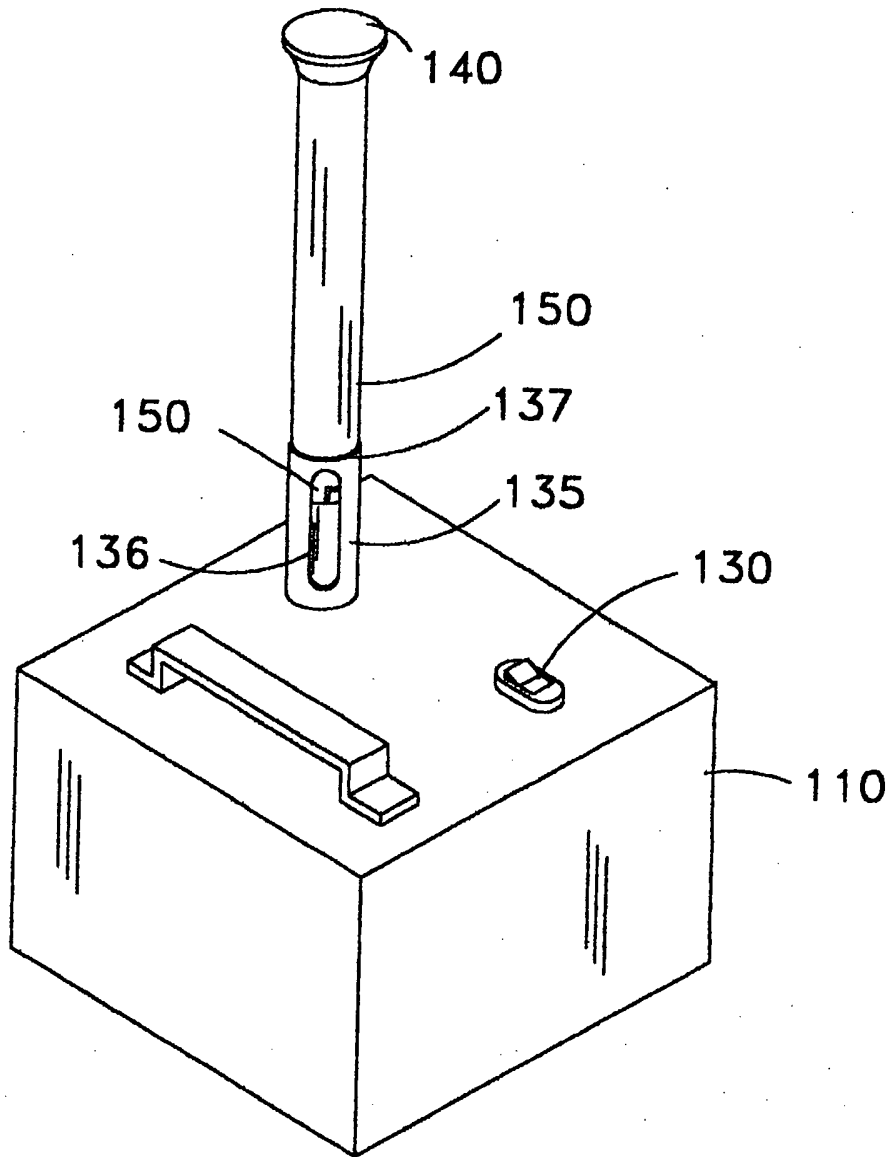

FIG. 3

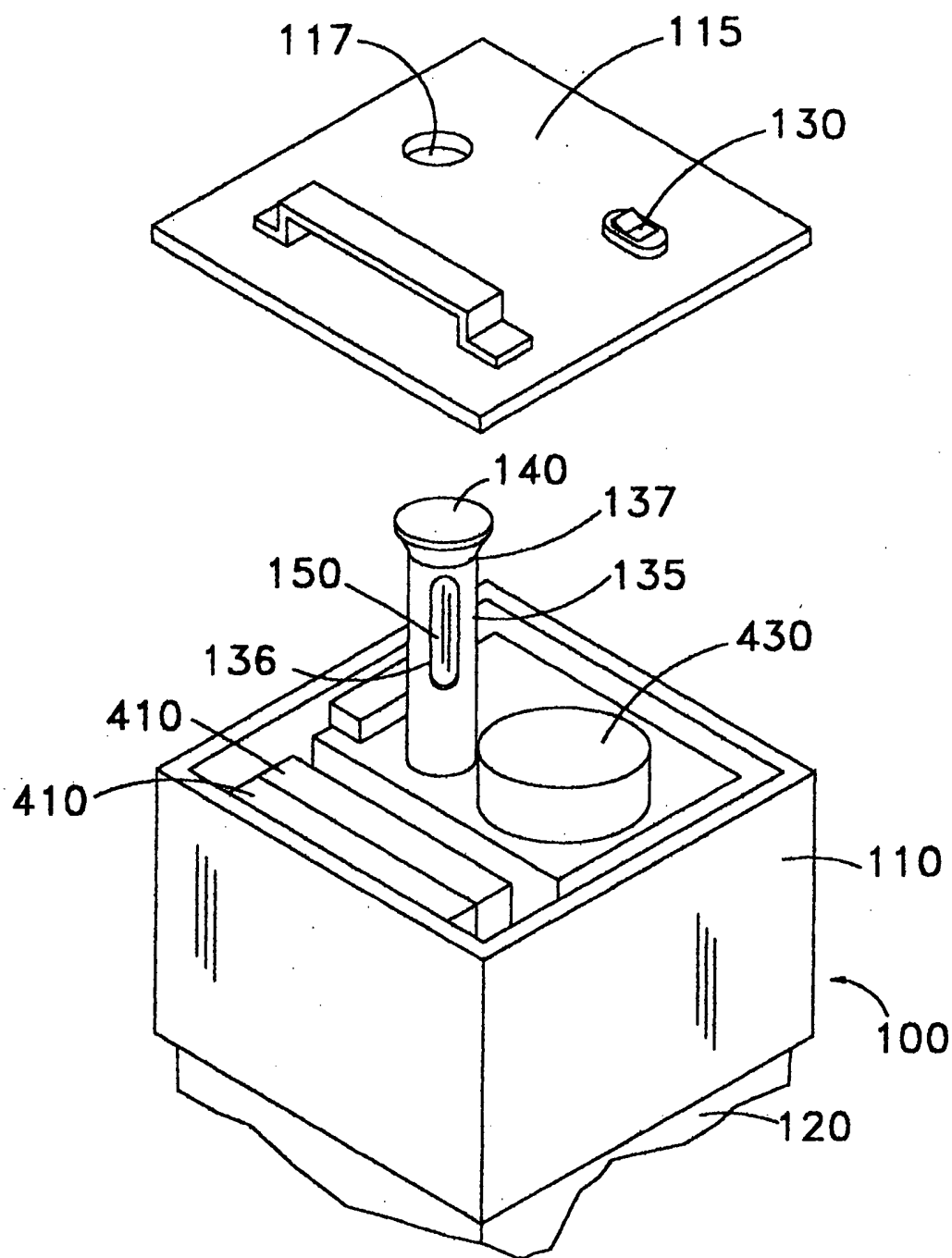

FIG. 4

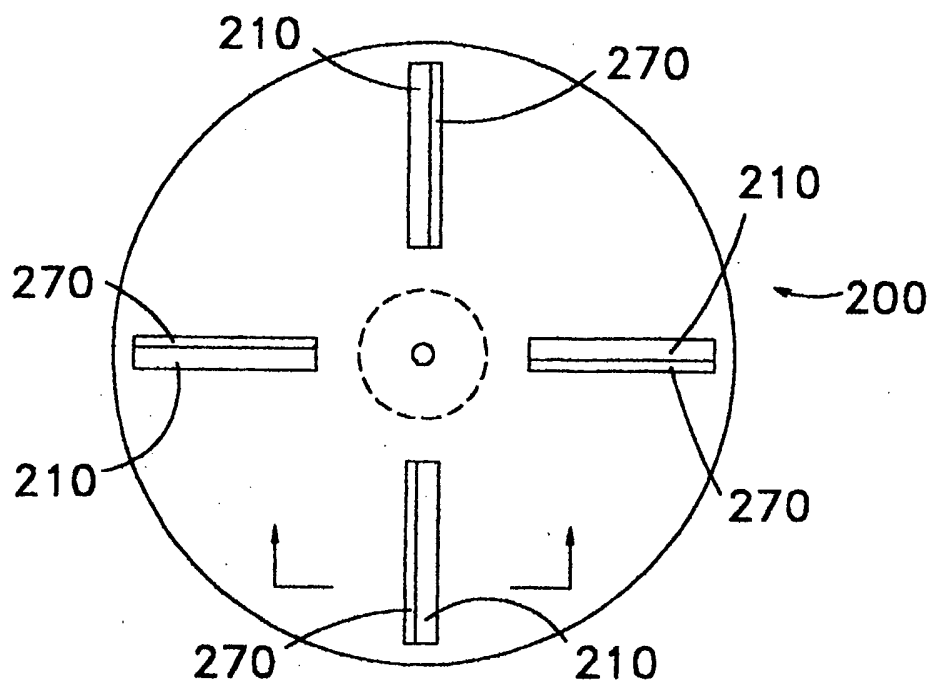

FIG. 5

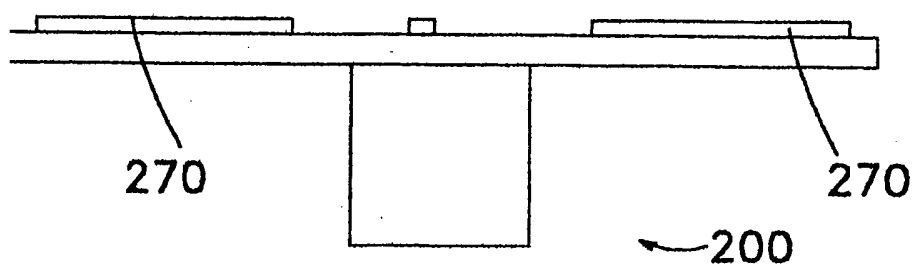

FIG. 6

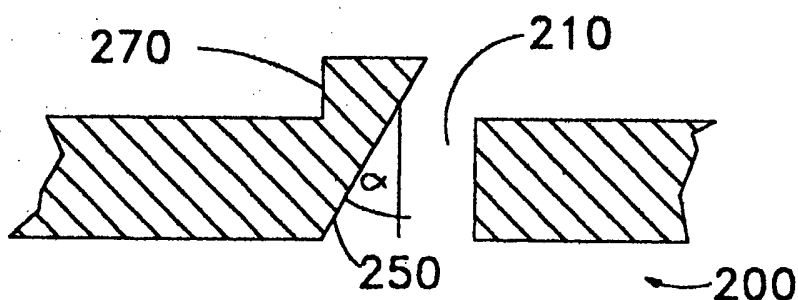

FIG. 7

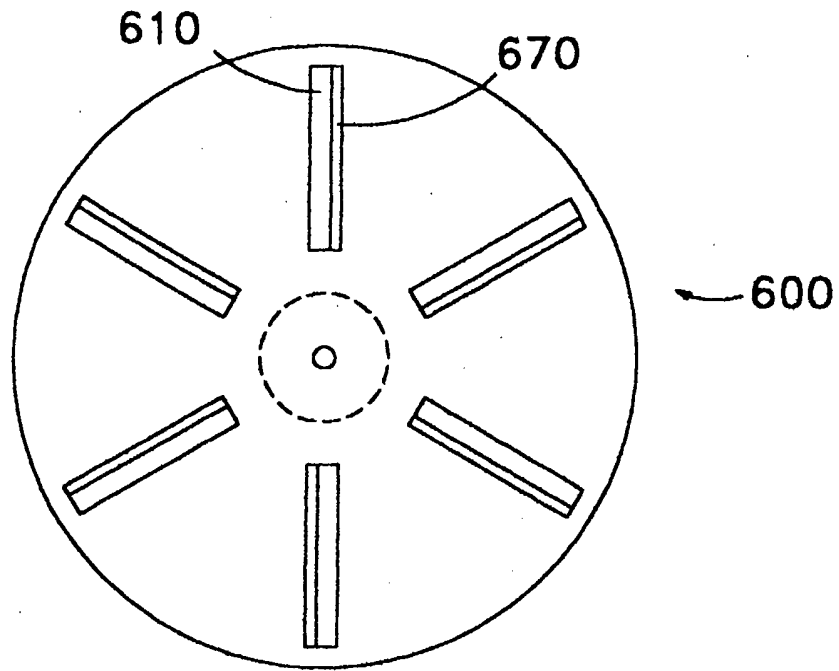

FIG. 8

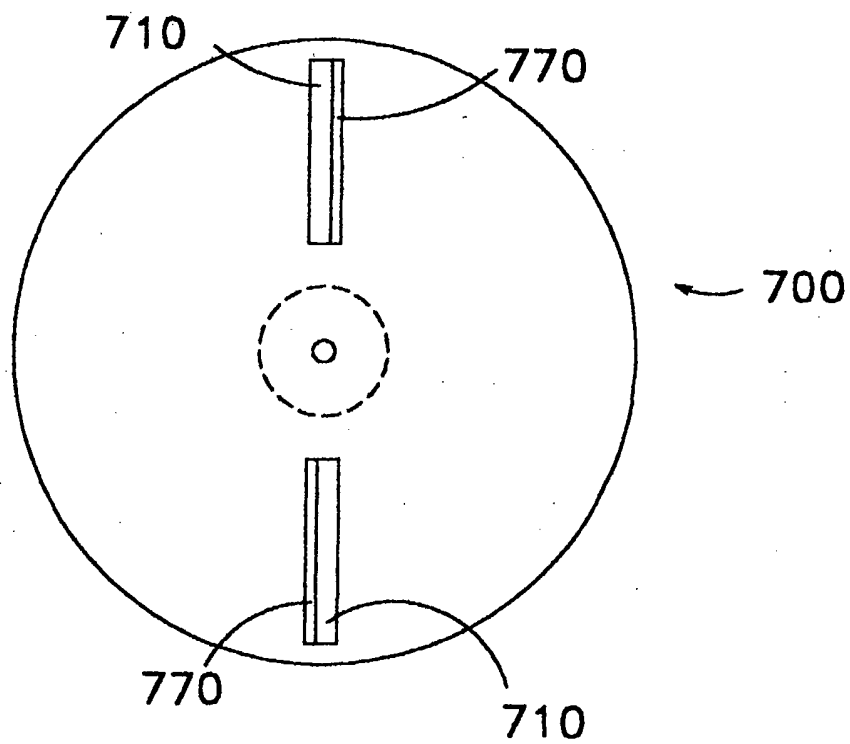

FIG. 9

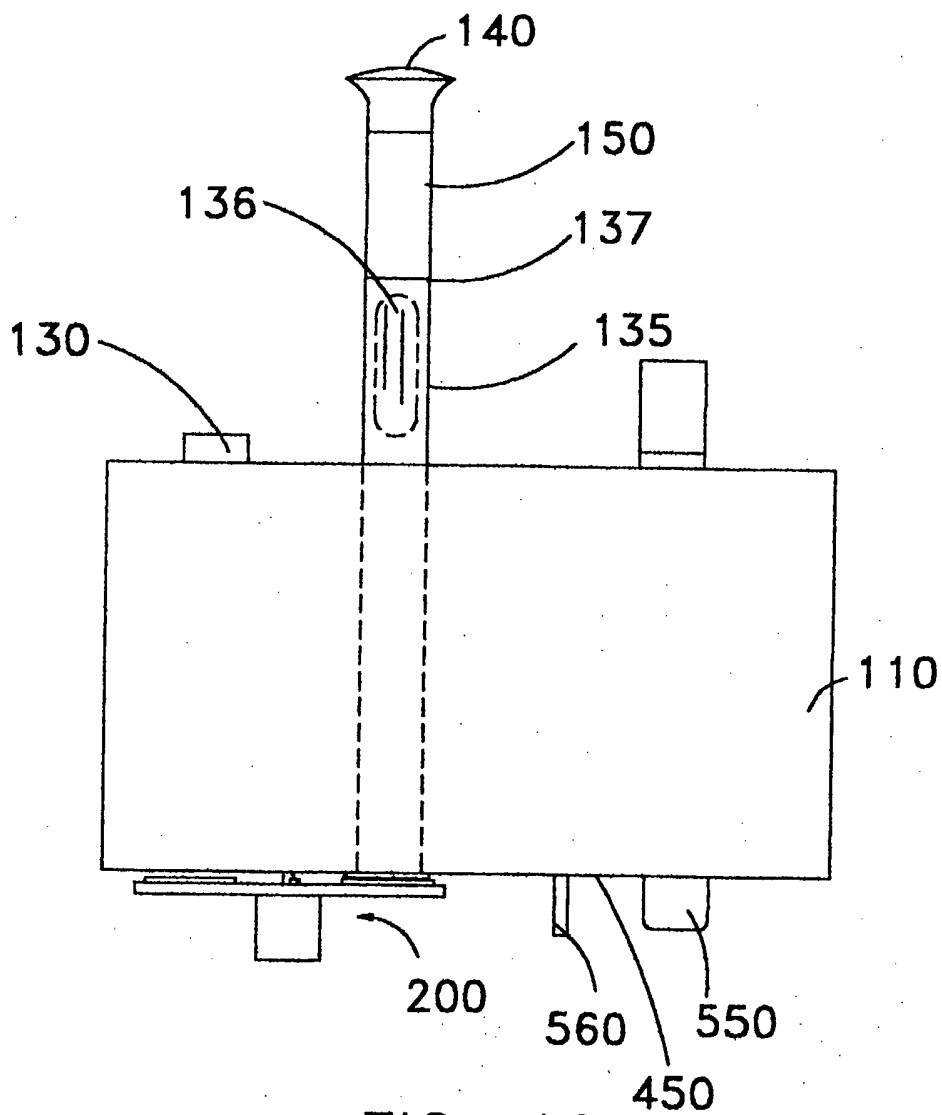

FIG. 10

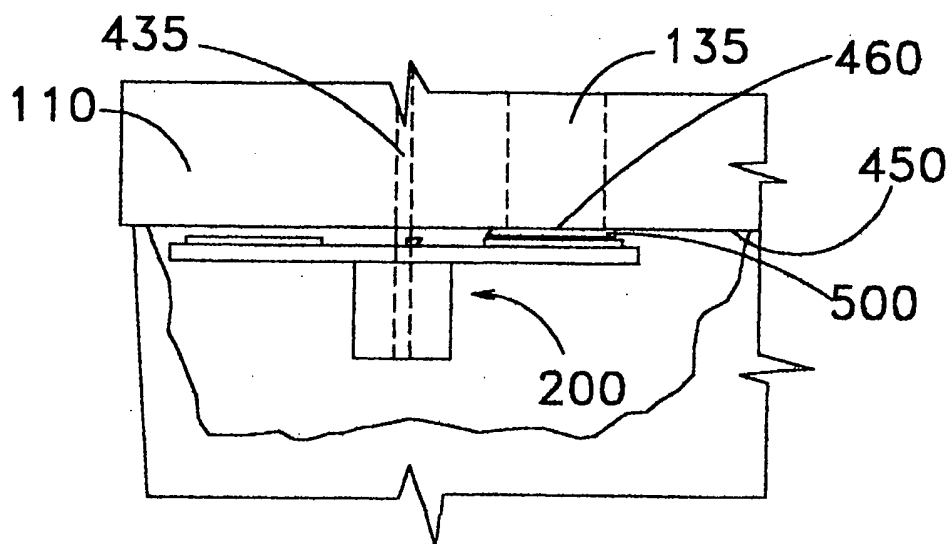

FIG. 11

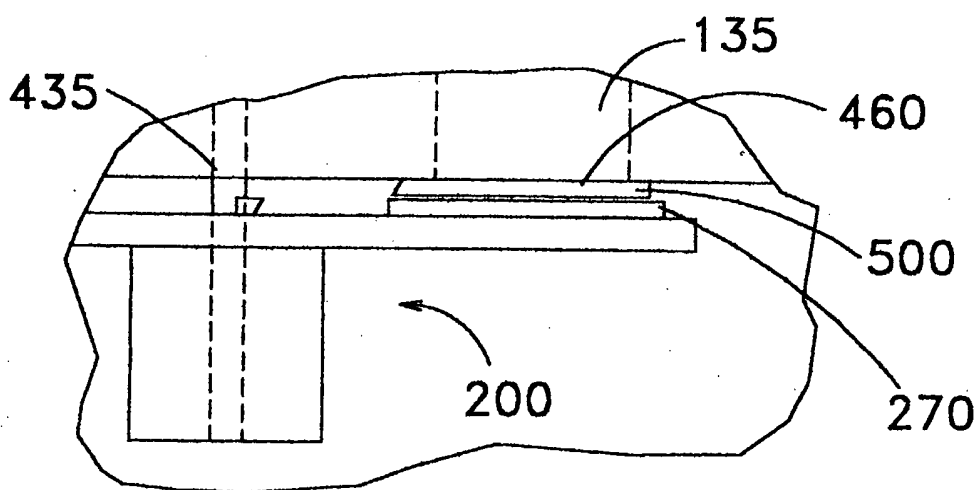

FIG. 12

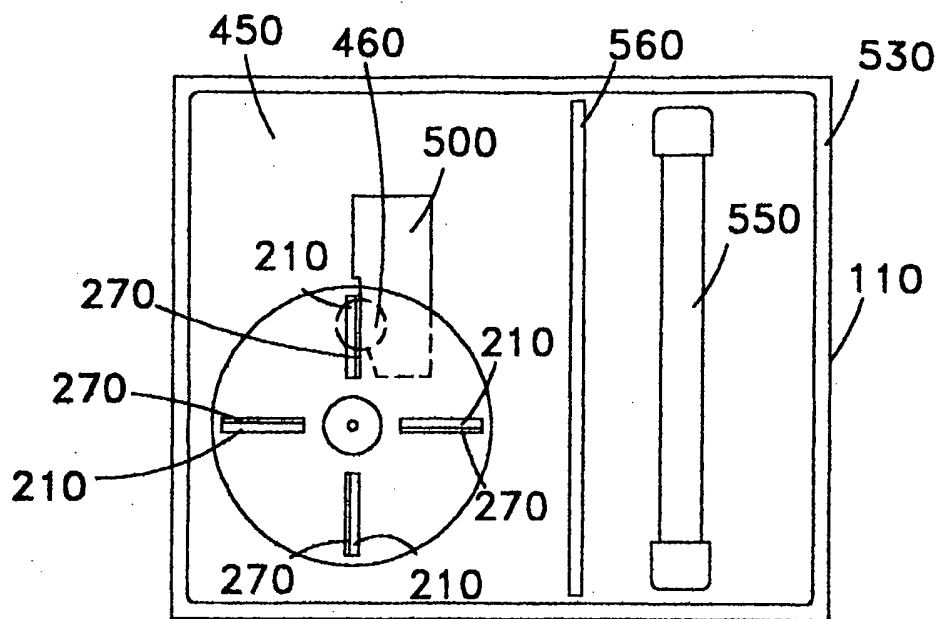

FIG. 13

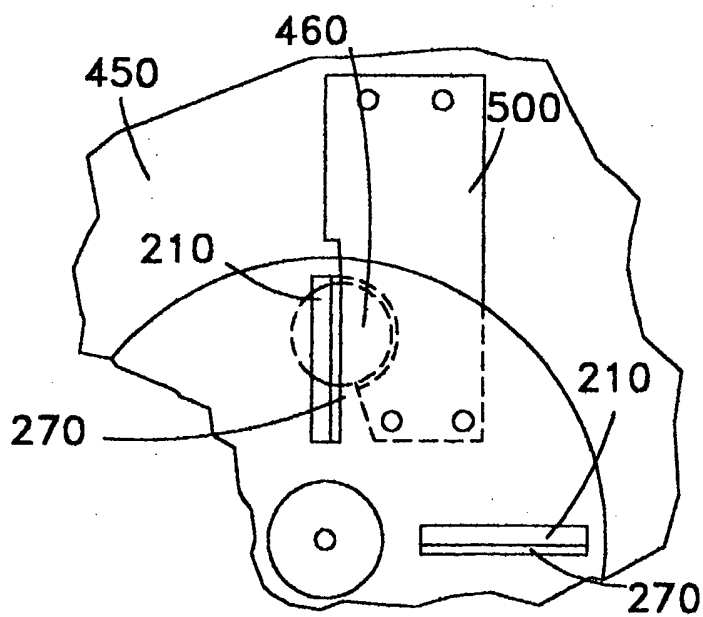

FIG. 14

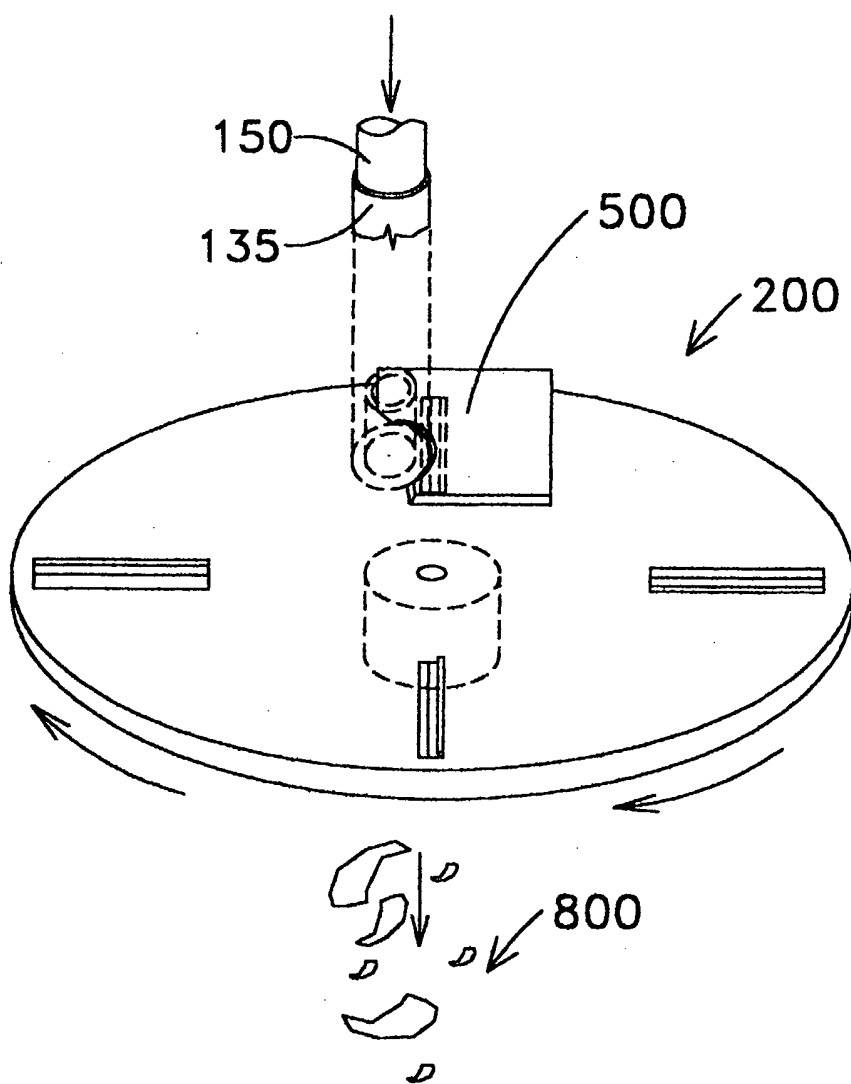

FIG. 15

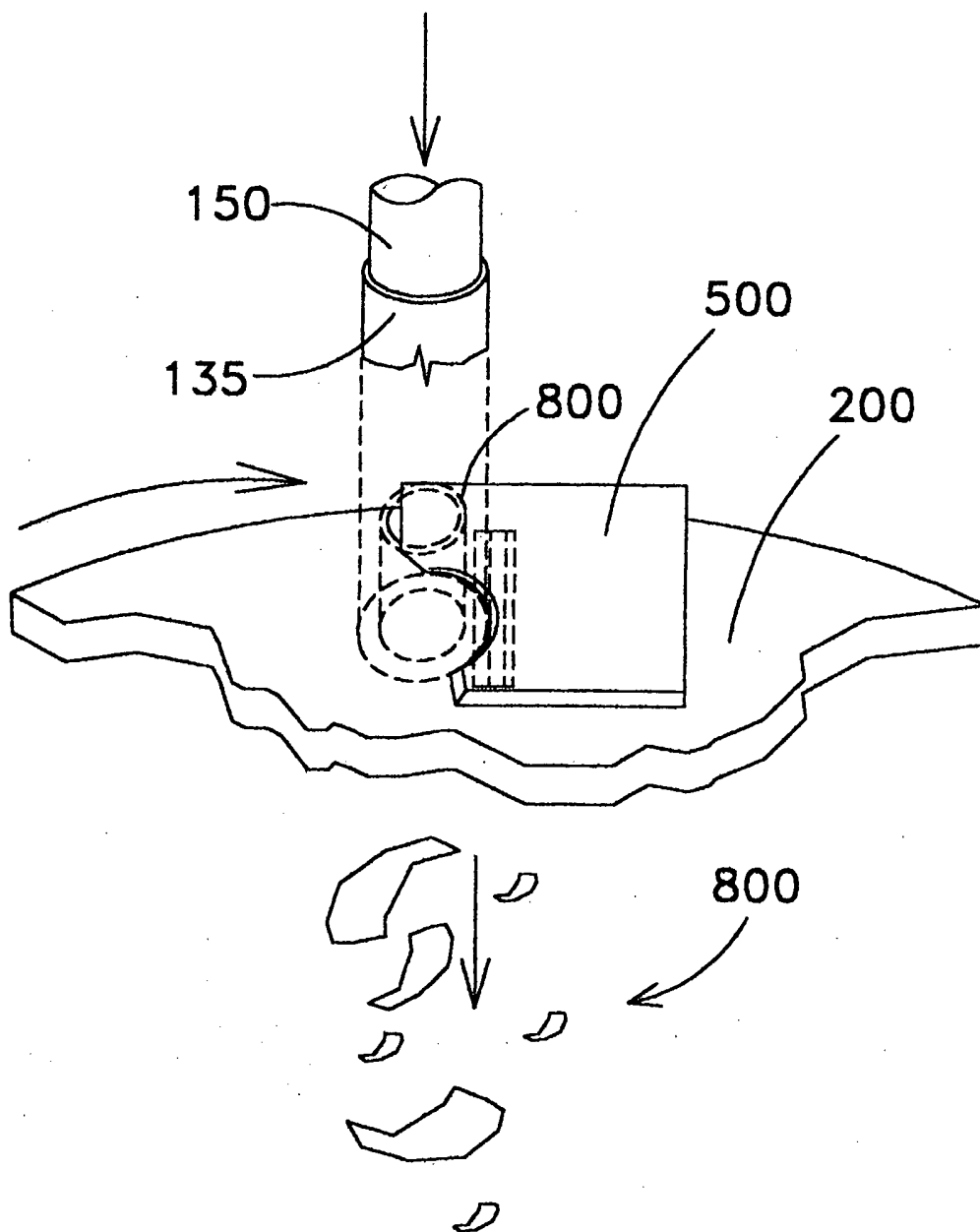

FIG. 16

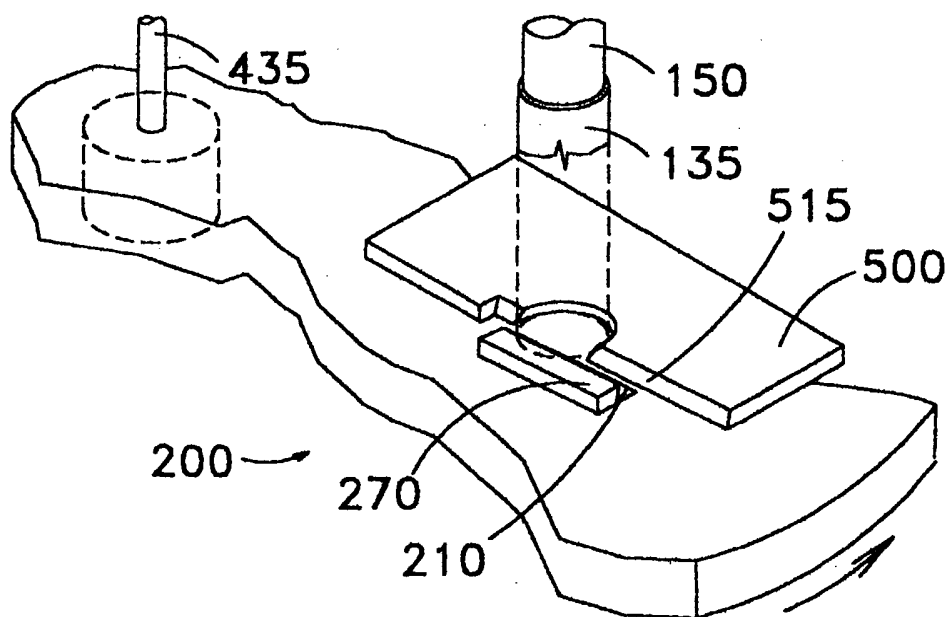

FIG. 17

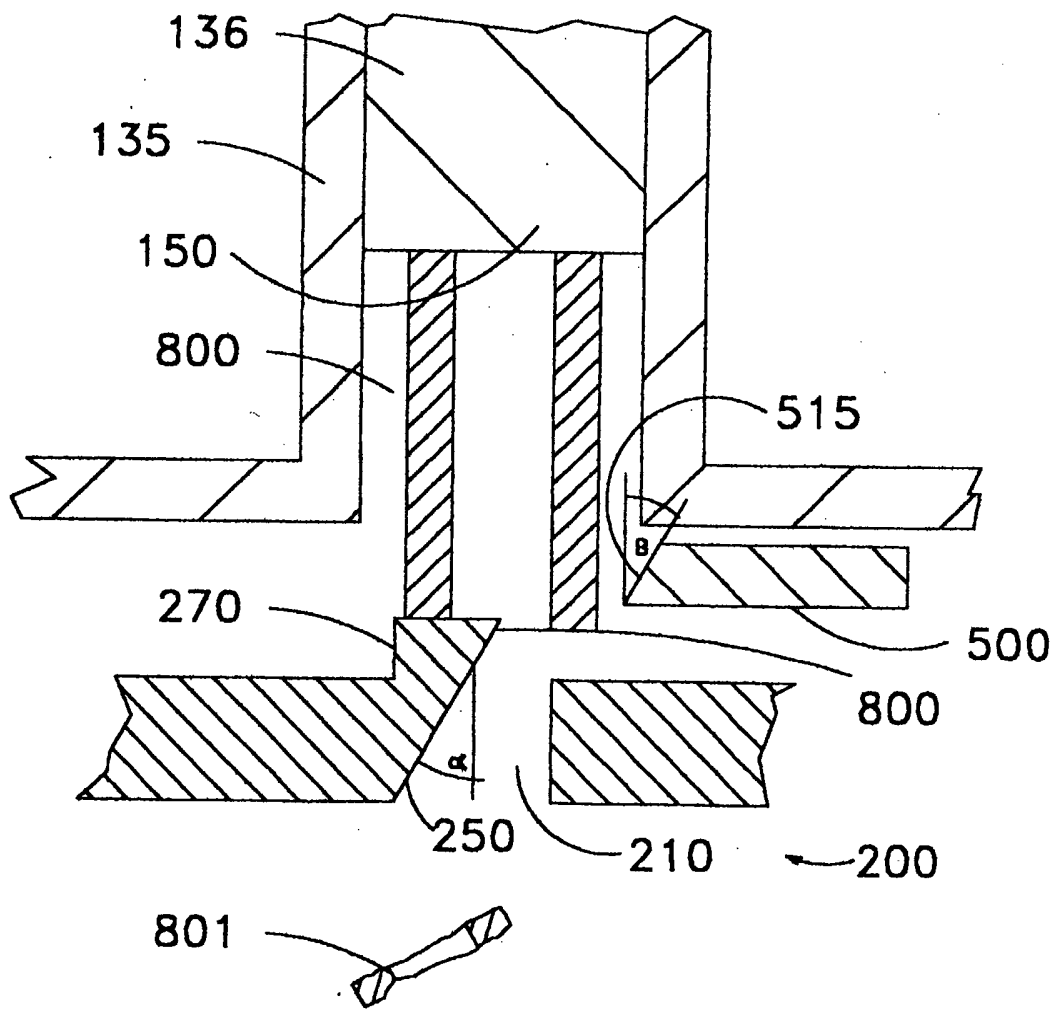

FIG. 19

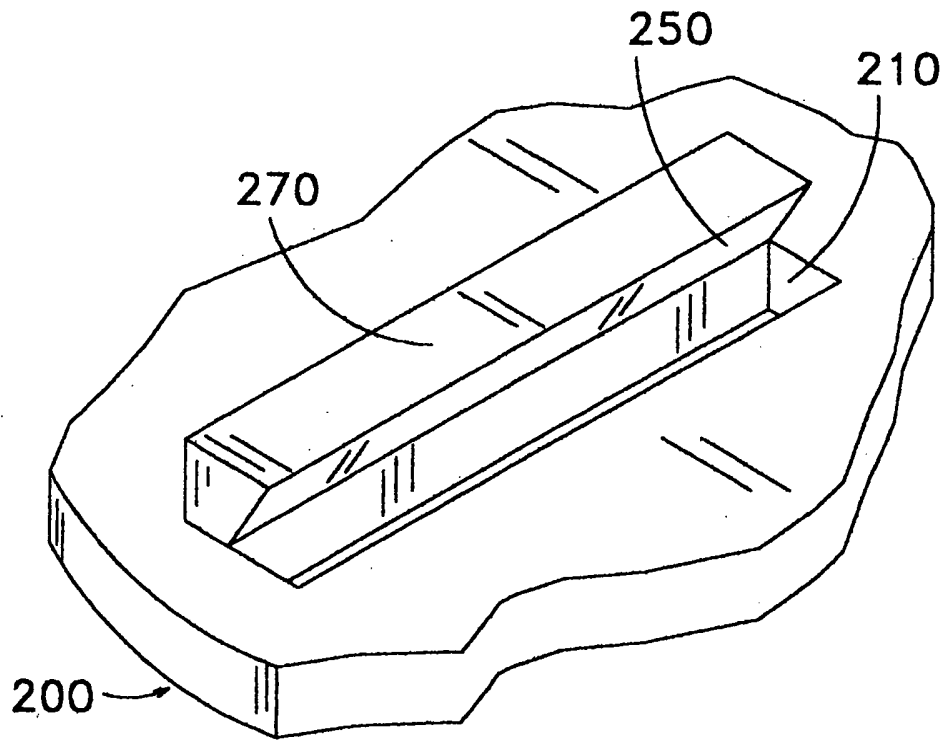

FIG. 18

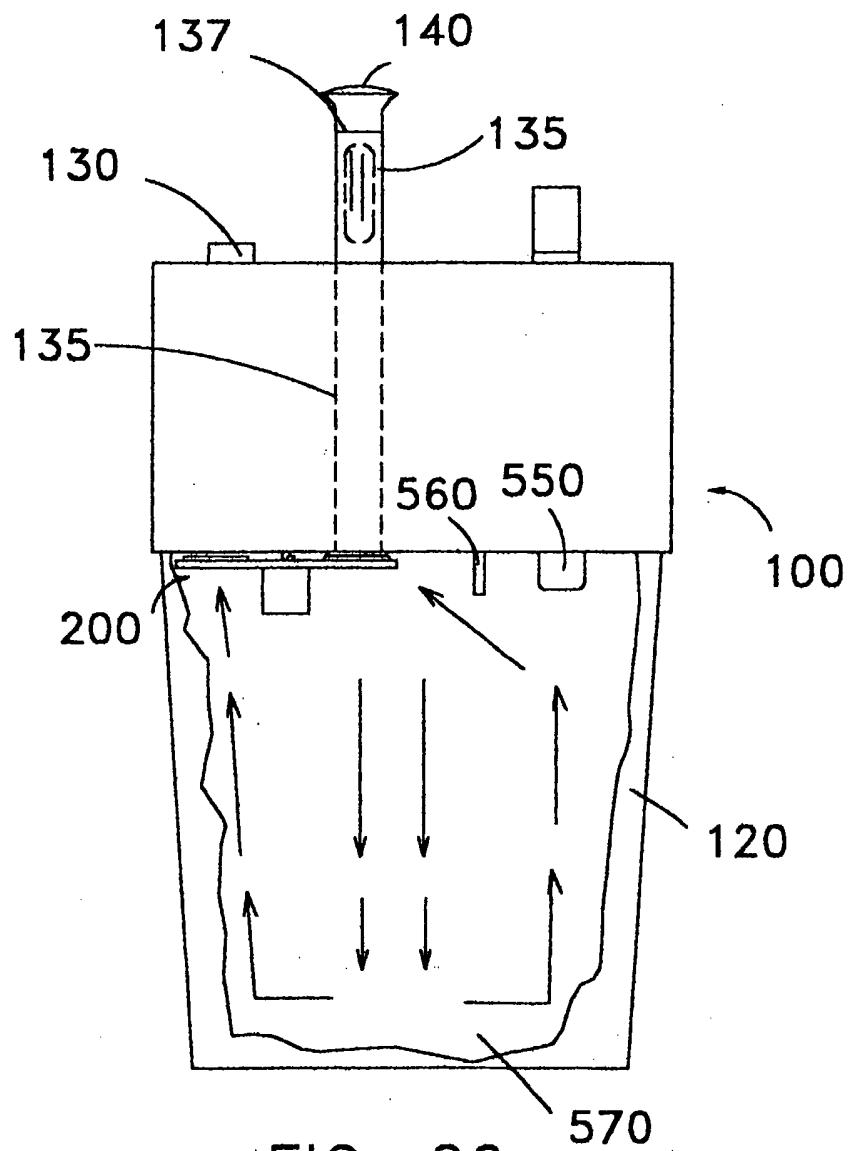

FIG. 20

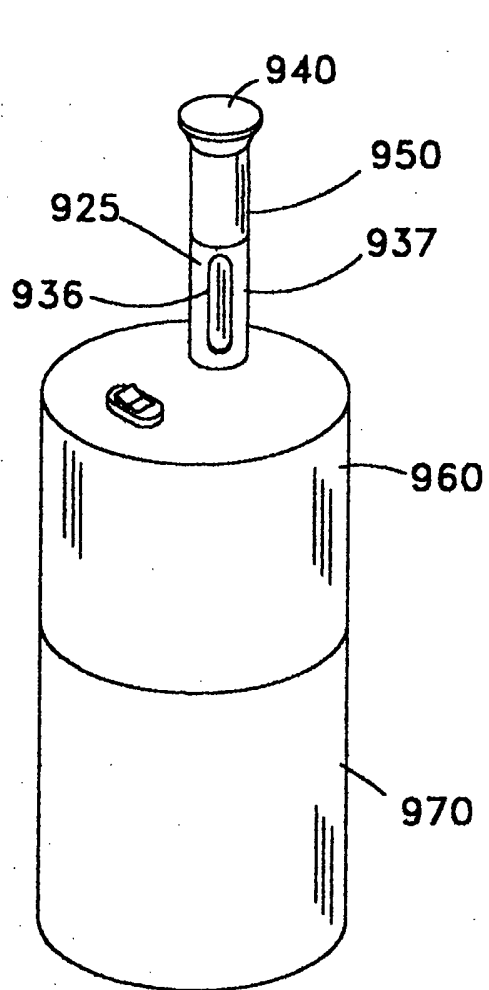

FIG. 21

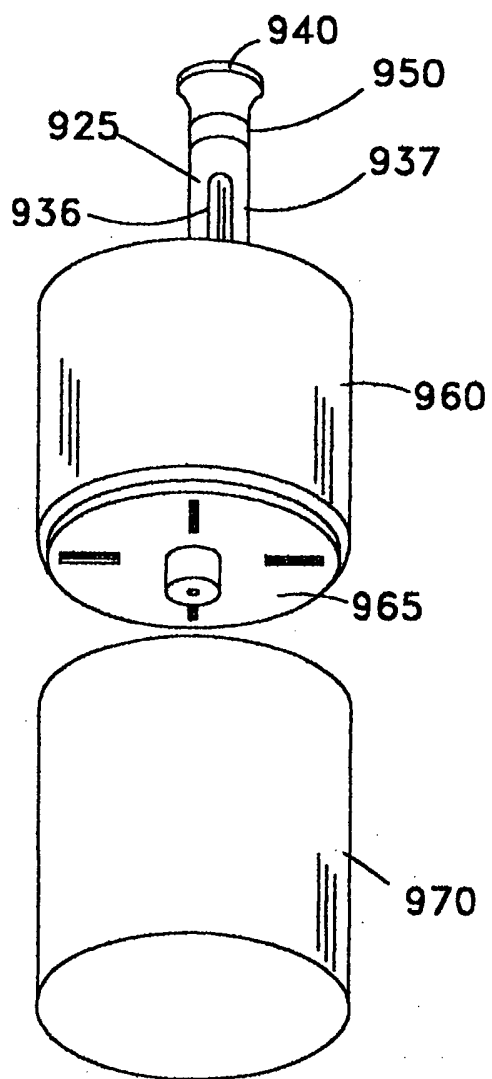

FIG. 22