



(51) International Patent Classification:

E05B 39/02 (2006.01) E05B 63/00 (2006.01)
E05B 65/10 (2006.01)

(21) International Application Number:

PCT/US2014/018776

(22) International Filing Date:

26 February 2014 (26.02.2014)

(25) Filing Language:

English

(26) Publication Language:

English

(30) Priority Data:

13/777,853 26 February 2013 (26.02.2013) US

(71) Applicant: APICAL INDUSTRIES, INC. [US/US]; 2608 Temple Heights Drive, Oceanside, CA 92056 (US).

(72) Inventors: CAPONERA, Nicholas, Philip; 82 Dahlgren Road, Valatie, NY 12184 (US). ANDERSSON, Sven, Emil; 2108 Madera Drive, Oceanside, CA 92056 (US).

(74) Agent: HAHN, Peter, K.; Pillsbury Winthrop Shaw Pittman LLP, 501 West Broadway, Suite 1100, San Diego, CA 92101-3575 (US).

(81) Designated States (unless otherwise indicated, for every kind of national protection available): AE, AG, AL, AM,

AO, AT, AU, AZ, BA, BB, BG, BH, BN, BR, BW, BY, BZ, CA, CH, CL, CN, CO, CR, CU, CZ, DE, DK, DM, DO, DZ, EC, EE, EG, ES, FI, GB, GD, GE, GH, GM, GT, HN, HR, HU, ID, IL, IN, IR, IS, JP, KE, KG, KN, KP, KR, KZ, LA, LC, LK, LR, LS, LT, LU, LY, MA, MD, ME, MG, MK, MN, MW, MX, MY, MZ, NA, NG, NI, NO, NZ, OM, PA, PE, PG, PH, PL, PT, QA, RO, RS, RU, RW, SA, SC, SD, SE, SG, SK, SL, SM, ST, SV, SY, TH, TJ, TM, TN, TR, TT, TZ, UA, UG, US, UZ, VC, VN, ZA, ZM, ZW.

(84) Designated States (unless otherwise indicated, for every kind of regional protection available): ARIPO (BW, GH, GM, KE, LR, LS, MW, MZ, NA, RW, SD, SL, SZ, TZ, UG, ZM, ZW), Eurasian (AM, AZ, BY, KG, KZ, RU, TJ, TM), European (AL, AT, BE, BG, CH, CY, CZ, DE, DK, EE, ES, FI, FR, GB, GR, HR, HU, IE, IS, IT, LT, LU, LV, MC, MK, MT, NL, NO, PL, PT, RO, RS, SE, SI, SK, SM, TR), OAPI (BF, BJ, CF, CG, CL, CM, GA, GN, GQ, GW, KM, ML, MR, NE, SN, TD, TG).

Published:

- with international search report (Art. 21(3))
- before the expiration of the time limit for amending the claims and to be republished in the event of receipt of amendments (Rule 48.2(h))

(54) Title: FRANGIBLE FASTENER

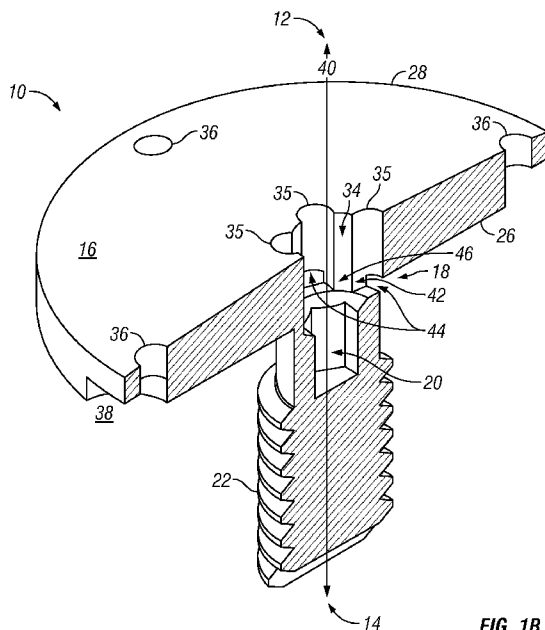

FIG. 1B

(57) Abstract: This disclosure relates to a frangible fastener configured such that a first end of the fastener separates from a second end of the fastener responsive to a breaking force. The fastener may comprise a head portion, a frangible portion, a tool engagement portion, a threaded portion, and/or other portions. The frangible portion may include a frangible body. The frangible body may form a plurality of through wall cuts. The frangible portion may be configured such that the breaking force is proportional to a quantity of through wall cuts, a cross sectional area of through wall cuts, and/or a shape of through wall cuts. The frangible portion may be configured such that the breaking force is proportional to a wall thickness of the frangible body. The location of the tool engagement portion may minimize and/or eliminate torsional loading of the frangible portion during tightening with a tightening tool.



FRANGIBLE FASTENER

CROSS-REFERENCE TO RELATED APPLICATION

(01) This application claims priority to U.S. Patent Application Serial No. 13/777,853 filed February 26, 2013, the entire contents of which are hereby incorporated by reference.

FIELD OF THE DISCLOSURE

(02) This disclosure relates to a frangible fastener configured such that a first end of the fastener separates from a second end of the fastener responsive to a breaking force.

BACKGROUND

(03) Frangible fasteners are known. Frangible fasteners break when subjected to forces above threshold levels. Frangible fasteners are commonly used to couple two or more structural components that are configured to separate when subjected to forces above the threshold levels. For example, an emergency compartment door may be closed and secured by frangible fasteners. These frangible fasteners are designed to break when the pressure exerted against the door reaches a certain level. Once the fasteners break the compartment door can open. Often, frangible fasteners are composed of multiple pieces joined together to make one device. Also, typical frangible fasteners may be limited by an amount of torque that may be applied to the fastener during installation so that the fastener does not break during installation.

SUMMARY

(04) One aspect of the disclosure relates to a frangible fastener. The frangible fastener may be configured such that the first end separates from the second end responsive to a breaking force. In some implementations, the fastener may comprise a head portion, a frangible portion, a tool engagement portion, a threaded portion, and/or other portions.

(05) The head portion may be located at the first end of the fastener. The head portion may include a channel configured to receive a tightening tool. The head portion may include a plurality of peripheral holes configured to receive safety wiring.

(06) The frangible portion may be located adjacent to the head portion toward the second end along a first axis. The frangible portion may comprise a frangible body having a plurality of through wall cuts in a wall thickness of the frangible body. The frangible body may be configured to separate at or near the through wall cuts responsive to the breaking force. In some implementations, the frangible body may have a generally tubular form. The through wall cuts may comprise radial through wall cuts in the wall thickness of the tube on a plane substantially perpendicular to the first axis. In some implementations, the frangible portion may be configured to conduct the tightening tool from the channel in the head portion to the tool engagement portion through a conduit formed by the tubular frangible body.

(07) In some implementations, the frangible portion may be configured such that the breaking force is between about 5 pounds and about 400 pounds. In some implementations, the frangible portion may be configured to separate responsive to one or more of a tensile force, a shear force, and/or other forces. In some implementations, the frangible portion may be configured such that the breaking

force is proportional to the magnitude of the through wall cuts. The magnitude of the through wall cuts may comprise a quantity of the through wall cuts, a cross sectional area of the through wall cuts, a shape of the through wall cuts, and/or other properties of the through wall cuts. In some implementations, the frangible body may form three through wall cuts in the wall thickness of the frangible body. In some implementations, the frangible body may form five through wall cuts in the wall thickness of the frangible body.

(08) In some implementations, the frangible portion may be configured such that the breaking force is proportional to the wall thickness of the frangible body. In some implementations, the frangible portion may be configured such that the breaking force is proportional to inherent material properties of the frangible portion. The inherent material properties may include one or more of tensile strength, shear strength, and/or other material properties of the material used to form the frangible fastener.

(09) The tool engagement portion may be configured to engage the tightening tool. The tool engagement portion may be located adjacent to the frangible portion toward the second end along the first axis.

(10) The threaded portion may be located adjacent to the tool engagement portion at the second end of the fastener along the first axis. In some implementations, the threaded portion may be cylindrically shaped. The threads may be located on the outside of the cylinder. In some implementations, the threaded portion may include a second tool engagement portion at the second end of the fastener. The second tool engagement portion may be configured to receive a removal tool.

(11) Another aspect of the present disclosure relates to a method for fabricating a frangible fastener such that the first end of the fastener separates from the second end of the fastener responsive to a breaking force. The method may comprise forming a head portion at the first end of the fastener; forming a frangible portion adjacent to the head portion toward the second end along a first axis; forming a tool engagement portion such that the tool engagement portion is configured to engage a tightening tool; forming a threaded portion adjacent to the tool engagement portion at the second end of the fastener along the first axis, and/or forming other components of the frangible fastener.

(12) In some implementations, the frangible portion may be formed with a frangible body. The frangible body may be formed with a plurality of through wall cuts in a wall thickness of the frangible body. The frangible body may be formed such that the frangible body separates at or near the through wall cuts responsive to the breaking force. The frangible body may be formed such that the frangible body has a generally tubular form and the through wall cuts are radial through wall cuts in the wall thickness of the tube on a plane substantially perpendicular to the first axis.

(13) In some implementations, the frangible portion may be formed such that the breaking force is proportional to a magnitude of the through wall cuts. The magnitude of the through wall cuts may comprise one or more of a quantity of the through wall cuts, a cross sectional area of the through wall cuts, a shape of the through wall cuts, and/or other properties of the through wall cuts. In some implementations, the frangible portion may be formed such that the breaking force is proportional to the wall thickness of the frangible body.

(14) In some implementations, the tool engagement portion may be formed adjacent to the frangible portion toward the second end along the first axis.

(15) In some implementations, the threaded portion may be formed adjacent to the tool engagement portion at the second end of the fastener along the first axis.

(16) These and other features, and characteristics of the present technology, as well as the methods of operation and functions of the related elements of structure and the combination of parts and economies of manufacture, will become more apparent upon consideration of the following description and the appended claims with reference to the accompanying drawings, all of which form a part of this specification, wherein like reference numerals designate corresponding parts in the various figures. It is to be expressly understood, however, that the drawings are for the purpose of illustration and description only and are not intended as a definition of the limits of the invention. As used in the specification and in the claims, the singular form of "a", "an", and "the" include plural referents unless the context clearly dictates otherwise.

BRIEF DESCRIPTION OF THE DRAWINGS

(17) FIG. 1A-1D illustrate a frangible fastener configured such that a first end of the fastener separates from a second end of the fastener responsive to a breaking force;

(18) FIG. 1A is a perspective view of the fastener;

(19) FIG. 1B is a section view of the fastener;

(20) FIG. 1C is a side view of the fastener;

(21) FIG. 1D is an end view of the first end of the fastener;

- (22) FIG. 2A illustrates an exemplary implementation of a frangible body;
- (23) FIG. 2B illustrates a second implementation of a frangible body; and
- (24) FIG. 3 illustrates a method for fabricating a frangible fastener such that a first end of the fastener separates from a second end of the fastener responsive to a breaking force.

DETAILED DESCRIPTION

(25) In the following paragraphs, implementations of the present disclosure will be described in detail by way of example with reference to the accompanying drawings, which are not necessarily drawn to scale, and the illustrated components are not necessarily drawn proportionately to one another. Throughout this description, the implementations and examples shown should be considered as exemplars, rather than as limitations on the present disclosure. As used herein, the “present disclosure” refers to any one of the embodiments of the disclosure described herein, and any equivalents. Furthermore, reference to various aspects of the disclosure throughout this document does not mean that all claimed embodiments or methods must include the referenced aspects.

(26) FIG. 1A-1D illustrate a frangible fastener 10 configured such that a first end 12 of fastener 10 separates from a second end 14 of fastener 10 responsive to a breaking force. FIG. 1A is a perspective view of fastener 10. FIG. 1B is a section view of fastener 10 (Section 1B-1B shown in FIG. 1A). FIG. 1C is a side view of fastener 10. FIG. 1D is an end view of first end 12 of fastener 10. Fastener 10 may be configured to couple one or more external components that operate structurally and/or frangibly. In some implementations, a head portion 16 of fastener 10 may be configured to engage a first external component and a threaded portion 22 of

fastener 10 may be configured to engage a second external component. By way of a non-limiting example, fastener 10 may secure the exterior cover of an inflatable life raft in a fixed position on an aircraft. In the event the life raft must be deployed, fastener 10 may separate responsive to the breaking force of the inflating raft within the cover. In some implementations, fastener 10 may be used as an alternative to break away wire and/or in other applications. In some implementations, the size, scale, and/or material of fastener 10 may vary depending on the application. As such, the dimensions of the features described herein are not intended to be limiting. In some implementations, the dimensions may be increased and/or decreased from what is described herein such that frangible fastener 10 separates responsive to specifically targeted breaking forces. One of ordinary skill in the art will understand, for example, that the dimensions described herein may be increased (e.g., in an application requiring a larger version of fastener 10) and/or decreased (e.g., in an application requiring a smaller version of fastener 10) by factors of 2, 3, or more from what is described to achieve the targeted breaking forces. In some implementations, fastener 10 may comprise head portion 16, a frangible portion 18 (FIG. 1B, 1C), a tool engagement portion 20 (FIG. 1B), threaded portion 22, and/or other portions.

(27) As shown in FIG. 1A – FIG. 1D, head portion 16 may be located at first end 12 of fastener 10. Head portion 16 may have a generally circular shape with a diameter 24 (FIG. 1A, 1D) of less than about 0.75 inches. Diameter 24 may be between about 0.50 inches and about 0.75 inches. Diameter 24 may be about 0.625 inches. Head portion 16 may comprise a planar side 26 (FIG. 1B, 1C) toward second end 14 of fastener 10, an arcuate side 28 (FIG. 1A-1C) at first end 12 of fastener 10, and/or other components. Head portion 16 may have first thickness 30

(FIG. 1C) at and/or near the outside edge of head portion 16 and a second thickness 32 (FIG. 1C) at and/or near the center of head portion 16. The thickness of head portion 16 may steadily increase from first thickness 30 at and/or near the outside edge to second thickness 32 at and/or near the center. First thickness 30 may be less than about .075 inches. First thickness 30 may be between about .05 inches and about .075 inches. First thickness 30 may be about .064 inches. Second thickness 32 may be less than about .10 inches. Second thickness 32 may be between about .075 inches and about .10 inches. Second thickness 32 may be about .085 inches. The generally circular shape and approximate dimensions of head portion 16 shown in FIG. 1A-1D are not intended to be limiting. Head portion 16 may take any shape that allows it to function as described in the present disclosure.

(28) Head portion 16 may form a channel 34 (FIG. 1A, 1B, 1D) along a first axis 40 (FIG. 1A-1C). Channel 34 may be configured to receive a tightening tool (not shown). Channel 34 may be configured such that the tightening tool passes easily through channel 34. The tightening tool may include a screwdriver, a hex key, a wrench (e.g., an Allen wrench), and/or other tightening tools. In some implementations, channel 34 may be configured such that a 1/8 inch hex key, for example, passes easily through channel 34.

(29) In some implementations, head portion 16 may form a plurality of arcuate radial cuts 35 (FIG. 1A, 1B, 1D). Arcuate radial cuts 35 may be located on an edge of channel 34 and may open toward first axis 40. Arcuate radial cuts 35 may extend from first end 12 through head portion 16 substantially parallel to channel 34 and/or

first axis 40. In some implementations, arcuate radial cuts 35 may have a depth 37 (FIG. 1D) between about .018 inches and about .031 inches.

(30) In some implementations, head portion 16 may form a plurality of peripheral holes 36 (FIG. 1A, 1B, 1D). Peripheral holes 36 may have radii less than about .03 inches. Peripheral holes 36 may have radii between about .01 inches and about .03 inches. Peripheral holes 36 may have radii of about .02 inches. In some implementations, head portion 16 may form depth cuts 38 (FIG. 1A) that correspond to peripheral holes 36. In the example shown in FIG. 1A-1D, there are four peripheral holes 36 and four corresponding depth cuts 38 (though only two depth cuts 38 are shown in FIG. 1A). Peripheral holes 36 and/or depth cuts 38 may be configured to receive safety wiring to secure head portion 16 to the first external component and/or other external components when fastener 10 is installed in a high vibration area, for example. The quantity and approximate dimensions of peripheral holes 36 and/or depth cuts 38 shown in FIG. 1A-1D are not intended to be limiting. Peripheral holes 36 and/or depth cuts 38 may have any dimension in any quantity that allows them to function as described in the present disclosure.

(31) Frangible portion 18 (FIG. 1B, 1C) may be located adjacent to head portion 16 toward second end 14 along first axis 40. Frangible portion 18 may comprise a frangible body 42 (FIG. 1B, 1C) having a plurality of through wall cuts 44 (FIG. 1B, 1C) in a wall thickness (not shown in FIG. 1A-1D) of frangible body 42. Frangible body 42 may be configured to separate at or near through wall cuts 44 responsive to the breaking force. In some implementations, frangible body 42 may have a generally tubular form. Through wall cuts 44 may be radial through wall cuts in the wall thickness of the tube on a plane substantially perpendicular to first axis 40.

Frangible portion 18 may be configured to conduct the tightening tool from channel 34 in the head portion 16 to tool engagement portion 20 through a conduit 46 (FIG. 1B) formed by frangible body 42.

(32) In some implementations, frangible portion 18 may be configured such that the breaking force is between about 5 pounds and about 400 pounds. In some implementations, frangible portion 18 may be configured such that the breaking force is between about 5 pounds and about 100 pounds. In some implementations, frangible portion 18 may be configured such that the breaking force is between about 5 pounds and about 25 pounds. In some implementations, frangible portion 18 may be configured to separate responsive to one or more of a tensile force, a shear force, and/or other forces. In some implementations, frangible portion 18 may be configured to separate responsive to a plurality of forces acting at substantially the same time. In some implementations, frangible portion 18 may be configured such that the breaking force meets technical standard order (TSO) performance standards for a given application (e.g., a 25 pound force limitation typically required for the activation of mechanical emergency systems).

(33) In some implementations, frangible portion 18 may be configured such that the breaking force is proportional to a magnitude of through wall cuts 44. The magnitude of through wall cuts 44 may comprise one or more of a quantity of through wall cuts 44, a cross sectional area of through wall cuts 44, a shape (e.g., rounded corners and/or sharp corners) of through wall cuts 44, and/or other properties of through wall cuts 44. In some implementations, radial cuts 35 in head portion 16 may extent through frangible portion 18. The number of radial cuts 35 may correspond to the number of through wall cuts 44 in frangible body 42. Through

wall cuts 44 may be aligned with corresponding radial cuts 35. Adjusting one or more dimensions (e.g., depth 37) and/or the shape (e.g., arcuate) of radial cuts 35 may change the cross sectional area, the shape, and/or other properties of through wall cuts 44.

(34) In some implementations, frangible portion 18 may be configured such that the breaking force is proportional to the wall thickness of frangible body 42. The wall thickness of frangible body 42 may be adjusted by increasing and/or decreasing a diameter 43 (FIG. 1A, 1D) of channel 34, for example. Increasing diameter 43 may decrease the wall thickness of frangible body 42 and decreasing diameter 43 may increase the wall thickness of frangible body 42, for example.

(35) In some implementations, frangible portion 18 may be configured such that the breaking force is proportional to the inherent material properties of frangible portion 18. The inherent material properties may include one or more of tensile strength, shear strength, and/or other properties of the material used to form frangible fastener 10.

(36) By way of a non-limiting example, FIG. 2A and FIG. 2B illustrate two implementations of frangible body 42. In the first implementation, FIG. 2A, frangible body 42 forms three through wall cuts 44 in a wall thickness 60 of frangible body 42. In the second implementation, FIG. 2B, frangible body 42 forms five through wall cuts 44 in wall thickness 60 of frangible body 42. A progressively thinner wall thickness 60 is shown in the images that correspond to reference numerals 62, 64, 66, and 68. Increasing the number or size of through wall cuts 44 will decrease the breaking force required to separate frangible fastener 10. Decreasing wall thickness 60 will decrease the breaking force required to separate frangible fastener 10.

Accordingly, by adjusting the number and/or size of the through wall cuts 44 and/or the wall thickness 60 the breaking force of the fastener can be adjusted.

(37) Returning to FIG. 1A-1D, tool engagement portion 20 (FIG. 1B) may be configured to engage the tightening tool. Tool engagement portion 20 may be located adjacent to frangible portion 18 toward second end 14 along first axis 40. The location of tool engagement portion 20 may minimize and/or eliminate torsional loading of frangible portion 18 during tightening with the tightening tool. In some implementations, tool engagement portion 20 may be configured such that an axial load (e.g., tension) may be transferred to and/or through frangible portion 18 responsive to head portion 16 engaging an external component (e.g., the first external component described above) as fastener 10 is tightened.

(38) Threaded portion 22 (FIG. 1A-1C) may be located adjacent to tool engagement portion 20 at second end 14 of fastener 10 along first axis 40. In some implementations, threaded portion 22 may be cylindrically shaped. Threaded portion 22 may be configured such that the threads are included on the outside of the cylinder. Threaded portion 22 may be configured to engage a threaded hole in an external component (e.g., the second external component mentioned above).

(39) In some implementations, threaded portion 22 may include a second tool engagement portion 80 (FIG. 1A, 1C) at second end 14 of fastener 10. Second tool engagement portion 80 may be configured to receive a removal tool (not shown). In some implementations, tool engagement portion 20 may be configured to receive the removal tool. In some implementations, the removal tool may be the same as the tightening tool. In some implementations, the removal tool and the tightening tool may be different.

(40) Responsive to a separation of first end 12 from second end 14, threaded portion 22 and/or other portions of frangible fastener 10 may remain in the threaded hole of the external component. Threaded portion 22 and/or other portions of frangible fastener 10 may be removed via tool engagement portion 20 toward first side 12 and/or via tool engagement portion 80 toward second side 14.

(41) In some implementations, an overall length 100 (FIG. 1C) of frangible fastener 10 including head portion 16, a frangible portion 18, a tool engagement portion 20, threaded portion 22, and/or other portions may be less than about 0.5 inches. In some implementations, length 100 may be between about 0.3 inches and about 0.5 inches. In some implementations, length 100 may be about 0.425 inches.

(42) FIG. 3 illustrates a method 300 for fabricating a frangible fastener such that a first end of the fastener separates from a second end of the fastener responsive to a breaking force. The operations of method 300 presented below are intended to be illustrative. In some implementations, method 300 may be accomplished with one or more additional operations not described, and/or without one or more of the operations discussed. Additionally, the order in which the operations of method 300 are illustrated in FIG. 3 and described below is not intended to be limiting.

(43) In some implementations, method 300 may be implemented via one or more processing devices (e.g., a digital processor, an analog processor, a digital circuit designed to process information, an analog circuit designed to process information, a state machine, and/or other mechanisms for electronically processing information) configured to control machining equipment. The one or more processing devices may include one or more devices executing some or all of the operations of method 300 in response to instructions stored electronically on an electronic storage

medium. The one or more processing devices may include one or more devices configured through hardware, firmware, and/or software to be specifically designed for execution of one or more of the operations of method 300. In some implementations, method 300 may be implemented via machining methods, and/or other manufacturing methods.

(44) In some implementations, the frangible fastener (e.g., frangible fastener 10 shown in FIG. 1) may be machined from a single rod shaped piece of stock material. Machining may include cutting, turning, milling, drilling, broaching, and/or other machining operations. In some implementations, the general shape of the frangible fastener may be formed by turning the rod shaped piece of stock material on a lathe, for example. The frangibility features (e.g., through wall cuts 44 shown in FIG. 1, FIG. 2A, and FIG. 2B) may be formed by making a series of drills, for example, into the frangible fastener. The tool engagement slots (e.g., tool engagement portions 20 and/or 80 shown in FIG. 1) may be formed by broaching the rod shaped piece of stock material. In some implementations, fastener 10 may be manufactured via plastic laser sintering, selective laser sintering (SLS), three dimensional printing, and/or other manufacturing methods. In some implementations, no joining is required to manufacture the frangible fastener.

(45) At an operation 302, a head portion may be formed at the first end of the fastener. In some implementations, the head portion may be formed such that the head portion is configured to engage a first external component.

(46) At an operation 304, a frangible portion may be formed adjacent to the head portion toward the second end along a first axis. The frangible portion may comprise a frangible body.

(47) At an operation 306, a plurality of through wall cuts may be formed in a wall thickness of the frangible body. The frangible body may be configured to separate at or near the through wall cuts responsive to the breaking force. In some implementations, the frangible body may be formed such that the frangible body has a generally tubular form and the through wall cuts are radial through wall cuts in the wall thickness of the tube on a plane substantially perpendicular to the first axis. In some implementations, the frangible portion may be formed such that the breaking force is proportional to a magnitude of the through wall cuts. The magnitude of the through wall cuts may comprise one or more of a quantity of the through wall cuts, a cross sectional area of the through wall cuts, a shape of the through wall cuts, and/or other properties of the through wall cuts. In some implementations, the frangible portion may be formed such that the breaking force is proportional to the wall thickness of the frangible body.

(48) At an operation 308, a tool engagement portion may be formed such that the tool engagement portion may engage a tightening tool. The tool engagement portion may be formed adjacent to the frangible portion toward the second end along the first axis. The location of the tool engagement portion may minimize and/or eliminate torsional loading of the frangible portion during tightening with the tightening tool.

(49) At an operation 310, a threaded portion may be formed adjacent to the tool engagement portion at the second end of the fastener along the first axis. In some implementations, the threaded portion may be formed such that the threaded portion is configured to engage a second external component.

(50) Although the present technology has been described in detail for the purpose of illustration based on what is currently considered to be the most practical and

preferred implementations, it is to be understood that such detail is solely for that purpose and that the technology is not limited to the disclosed implementations, but, on the contrary, is intended to cover modifications and equivalent arrangements that are within the spirit and scope of the appended claims. For example, it is to be understood that the present technology contemplates that, to the extent possible, one or more features of any implementation can be combined with one or more features of any other implementation.

What is claimed is:

1. A frangible fastener configured such that a first end of the fastener separates from a second end of the fastener responsive to a breaking force, the fastener comprising:
 - a head portion located at the first end of the fastener;
 - a frangible portion located adjacent to the head portion toward the second end along a first axis, the frangible portion comprising a frangible body having a plurality of through wall cuts in a wall thickness of the frangible body, the frangible body configured to separate at or near the through wall cuts responsive to the breaking force;
 - a tool engagement portion configured to engage a tightening tool, the tool engagement portion located adjacent to the frangible portion toward the second end along the first axis; and
 - a threaded portion located adjacent to the tool engagement portion at the second end of the fastener along the first axis.
2. The system of claim 1, wherein the head portion forms a channel configured to receive the tightening tool.
3. The system of claim 2, wherein the frangible portion is configured to conduct the tightening tool from the channel in the head portion to the tool engagement portion through a conduit formed by the frangible body.

4. The system of claim 1, wherein the head portion is configured to engage a first external component and the threaded portion is configured to engage a second external component.
5. The system of claim 1, wherein the head portion forms a plurality of peripheral holes configured to receive safety wiring.
6. The system of claim 1, wherein the threaded portion includes a second tool engagement portion at the second end of the fastener, the second tool engagement portion configured to receive a removal tool.
7. The system of claim 1, wherein the frangible body has a generally tubular form, and wherein the through wall cuts are radial through wall cuts in the wall thickness of the tube on a plane substantially perpendicular to the first axis.
8. The system of claim 1, wherein the frangible portion is configured such that the breaking force is between about 5 pounds and about 400 pounds.
9. The system of claim 1, wherein the frangible portion is configured to separate responsive to one or more of a tensile force, or a shear force.
10. The system of claim 1, wherein the frangible portion is configured such that the breaking force is proportional to a magnitude of the through wall cuts,

wherein the magnitude of the through wall cuts comprises one or more of a quantity of the through wall cuts, a cross sectional area of the through wall cuts, or a shape of the through wall cuts.

11. The system of claim 1, wherein the frangible portion is configured such that the breaking force is proportional to the wall thickness of the frangible body.
12. The system of claim 1, wherein the frangible portion is configured such that the breaking force is proportional to inherent material properties of the frangible portion.
13. The system of claim 12, wherein inherent material properties include one or more of tensile strength or shear strength of the material used to form the frangible fastener.
14. The system of claim 1, wherein the frangible body forms three through wall cuts in the wall thickness of the frangible body.
15. The system of claim 1, wherein the frangible body forms five through wall cuts in the wall thickness of the frangible body.
16. A method for fabricating a frangible fastener such that a first end of the fastener separates from a second end of the fastener responsive to a breaking force, the method comprising:
 - forming a head portion at the first end of the fastener;

forming a frangible portion adjacent to the head portion toward the second end along a first axis, the frangible portion comprising a frangible body;

forming a plurality of through wall cuts in a wall thickness of the frangible body, the frangible body configured to separate at or near the through wall cuts responsive to the breaking force;

forming a tool engagement portion such that the tool engagement portion is configured to engage a tightening tool, the tool engagement portion formed adjacent to the frangible portion toward the second end along the first axis; and

forming a threaded portion adjacent to the tool engagement portion at the second end of the fastener along the first axis.

17. The method of claim 16, further comprising forming the head portion such that the head portion is configured to engage a first external component, and forming the threaded portion such that the threaded portion is configured to engage a second external component.
18. The method of claim 16, further comprising forming the frangible body such that the frangible body has a generally tubular form and the through wall cuts are radial through wall cuts in the wall thickness of the tube on a plane substantially perpendicular to the first axis.
19. The method of claim 16, further comprising forming the frangible portion such that the breaking force is proportional to a magnitude of the through wall cuts,

wherein the magnitude of the through wall cuts comprises one or more of a quantity of the through wall cuts, a cross sectional area of the through wall cuts, or a shape of the through wall cuts.

20. The method of claim 16, further comprising forming the frangible portion such that the breaking force is proportional to the wall thickness of the frangible body.

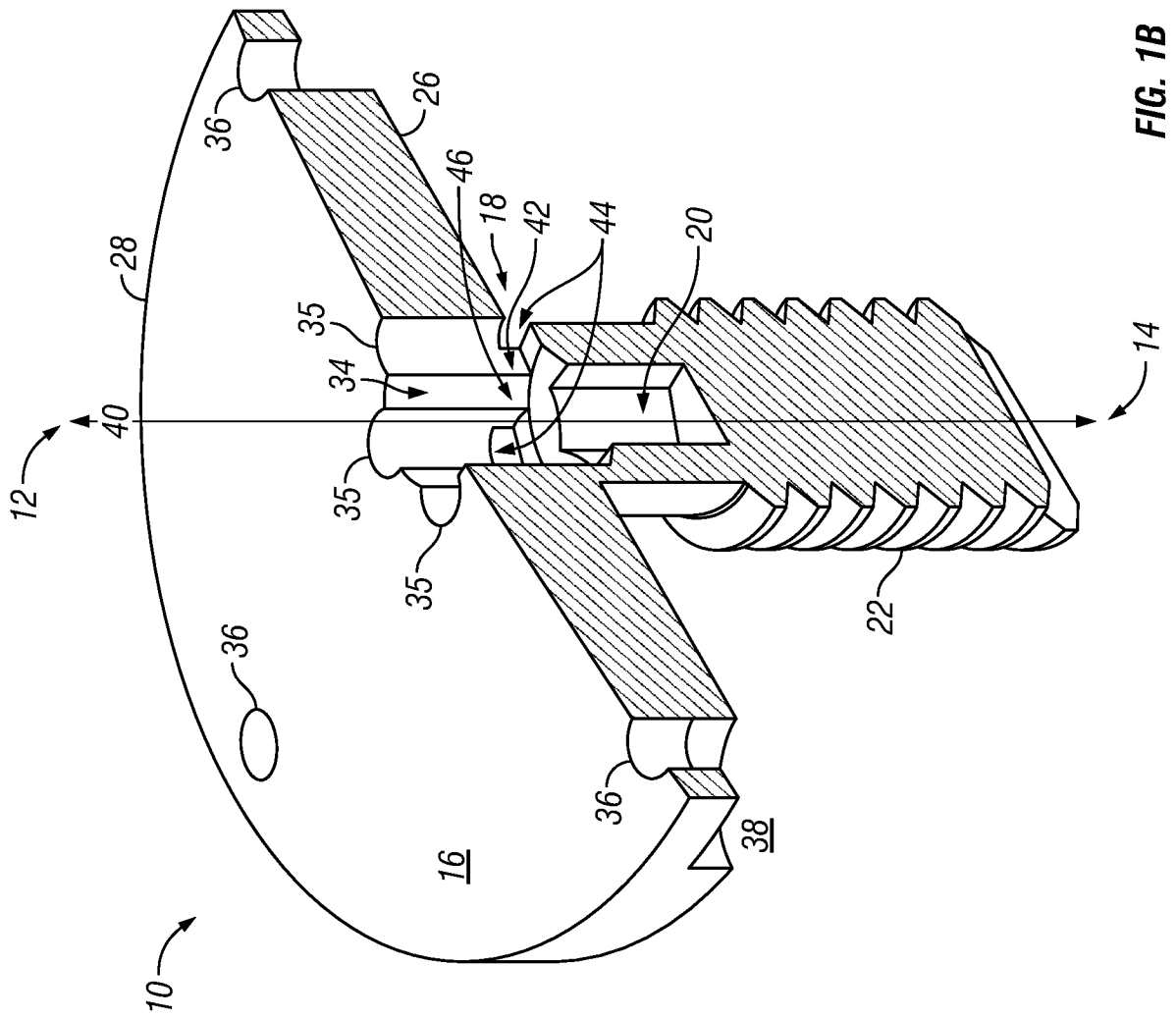

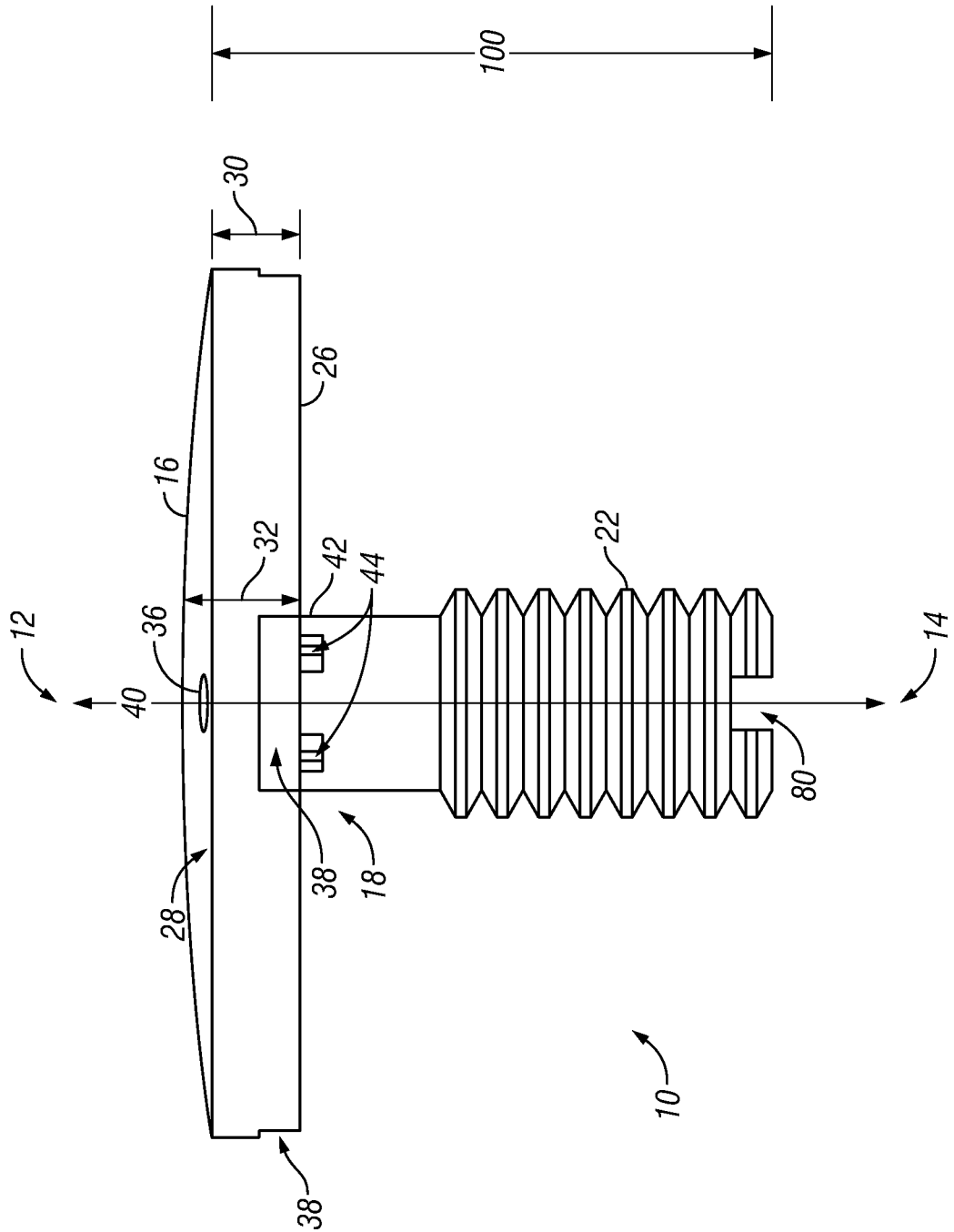

FIG. 1C

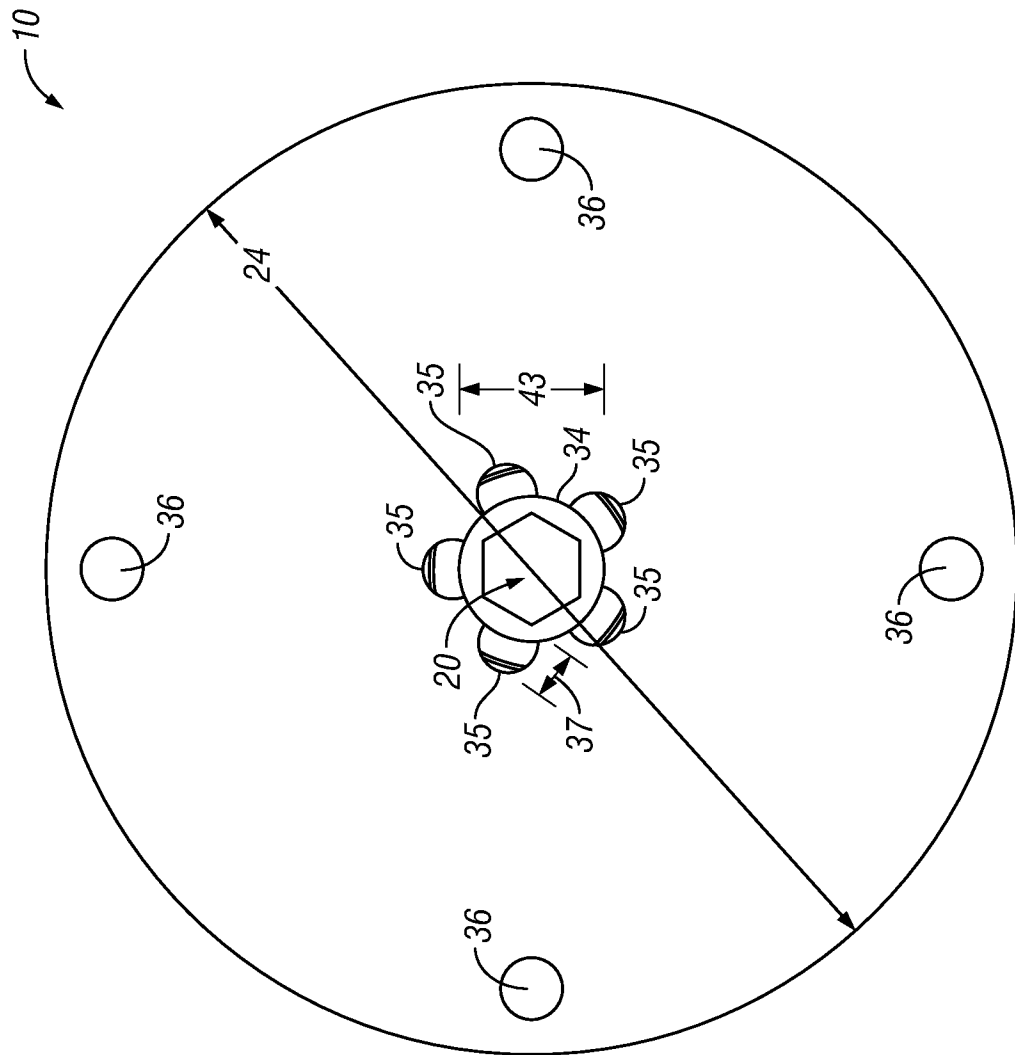
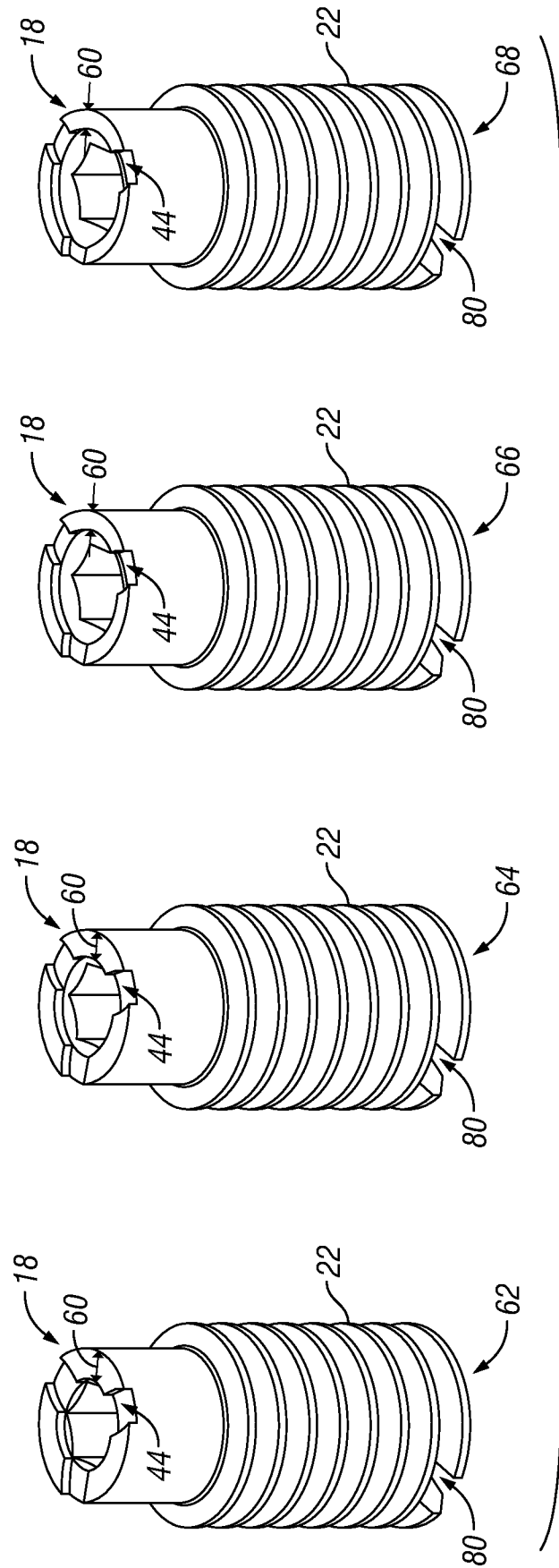

FIG. 1D

5/7



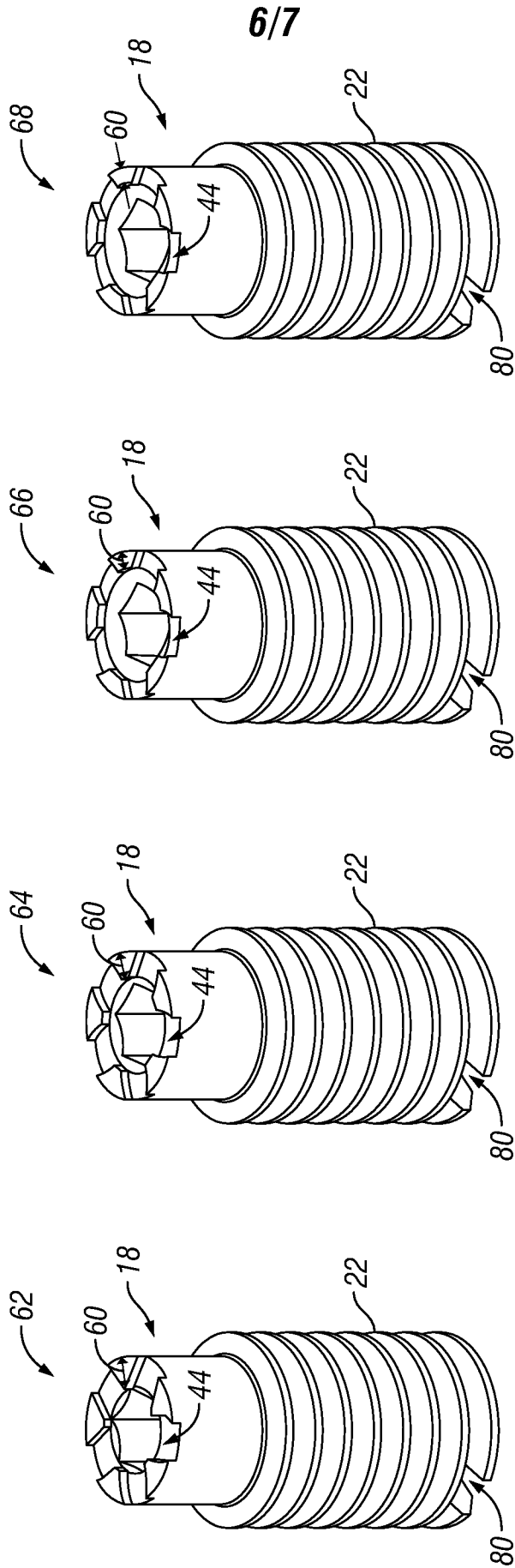

FIG. 2B

7/7

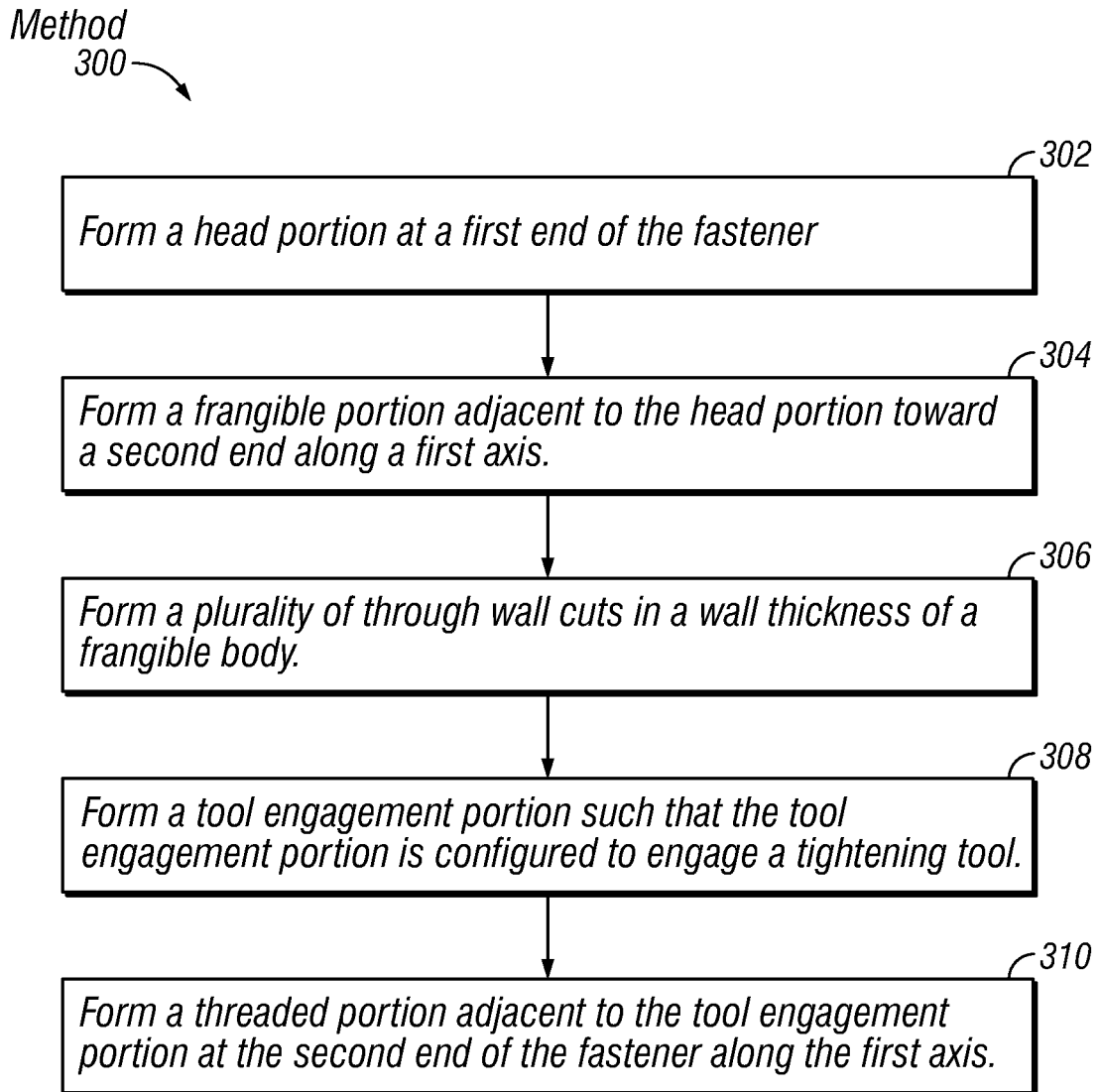

FIG. 3

INTERNATIONAL SEARCH REPORT

International application No.

PCT/US 2014/018776

A. CLASSIFICATION OF SUBJECT MATTER		<i>E05B 39/02 (2006.01)</i> <i>E05B 65/10 (2006.01)</i> <i>E05B 63/00 (2006.01)</i>
According to International Patent Classification (IPC) or to both national classification and IPC		
B. FIELDS SEARCHED		
Minimum documentation searched (classification system followed by classification symbols)		
E05B 39/00-39/02, 63/00, 65/10, F16B 13/08, 31/02, 39/12, G09F 3/03		
Documentation searched other than minimum documentation to the extent that such documents are included in the fields searched		
Electronic data base consulted during the international search (name of data base and, where practicable, search terms used)		
PatSearch (RUPTO internal), Espacenet, RUPTO, USPTO		
C. DOCUMENTS CONSIDERED TO BE RELEVANT		
Category*	Citation of document, with indication, where appropriate, of the relevant passages	Relevant to claim No.
A	US 3512447 A (RUDOLPH MARION VAUGHN) 19.05.1970	1-20
A	US 4987639 A (ROPAK CORPORATION) 29.01.1991	1-20
A	US 2006/0266888 A1 (GOODRICH CORPORATION) 30.11.2006	1-20
<input type="checkbox"/> Further documents are listed in the continuation of Box C. <input type="checkbox"/> See patent family annex.		
* Special categories of cited documents:		
“A”	document defining the general state of the art which is not considered to be of particular relevance	“T” later document published after the international filing date or priority date and not in conflict with the application but cited to understand the principle or theory underlying the invention
“E”	earlier document but published on or after the international filing date	“X” document of particular relevance; the claimed invention cannot be considered novel or cannot be considered to involve an inventive step when the document is taken alone
“L”	document which may throw doubts on priority claim(s) or which is cited to establish the publication date of another citation or other special reason (as specified)	“Y” document of particular relevance; the claimed invention cannot be considered to involve an inventive step when the document is combined with one or more other such documents, such combination being obvious to a person skilled in the art
“O”	document referring to an oral disclosure, use, exhibition or other means	“&” document member of the same patent family
“P”	document published prior to the international filing date but later than the priority date claimed	
Date of the actual completion of the international search		Date of mailing of the international search report
23 June 2014 (23.06.2014)		16 July 2014 (16.07.2014)
Name and mailing address of the ISA/ FIPS Russia, 123995, Moscow, G-59, GSP-5, Berezhkovskaya nab., 30-1		Authorized officer A. Fedotov
Facsimile No. +7 (499) 243-33-37		Telephone No. (495)531-64-81