

(19) World Intellectual Property Organization
International Bureau



(10) International Publication Number
WO 2010/132145 A2

(43) International Publication Date
18 November 2010 (18.11.2010)

(51) International Patent Classification:
B63B 21/04 (2006.01)

(21) International Application Number:
PCT/US2010/027317

(22) International Filing Date:
15 March 2010 (15.03.2010)

(25) Filing Language: English

(26) Publication Language: English

(30) Priority Data:
61/216,166 14 May 2009 (14.05.2009) US

(71) Applicant (for all designated States except US): **ALCOA INC.** [US/US]; 201 Isabella Street, Pittsburgh, PA 15212-5858 (US).

(72) Inventors; and

(75) Inventors/Applicants (for US only): **STULL, Eric, M.** [US/US]; 401 Craigdell Road, Lower Burrell, PA 15068 (US). **BURG, James, T.** [US/US]; 303 Lincoln Avenue, Verona, PA 15147 (US). **SILVIO, Franklin, David** [US/US]; 1311 Pennsylvania Avenue, Natrona Heights, PA 15065 (US). **SPEER, Robert, J.** [US/US]; 325 Delberta Road, Upper Burrell, PA 15068 (US).

(74) Agent: **AGOSTINO, Joseph**; Greenberg Traurig, LLP, C/o Alcoa Inc., Intellectual Property-Buldg. C, Alcoa Tech. Center, 100 Technical Drive, Alcoa Center, PA 15069 (US).

(81) Designated States (unless otherwise indicated, for every kind of national protection available): AE, AG, AL, AM, AO, AT, AU, AZ, BA, BB, BG, BH, BR, BW, BY, BZ, CA, CH, CL, CN, CO, CR, CU, CZ, DE, DK, DM, DO, DZ, EC, EE, EG, ES, FI, GB, GD, GE, GH, GM, GT, HN, HR, HU, ID, IL, IN, IS, JP, KE, KG, KM, KN, KP, KR, KZ, LA, LC, LK, LR, LS, LT, LU, LY, MA, MD, ME, MG, MK, MN, MW, MX, MY, MZ, NA, NG, NI, NO, NZ, OM, PE, PG, PH, PL, PT, RO, RS, RU, SC, SD, SE, SG, SK, SL, SM, ST, SV, SY, TH, TJ, TM, TN, TR, TT, TZ, UA, UG, US, UZ, VC, VN, ZA, ZM, ZW.

(84) Designated States (unless otherwise indicated, for every kind of regional protection available): ARIPO (BW, GH, GM, KE, LS, MW, MZ, NA, SD, SL, SZ, TZ, UG, ZM, ZW), Eurasian (AM, AZ, BY, KG, KZ, MD, RU, TJ, TM), European (AT, BE, BG, CH, CY, CZ, DE, DK, EE, ES, FI, FR, GB, GR, HR, HU, IE, IS, IT, LT, LU, LV, MC, MK, MT, NL, NO, PL, PT, RO, SE, SI, SK, SM, TR), OAPI (BF, BJ, CF, CG, CI, CM, GA, GN, GQ, GW, ML, MR, NE, SN, TD, TG).

[Continued on next page]

(54) Title: TIE DOWN ASSEMBLY

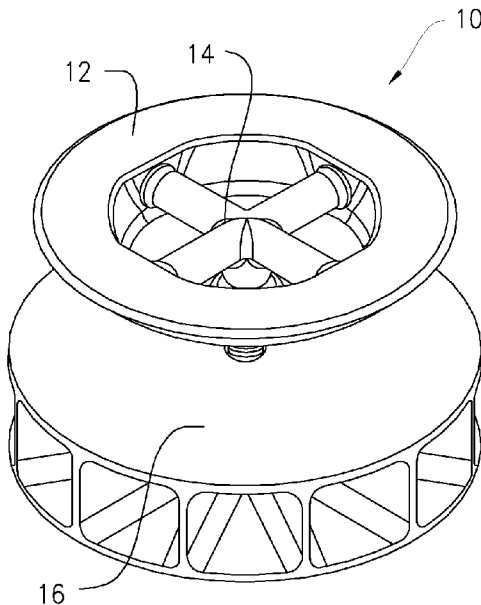

FIG. 1A

(57) Abstract: A tie down assembly (10) including a cup (12), a cross-shaped crossbar (14) that is fastened removably to and positioned within a recess (36) of the cup (12), and a disc-shaped plate (16) that is fastened removably to the cup (12) and/or the crossbar (14). The crossbar (14) is fastened to the cup (12) by a plurality of fasteners (18), while the plate (16) is fastened to the cup (12) and/or the crossbar (14) by at least one fastener (18). The cup (12) is installed within a hole formed within a first surface (94) of a structure (92), and the plate (16) is positioned against an opposite surface (96) of the structure (92). When the plate (16) is attached, a compressive load is introduced and squeezes the first and second surfaces (94, 96) of the structure (92) together, such that most of the load is borne down the center of the fastener (18) attaching the plate (12).

WO 2010/132145 A2

Published:

- *without international search report and to be republished upon receipt of that report (Rule 48.2(g))*

TIE DOWN ASSEMBLY

Cross-Reference to Related Application

This application claims priority from and the benefit of commonly owned, co-
5 pending U.S. Provisional Application Serial No. 61/216,166 entitled "TIE DOWN
ASSEMBLY," filed May 14, 2009, the entirety of which is incorporated herein by
reference.

Technical Field

10 The present invention relates to a tie down assembly and, more particularly, to a
tie down assembly for naval and maritime vessels.

Background Art

Tie down assemblies are commonplace on naval and maritime vessels, as they
15 facilitate the security of cargo, vehicles, such as aircraft, and other heavy items and
equipment. Tie down assemblies are typically installed within a deck of the vessel. Tie
down assemblies must be secure within the deck and endure heavy loads. In addition,
tie down assemblies should be easily repaired and replaced within the deck.

Summary of the Invention

20 In an embodiment, a tie down assembly including a cup, a cross-shaped
crossbar that is fastened removably to and positioned within a recess of the cup, and a
disc-shaped plate that is fastened removably to the cup and the crossbar. In an

embodiment, the crossbar is fastened to the cup by a plurality of threaded fasteners, while the plate is fastened to the cup and the crossbar by a threaded fastener. In an embodiment, the cup is installed within a hole formed within a first surface of a structure, and the plate is positioned against an opposite surface of the structure. In an
5 embodiment, when the plate is attached to the cup and the crossbar by tightening the threaded fastener, a compressive load is introduced, which is borne down the center of the fastener. In an embodiment, the plate is attached to the cup by a plurality of fasteners.

10 **Brief Description of the Drawings**

Reference is made to the following detailed description of the exemplary embodiments considered in conjunction with the accompanying drawings, in which:

FIG. 1A is a top perspective view of a tie down assembly in accordance with an embodiment of the present invention;

15 **FIG. 1B** is a bottom perspective view of the tie down assembly shown in **FIG. 1A**;

FIG. 2A is a top plan view of the tie down assembly shown in **FIG. 1A**;

FIG. 2B is a cross-sectional view, taken along line A-A and looking in the direction of the arrows, of the tie down assembly shown in **FIG. 2A**;

FIG. 3A is an exploded, top perspective view of the tie down assembly shown in
20 **FIG. 1A**;

FIG. 3B is an exploded, bottom perspective view of the tie down assembly shown in **FIG. 1B**;

FIG. 4A is a top perspective view of a cup employed by the tie down assembly shown in FIG. 1A;

FIG. 4B is a top plan view of the cup shown in FIG. 4A;

FIG. 4C is a side elevational view of the cup shown in FIG. 4A;

5 FIG. 4D is a bottom plan view of the cup shown in FIG. 4A;

FIG. 4E is a cross-sectional view, taken along line C-C and looking in the direction of the arrows, of the cup shown in FIG. 4D;

FIG. 4F is a cross-sectional view, taken along line A-A and looking in the direction of the arrows, of the cup shown in FIG. 4B;

10 FIG. 4G is an enlarged view of Detail B of the cup shown in FIG. 4F;

FIG. 4H is a cross-sectional view, taken along line D-D and looking in the direction of the arrows, of the cup shown in FIG. 4F;

FIG. 5A is a top perspective view of a crossbar employed by the tie down assembly shown in FIG. 1A;

15 FIG. 5B is a top plan view of the crossbar shown in FIG. 5A;

FIG. 5C is a side elevational view of the crossbar shown in FIG. 5A;

FIG. 5D is bottom plan view of the crossbar shown in FIG. 5A;

FIG. 5E is a cross-sectional view, taken along line A-A and looking in the direction of the arrows, of the crossbar shown in FIG. 5B;

20 FIG. 5F is an enlarged view of Detail B of the crossbar shown in FIG. 5E;

FIG. 6A is a top perspective view of the cup shown in FIG. 4A and the crossbar shown in FIG. 5A mounted to one another;

FIG. 6B is a top plan view of the cup-crossbar assembly shown in FIG. 6A;

FIG. 6C is a cross-sectional view, taken along line A-A and looking in the direction of the arrows, of the cup-crossbar assembly shown in **FIG. 6B**;

FIG. 7A is a bottom perspective view of a plate employed by the tie down assembly shown in **FIG. 1A**;

5 **FIG. 7B** is a top plan view of the plate shown in **FIG. 7A**;

FIG. 7C is a cross-sectional view, taken along line A-A and looking in the direction of the arrows, of the plate shown in **FIG. 7B**;

FIG. 7D is a cross-sectional view, taken along line B-B and looking in the direction of the arrows, of the plate shown in **FIG. 7C**;

10 **FIG. 7E** is a cross-sectional view, taken along line C-C and looking in the direction of the arrows, of the plate shown in **FIG. 7D**;

FIG. 8 is a cross-sectional view of the tie down assembly shown in **FIG. 2B** mounted to a deck of a vessel;

15 **FIGS. 9A** through **9D** illustrate a tie down assembly in accordance with another embodiment of the present invention;

FIGS. 10A through **10B** illustrate a tie down assembly in accordance with another embodiment of the present invention;

FIGS. 11A through **11B** illustrate a tie down assembly in accordance with another embodiment of the present invention;

20 **FIGS. 12A** through **12D** illustrate a tie down assembly in accordance with another embodiment of the present invention;

FIGS. 13A through **13C** illustrate a tie down assembly in accordance with another embodiment of the present invention;

FIGS. 14A through 14D illustrate a tie down assembly in accordance with another embodiment of the present invention;

FIGS. 15A-15D illustrate a tie down assembly in accordance with another embodiment of the present invention;

5 **FIGS. 16A through 16D** illustrate a tie down assembly in accordance with another embodiment of the present invention;

FIGS. 17A through 17D illustrate a tie down assembly in accordance with another embodiment of the present invention;

10 **FIGS. 18A through 18C** illustrate a tie down assembly in accordance with another embodiment of the present invention;

FIGS. 19A through 19C illustrate a tie down assembly in accordance with another embodiment of the present invention; and

FIGS. 20A through 20C illustrate a tie down assembly in accordance with another embodiment of the present invention.

15

Description of the Embodiments

Referring to **FIGS. 1A and 1B** and **FIGS. 2A and 2B**, in an embodiment, a tie down assembly **10** includes a funnel-shaped cup **12**, a cross-shaped crossbar **14** that is fastened removably to the cup **12**, and a disc-shaped plate **16** that is fastened
20 removably to the cup **12** and the crossbar **14**. Referring to **FIGS. 2B, 3A and 3B**, in an embodiment, the crossbar **14** is fastened to the cup **12** by a plurality of threaded fasteners **18**, while the plate **16** is fastened to the cup **12** and the crossbar **14** by a threaded fastener **20** having an associated washer **22**. In an embodiment, the cup **12**

includes an O-ring 24, whose purpose shall be described hereinafter. In an embodiment, a gasket 26 is positioned between the cup 12 and the crossbar 14 (see in particular FIG. 3A), while each of a plurality of O-rings 28 is positioned between the fasteners 18 and the crossbar 14 (see FIGS. 3A and 3B).

5 In an embodiment, the cup 12 and the plate 16 are each made from aluminum, and the crossbar 14 is made from steel. In other embodiments, the cup 12, the crossbar 14, and the plate 16 are made from other suitable materials known in the art, such as other types of metals or metal alloys. In an embodiment, the cup 12, the crossbar 14, and the plate 16 are produced by forging. In another embodiment, the cup
10 12 and the plate 16 are produced by machining. While the cup 12 is funnel-shaped, it may consist of other shapes and sizes, in accordance with other embodiments. While the crossbar 14 is cross-shaped, it may consist of other shapes and sizes, in accordance with other embodiments. While the plate 16 is disc-shaped, it may consist of other shapes and sizes, in accordance with other embodiments. The features and
15 functions of the cup 12, the crossbar 14, and the plate 16 shall be described hereinafter.

Referring to FIGS. 4A through 4D, in an embodiment, the cup 12 includes a funnel-shaped base 30 having an outer surface 32 and an inner surface 34 that defines a circular-shaped recess 36. In an embodiment, the base 30 tapers from a top end 38 to a bottom end 40 thereof, converging at a stem 42 having a circular-shaped aperture
20 44. In an embodiment, the base 30 further includes a sidewall 46 and a plurality of apertures 48 formed therein that extend from the outer surface 32 to the inner surface 34. In an embodiment, the cup 12 includes four of the apertures 48, which are arranged

in a cross-like pattern (i.e., positioned 90 degrees from each other). In other embodiments, the cup 12 includes more or less than four of the apertures 48.

Still referring to FIGS. 4A through 4D, in an embodiment, the cup 12 includes a circular-shaped flange 50 that surrounds the perimeter of the recess 36. In an embodiment, the flange 50 includes a top surface 52 and a bottom surface 54 opposite thereof. In an embodiment, a circular-shaped groove 56 is formed within the bottom surface 54 of the flange 50 (see specifically FIG. 4G) for receiving the O-ring 24. In an embodiment, a plurality of tabs 58 extend outwardly from the sidewall 46 and are positioned directly below the bottom surface 54 of the flange 50, as shown best in FIGS. 4C through 4E. In an embodiment, the cup 12 includes four of the tabs 58, which are arranged in a cross-like pattern (i.e., 90 degrees from each other). In other embodiments, the cup 12 includes more or less than four of the tabs 58. In an embodiment, each of the tabs 58 is circular in shape (see FIGS. 4C and 4D). In another embodiment, each of the tabs 58 has an oblong shape (see FIGS. 1B and 3B). In other embodiments, each of the tabs 58 consist of other shapes and sizes, e.g., square, rectangular, etc. FIGS. 4E through 4G illustrate additional cross-sectional views of the cup 12.

Referring to FIGS. 5A through 5F, in an embodiment, the crossbar 14 includes a plurality of tubular-shaped members 60, each of which has a first end 62 that intersects with the other ends 62 at a central point 64, and a free end 66. In an embodiment, each of the members 60 lie within the same plane. In an embodiment, each of the members 60 includes a centrally located, circular-shaped aperture 68 formed within the free end 66 thereof, and a circular-shaped groove 70 that surrounds the aperture 68. In an

embodiment, each of the apertures 68 includes internal threads 72 (see FIGS. 5E and 5F) that threadedly engage a corresponding one of the fasteners 18. The crossbar 14 further includes a tubular-shaped stem 74 that extends perpendicularly from the members 60 at the central point 64. In an embodiment, the stem 74 has a first end 76
5 connected to the central point 64 and a free end 78 having a centrally located, circular-shaped aperture 80 (see FIG. 5D). In an embodiment, the aperture 80 includes internal threads (not shown in the Figures) that threadedly engage the fastener 20.

In an embodiment, FIGS. 6A through 6C show the crossbar 14 fastened to the cup 12 by the fasteners 18. In this regard, the crossbar 14 is positioned within the
10 recess 36 of the cup 12, such that one of the apertures 68 of one of the members 60 aligns with a corresponding one of the apertures 48 of the cup 12. In addition, the stem 74 of the crossbar 14 is aligned with the stem 42 of the cup 12, such that the aperture 80 of the stem 74 aligns with the aperture 44 of the cup 12 (see FIG. 6C). In an embodiment, the gasket 26 is positioned at the free end 78 of the stem 74, while each
15 of the O-rings 28 is positioned within a corresponding one of the grooves 70 of one of the members 60 (not shown in FIGS. 6A through 6C, but see FIG. 3A). In an embodiment, each of the fasteners 18 are inserted into a corresponding one of the apertures 48 of the cup 12 and, in turn, threadedly engage a corresponding one of the apertures 68 of the one of the members 60, thereby securing the crossbar 14 to the cup
20 12. In another embodiment, the apertures 68 of the members 60 are filled with a sealant when the fasteners 18 are installed to provide a seal. In an embodiment, the fasteners 18, 20 are threaded bolts.

Referring to **FIGS. 7A** through **7E**, in an embodiment, the plate **16** includes a circular-shaped first surface **82** and a circular-shaped second surface **84** opposite thereof, which are separated by a plurality of ribs **86** that form a plurality of gaps **88**. In an embodiment, each of the first and second surfaces **82, 84** of the plate **16** consists of other shapes and sizes, such as square, elliptical, polygonal. In an embodiment, the ribs **86** provide for strength and stiffness of the plate **16**, and the gaps **88** result a reduction of mass and weight in the plate **16**. In an embodiment, the plate **16** includes a centrally located, circular-shaped counterbore **90** that extends from the first surface **82** to the second surface **84**. In an embodiment, the diameter of the counterbore **90** at the second surface **84** is greater than the diameter of the counterbore **90** at the first surface **82**. In an embodiment, the fastener **20** is inserted into the counterbore **90** of the plate **16** from the second surface **84** and to the first surface **82**, and threadedly engages the aperture **80** of the stem **74** of the crossbar **14**.

Referring to **FIG. 8**, in an embodiment, the tie down assembly **10** is installed in a deck **92** of a vessel having an upper layer **94** and a lower layer **96**. In an embodiment, the deck **92** is made from aluminum. In other embodiments, the deck **92** is made from other materials, such as metals and metal alloys. In an embodiment, the deck **92** includes a solid portion(s). In another embodiment, the deck **92** is corrugated. In another embodiment, the deck **92** is a multi-hollow extrusion. In another embodiment, the deck **92** is characterized by a fabricated, complex geometrical decking structure. In an embodiment, a hole is bored into the upper and lower layers **94, 96** of the deck **92** (not shown in the Figures). In an embodiment, the diameter of the hole is substantially equal to the diameter of the base **30** of the cup **12**. In an embodiment, additional holes,

which are smaller in size than that of the aforesaid hole, are bored into the upper layer 94 of the deck 92, and are sized and shaped and arranged to accommodate the receipt of the tabs 58 of the cup 12 (not shown in the Figures). The crossbar 14 is secured to the cup 12 as described above, and the base 30 of the cup 12 is positioned within the aforesaid larger hole, while the tabs 58 are positioned within the aforesaid smaller holes (not shown in the Figures). As a result, the flange 50 of the cup 12 rests on the top surface of the upper layer 94 of the deck 92 and lies flush, leaving the crossbar 14 exposed within the upper layer 94.

In an embodiment, the plate 16 is positioned beneath the lower layer 96 of the deck 92, whereby the first surface 82 of the plate 16 is juxtaposed with the lower layer 96. In an embodiment, the fastener 20 is inserted within the counterbore 90 of the plate 20 and, in turn, the aperture 44 of the cup 12 and threadedly engages the aperture 80 of the stem 74 of the crossbar 14. In an embodiment, as the fastener 20 is tightened, a compressive load is introduced and forces the upper and lower layers 94, 96 of the deck 92 together. In an embodiment, the tie down assembly 10 is preloaded when installed, resulting in no gaps between the flange 50 of the cup 12 and the upper layer 94 of the deck 92, and between the plate 16 and the lower layer 96 of the deck 92. That is, the fastener 20 is preloaded to a predetermined torque rating to produce a preloaded compressive assembly, thereby maintaining the assembly 10 within the deck 92 during use. In an embodiment, the fastener 20 is preloaded to a torque rating in the range of approximately 150 ft.-lbs. to approximately 250 ft.-lbs. In an embodiment, the fastener 20 is preloaded to a torque rating of approximately 190 ft.-lbs. In an embodiment, all of the preload is borne through the fastener 20 in the span between the cup 12 and the

washer **22**. Above this span, in an embodiment, the load splits, with approximately half of the load goes into the crossbar **14** then out to the flange **50** of the cup **12** and into the deck **92**, while approximately the other half of the load goes through the base **30** of the cup **12** then out to the flange **50** and into the deck **92**.

5 In an embodiment, a seal is formed between the tie down assembly **10** and the deck **92**, which prevents corrosion from foreign substances, such as seawater. In an embodiment, the flange **50** of the cup **12** lies substantially flush with the upper layer **94** of the deck **92**, minimizing the protrusion of the assembly **10** above the deck **92**. In an embodiment, the tabs **58** of the cup **12** prevent rotation of the tie down assembly **10**
10 relative to the deck **92**, thereby maintaining the stability of the assembly **10** during use.

 In an embodiment, the crossbar **14** is sized and shaped to accommodate the receipt of various tie down connectors, such as hooks, clips, cables, rope, etc. (not shown in the Figures). In an embodiment, the load endured by the tie down assembly **10** is borne by the fastener **20** as described above, and shear is borne by the fasteners
15 **18**.

 In an embodiment, in the event the tie down assembly **10** requires repair or replacement, it is removed from the deck **92** by unfastening the fastener **20** from the crossbar **14** and the cup **12**. As a result, the cup **12** and crossbar **14** assembly can be lifted out of the hole in the upper layer **94** of the deck **92**.

20 In an embodiment, the cup **12** and the plate **16** are made from aluminum, while the crossbar **14** is made from steel, resulting in a savings in weight of approximately 50% as a compared to if the cup **12**, the crossbar **14**, and the plate **16** were each made from steel.

In an embodiment, the crossbar **14** is coated with a coating for preventing wear from where aforesaid connectors engage the crossbar **14**. In an embodiment, the coating composition consists of an aluminum/stainless steel blend manufactured by Alcoa, Inc., and which is the subject of U.S. Patent Nos. 5,884,388 and 6,290,032, 5 which are incorporated herein by reference herein in their entireties. In other embodiments, the coating includes an electroless nickel phosphorous coating, such as NIBORE™ brand of coating, a diamond chrome coating, a hard chrome coating, or a nickel cobalt coating, all of which are supplied by Bales Mold Service Inc. of Downers Grove, Illinois. In other embodiments, the coating includes a wear-resistant cubic boron 10 nitride, hard powder coating, such as TUFFTEK® brand of coating supplied by NanoMech, LLC d/b/a Duralor of Springdale, Arkansas. In other embodiments, other suitable coatings that prevent wear and are known in the art may be utilized.

Pull tests on the tie down assembly **10** were performed using strain gauged test hooks on the crossbar **14**, and a load of 32,000 pounds was met. Visual inspection of 15 the tie down assembly **10** was performed and no yielding of material was evident. Further visual inspection was performed on the fasteners **18** and **20**, which revealed no evidence of yielding. In addition, tie down leak testing was performed to verify that the gasket **26** and the O-rings **24** and **28** did not leak. In this regard, a no pull-leak test was performed by filling the cup **12** with water and subsequently inspected. The results 20 revealed no leakage. Also, a 32,000 pound pull-leak test was performed by submerging the tie down assembly **10** in water. Testing was conducted for 10 minutes and no leaks were detected. This was followed by rotating the tie down assembly **10** ninety (90) degrees and testing for 15 minutes, resulting in no leakage.

FIGS. 9A through 9D illustrate another embodiment of the present invention, in which a tie down assembly **110** includes a cup **112**, a crossbar **114**, and a plate **116** that is secured to the cup **112** and the crossbar **114** by a fastener **120**. In an embodiment, the tie down assembly **110** has a structure and function that are similar to the tie down assembly **10**, except that the former includes a solid disc-shaped plate **116** having no ribs or gaps. The tie down assembly **110** is installed within the deck **92** in a manner similar to that described above with respect to the tie down assembly **10** (see **FIG. 9D**).

FIGS. 10A and 10B illustrate another embodiment of the present invention, in which a tie down assembly **210** includes a cup **212**, a crossbar **214** mounted within a recess **236** of the cup **212** by a plurality of fasteners **218**, and a tubular-shaped sleeve **217**. In an embodiment, the cup **212** and the sleeve **217** are made from aluminum, while the crossbar **214** and the fasteners **218** are made from stainless steel. In an embodiment, the cup **212** is welded to one end of the sleeve **217** by welding means known in the art (e.g., MIG, etc.). In an embodiment, a bottom cap (not shown in the Figures) is welded to another end of the sleeve. In an embodiment, the tie down assembly **210** is welded to an aluminum deck (not shown in the Figures).

FIGS. 11A and 11B illustrate another embodiment of the present invention, in which a tie down assembly **310** a cup **312**, a crossbar **314** mounted within a recess **336** of the cup **312** by a plurality of fasteners **318**, a tubular-shaped sleeve **317**, and a bottom plate **316** attached to the sleeve **317**. In an embodiment, the tie down assembly **310** is identical to the tie down assembly **210**, except that the recess **336** of the cup **312**

has a greater diameter and volume in order to accommodate a larger sized crossbar **314**.

FIGS. 12A and 12B illustrate another embodiment of the present invention, in which a tie down assembly **410** includes a cup **412**, a crossbar **414** mounted within a recess **436** of the cup **412** by a plurality of fasteners **418**, a tubular-shaped sleeve **417**, and a bottom cap **416**. In an embodiment, the cup **412**, the sleeve **417**, and the cap **416** are made from aluminum, while the crossbar **414** and the fasteners **418** are made from stainless steel. In an embodiment, the cup **412** is welded to one end of the sleeve **417** and the cap **416** is welded to another end of the sleeve **417** by welding means known in the art (e.g., friction welding, etc.). In an embodiment, the tie down assembly **410** is welded to an aluminum deck **92**.

FIGS. 13A and 13C illustrate another embodiment of the present invention, in which a tie down assembly **510** includes a cup **512**, a crossbar **514** mounted within a recess **536** of the cup **512**, a tubular-shaped sleeve **517**, and a bottom cap **516**. The crossbar **514** includes a plurality of members **560** and a ring **561** that surrounds the members **560**. In an embodiment, the cup **512**, the sleeve **517**, and the cap **516** are made from aluminum, while the crossbar **514** is made from steel. The crossbar **514** is positioned with the recess **536** of the cup **512** and attached thereto by any attachment means known in the art (e.g., friction stir welding, adhesives). In an embodiment, the crossbar **514** and the cup **512** are attached to one another by mechanical means, such as keying. In an embodiment, the cup **512** and the cap **516** are welded to the sleeve **517**. In an embodiment, the tie down assembly **510** is welded to an aluminum deck (not shown in the Figures).

FIGS. 14A through 14C illustrate another embodiment of the present invention, in which a tie down assembly **610** includes a ring-shaped collar **611**, a crossbar **614** attached to the collar **611**, a funnel-shaped cover **612** having a recess **636**, a sleeve **617**, and a cap **616**. In an embodiment, the collar **611**, the crossbar **614**, the cover **612**, the sleeve **617**, and the cap **616** are made from aluminum. In an embodiment, the crossbar **614** is welded within slots **615** formed within a bottom surface of the collar **611**, and the cover **612** envelopes the crossbar **614**, which is positioned within the recess **636**, and is welded to the bottom surface of the collar **611**. In an embodiment, the collar **611** and the cap **616** are welded to the sleeve **617**. In an embodiment, the tie down assembly **610** is welded to an aluminum deck (not shown in the Figures).

FIGS. 15A through 15D illustrate another embodiment of the present invention, in which a tie down assembly **710** includes a ring-shaped collar **711**, a crossbar **714** attached to the collar **711**, a funnel-shaped cover **712** having a recess **736**, and a sleeve **717**. In an embodiment, the collar **711**, the crossbar **714**, the cover **712**, and the sleeve **717** are made from aluminum. In other embodiments, the cover **712** is made from other metallic or non-metallic materials. In an embodiment, the crossbar **714** is welded to a bottom surface of the collar **711**, and the cover **712** envelopes the crossbar **714** and is welded to the bottom surface of the collar **711**. In an embodiment, the collar **711** and the cap **716** are welded to the sleeve **717**. In an embodiment, the tie down assembly **710** is welded to an aluminum deck (not shown in the Figures).

FIGS. 16A through 16D illustrate another embodiment of the present invention in which, a tie down assembly **810** includes a cylindrical-shaped base **812** having a circular-shaped recess **836**, and a crossbar **814** positioned within the recess **836**. In an

embodiment, the tie down assembly **810** includes a hollow interior section **811** having ribbing **813** and a plurality of tabs **815**. The ribbing **813** provides strength and stiffness, while allowing for mass reduction, of the tie down assembly **810**. In an embodiment, the tie down assembly **810** is a unitary unit made by investment casting. In an embodiment, a circular-shaped close-out cover **816** is welded to the tabs **815**. In an embodiment, a wear-coating substance is added to the crossbar **814** (not shown in the Figures). In an embodiment, the tie down assembly **810** is welded to an aluminum deck (not shown in the Figures).

FIGS. 17A through 17D illustrate another embodiment of the present invention, including a tie down assembly **910** includes a cylindrical-shaped base **912** having a recess **936**, and a crossbar **814** positioned within the recess **936**. In an embodiment, the tie down assembly **810** includes a hollow interior section **911** having a tab **915**. In an embodiment, the tie down assembly **910** is a unitary unit made by machining. In an embodiment, a circular-shaped close-out cover **916** is welded to the tab **915**. In an embodiment, a wear-coating substance is added to the crossbar **914** (not shown in the Figures). In an embodiment, the tie down assembly **910** is welded to an aluminum deck (not shown in the Figures).

FIGS. 18A through 18C illustrate another embodiment of the present invention, in which a tie down assembly **1010** includes a tubular-shaped sleeve **1012**, a collar **1011**, and a crossbar **1014**. In an embodiment, the collar **1011** includes two portions **1013a**, **1013b** that are sized and shaped to mate with one another, forming a circular-shaped groove **1015**. In an embodiment, the crossbar **1014** includes a plurality of members **1060** and a ring **1061** that encircles the members **1060**. In an embodiment, the ring

1061 is received within the groove 1015 of the collar 1011, thereby interlocking the crossbar 1014. In an embodiment, a bottom cap 1016 is welded to the sleeve 1012. In an embodiment, collar 1011, the crossbar 1014, and the sleeve 1012 are made from aluminum. In another embodiment, the crossbar 1014 is made from steel. In an embodiment, the crossbar 1014 is welded to the sleeve 1012. In an embodiment, the tie down assembly 1010 is welded to an aluminum deck (not shown in the Figures).

FIGS. 19A through 19C illustrate another embodiment of the present invention, in which a tie down assembly 1110 includes a tubular-shaped housing 1012 having a recess 1136 and a flange 1050, a cross-shaped crossbar 1114 mounted within the recess 1136 of the housing 1012 by a plurality of fasteners 1118, and a collar 1016 mounted to the housing by a plurality of tapered pins or keys (not specifically shown in the Figures), which compress the assembly 1110 together. In an embodiment, the housing 1012 includes a hollow, interior section 1111 that includes ribbing 1113 to provide stiffness and strength and allows for mass reduction. In an embodiment, the housing 1012 and the collar 1016 are made from aluminum, while the crossbar 1114 is made from steel. In an embodiment, the housing 1012 and the collar 1016 are machined. The tie down assembly 1110 is fastened to the aluminum deck 92 (see FIG. 19C).

FIGS. 20A through 20C illustrate another embodiment of the present invention, in which a tie down assembly 1210 includes a cup 1212, a crossbar 1214, and a plate 1216 that is secured to the cup 1212 by a plurality of fasteners 1218. In an embodiment, the tie down assembly 1210 has a structure and function that are similar to the tie down assembly 10, except that the fasteners 1218 attaching the plate 1216 to

the cup **1212** do not engage the crossbar **1214**. The tie down assembly **1210** is installed within the deck **92** in a manner similar to that described above with respect to the tie down assembly **10** (see **FIG. 9D**).

It will be understood that the tie down assemblies described herein are merely
5 exemplary and that a person skilled in the art may make many variations and
modifications without departing from the full spirit and the scope of the embodiment
described herein. For example, in an embodiment, the tie down assembly **10** includes
failsafe components that enable the assembly **10** to fail prior to damaging the decking if
overloaded, thereby saving high repair costs. In addition, in one or more embodiments,
10 the tie down assemblies may be utilized in environments other than naval and maritime
vessels, such as, for example, rail, aerospace, and motor vehicle transportation.
Accordingly, all such variations and modifications are intended to be included within the
scope of the invention as defined in the appended claims.

CLAIMS

What is claimed is:

1. A tie-down assembly adapted to be installed in a structure, comprising:

a cup having a first end, a second end opposite the first end, a recess formed
5 within the first end and defining a sidewall having a plurality of apertures formed therein,
a centrally-located aperture formed within the recess at the second end, and a stem
extending from the second end and including an aperture that extends the length of the
stem, the aperture of the stem being aligned with the centrally-located aperture of the
recess;

10 a crossbar having a plurality of members each of which includes a first end
having an aperture formed axially therein, each of the plurality of members being joined
to one another at a central point, and a stem extending perpendicularly from the
centrally point of the plurality of members, the stem including a first end with an aperture
formed axially therein, the crossbar being positioned within the recess of the cup such
15 that each of the apertures of the plurality of members of the crossbar aligns with a
corresponding one of the apertures of the sidewall of the cup, each of the aligned
apertures of the sidewall of the cup and the apertures of the plurality of members are
sized and shaped to receive one of a first plurality of fasteners, and the stem of the
crossbar aligns with the stem of the cup such that the aperture of the stem of the
20 crossbar aligns with the aperture of the stem of the cup, the aligned aperture of the
stem of the crossbar and the aperture of the stem of the cup are sized and shaped to
receive a second fastener; and

a support plate having a first surface, a second surface opposite the first surface, and an aperture extending from the first surface to the second surface, the plate being attached removably to the crossbar such that the aperture of the plate is sized and shaped to receive the second fastener.

5

2. The tie down assembly of Claim 1, wherein the structural member includes a first surface and a second surface opposite the first surface, the first surface including a first hole formed therein that is sized and shaped to receive the cup, and wherein the first surface of plate is juxtaposed with the lower surface of the structure.

10

3. The tie down assembly of Claim 2, wherein the lower surface of the structure includes a second hole formed therein that is sized and shaped to receive the second fastener.

15

4. The tie down assembly of Claim 3, wherein said cup includes a flange surrounding a perimeter of the recess and having a top surface and a bottom surface opposite the top surface, the flange of cup rests on the first surface of the structure.

20

5. The tie down assembly of Claim 4, wherein the bottom surface of the flange of the cup includes a groove formed therein that is sized and shaped to receive an O-ring.

6. The tie down assembly of Claim 5, wherein the sidewall of the cup includes a plurality of tabs extending outwardly therefrom and positioned proximate to the bottom

surface of the flange of the cup, and wherein the first surface of the structure includes a plurality of notches formed therein, each of said plurality of notches is sized and shaped to receive a corresponding one of the plurality of tabs of the cup so as to inhibit rotation of the tie down assembly relative to the first surface of the structure.

5

7. The tie-down assembly of Claim 1, wherein each of the apertures of the plurality of members includes internal threads for threadedly receiving a corresponding one of the plurality of first fasteners, and wherein the aperture of the stem of the crossbar includes internal threads for threadedly receiving the second fastener.

10

8. The tie-down assembly of Claim 1, wherein the cup and the plate are each made from aluminum, and the crossbar is made from steel.

9. The tie down assembly of Claim 1, wherein the plurality of members includes four
15 members.

10. The tie down assembly of Claim 9, wherein each of the plurality of members of the crossbar extend substantially in the same plane.

20 11. The tie down assembly of Claim 10, further comprising a gasket positioned between the first end of the stem and the recess of the cup.

12. The tie down assembly of Claim 11, wherein each of the first ends of the plurality of members includes a groove that is sized and shaped to receive an O-ring.

13. The tie down assembly of Claim 1, wherein the first and second surfaces of the
5 plate are separated by a plurality of ribs.

14. The tie down assembly of Claim 1, wherein the structure is made from aluminum.

15. The tie down assembly of Claim 14, wherein the structure includes a deck of a
10 vessel.

16. A tie down assembly adapted to be installed in a structure, comprising: a cup having a first end, a second end opposite the first end, a recess formed within the first end and defining a sidewall having a plurality of apertures formed therein, and a
15 centrally-located aperture formed within the recess at said second end; a crossbar having a plurality of members extending each of which includes a first end having an aperture formed axially therein, each of the plurality of members being joined to one another at a central point, and a stem extending perpendicularly from the central point of the plurality of members, the stem including a first end with an aperture formed axially
20 therein, the crossbar being positioned within the recess of the cup such that each of the apertures of the plurality of members of the crossbar aligns with a corresponding one of the apertures of the sidewall of the cup, each of the aligned apertures of the sidewall of the cup and the apertures of the plurality of members are sized and shaped to receive

one of a first plurality of fasteners, and the stem of the crossbar aligns with the aperture of the recess of the cup, the aligned aperture of the stem of the crossbar and the aperture of the recess of the cup are sized and shaped to receive a central fastener; and a plate having a first surface and second surface opposite the first surface, the plate being attached removably to the cup by a second plurality of fasteners.

17. The tie down assembly of Claim 16, wherein the structural member includes a first surface and a second surface opposite the first surface, the first surface including a first hole formed therein that is sized and shaped to receive the cup, and wherein the first surface of plate is juxtaposed with the lower surface of the structure.

18. The tie down assembly of Claim 17, wherein said cup includes a flange surrounding a perimeter of the recess and having a top surface and a bottom surface opposite the top surface, the flange of cup rests on the first surface of the structure.

19. The tie down assembly of Claim 18, wherein the bottom surface of the flange of the cup includes a groove formed therein that is sized and shaped to receive an O-ring.

20. The tie down assembly of Claim 19, wherein the sidewall of the cup includes a plurality of tabs extending outwardly therefrom and positioned proximate to the bottom surface of the flange of the cup, and wherein the first surface of the structure includes a plurality of notches formed therein, each of said plurality of notches is sized and shaped

to receive a corresponding one of the plurality of tabs of the cup so as to inhibit rotation of the tie down assembly relative to the first surface of the structure.

21. The tie-down assembly of Claim 16, wherein each of the apertures of the plurality
5 of members includes internal threads for threadedly receiving a corresponding one of the plurality of first fasteners, and wherein the aperture of the stem of the crossbar includes internal threads for threadedly receiving the second fastener.

22. The tie-down assembly of Claim 16, wherein the cup and the plate are each
10 made from aluminum, and the crossbar is made from steel.

23. The tie down assembly of Claim 16, wherein the plurality of members includes four members.

15 24. The tie down assembly of Claim 23, wherein each of the plurality of members of the crossbar extend substantially in the same plane.

25. The tie down assembly of Claim 24, further comprising a gasket positioned between the first end of the stem and the recess of the cup.

20

26. The tie down assembly of Claim 25, wherein each of the first ends of the plurality of members includes a groove that is sized and shaped to receive an O-ring.

27. The tie down assembly of Claim 16, wherein the structure is made from aluminum.

28. The tie down assembly of Claim 27, wherein the structure includes a deck of a
5 vessel.

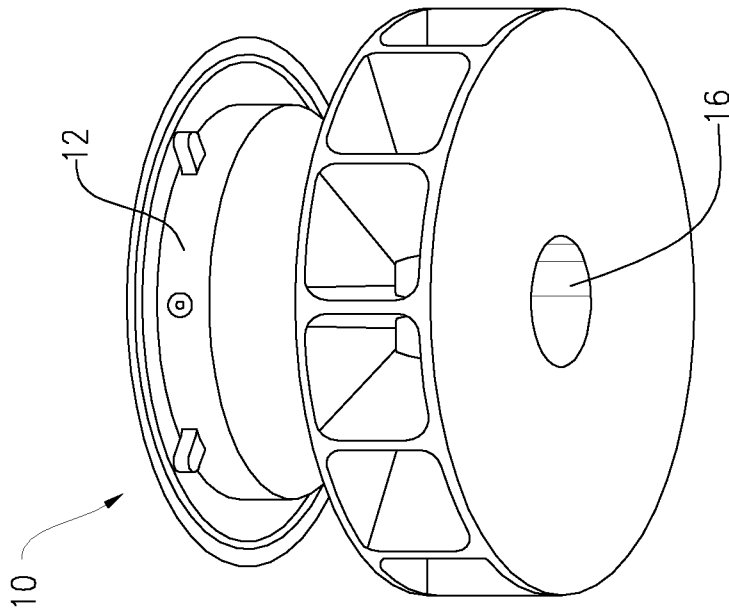

FIG. 1A

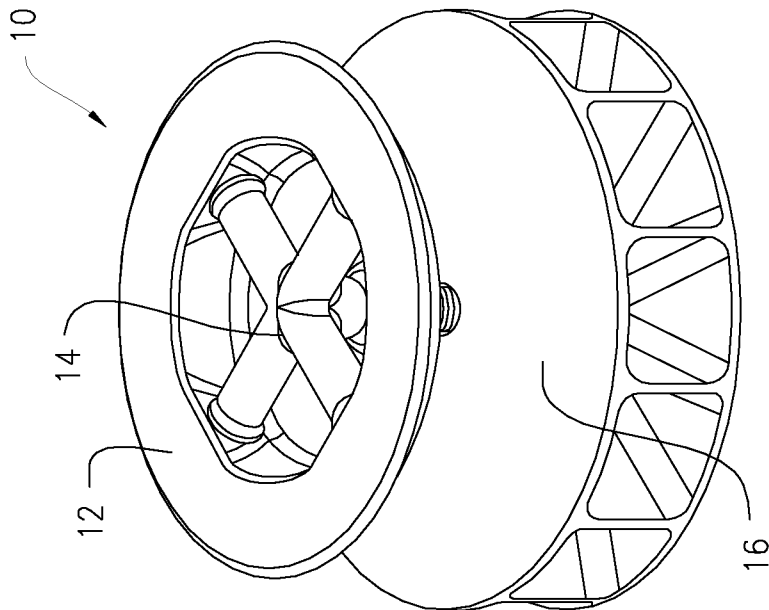

FIG. 1B

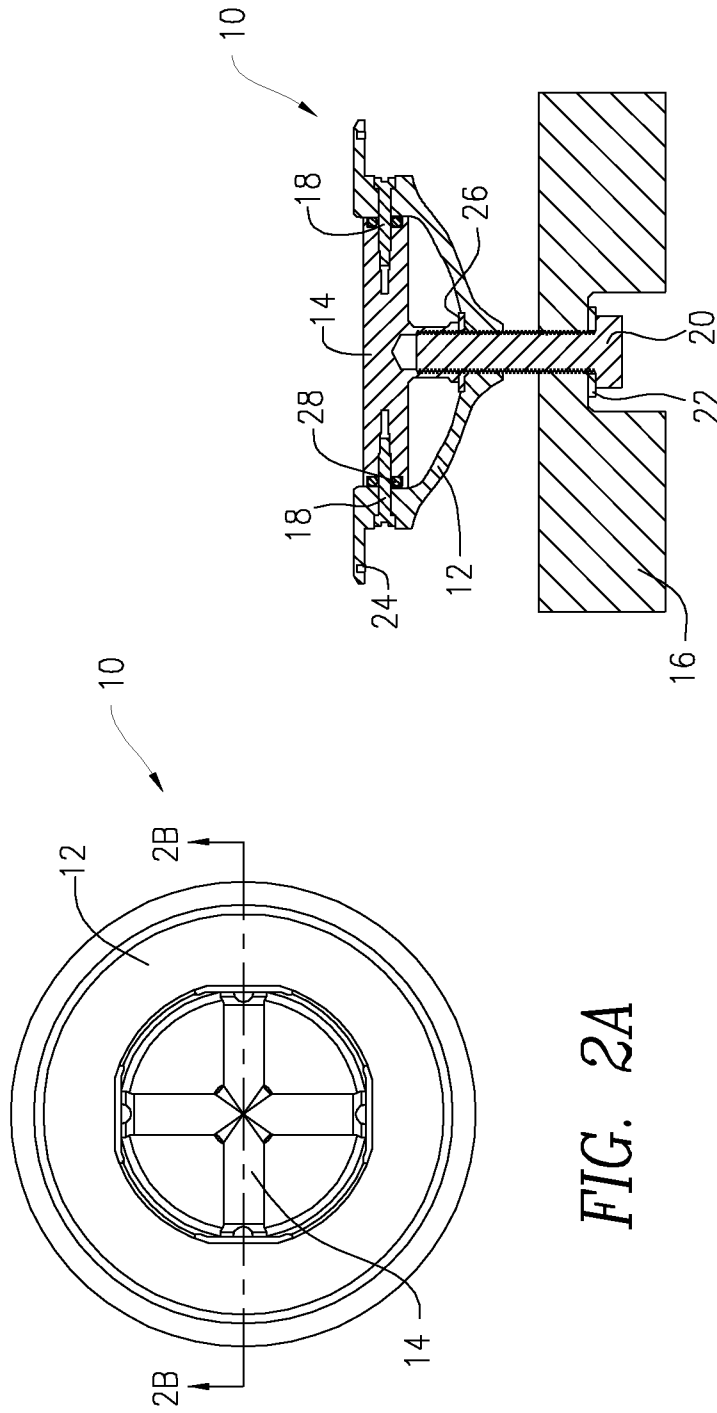

FIG. 2A

FIG. 2B

3/25

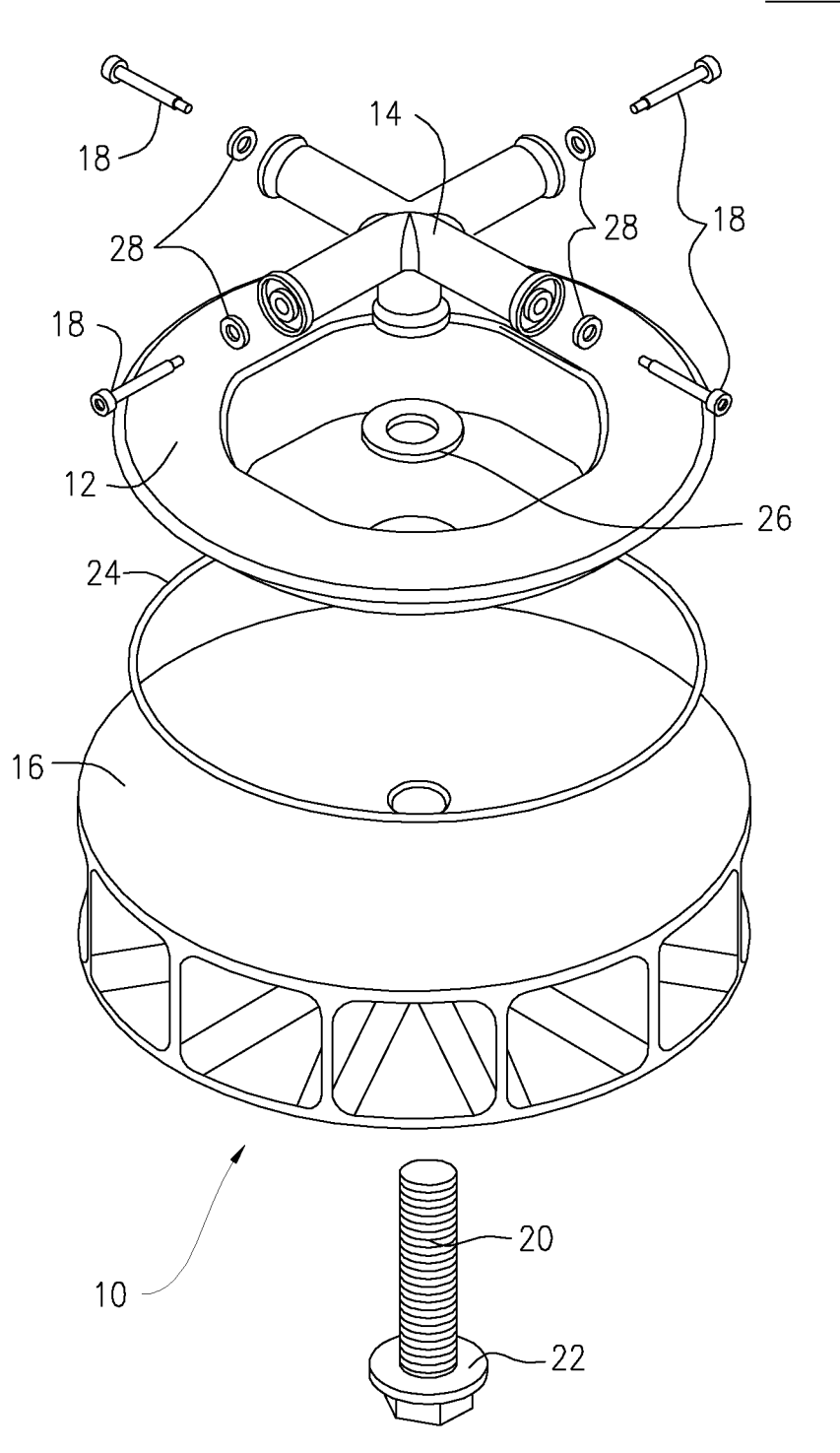

FIG. 3A

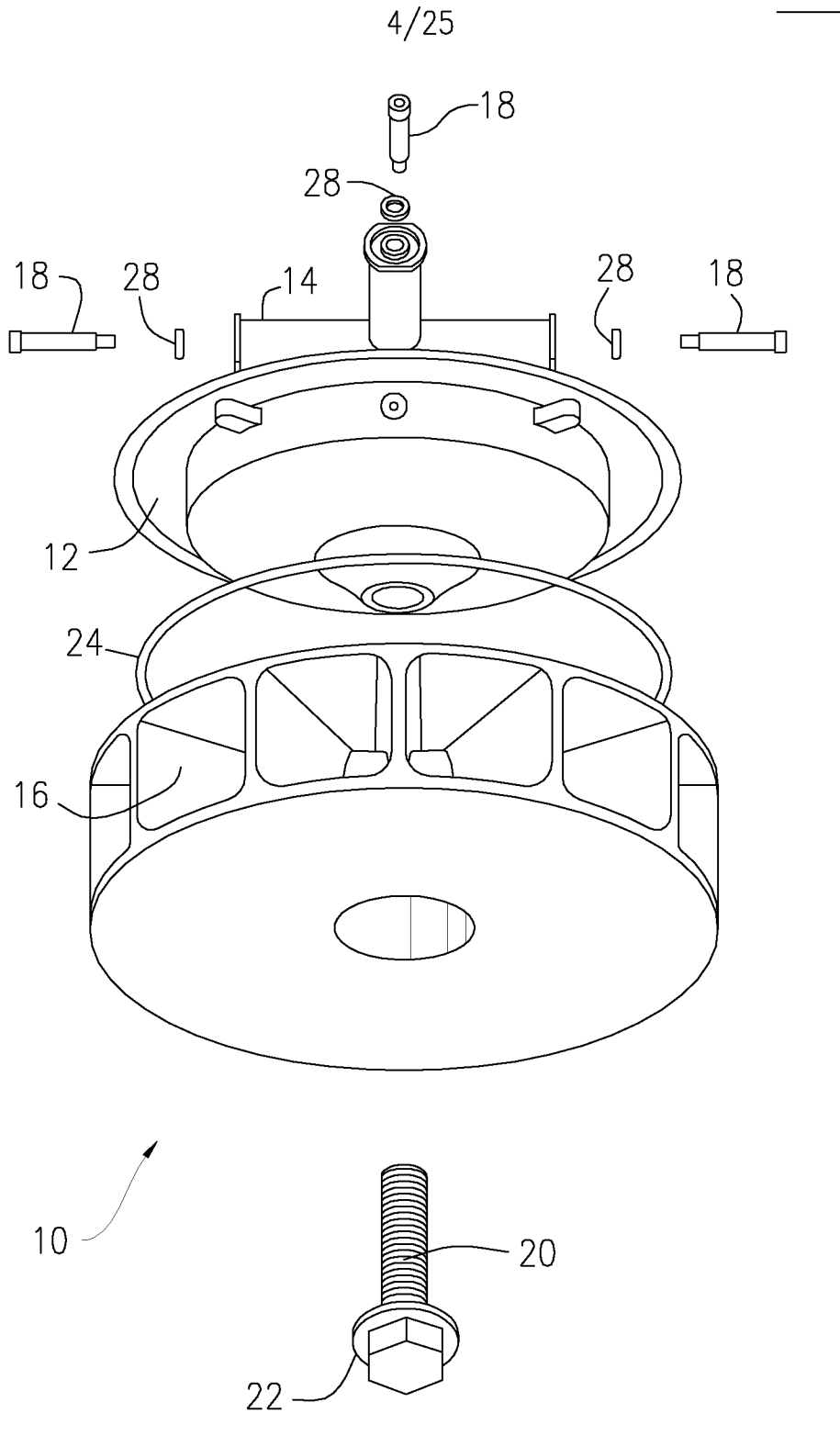

FIG. 3B

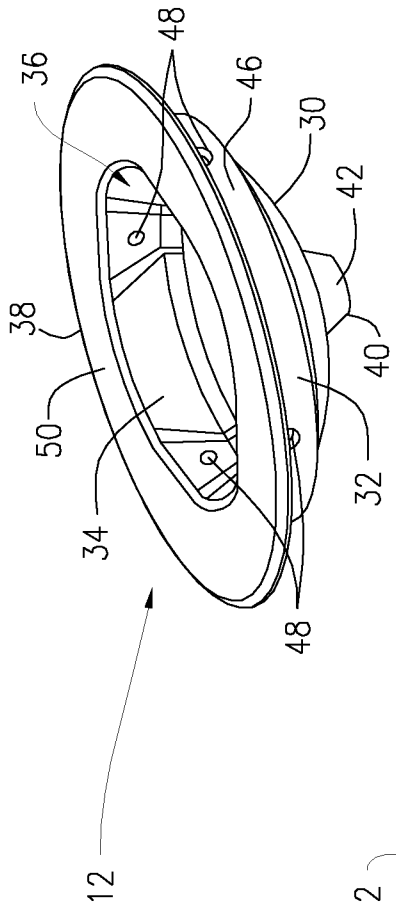

FIG. 4A

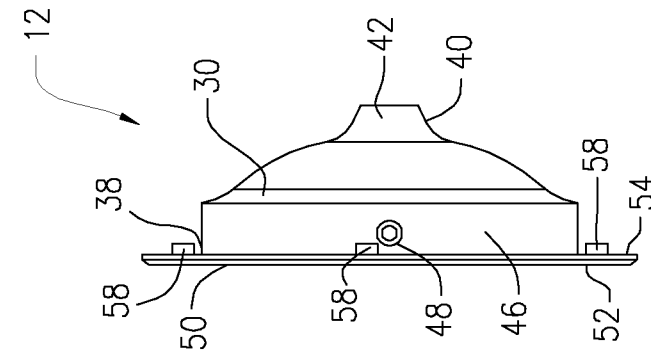

FIG. 4C

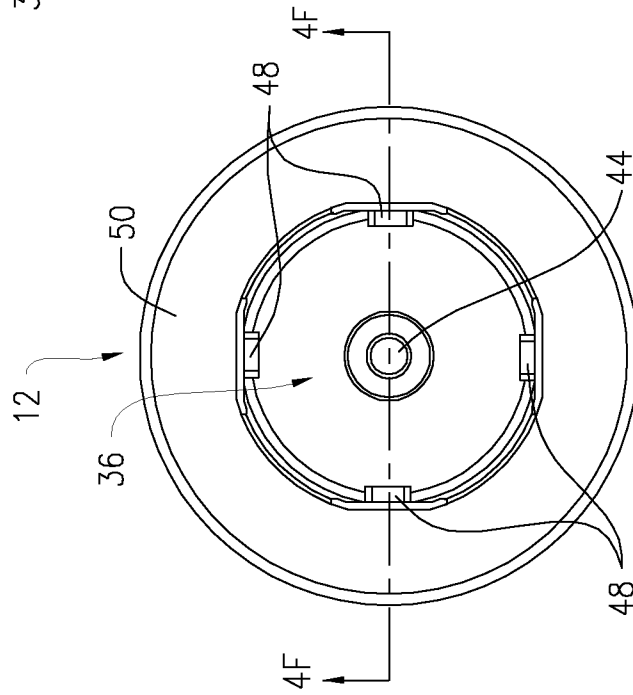

FIG. 4B

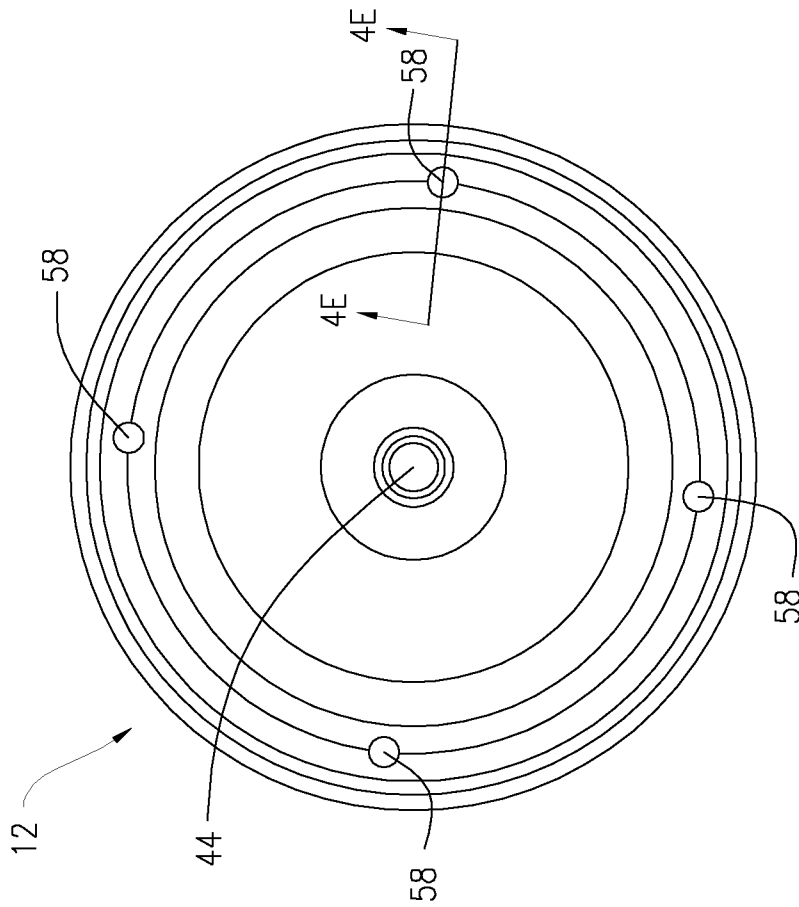

FIG. 4D



FIG. 4E

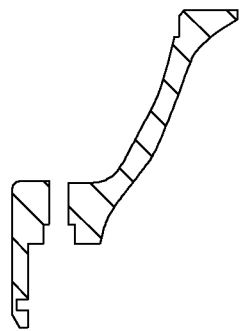

FIG. 4F

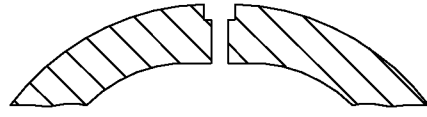
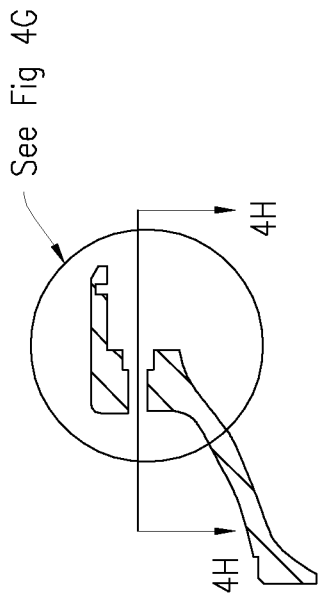

FIG. 4H

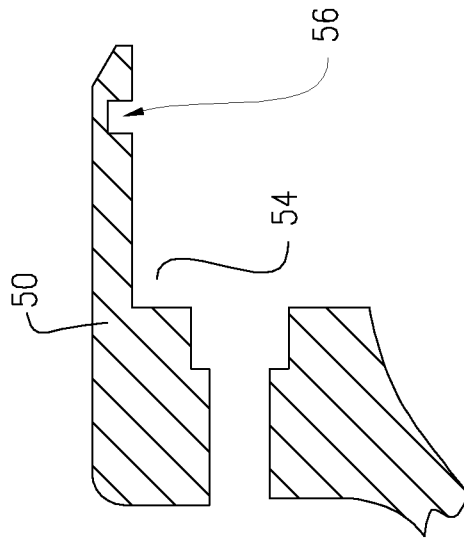

FIG. 4G

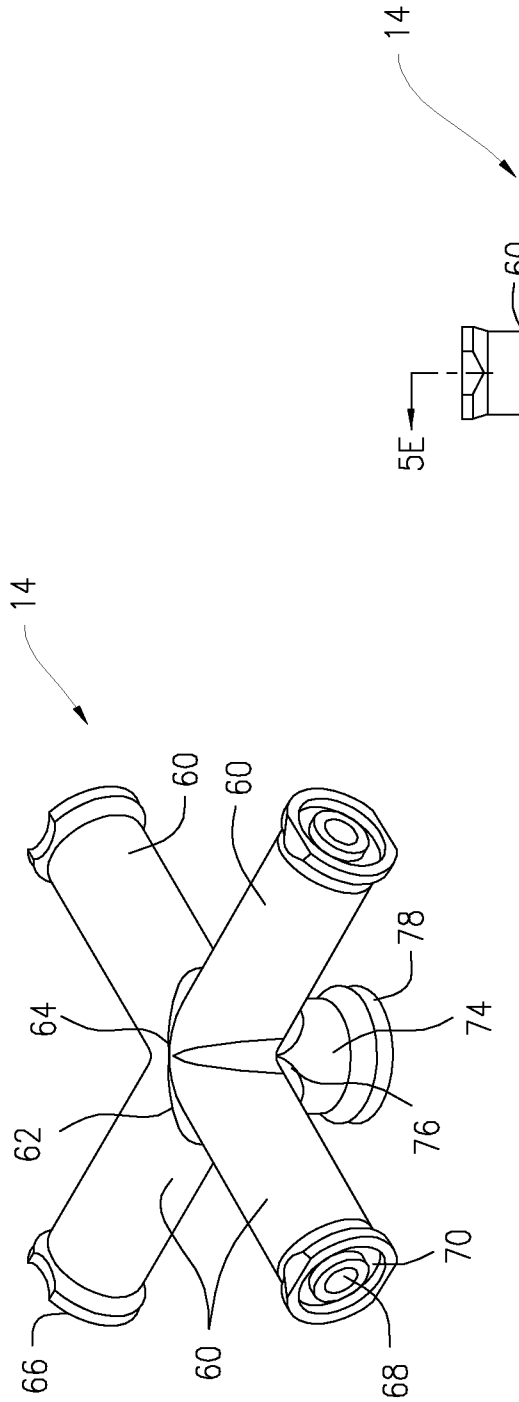

FIG. 5A

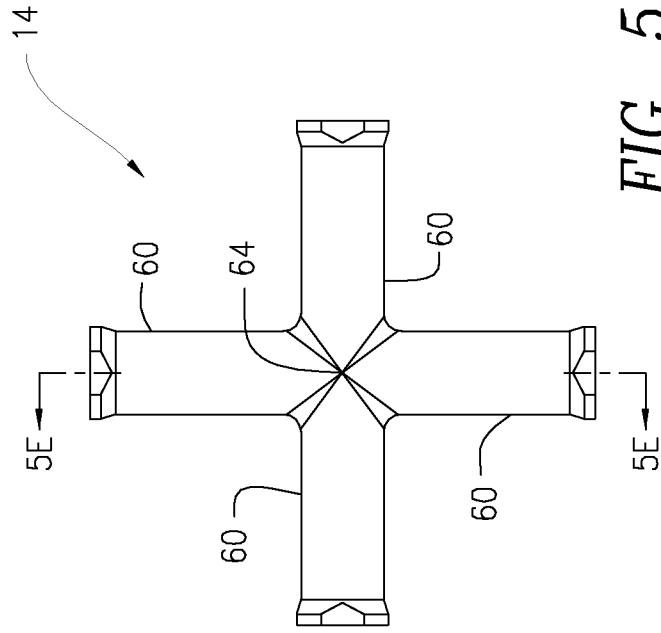

FIG. 5B

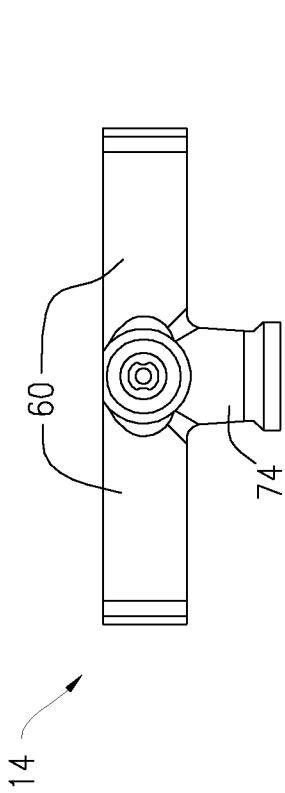

FIG. 5C

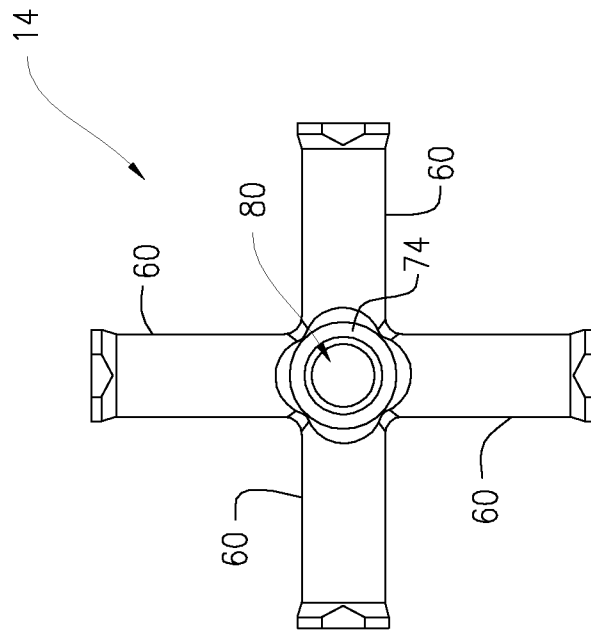

FIG. 5D

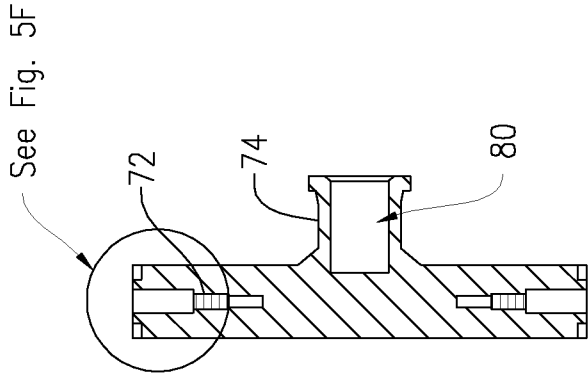

FIG. 5E

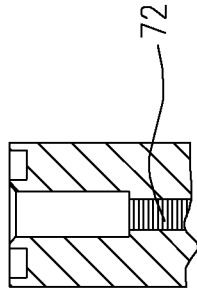

FIG. 5F

10/25

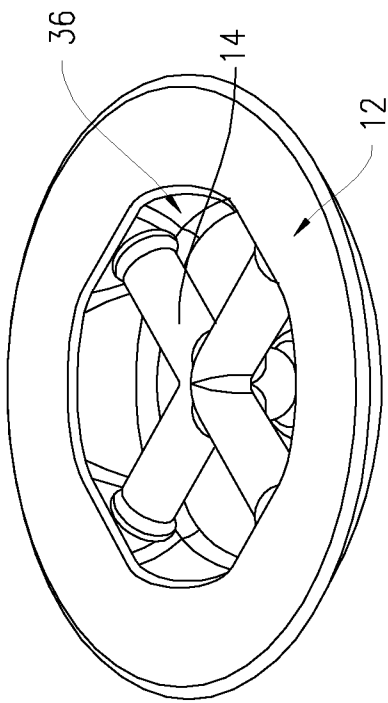

FIG. 6A

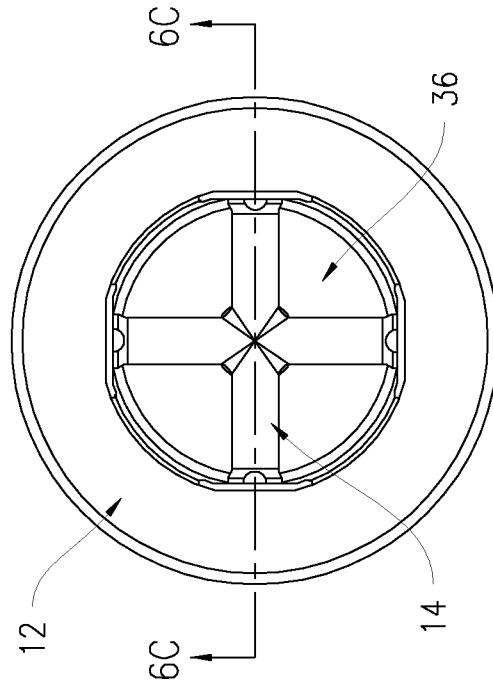

FIG. 6B

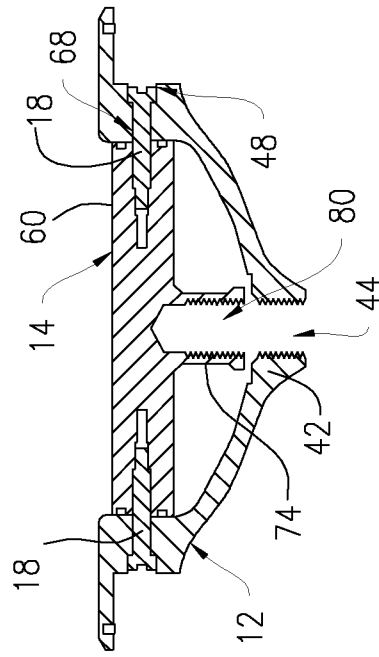

FIG. 6C

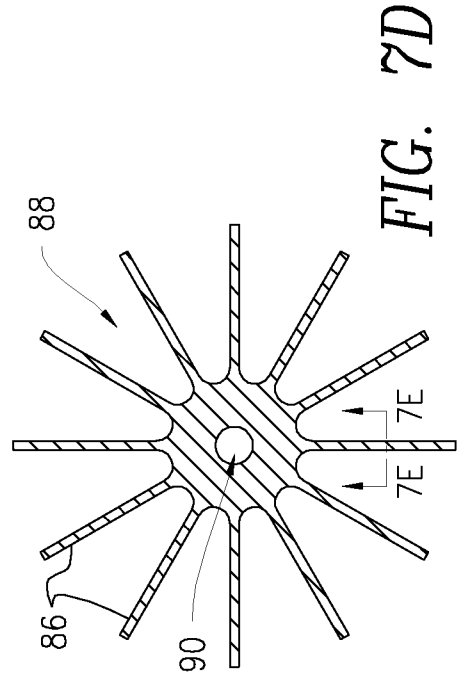
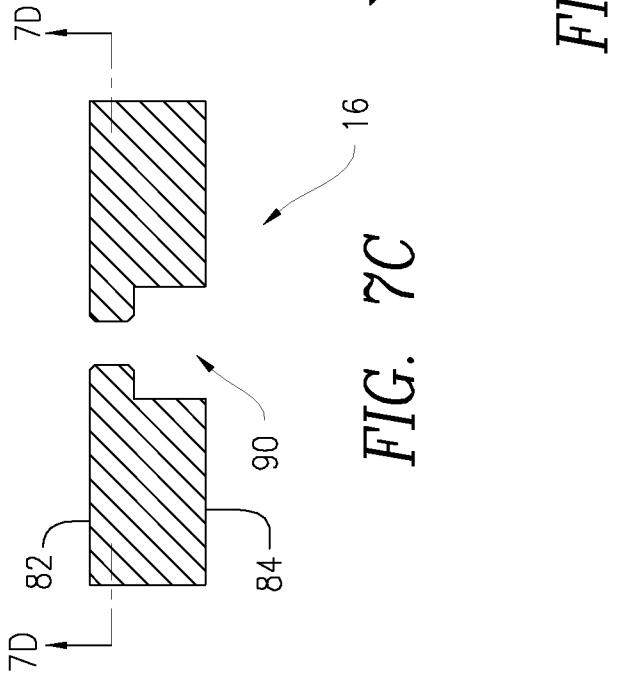
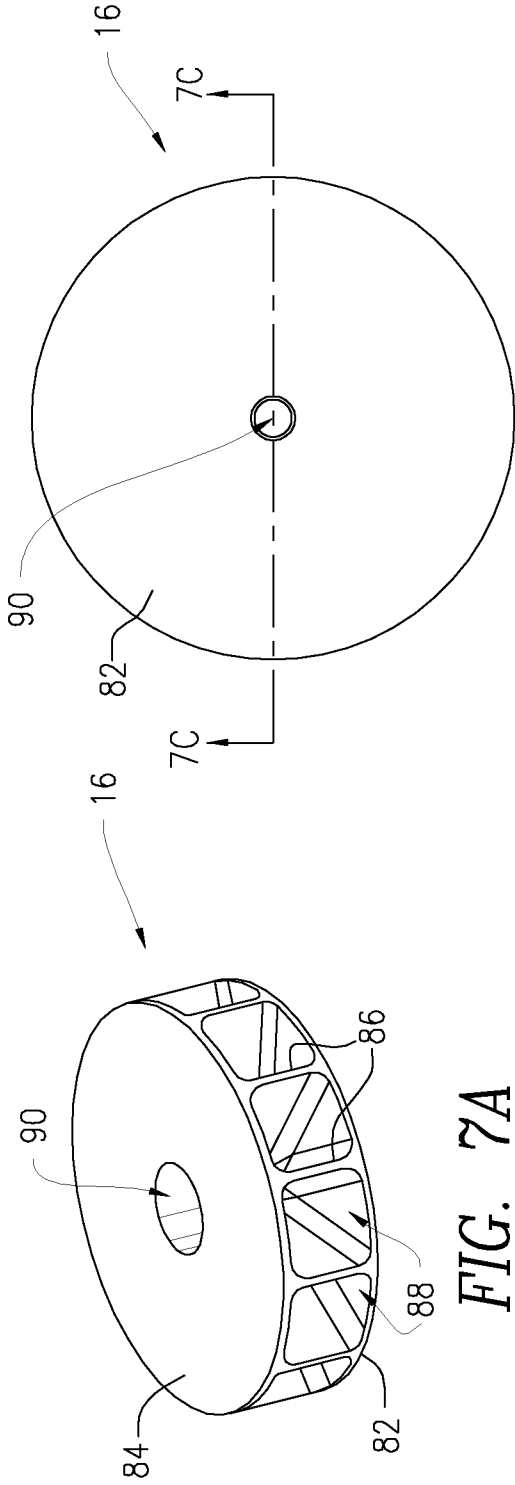

FIG. 7D

FIG. 7E

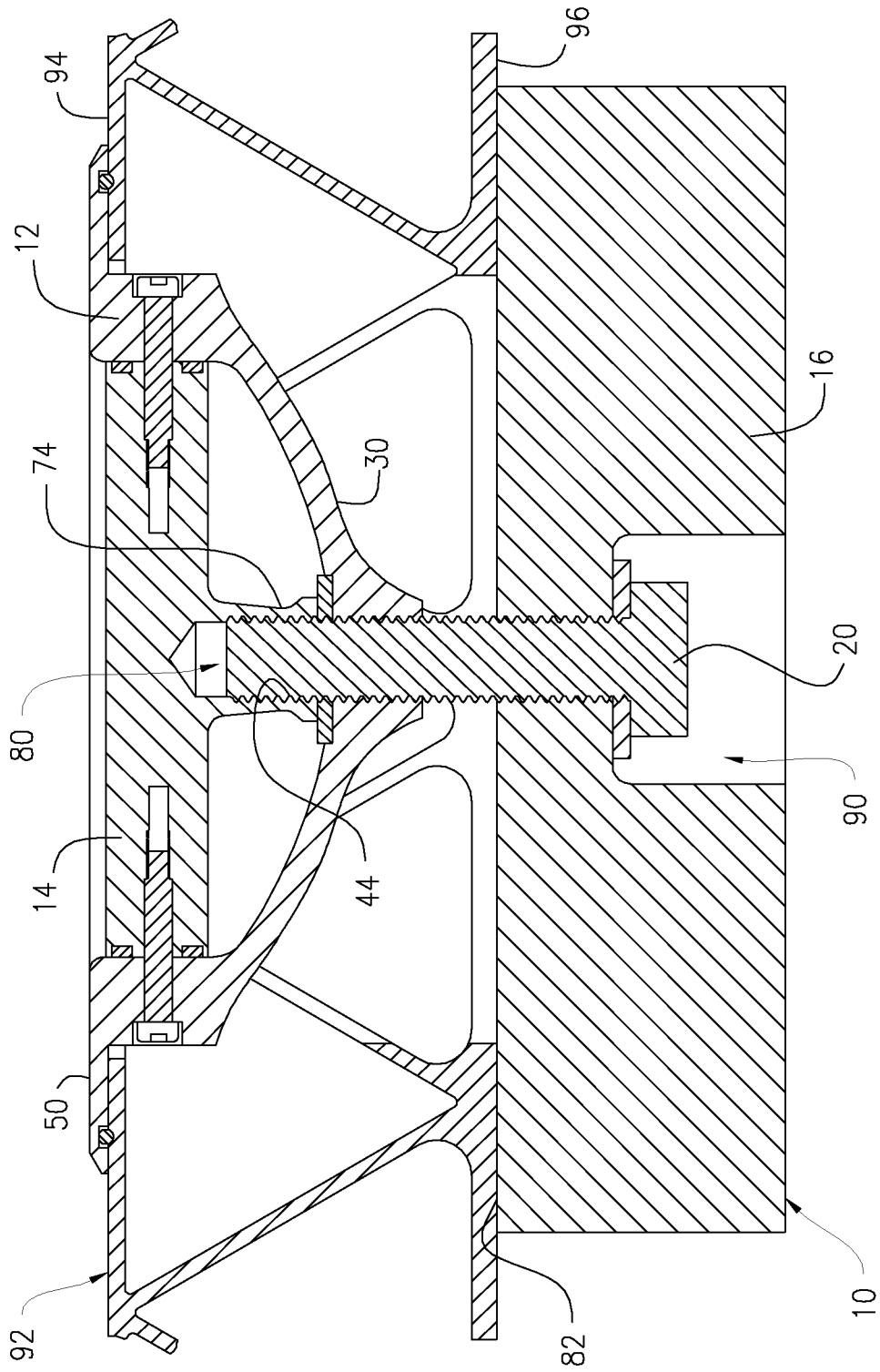

FIG. 8

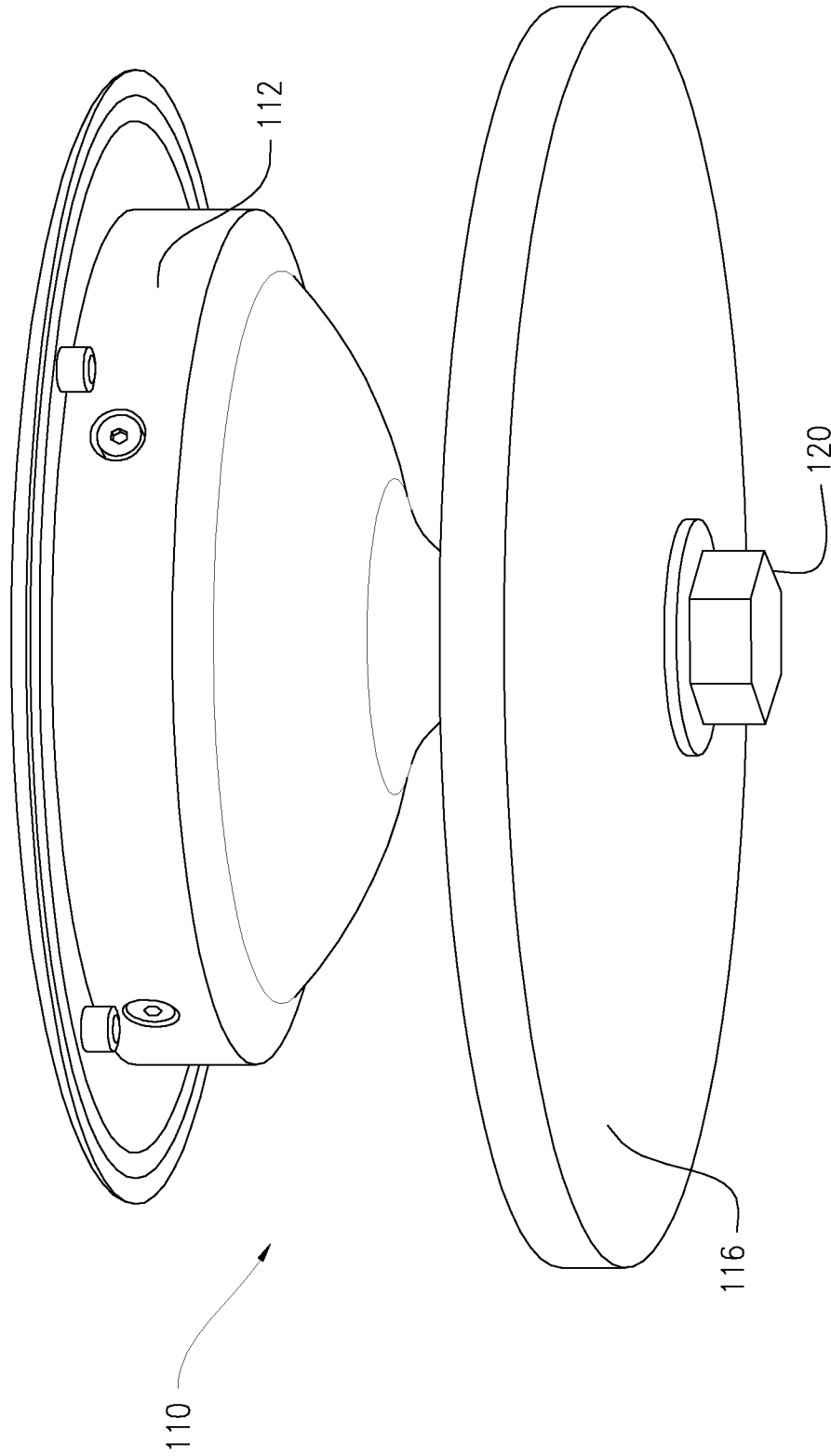

FIG. 9A

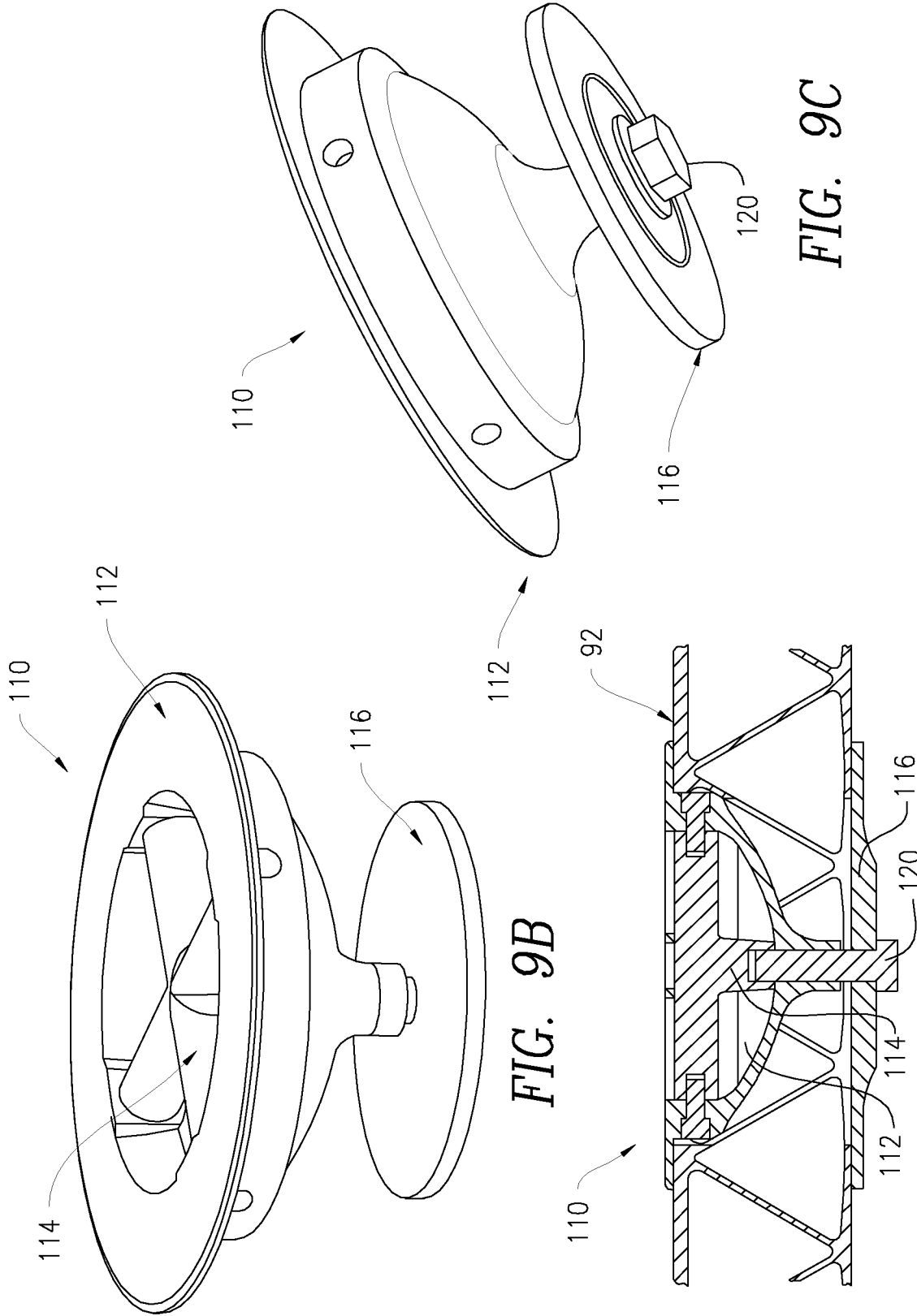

FIG. 9B

FIG. 9C

FIG. 9D

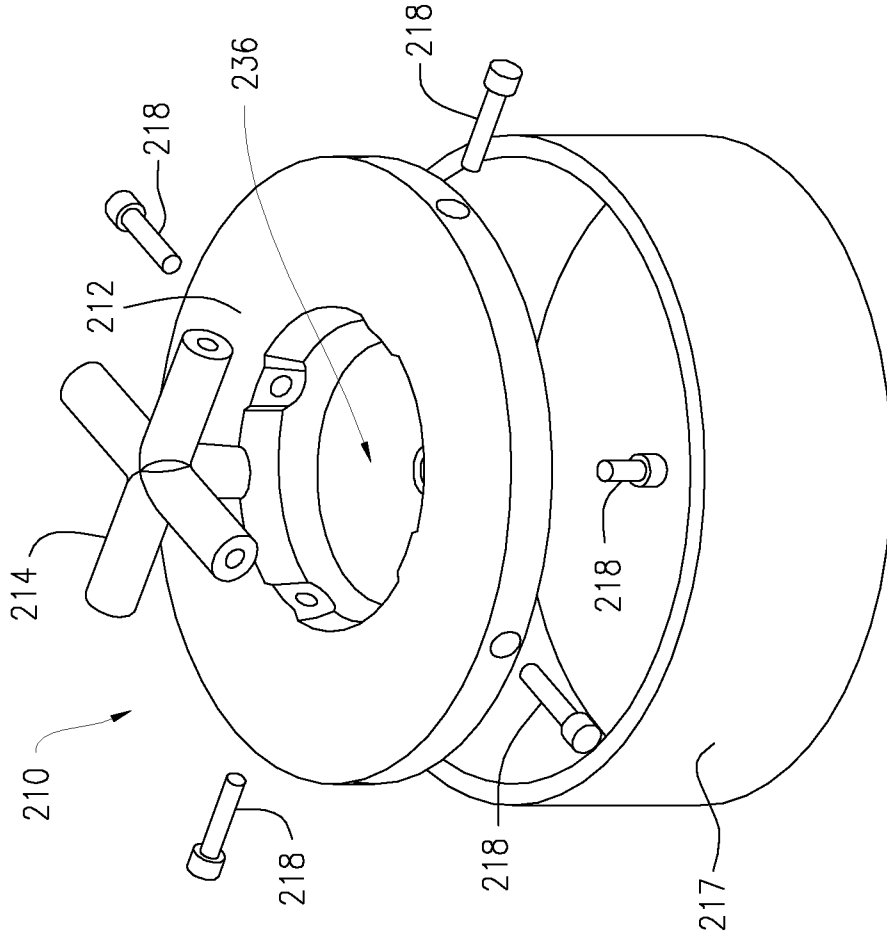

FIG. 10A

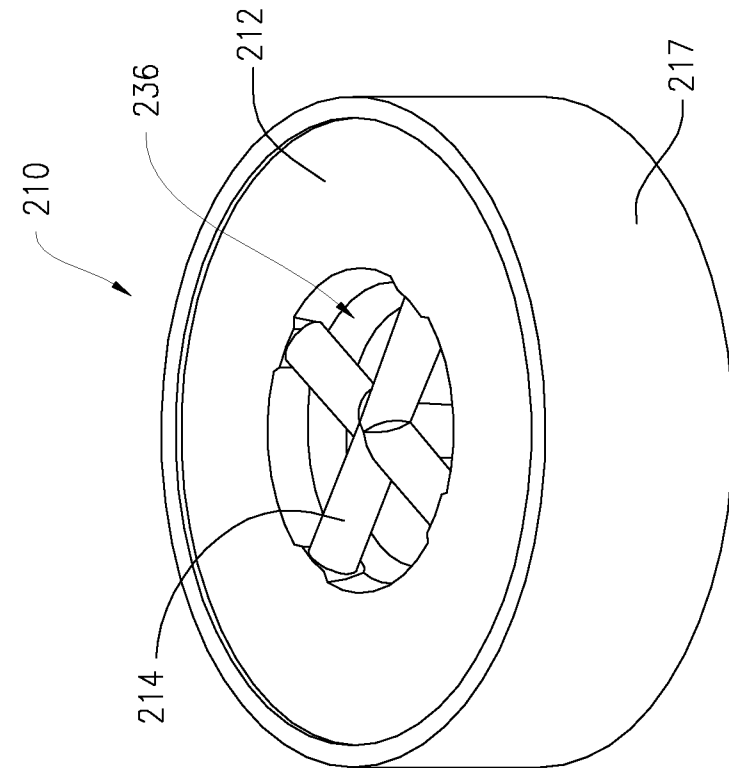

FIG. 10B

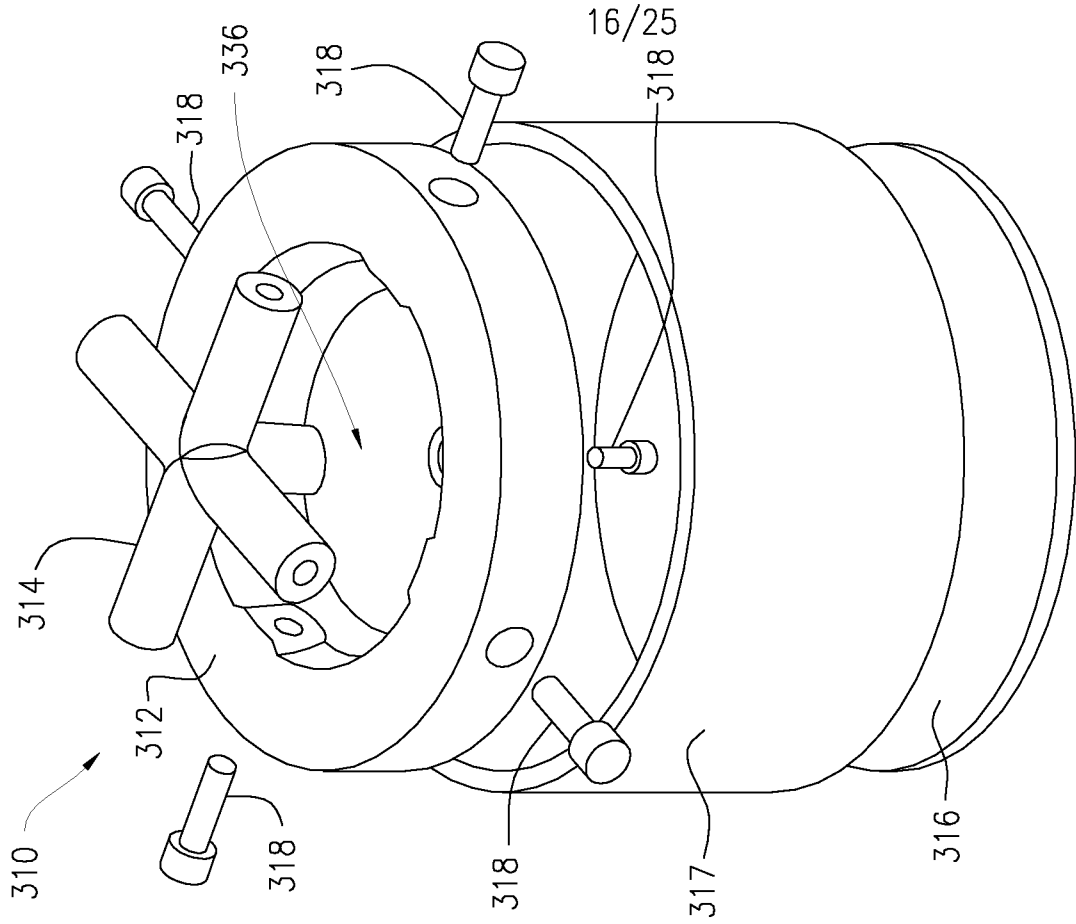

FIG. 11B

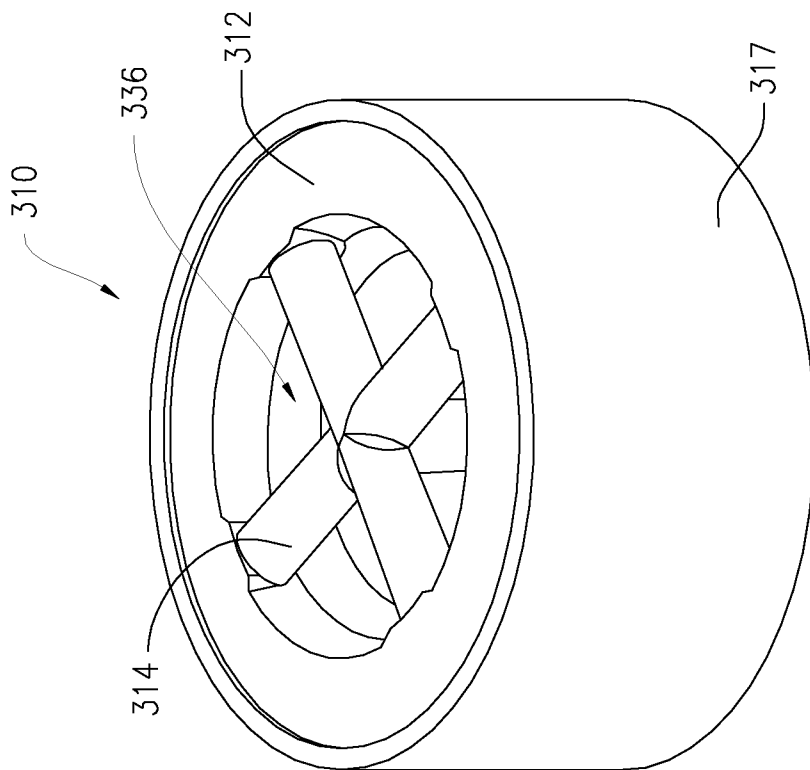

FIG. 11A

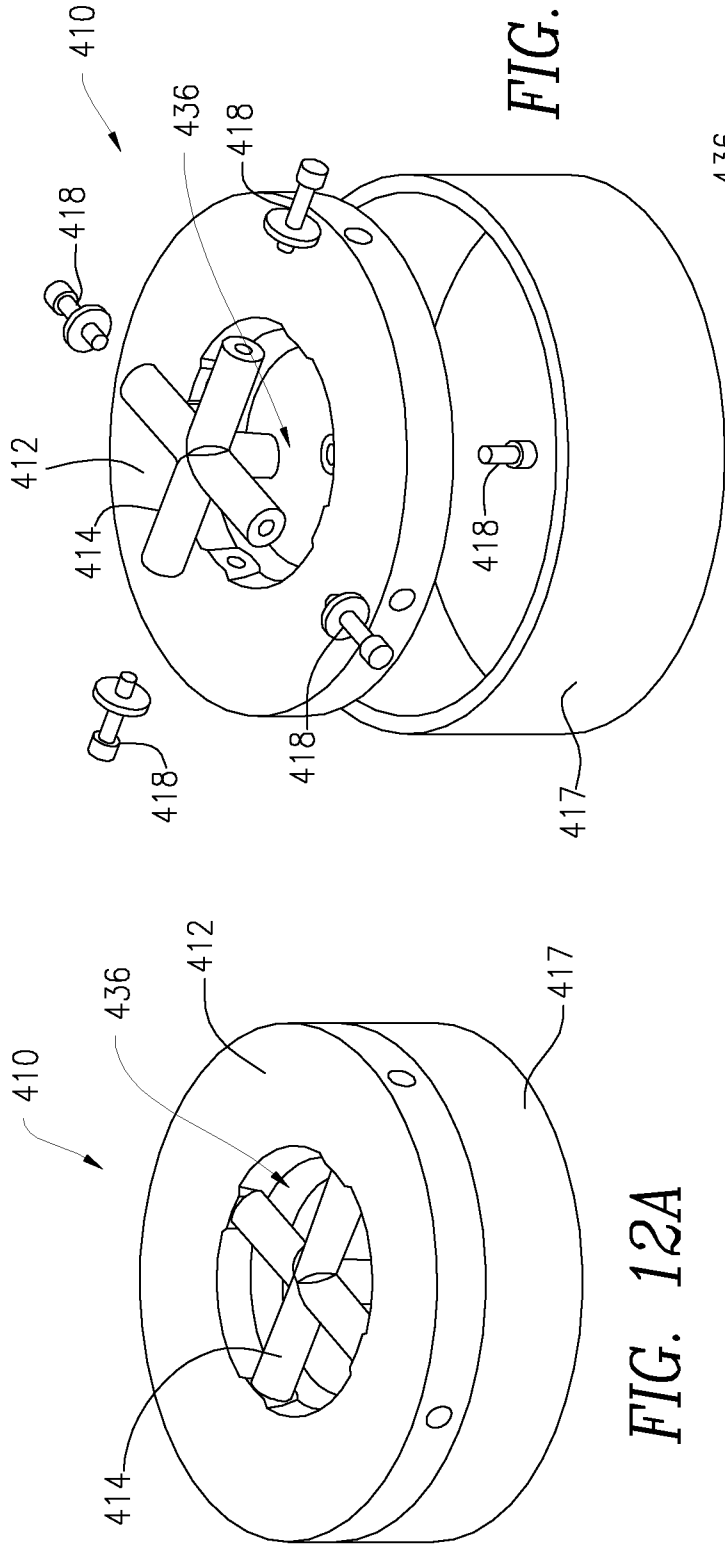

FIG. 12B

FIG. 12A

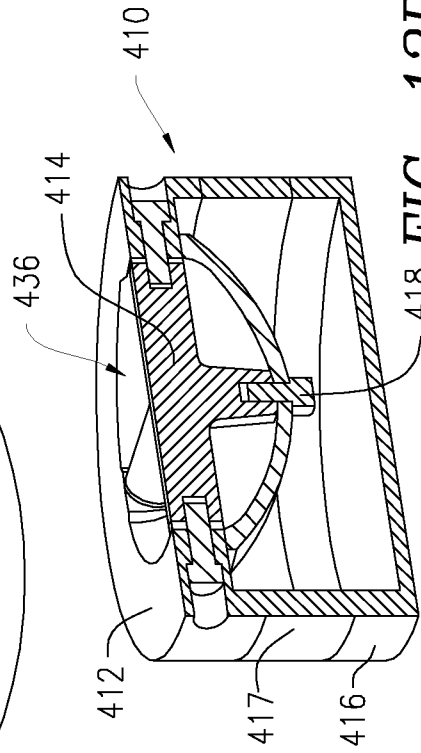

FIG. 12D

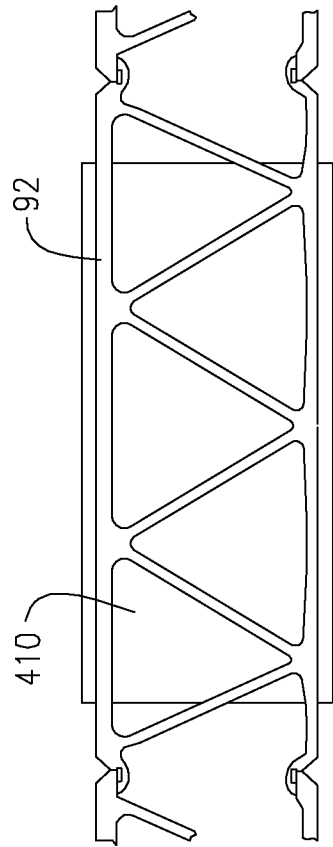

FIG. 12C

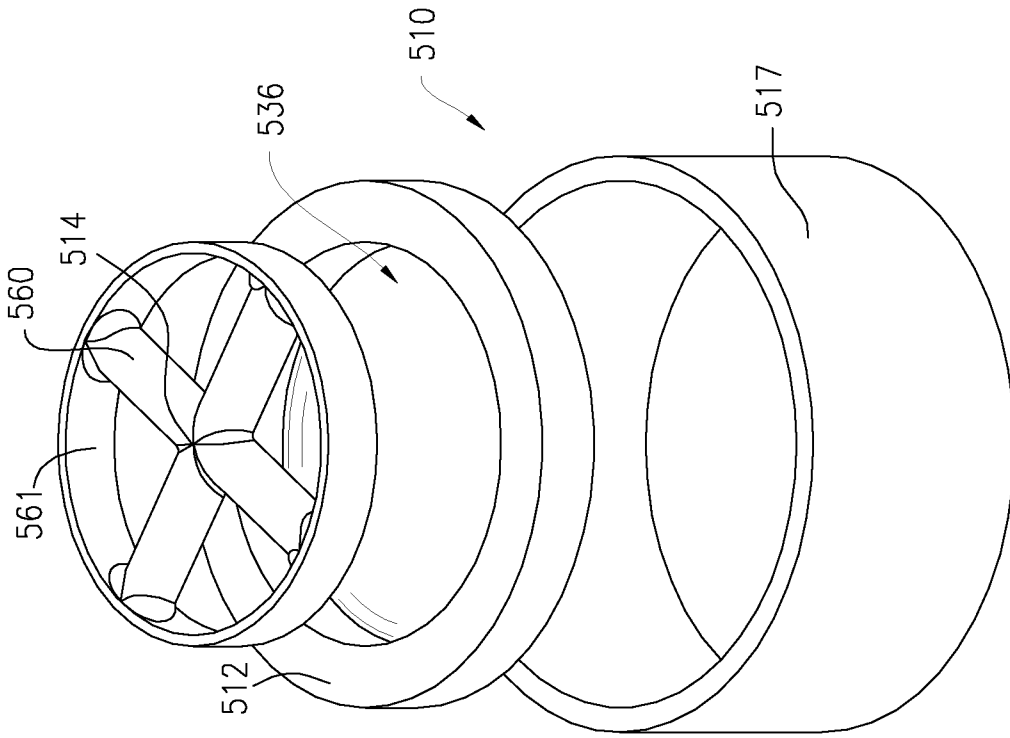

FIG. 13C

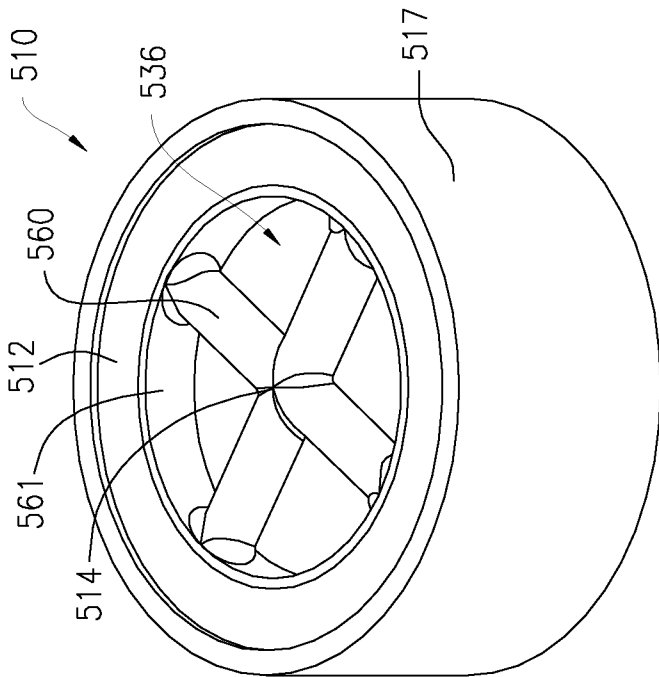

FIG. 13A

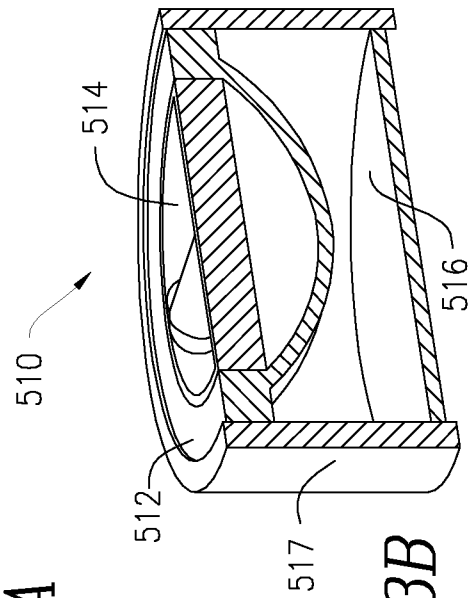
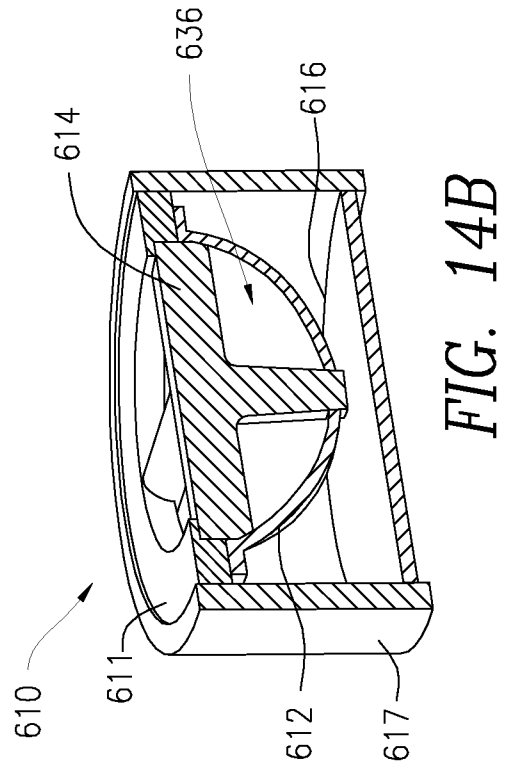
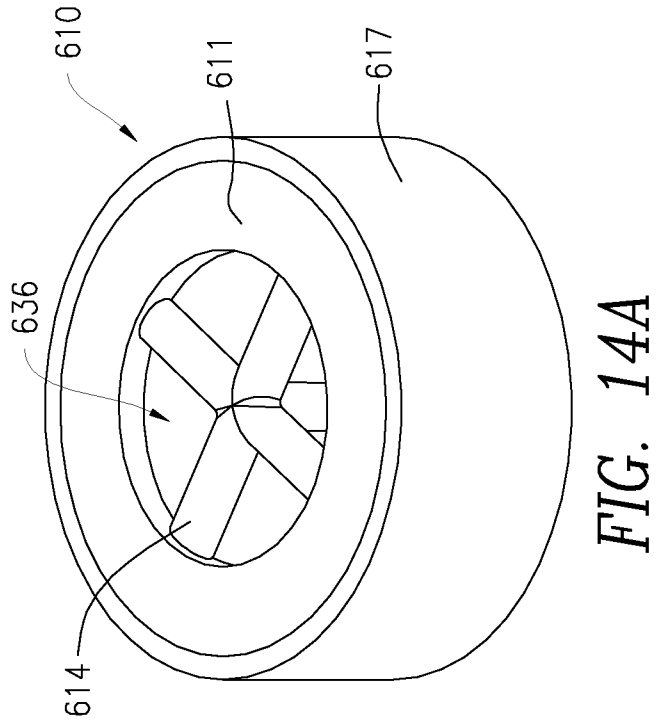
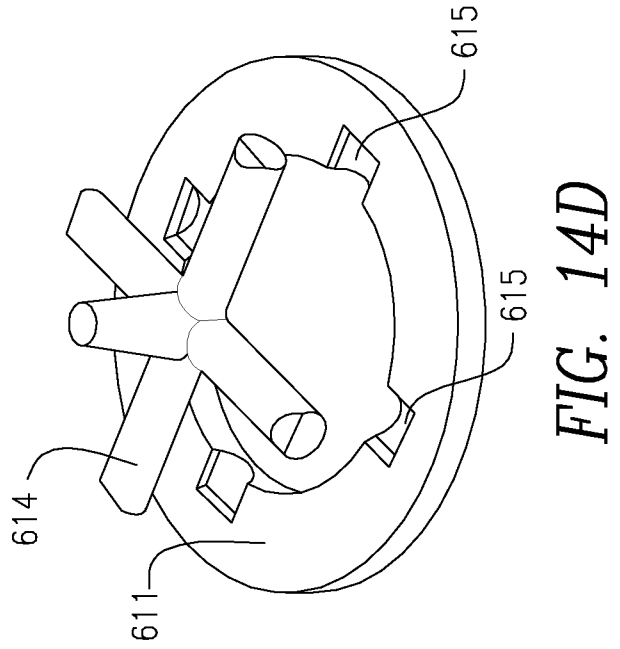
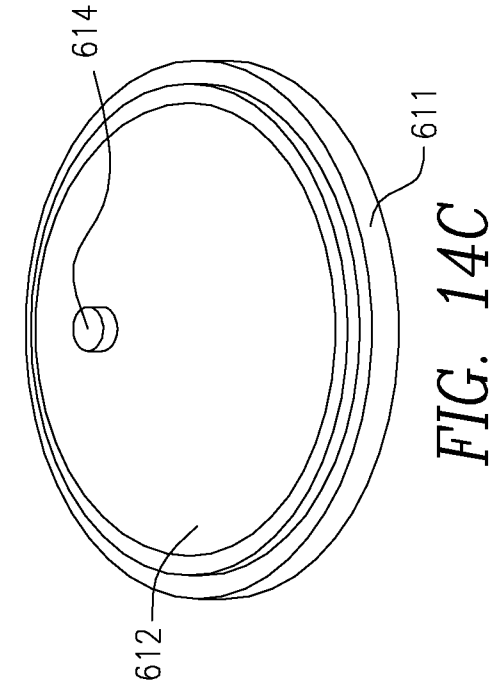

FIG. 13B



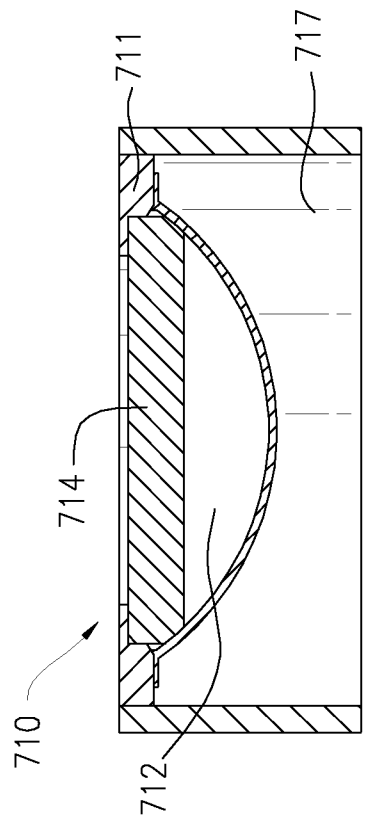
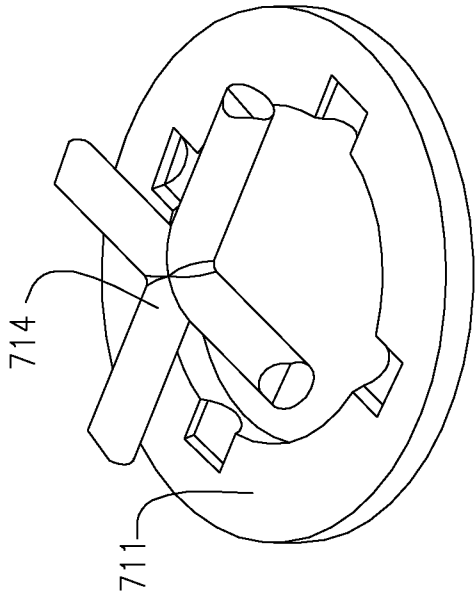
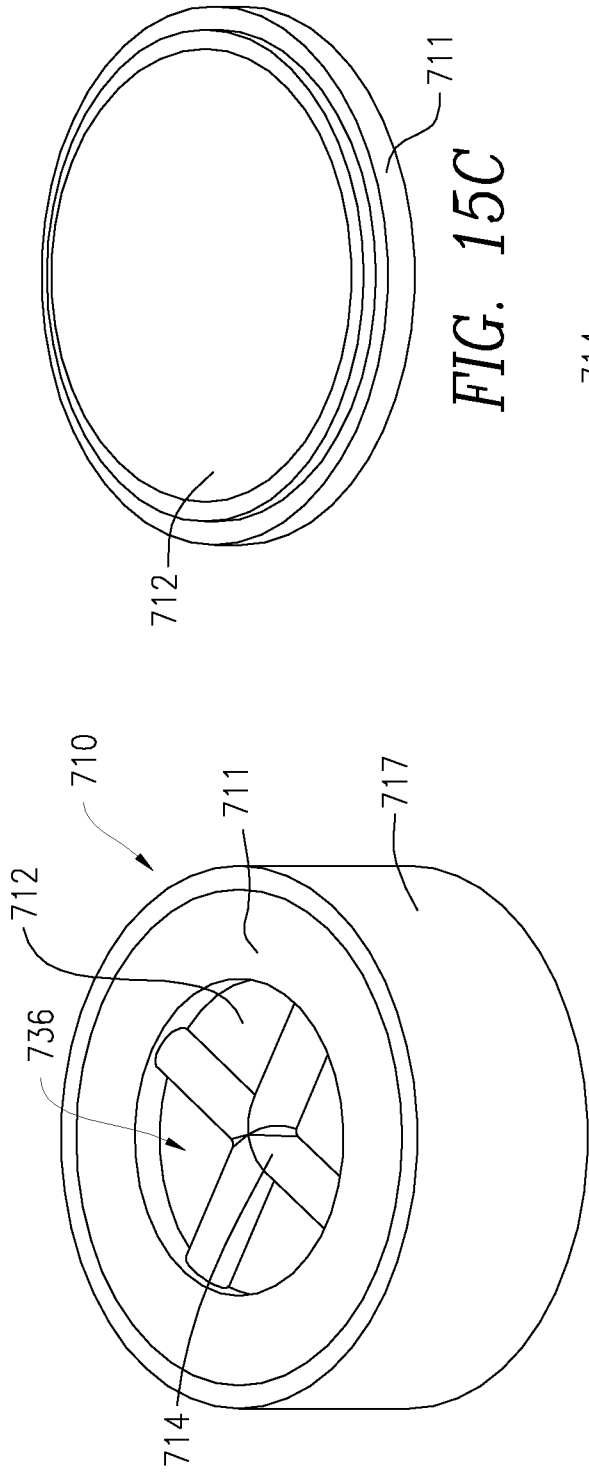

FIG. 15D

FIG. 15B

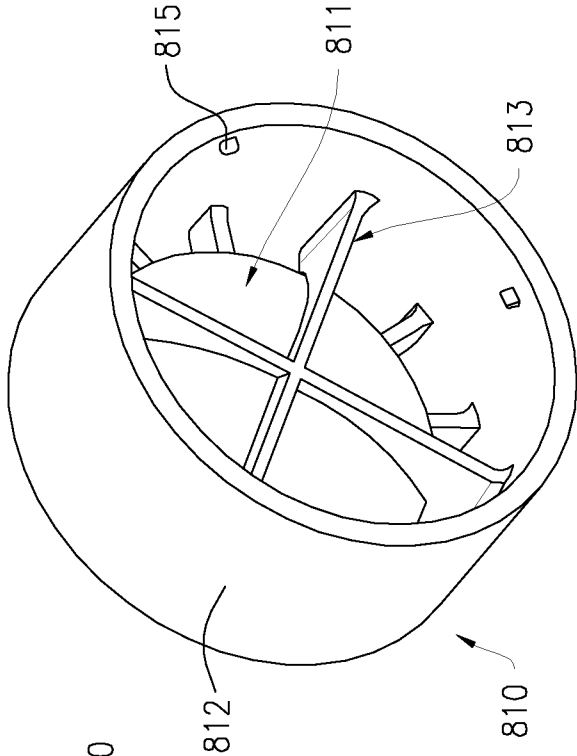

FIG. 16A

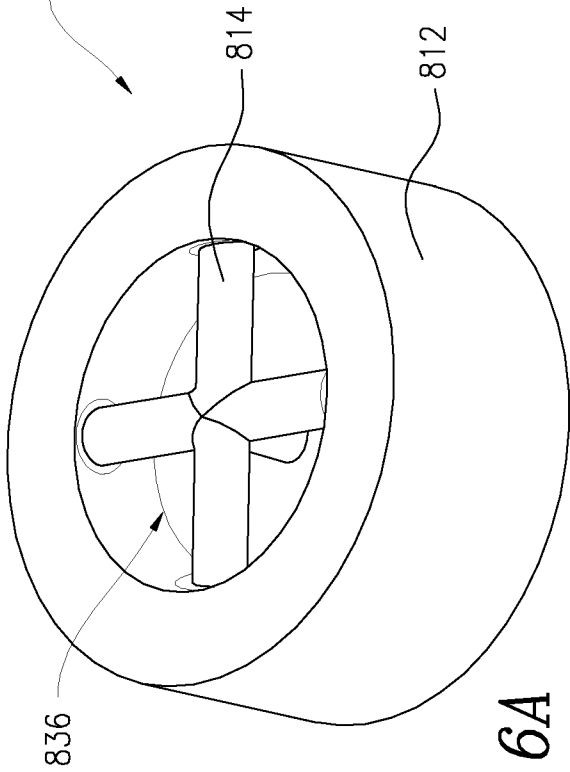

FIG. 16B

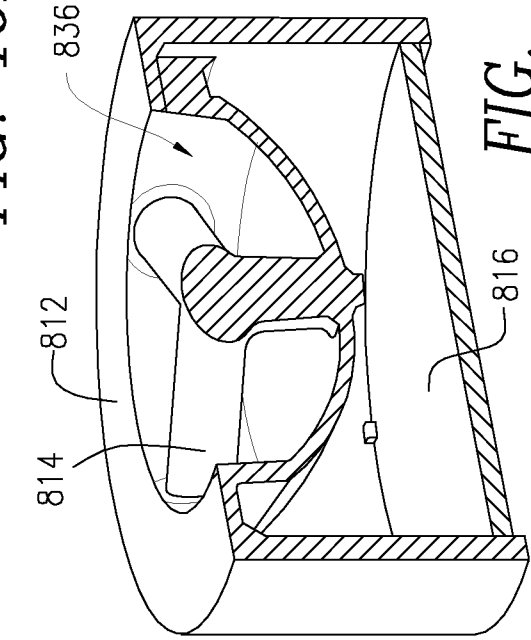

FIG. 16C

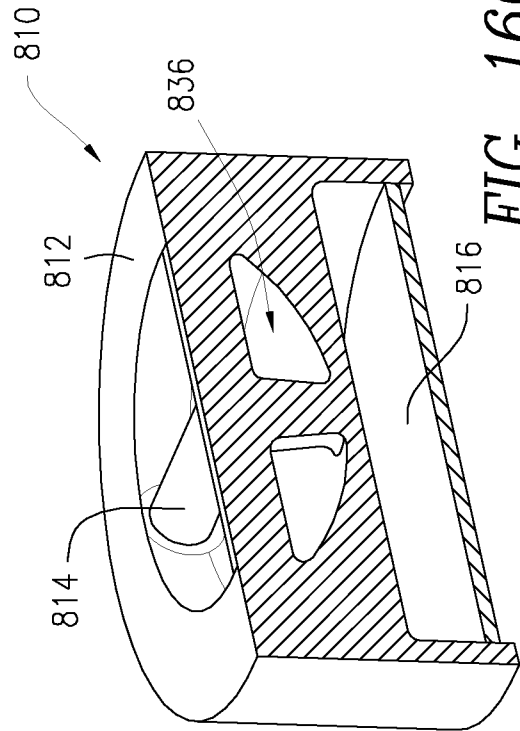
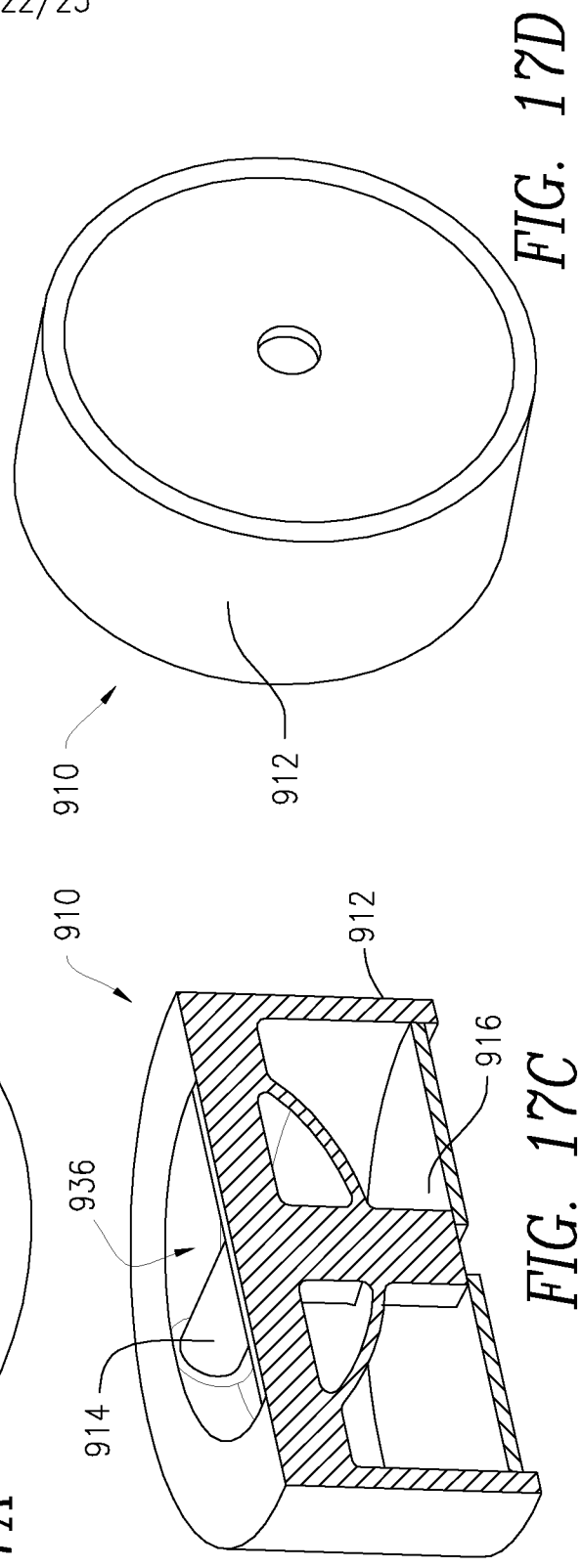
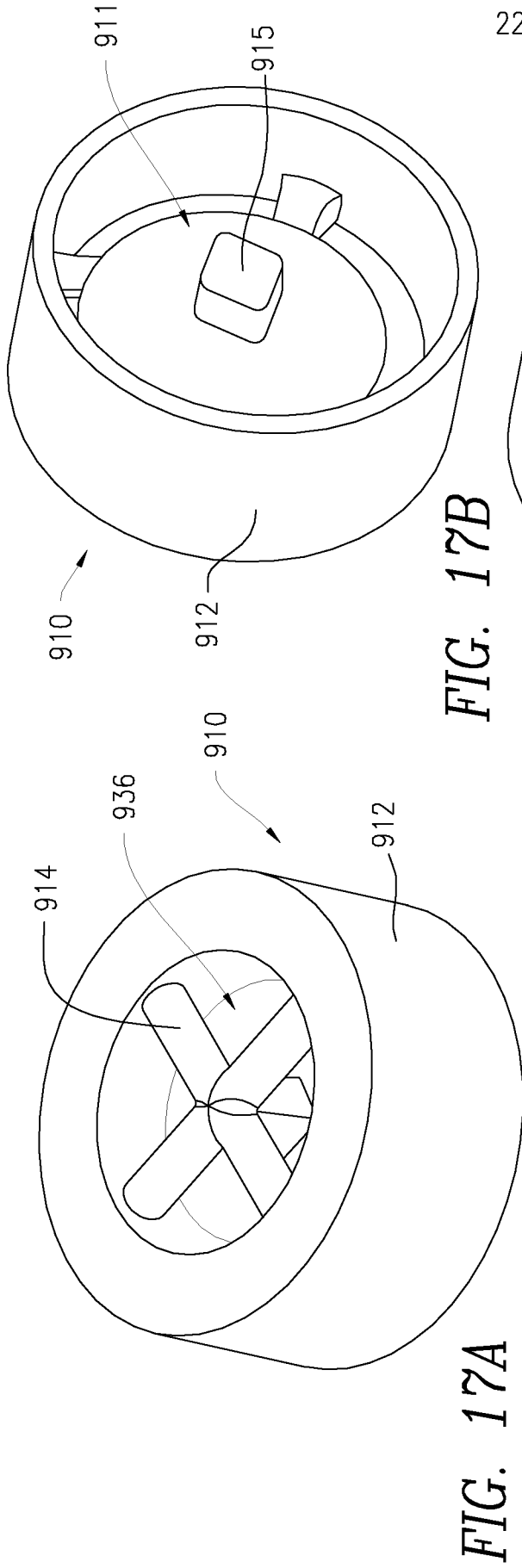

FIG. 16D



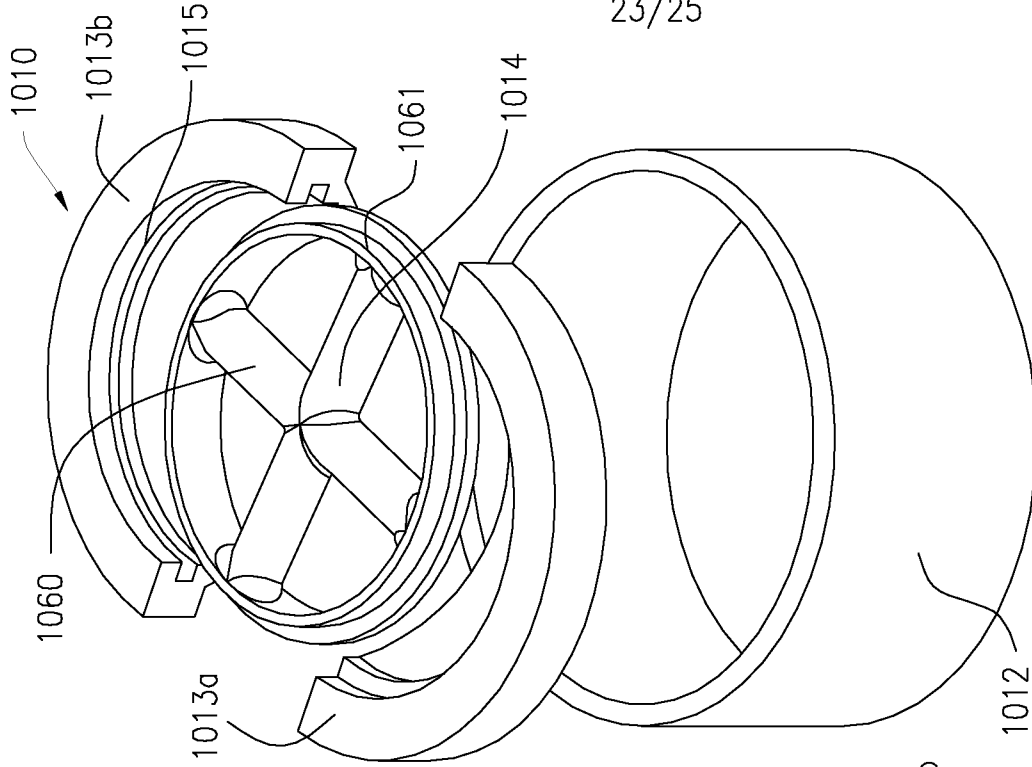

FIG. 18C

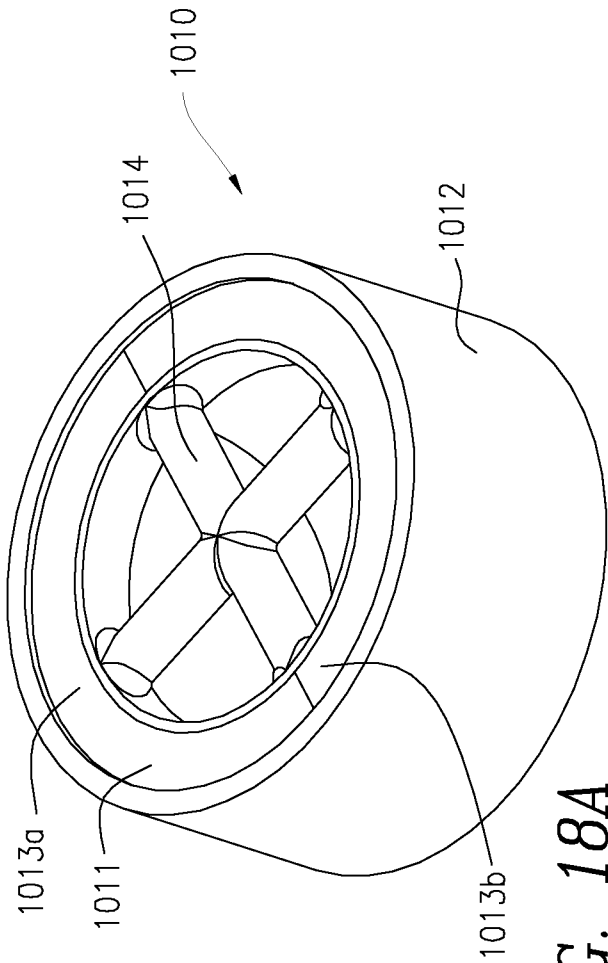

FIG. 18A

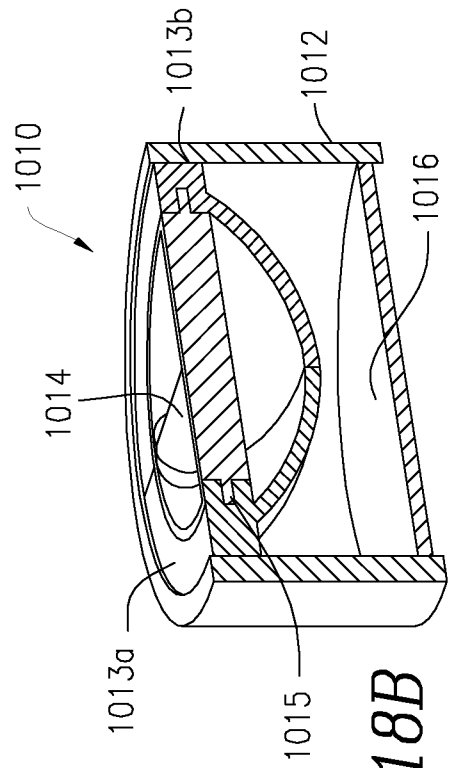

FIG. 18B

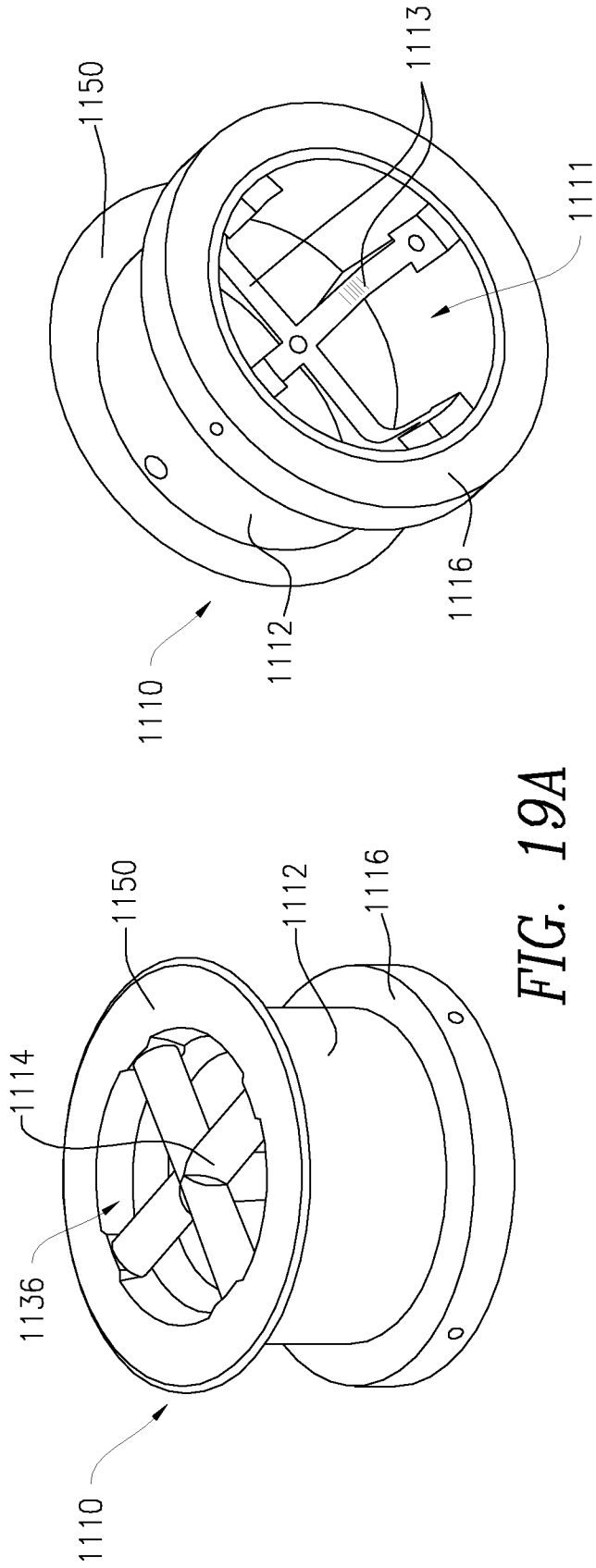

FIG. 19A

FIG. 19B

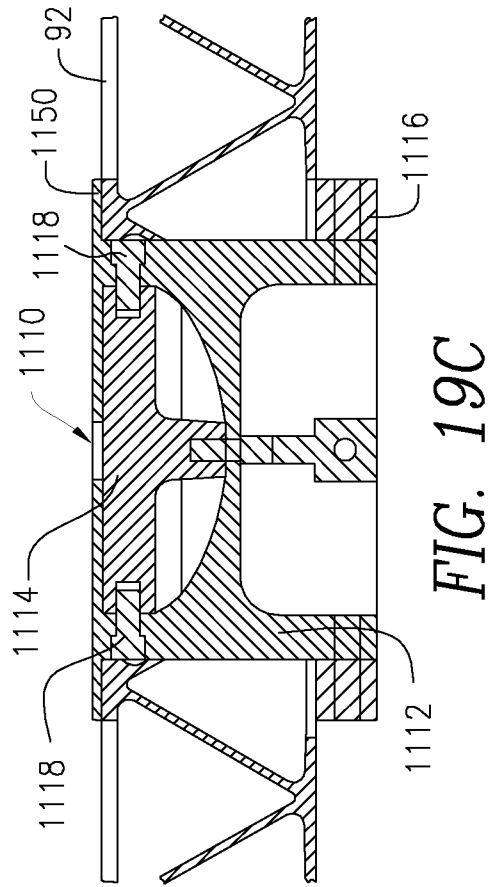

FIG. 19C

