



Europäisches Patentamt
European Patent Office
Office européen des brevets



(11) **EP 1 293 619 B1**

(12) **EUROPEAN PATENT SPECIFICATION**

(45) Date of publication and mention
of the grant of the patent:
09.02.2005 Bulletin 2005/06

(51) Int Cl.7: **E04C 3/11, E04B 1/24**

(21) Application number: **02394092.7**

(22) Date of filing: **12.09.2002**

(54) **Truss system and truss connector**

Trägerstruktur und Trägerverbindung

Structure en treillis et connecteur utilisé pour une telle structure

(84) Designated Contracting States:
**AT BE BG CH CY CZ DE DK EE ES FI FR GB GR
IE IT LI LU MC NL PT SE SK TR**

(30) Priority: **12.09.2001 EP 01650103**

(43) Date of publication of application:
19.03.2003 Bulletin 2003/12

(73) Proprietor: **WARD BUILDING COMPONENTS
LIMITED
Malton, North Yorkshire YO17 8PQ (GB)**

(72) Inventor: **Robertson, George Steven
Huntington, York YO3 9GN (GB)**

(74) Representative: **O'Brien, John Augustine et al
John A. O'Brien & Associates,
Third Floor,
Duncairn House,
14 Carysfort Avenue
Blackrock, Co Dublin (IE)**

(56) References cited:
**WO-A-01/14658 WO-A-96/22428
WO-A-98/40579**

EP 1 293 619 B1

Note: Within nine months from the publication of the mention of the grant of the European patent, any person may give notice to the European Patent Office of opposition to the European patent granted. Notice of opposition shall be filed in a written reasoned statement. It shall not be deemed to have been filed until the opposition fee has been paid. (Art. 99(1) European Patent Convention).

Description

[0001] The invention relates to truss systems and in particular to a truss system for use in converting a flat to a pitched roof.

[0002] More particularly, the invention relates to a truss system connector of the type comprising a sleeve portion to receive a structural member and a pair of arms extending from the sleeve portion. WO 01/14658 A describes a connector according to the preamble of claim 1.

[0003] Conventional truss systems comprise a large number of different components which are fitted together on site. The systems are time consuming to assemble and require considerable accuracy. Site cutting of the various components is required in order to cater for even minor tolerances and variations.

[0004] There is therefore a need for an improved truss system which will overcome these problems.

Statements of Invention

[0005] According to the invention there is provided a truss system connector comprising a sleeve portion to receive a structural member and a pair of arms extending from the sleeve portion to receive another structural member therebetween, said arms of the connector being cranked outwardly, characterised in that each of said arms has only one hole and said holes are aligned for receiving a pin.

[0006] Preferably the sleeve portion of the connector is of channel section comprising a bottom and a pair of upstanding sides, the arms extending from the sides of the channel section.

[0007] The invention also provides a truss system comprising a bottom boom, a rafter, at least one web member for extending between the boom and the rafter, and a truss connector of the invention. The sleeve of the truss connector receives a web member and the arms of the truss connector are pin jointed to the rafter or the bottom boom.

[0008] In one embodiment the truss system in addition comprises a second connector of the type comprising a sleeve portion to receive a structural member and a pair of arms extending from the sleeve wherein the arms of the second connector are co-planar with the sleeve portion.

[0009] The sleeve of second truss connector may receive a web member and the arms of the second connector are pin jointed to the rafter or the bottom boom.

[0010] Preferably the bottom boom and/or the rafter comprises a number of pre-drilled holes for receiving a pin for mounting a connector to a bottom boom or rafter.

[0011] In a preferred construction the bottom boom and/or rafter and/or web is a lipped channel.

[0012] In a particularly preferred embodiment the bottom boom and the rafter are of the same section.

[0013] Ideally the bottom boom, the rafter and the web

member are of the same section.

Brief Description of Drawings

5 **[0014]** The invention will be more clearly understood from the following description thereof given by way of example only, in which: -

10 Fig 1 is a perspective view of portion of a roof support structure incorporating a truss system of the invention;

15 Fig 2 is a perspective view of portion of the assembled truss system of the invention;

20 Fig 3 is a cross sectional view of portion of the assembled truss system;

25 Fig 4 is perspective view of a straight knuckle connector of the truss system;

30 Fig 5 is an elevational view of the connector of Fig 4;

35 Fig 6 is a perspective view of a cranked knuckle connector of the truss system;

40 Fig 7 is an elevational view of the connector of Fig 6;

45 Fig 8 is a perspective view of a truss beam of the truss system;

50 Fig 9 is a view of an apex detail of the truss system;

55 Fig 10 is a view of an eaves detail of a truss system with parapet fixing;

Fig 11 is a view of an eaves detail of a truss system with roof fixing; and

Fig 12 is a view of another eaves detail of the truss system with soffit and fascia support details included.

[0015] The connector of Fig. 4 and 5 can be a part of the truss system of the invention as defined in claims 3 to 11. The connector of Fig. 4 and 5 as such does however not fall within the scope of the connector of the invention as defined in claims 1 and 2.

Detailed Description

50 **[0016]** Referring to the drawings there is illustrated a truss system comprising bottom booms 1, rafters 2, and a plurality of web members 3 extending between the bottom booms 1 and the rafters 2. Connectors 5 are used for pin jointing between the web members 3, the rafters 2 and the bottom booms 1.

55 **[0017]** Each of the rafters 2, bottom booms 1 and web members 3 are in this case of the same lipped channel

section 10 (Fig. 8) of cold rolled steel. The arms 11 of the channel section 10 are pre-drilled with a number of spaced apart holes 12, the holes 12 in the opposite arms 11 of the channel being aligned to receive a mounting pin 13. Because the rafters, bottom booms and web members are of the same section the truss system is greatly simplified as the number of different elements is minimised.

[0018] The system comprises two different connectors, namely a straight knuckle connector 5a (Figs 4 and 5) and a cranked knuckle connector 5b (Figs 6 and 7). In each case the connector comprises a sleeve portion 20 to telescopically receive a section 10 such as a web member 3 and at least one arm extending from the sleeve portion 20 for pin jointing, for example to a bottom boom 1 or a rafter 2. The sleeve portion 20 has lipped channel cross section for receiving the lipped channel section of the web member 3. For secure mounting, preferably there are two arms 21, 22 extending from the sides of the sleeve portion 20 and the arms 21, 22 are spaced-apart to defined a gap therebetween.

[0019] In the case of the straight knuckle connector 5a the arms 21, 22 are co-planner with the sleeve portion 20 and the gap between the arms 21, 22 is approximately the same as or slightly greater than the width of the channel section 10 so that the arms 21, 22 embrace the channel section 10 and are securely pin jointed to it. In the case of the cranked knuckle connector 5b according to the invention the arms 21, 22 are cranked outwardly at 23 so that the gap defined between them is wider than the gap between the arms of the connector 5a to embrace not only a channel section 10 but also to receive the arms of a connector 5a therebetween, on assembly as illustrated particularly in Fig. 2.

[0020] The arms 21, 22 of both connectors 5a, 5b have pre-drilled holes 25 adjacent the free ends thereof for alignment, on assembly, with the holes 12 of the channel section 10. A pin 13 in the form of a bolt is passed through the holes in the connectors 5a, 5b and the channel section 10 which is used for the bottom booms 1, rafters 2 and web members 3.

[0021] The system can be used for any desired angle of web 3 between a bottom boom 1 and a rafter 2. The connectors 5a and/or 5b form a pin joint at the attachment between a web member 3 and a bottom boom 1 or a rafter 2 as will be particularly apparent from Fig 2. A typical roof structure built up from the truss system of the invention is illustrated in Fig 1. Even with such a relatively simple structure the variations in the web angles will be apparent. Using the truss system of the invention a wide variation in web angles can be catered for using the same components.

[0022] Various roof details that are formed using the truss system of the invention are illustrated in Figs 9 to 12.

[0023] Fig 9 illustrates an apex detail in which connectors 5 are used to pin joint rafters 2 at the apex. A top tie 30 extends between the rafters 2 and the ends

of the adjacent web members 3 as extended by the connectors 5.

[0024] Fig 10 illustrates an eaves detail for parapet fixing in which a bottom boom 1 is secured directly to an existing roof for conversion of a flat roof to a pitched roof.

[0025] An eaves detail for a roof fixing is illustrated in Fig. 11. A holding down cleat 35 is stitched to the side of the bottom boom 1.

[0026] An eaves detail including soffit and fascia supports is illustrated in Fig 12. A bottom boom 1 is attached to an eaves beam 40 using a connector 45. The connector 45 has a sleeve 46 to receive the bottom boom 1 and outturned arms 47, 48 which are bolted to the eaves beam. A clear 49 is also provided.

[0027] The pin jointed truss system of the invention is lightweight and provides a cost effective flat to pitched roof conversion system particularly in clear span (un-supported) applications of up to 12 metres or for larger spans in which support can be provided by the existing roof. The truss system is versatile and can be used in conjunction with any suitable cladding system. The components of the truss system are pre-fabricated and standardised for quick and simple assembly. The components are lightweight and can be readily assembled on a roof or on the ground and easily handled into position is avoided for clear span systems. Disruption to a building or its occupants.

[0028] The invention is not limited to the embodiments hereinbefore described which may be varied in detail within the scope of the set of claims.

Claims

1. A truss system connector (5b) comprising a sleeve portion (20) to receive a structural member (1, 2, 3) and a pair of arms (21, 22) extending from the sleeve portion (20) to receive another structural member therebetween, said arms (21, 22) of the connector being cranked outwardly **characterised in that** each of said arms (21, 22) has only one hole (25) and said holes (25) are aligned for receiving a pin (13).
2. A connector as claimed in claim 1 wherein the sleeve portion (20) of the connector (5b) is of a channel section comprising a bottom and a pair of upstanding sides, the arms (21, 22) extending from the sides of the channel section.
3. A truss system comprising a bottom boom (1), a rafter (2), at least one web member (3) for extending between the boom (1) and the rafter (2), and a truss connector (5b) according to claim 1 or 2, wherein the sleeve (20) of the truss connector (5b) receives a web member (3) and the arms (21, 22) of the truss connector (5b) are pin jointed to the rafter (2) or the bottom boom (1).

4. A truss system as claimed in claim 3 comprising a second connector 5(a) of the type comprising a sleeve portion (20) to receive a structural member (1, 2, 3) and a pair of arms (21, 22) extending from the sleeve wherein the arms (21, 22) of the second connector (5(a)) are co-planar with the sleeve portion.
5. A truss system as claimed in claim 4 wherein the sleeve (20) of the second truss connector (5(a)) receives a web member (3) and the arms (21, 22) of the second connector (5(a)) are pin jointed to the rafter (2) or the bottom boom (1).
6. A truss system as claimed in any of claims 3 to 5 wherein the bottom boom (1) and/or the rafter (2) comprises a number of pre-drilled holes (12) for receiving the pin (13) for mounting a connector (5, 5a, 5b) to a bottom boom (1) or rafter (2).
7. A truss system as claimed in any of claims 3 to 6 wherein the bottom boom (1) is a lipped channel.
8. A truss system as claimed in any of claims 3 to 7 wherein the rafter (2) is a lipped channel.
9. A truss system as claimed in any of claims 3 to 8 wherein the web member (3) is a lipped channel.
10. A truss system as claimed in any of claims 3 to 9 wherein the bottom boom (1) and the rafter (2) are of the same section.
11. A truss system as claimed in any of claims 3 to 10 wherein the bottom boom (1), the rafter (2) and the web member (3) are of the same section.

Patentansprüche

1. Fachwerkssystemverbinder (5b), der einen Hülse-
teil (20) zum Aufnehmen eines Konstruktionsele-
ments (1, 2, 3) und ein Paar von Armen (21, 22) auf-
weist, die sich von dem Hülse-
teil (20) zum Aufnehmen eines andere Konstruktionselements zwi-
schen denselben erstrecken; wobei die genannten
Arme (21, 22) des Verbinders nach außen verkröpft
sind, **dadurch gekennzeichnet, dass** jeder der ge-
nannten Arme (21, 22) nur ein Loch (25) aufweist
und die genannten Löcher (25) zum Aufnehmen eines
Bolzens (13) ausgerichtet sind.
2. Verbinder nach Anspruch 1, bei dem der Hülse-
teil (20) des Verbinders (5b) einen Kanalschnitt auf-
weist, der einen Boden und ein Paar hochstehender
Seiten aufweist, wobei die Arme (21, 22) sich von
den Seiten des Kanalschnitts erstrecken.

3. Fachwerkssystem, das einen Untergurt (1), einen
Sparren (2), mindestens ein Stegelement (3), das
zwischen dem Gurt (1) und dem Sparren (2) verlau-
fen soll, und einen Fachwerkverbinder (5b) gemäß
Anspruch 1 oder 2 aufweist, wobei die Hülse (20)
des Fachwerkverbinders (5b) ein Stegelement (3)
aufnimmt und die Arme (21, 22) des Fachwerkver-
binders (5b) durch Bolzen mit dem Sparren (2) oder
dem Untergurt (1) verbunden werden.
4. Fachwerkssystem nach Anspruch 3, das einen zwei-
ten Verbinder (5(a)) des Typs aufweist, der einen
Hülse-
teil (20) zum Aufnehmen eines Konstrukti-
onselements (1, 2, 3) und ein Paar von Armen (21,
22) umfasst, die sich von der Hülse erstrecken, wo-
bei die Arme (21, 22) des zweiten Verbinders (5(a))
koplanar mit dem Hülse-
teil sind.
5. Fachwerkssystem nach Anspruch 4, bei dem die
Hülse (20) des zweiten Fachwerkverbinders (5(a))
ein Stegelement (3) aufnimmt, und die Arme (21,
22) des zweiten Verbinders (5(a)) durch Bolzen mit
dem Sparren (2) oder dem Untergurt (1) verbunden
werden.
6. Fachwerkssystem nach einem der Ansprüche 3 bis
5, bei dem der Untergurt (1) und/oder der Sparren
(2) eine Anzahl vorgebohrter Löcher (12) zum Auf-
nehmen des Bolzens (13) aufweist, um einen Ver-
binder (5, 5a, 5b) an einem Untergurt (1) oder Spar-
ren (2) anzubringen.
7. Fachwerkssystem nach einem der Ansprüche 3 bis
6, bei dem der Untergurt (1) ein mit einem Rand ver-
sehener Kanal ist.
8. Fachwerkssystem nach einem der Ansprüche 3 bis
7, bei dem der Sparren (2) ein mit einem Rand ver-
sehener Kanal ist.
9. Fachwerkssystem nach einem der Ansprüche 3 bis
8, bei dem das Stegelement (3) ein mit einem Rand
versehener Kanal ist.
10. Fachwerkssystem nach einem der Ansprüche 3 bis
9, bei dem der Untergurt (1) und der Sparren (2)
den gleichen Schnitt aufweisen.
11. Fachwerkssystem nach einem der Ansprüche 3 bis
10, bei dem der Untergurt (1), der Sparren (2) und
das Stegelement (3) den gleichen Schnitt aufwei-
sen.

Revendications

1. Connecteur de système de ferme (5b) comprenant
une portion manchon (20) pour recevoir une pièce

- de charpente (1, 2, 3) et une paire de bras (21, 22) s'étendant depuis la portion manchon (20) pour recevoir une autre pièce de charpente entre eux, lesdits bras (21, 22) du connecteur étant coudés vers l'extérieur, **caractérisé en ce que** chacun desdits bras (21, 22) n'a qu'un seul trou (25) et que lesdits trous (25) sont alignés pour recevoir une cheville (13).
2. Connecteur tel que revendiqué dans la revendication 1, dans lequel la portion manchon (20) du connecteur (5b) est d'une section en U comprenant un fond et une paire de côtés verticaux, les bras (21, 22) s'étendant depuis les côtés de la section en U.
3. Système de ferme comprenant une membrure inférieure (1), un chevron (2), au moins une membrure d'âme (3) pour s'étendre entre la membrure (1) et le chevron (2), et un connecteur de ferme (5b) selon la revendication 1 ou 2, dans lequel le manchon (20) du connecteur de ferme (5b) reçoit une membrure d'âme (3) et les bras (21, 22) du connecteur de ferme (5b) sont articulés au chevron (2) ou à la membrure inférieure (1).
4. Système de ferme tel que revendiqué dans la revendication 3 comprenant un deuxième connecteur (5(a)) du type comprenant une portion manchon (20) pour recevoir une pièce de charpente (1, 2, 3) et une paire de bras (21, 22) s'étendant depuis le manchon, dans lequel les bras (21, 22) du deuxième connecteur (5(a)) sont coplanaires avec la portion manchon.
5. Système de ferme tel que revendiqué dans la revendication 4, dans lequel le manchon (20) du deuxième connecteur de ferme (5(a)) reçoit une membrure d'âme (3) et les bras (21, 22) du deuxième connecteur (5(a)) sont articulés au chevron (2) ou à la membrure inférieure (1).
6. Système de ferme tel que revendiqué dans l'une quelconque des revendications 3 à 5, dans lequel la membrure inférieure (1) et/ou le chevron (2) comportent un certain nombre de trous pré-perçés (12) pour recevoir la cheville (13) pour monter un connecteur (5, 5a, 5b) sur une membrure inférieure (1) ou un chevron (2).
7. Système de ferme tel que revendiqué dans l'une quelconque des revendications 3 à 6, dans lequel la membrure inférieure (1) est un profilé en U à rebords.
8. Système de ferme tel que revendiqué dans l'une quelconque des revendications 3 à 7, dans lequel le chevron (2) est un profilé en U à rebords.
9. Système de ferme tel que revendiqué dans l'une quelconque des revendications 3 à 8, dans lequel la membrure d'âme (3) est un profilé en U à rebords.
10. Système de ferme tel que revendiqué dans l'une quelconque des revendications 3 à 9, dans lequel la membrure inférieure (1) et le chevron (2) sont de la même section.
11. Système de ferme tel que revendiqué dans l'une quelconque des revendications 3 à 10, dans lequel la membrure inférieure (1), le chevron (2) et la membrure d'âme (3) sont de la même section.

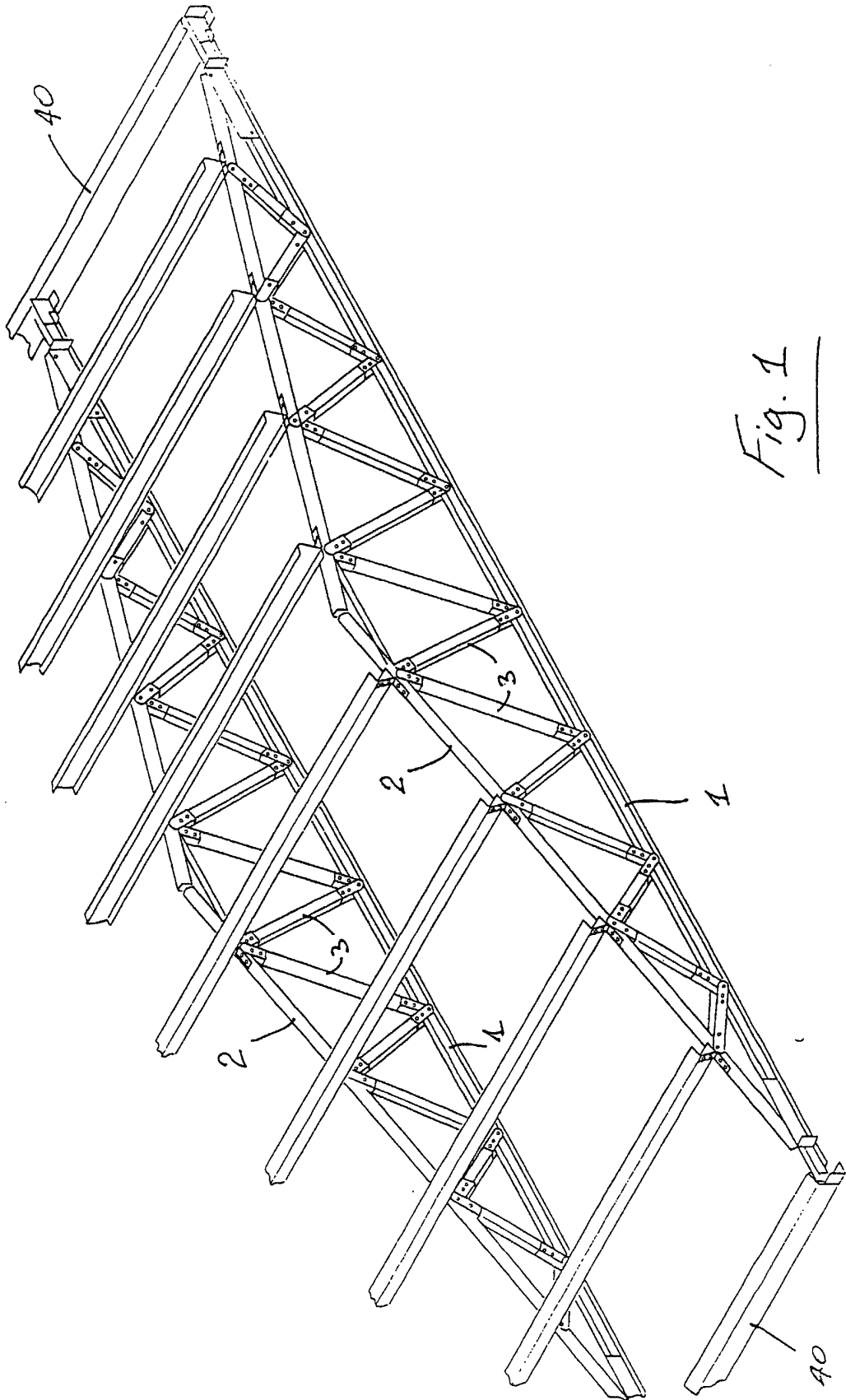

Fig. 1

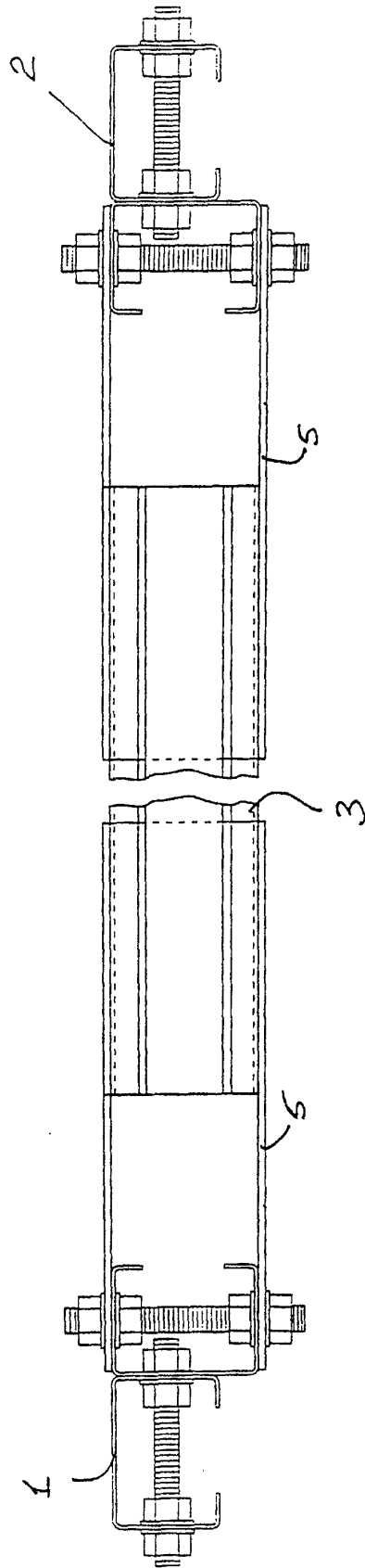
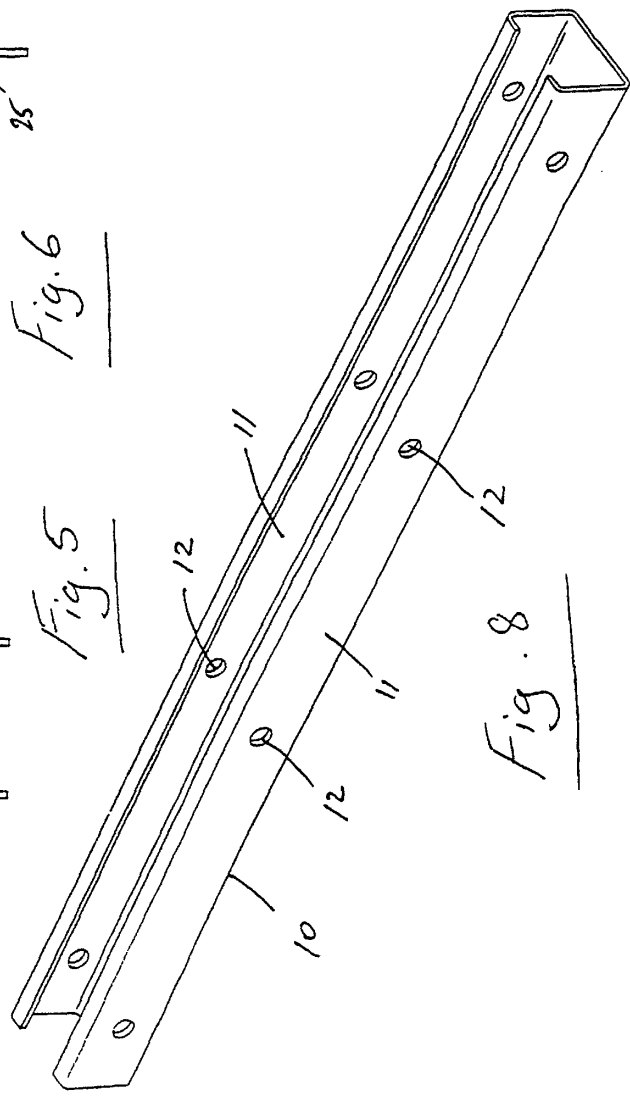
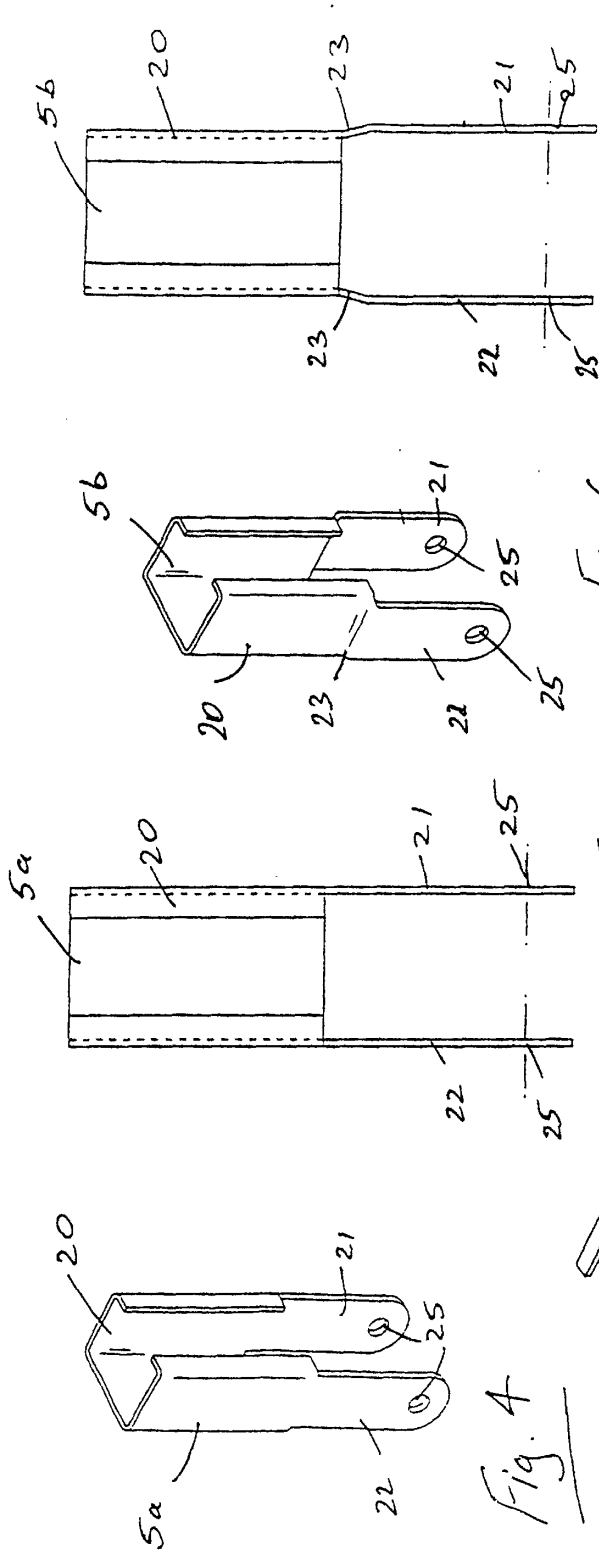

Fig. 3



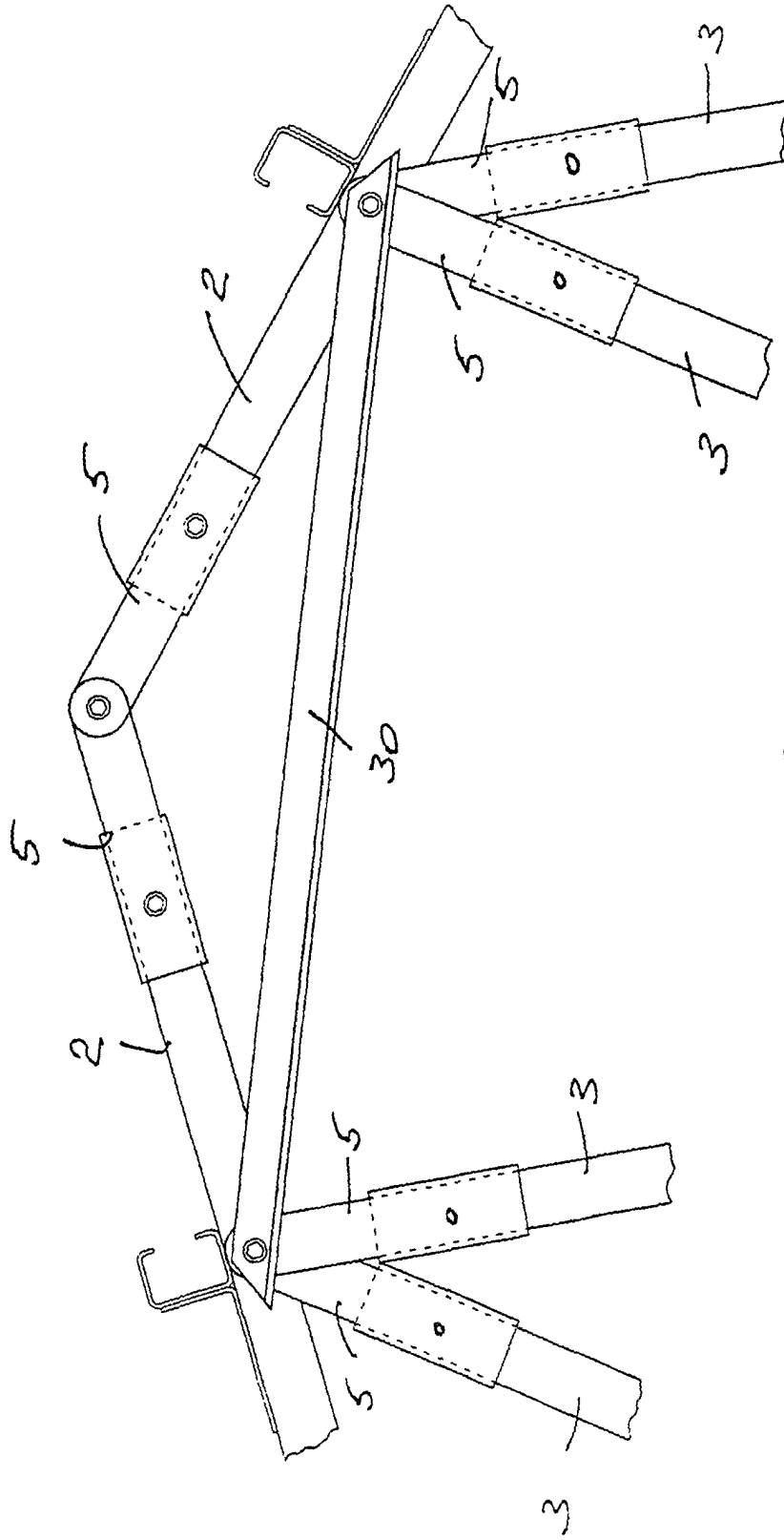

Fig. 9

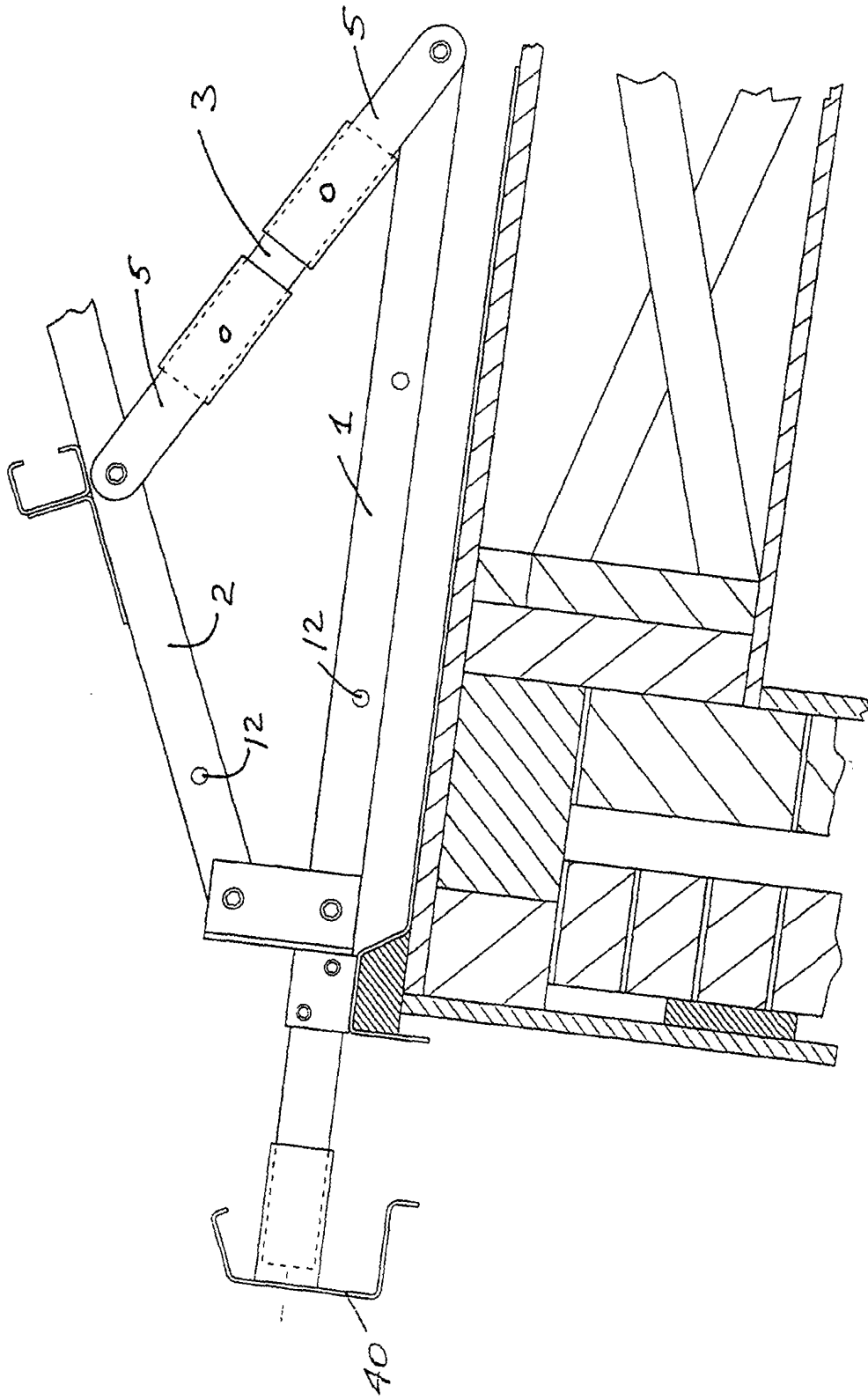

Fig. 10

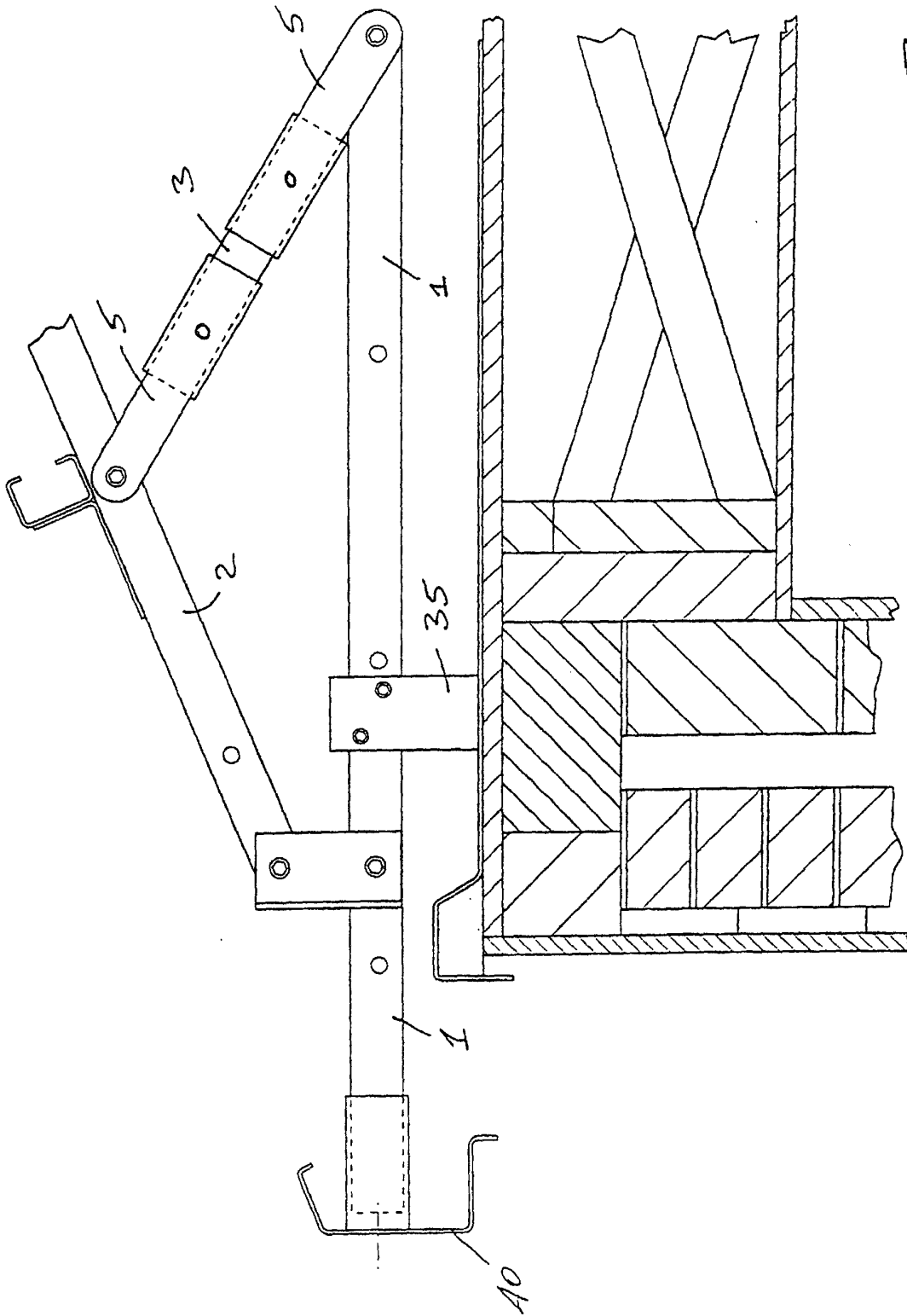

Fig. 11

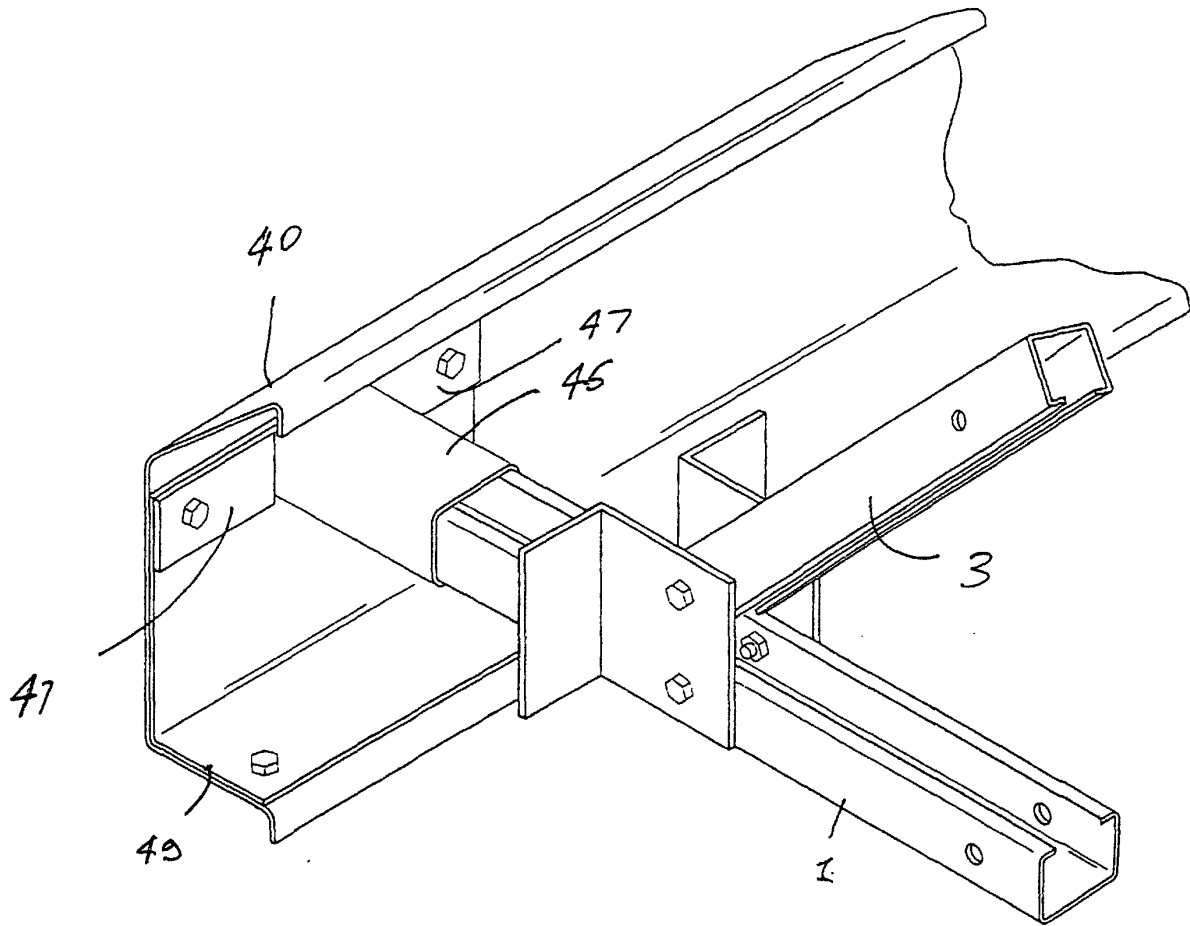

Fig. 12