

(19)



(11)

EP 2 662 130 A3

(12)

EUROPEAN PATENT APPLICATION

(88) Date of publication A3:
13.08.2014 Bulletin 2014/33

(51) Int Cl.:
B01F 5/04 (2006.01) **F23J 15/00** (2006.01)
B01F 3/02 (2006.01) **B01F 5/06** (2006.01)
B01F 5/00 (2006.01) **B01D 53/56** (2006.01)

(43) Date of publication A2:
13.11.2013 Bulletin 2013/46

(21) Application number: **13166810.5**

(22) Date of filing: **07.05.2013**

(84) Designated Contracting States:
AL AT BE BG CH CY CZ DE DK EE ES FI FR GB GR HR HU IE IS IT LI LT LU LV MC MK MT NL NO PL PT RO RS SE SI SK SM TR
 Designated Extension States:
BA ME

(71) Applicant: **Alstom Technology Ltd**
5400 Baden (CH)

(72) Inventors:
 • **Tabikh, Ali Mustapha**
352 53 Vaxjo (SE)
 • **Tu, Haitao**
100025 Beijing (CN)

(30) Priority: **10.05.2012 US 201261645296 P**
26.03.2013 US 201313850459

(54) Injector grid with two stage mixer and method

(57) An injector mixer arrangement (10) for supplying a reducing agent in gaseous form into a flue gas flowing in a gas duct (14) communicating with a catalyst (18a) in a selective catalytic reduction (SCR) reactor (12) arranged downstream of said injector mixer arrangement (10). The injector mixer arrangement (10) comprises an injector grid (22) equipped with a plurality of nozzles (30) arranged horizontally within the gas duct (14). The nozzles (30) are adapted to supply said reducing agent to the gas duct (14). The injector mixer arrangement (10) further comprises first stage mixer plates (24) and second stage mixer plates (26) arranged in the gas duct (14) downstream of said nozzles (30) and upstream of SCR reactor 12.

FIG. 1

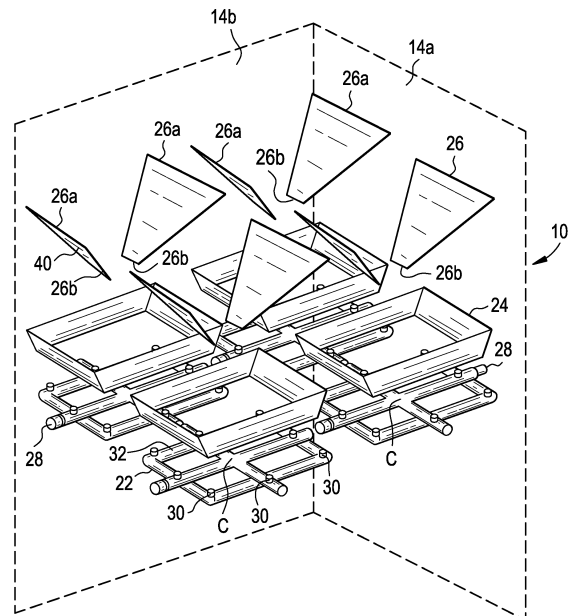

EP 2 662 130 A3



EUROPEAN SEARCH REPORT

Application Number
EP 13 16 6810

5

10

15

20

25

30

35

40

45

50

55

DOCUMENTS CONSIDERED TO BE RELEVANT				
Category	Citation of document with indication, where appropriate, of relevant passages	Relevant to claim	CLASSIFICATION OF THE APPLICATION (IPC)	
X	EP 0 526 393 A1 (SULZER AG [CH] SULZER CHEMTECH AG [CH]) 3 February 1993 (1993-02-03) * figures 2,5,7,10 * * abstract * * column 3, line 23 - column 5, line 43 * -----	1-20	INV. B01F5/04 F23J15/00 B01F3/02 B01F5/06 B01F5/00 B01D53/56	
X	EP 2 420 309 A1 (ALSTOM TECHNOLOGY LTD [CH]) 22 February 2012 (2012-02-22) * figures 1-7 * * paragraph [0022] - paragraph [0043] * -----	1,2,4-9, 11,12, 14-19		
X	US 2012/014209 A1 (SMITH ROBERT S [US]) 19 January 2012 (2012-01-19) * figures 1,2 * * abstract * -----	1,2,4-6, 8,9		
Y	DE 43 13 393 A1 (SIEMENS AG [DE]) 13 October 1994 (1994-10-13) * figures 1-3 * * abstract * -----	1-20		TECHNICAL FIELDS SEARCHED (IPC)
Y	US 8 017 084 B1 (WIRT JEFFREY PHILIP [US] ET AL) 13 September 2011 (2011-09-13) * figures 5-7 * * abstract * -----	1-20		B01F F23J B01D
A	US 4 981 368 A (SMITH CHARLES R [US]) 1 January 1991 (1991-01-01) * figures 2-7 * * abstract * -----	1-20		
E	EP 2 620 208 A1 (ALSTOM TECHNOLOGY LTD [CH]) 31 July 2013 (2013-07-31) * figures 1-5 * * abstract * -----	1,11		
The present search report has been drawn up for all claims				
Place of search The Hague		Date of completion of the search 8 July 2014	Examiner Krasenbrink, B	
CATEGORY OF CITED DOCUMENTS X : particularly relevant if taken alone Y : particularly relevant if combined with another document of the same category A : technological background O : non-written disclosure P : intermediate document		T : theory or principle underlying the invention E : earlier patent document, but published on, or after the filing date D : document cited in the application L : document cited for other reasons & : member of the same patent family, corresponding document		

1
EPC FORM 1503 03.02 (P04C01)

ANNEX TO THE EUROPEAN SEARCH REPORT
ON EUROPEAN PATENT APPLICATION NO.

EP 13 16 6810

5

This annex lists the patent family members relating to the patent documents cited in the above-mentioned European search report.
The members are as contained in the European Patent Office EDP file on
The European Patent Office is in no way liable for these particulars which are merely given for the purpose of information.

08-07-2014

10

Patent document cited in search report	Publication date	Patent family member(s)	Publication date	
EP 0526393	A1	03-02-1993	AT 141827 T	15-09-1996
			DE 59206987 D1	02-10-1996
			EP 0526393 A1	03-02-1993
			JP 3202798 B2	27-08-2001
			JP H05200262 A	10-08-1993
			US RE36969 E	28-11-2000
			US 5456533 A	10-10-1995
EP 2420309	A1	22-02-2012	CN 103153431 A	12-06-2013
			EP 2420309 A1	22-02-2012
			US 2013224081 A1	29-08-2013
			WO 2012023025 A1	23-02-2012
US 2012014209	A1	19-01-2012	NONE	
DE 4313393	A1	13-10-1994	NONE	
US 8017084	B1	13-09-2011	NONE	
US 4981368	A	01-01-1991	NONE	
EP 2620208	A1	31-07-2013	CN 103223310 A	31-07-2013
			EP 2620208 A1	31-07-2013
			TW 201402192 A	16-01-2014
			US 2013188440 A1	25-07-2013

15

20

25

30

35

40

45

50

55

EPO FORM P0459

For more details about this annex : see Official Journal of the European Patent Office, No. 12/82