



PCT

WORLD INTELLEC
TUAL

WO 9604947A1

INTERNATIONAL APPLICATION PUBLISHED UNDER THE PATENT COOPERATION TREATY (PCT)

(51) International Patent Classification ⁶ : A61M 5/307, C12M 3/00	A1	(11) International Publication Number: WO 96/04947
		(43) International Publication Date: 22 February 1996 (22.02.96)

(21) International Application Number: PCT/GB95/01948

(22) International Filing Date: 17 August 1995 (17.08.95)

(30) Priority Data:
9416663.4 17 August 1994 (17.08.94) GB

(71) Applicant (for all designated States except US): OXFORD BIOSCIENCES LIMITED [GB/GB]; The Magdalen Centre, The Oxford Science Park, Oxford OX4 4GA (GB).

(72) Inventors; and
(75) Inventors/Applicants (for US only): BELLHOUSE, Brian, John [GB/GB]; The Lodge, North Street, Islip, Oxfordshire OX5 2SQ (GB). DRAYSON, Paul, Rudd [GB/GB]; Bridge Cottage, Old Minster Lowell, Oxfordshire OX8 5RN (GB). GREENFORD, John, Christopher [GB/GB]; 11 Park Crescent, Abingdon, Oxfordshire OX14 1DF (GB). POTTER, Charles, David, Ogilvy [GB/GB]; 12 Grayling Close, Cambridge CB4 1NP (GB). SARPHIE, David, Francis [GB/GB]; 78 Hailey Road, Witney, Oxfordshire OX8 5SH (GB).

(74) Agent: GILL JENNINGS & EVERY; Broadgate House, 7 Eldon Street, London EC2M 7LH (GB).

(81) Designated States: AM, AT, AU, BB, BG, BR, BY, CA, CH, CN, CZ, DE, DK, EE, ES, FI, GB, GE, HU, IS, JP, KE, KG, KP, KR, KZ, LK, LR, LT, LU, LV, MD, MG, MK, MN, MW, MX, NO, NZ, PL, PT, RO, RU, SD, SE, SG, SI, SK, TJ, TM, TT, UA, UG, US, UZ, VN, European patent (AT, BE, CH, DE, DK, ES, FR, GB, GR, IE, IT, LU, MC, NL, PT, SE), OAPI patent (BF, BJ, CF, CG, CI, CM, GA, GN, ML, MR, NE, SN, TD, TG), ARIPO patent (KE, MW, SD, SZ, UG).

Published
*With international search report.
Before the expiration of the time limit for amending the claims and to be republished in the event of the receipt of amendments.*

(54) Title: PARTICLE DELIVERY

(57) Abstract

A needleless syringe comprising an elongate nozzle to the upstream end of which is connected a sealed chamber containing gas at super-atmospheric pressure and particles of a therapeutic agent, there being means for opening an outlet from the chamber to release the gas and particles entrained therewith so that they flow through the nozzle at supersonic speed.

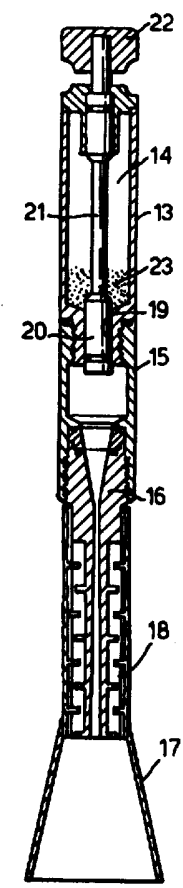

FOR THE PURPOSES OF INFORMATION ONLY

Codes used to identify States party to the PCT on the front pages of pamphlets publishing international applications under the PCT.

AT	Austria	GB	United Kingdom	MR	Mauritania
AU	Australia	GE	Georgia	MW	Malawi
BB	Barbados	GN	Guinea	NE	Niger
BE	Belgium	GR	Greece	NL	Netherlands
BF	Burkina Faso	HU	Hungary	NO	Norway
BG	Bulgaria	IE	Ireland	NZ	New Zealand
BJ	Benin	IT	Italy	PL	Poland
BR	Brazil	JP	Japan	PT	Portugal
BY	Belarus	KE	Kenya	RO	Romania
CA	Canada	KG	Kyrgystan	RU	Russian Federation
CF	Central African Republic	KP	Democratic People's Republic of Korea	SD	Sudan
CG	Congo	KR	Republic of Korea	SE	Sweden
CH	Switzerland	KZ	Kazakhstan	SI	Slovenia
CI	Côte d'Ivoire	LI	Liechtenstein	SK	Slovakia
CM	Cameroon	LK	Sri Lanka	SN	Senegal
CN	China	LU	Luxembourg	TD	Chad
CS	Czechoslovakia	LV	Larvia	TG	Togo
CZ	Czech Republic	MC	Monaco	TJ	Tajikistan
DE	Germany	MD	Republic of Moldova	TT	Trinidad and Tobago
DK	Denmark	MG	Madagascar	UA	Ukraine
ES	Spain	ML	Mali	US	United States of America
FI	Finland	MN	Mongolia	UZ	Uzbekistan
FR	France			VN	Viet Nam
GA	Gabon				

PARTICLE DELIVERY

In our earlier international patent application No. WO 94/24263, we disclose a non-invasive drug delivery system involving the use of a needleless syringe which fires light drug-containing particles in controlled doses into the intact skin or delivers genetic material into living cells. The syringe described in the earlier application is constructed as an elongate tubular nozzle, a rupturable membrane initially closing the passage through the nozzle adjacent to the upstream end of the nozzle, particles of a therapeutic agent, particularly a powdered therapeutic agent, located adjacent to the membrane, and energizing means for applying to the upstream side of the membrane a gaseous pressure sufficient to burst the membrane and produce through the nozzle a supersonic gas flow in which the particles are entrained.

By appropriate selection of the geometry and Mach number for the nozzle, which preferably has a convergent upstream portion, leading through a throat to a cylindrical or, preferably, divergent downstream portion, it has been possible to provide a pseudo-steady state, supersonic two phase flow through the nozzle, in which the particles move with a velocity close to that of the propelling gas in which they are entrained. Consequently, a large proportion of the particles reach the target under quasi-steady flow conditions and only a small proportion are delivered in transient flow and carried on the contact surface. This leads to considerable benefit both in control and in increased skin or other target penetration and is surprising in such a transient phenomenon. High speed photography of the gas/drug jet has confirmed the quasi-steady flow conditions. Typical photographs of the jet show the jet lasting for 1.5 milliseconds, with reasonably homogenous distribution of the drug particles throughout the jet. The length of time that the jet lasts allows us to calculate the effective length of the jet and hence its

volume. This allows us to conclude that the drug particles are arriving in a continuous flow at the skin surface and that on average succeeding particles will penetrate in the same holes as preceding particles, reducing damage and trauma to the skin. This understanding has led to our appreciation that the drug dose may be advantageously mixed with the driving gas in the gas canister. The drug delivery system can then be considerably simplified as a rupturable membrane may, in most cases, no longer be needed. Now the outlet from the chamber may lead directly to the nozzle via a valve or other means for releasing the gas. This differentiates our technique from other prior art, such as EPA-0535005, which relies upon the impact of a shock wave to accelerate particles, whereas our technique accelerates them in a flow of gas.

In accordance with the invention, a needleless syringe is constructed as an elongate nozzle at the upstream end of which is provided a sealed chamber containing gas at superatmospheric pressure and particles of a therapeutic agent, there being means for opening an outlet from the chamber to release the gas and particles entrained therewith so that they flow through the nozzle at supersonic speed. The location of the particles within the chamber which contains the high pressure gas considerably simplifies the construction and assembly of the syringe.

The outlet from the chamber may incorporate a pierceable membrane or a valve, such as a spring-loaded ball valve, which is pierced or opened by manual manipulation, such as by movement of two parts of the syringe relatively to one another.

The chamber may contain a single dose of particles, and hence sufficient gas for a single shot. Alternatively, the outlet from the chamber may incorporate a valve which may be opened and closed a consecutive number of times to deliver a succession of doses of the therapeutic agent. The time during which the valve is opened may be automatically controlled by control means, for example

including a solenoid or stepping motor the valve being opened for successively longer periods to deliver equal doses of therapeutic agent in spite of the successively reducing pressure in the chamber. It will then be appreciated that by placing the drug in the gas canister, creating a homogeneous mixing and suspension of the powdered drug and by using a fast opening metering valve at the exit of the canister, a multi-shot syringe may be created, dispensing an infinitely variable, rather than a unit, dose of drug. By combining the metering valve with a timing device, the duration of time that the valve is open for each shot may be controlled. The timer may be adjusted to take account of the desired dose of drug, the gas pressure in the reservoir and the drug concentration in the reservoir (both of which will decrease with each shot). If the initial values of the drug mass and the gas pressure in the reservoir are known, then the required duration of each subsequent shot can be calculated, eg by a microprocessor, and the timer adjusted accordingly.

Alternatively, when the actual dose is not critical, for example when the therapeutic agent is an analgesic, the valve may be opened and closed manually. A degree of control may then be provided by means of a rupturable membrane between the valve and the nozzle, the valve being opened to release sufficient gas and particles into a rupture chamber upstream of the membrane until the pressure across the membrane has built up sufficiently for the membrane to rupture, whereafter the particles, entrained in the gas, are free to flow from the rupture chamber through the nozzle to the target. As soon as the operator hears the membrane burst, he will reclose the valve, for example by releasing a trigger which holds the valve open against the spring pressure.

The sealed chamber containing the gas under pressure and the particles may be supplied as a separate unit to be united, at the time of use, with another part of the

syringe incorporating the tubular nozzle, and possibly also a diaphragm-piercing or valve-opening device.

One slight disadvantage with the earlier syringe, in which gas pressure was used to burst the rupturable membrane, was the difficulty in ensuring that the full prescribed dose of particles was delivered in the gas flow, without any remaining in the proximity of the remnants of the burst membrane. With the new syringe, this disadvantage can be overcome if the particles are initially located in one or more open ended passageways within the chamber, and arranged such that upon opening of the outlet and release of the compressed gas, at least some of this gas sweeps through the passageway(s) and thus entrains substantially all the particles within the passageway(s). The particles may be initially retained in the passageways under gravity, or electrostatically, or by means of weak membranes closing the ends of the passageways until ruptured by the release of pressure. Another solution involves making the particles of drug to be so small as to remain suspended in the gas for a few seconds when agitated but big enough so as to not enter the skin cells and reduce bio-availability. On the contrary, the drug particles occupy extra-cellular space and hence diffuse readily into the systemic circulation. Particle diameters of between 10-20 μ m are preferable. A ball bearing may be placed inside the gas canister to help homogenous distribution of the drug upon shaking, prior to firing.

Study of the drug jet and its arrival at the target surface has further led to the appreciation that the jet dimensions are important and affect the concentration of drug per unit volume of target skin. By increasing the volume of driver gas one may lengthen the duration of the jet and increase the dosage of drug that may be delivered, subject to the limitation of drug concentration that is viable in the skin. For a given concentration, dosage delivered may also be increased by increasing target skin area. This may be achieved by increasing the diameter of

the throat of the nozzle, whilst maintaining constant the ratio of inlet and exit diameters. Target diameter may also be increased by increasing the spacing distance of the nozzle exit from the target.

5 In other respects, for example in the use of a spacer/silencer at the downstream end of the nozzle, in the nozzle geometry, in the type of particle which may be delivered, and in the type and pressure of gas to be used, reference is made to the earlier application.

10 Some examples of syringes constructed in accordance with the present invention are illustrated diagrammatically in the accompanying drawings, in which:

Figure 1 is an axial section through a first example;

Figure 2 is a side elevation of the first example;

15 Figures 3 and 4 correspond to Figures 1 and 2 but show a second example;

Figures 5 and 6 show, to an enlarged scale, parts of Figures 3 and 4;

20 Figures 7 and 8 correspond to Figures 5 and 6 but show a third example;

Figures 9 and 10 correspond to Figures 1 and 2 but show a fourth example;

Figure 11 is a diagrammatic axial view of a canister;

25 Figure 12 is a section taken on the XII-XII in Figure 11;

Figure 13 is an exploded view of another example;

Figure 14 is an enlargement of part of Figure 13; and,

Figure 15 is a view of a further example.

30 The syringe shown in Figures 1 and 2 is almost identical to the syringe shown in Figures 1 to 3 of the earlier application WO 94/24263, in having an upper barrel portion 13 containing a sealed reservoir or chamber 14 and coupled by screw threads via a lower barrel portion 15 to a nozzle 16 associated with a spacer 17 and silencer 18.

35 An outlet 19 in the bottom of the chamber 14 is closed by a valve element 20 on the end of a plunger 21 which is depressible by a button 22. The syringe differs from that

in the earlier application in not having at the top, upstream end of the nozzle 16 a capsule consisting of two rupturable membranes between which the particles of therapeutic agent are isolated. Instead, these particles
5 23 are located within the chamber 14. When the particles are to be delivered, the button 22 is depressed thereby moving the sealed carrying part of the element 20 downwardly out of the outlet 19, and releasing the compressed gas and particles in the chamber 14 to flow at
10 supersonic speed through the nozzle 16 to a target positioned beyond the spacer 17.

The syringe shown in Figures 3 to 6 differs from that shown in Figures 1 and 2 in that the chamber 14 is provided within a canister 24 which is slidable within a sleeve 25
15 corresponding to the upper barrel portion 13 in the first example. An outlet 19A is closed by a valve consisting of a ball closure element 26 which is urged onto a seating 27 by a helically coiled compression spring 28. Within the lower barrel portion 15A there is provided an upwardly
20 projecting spigot 29 which can enter the outlet 19A and, when the upper end of the canister 24 is pressed downwardly into the upper barrel portion 25, displaces the ball closure element 26 from its seat and allows sudden release of the gas and particles which are contained within the
25 chamber 14. The valve may be reclosed, for multi shot use by releasing the pressure on the canister.

The modification shown in Figures 7 and 8 differs from that of the Figures 3 to 6 example only in that a thumb piece 28 is pivotally mounted in the top of the barrel
30 portion 25 by means of a lug on the thumb piece engaging an aperture 30 in the barrel portion. Depression of the thumb piece forces the bulb 24 downwards within the barrel portion 25 and provides a mechanical advantage which facilitates movement of the ball closure element against
35 the high pressure within the chamber 14.

Figures 9 and 10 show an alternative way of forcing the canister 24 downwardly to open the ball valve. In this

example a cylindrical shroud 31 is slipped down over the canister 24 and its lower end 32 slides on the lower barrel portion 15A. Downward pressure on the closed upper end of the shroud 31 forces the canister 24 downwards to open the valve.

The pressure containing parts of the syringe will usually be made of metal, but may also be made of a rigid engineering plastics material, such as a polycarbonate. A canister 24A made of such plastics material is shown in Figures 11 and 12. The body of the canister is made in two parts 33 and 34 which are fused or welded together. The canister contains an insert 35 consisting of a number of parallel cylindrical passageways 36. Upon assembly, the canister is filled with high pressure gas and the particles of therapeutic agent are located within the passageways 36. An outlet 37 of the canister may be fitted with a ball valve such as in the previous examples, or closed by means of a pierceable diaphragm which is sufficiently strong to contain the internal gas pressure but which may be readily breached by a needle, which may be hollow, when the canister is moved relatively to the needle.

Figures 13 and 14 show a multi dose syringe which comprises a canister 38 containing compressed gas and particles of therapeutic agent, together with an agitator, such as a metal ball. Prior to discharge, the canister is shaken so that the particles are suspended in the gas and entrained by the gas when it is released.

Screwed into the lid of the canister is a valve housing 39 containing a valve chamber having a lower side passage 41 leading down into the canister 38 into which it opens, and an upper side passage 42 into which is screwed a nozzle assembly 43 consisting of a rupture chamber 44 and a nozzle 45 separated by a rupturable membrane 46. A plunger 47 extends into the valve chamber 40 and carries an O sealing ring 48. The plunger is urged upwardly by a helically coil compression spring 49 so that the ring 48 is above the side passage 41. When the plunger 47 is

depressed against the action of the spring, by downward displacement of an L-shaped lever 50, which is pivoted to the valve housing 39, the ring 48 rides to below the passage 41, allowing the escape of a suspension of the particles in the conveying gas from the canister 38 and into the rupture chamber 44. When the pressure in the chamber 44 has built up sufficiently, the membrane 46 bursts and the particles, entrained in a supersonic gas flow, are ejected through the nozzle 45. The lever 50 is conveniently manipulated by grasping the canister 38 in the palm of the user's hand, and depressing the free end of the lever with the thumb. As soon as the user hears the membrane burst, the lever 50 can be released, so that the plunger 47 is raised under the action of the spring 49, effectively reclosing the valve ready for a subsequent shot, prior to which the membrane 46 will need to be replaced, for example by unscrewing the nozzle 45 from the part of the assembly 43 containing the rupture chamber 44.

The system shown in Figure 15 differs from that of Figure 13 and 14 in that the canister 38 of gas and particles is connected to the nozzle 45 via tubing 50, which may be rigid or flexible, containing a pressure regulator 51 and a pressure indicator 52, and a valve 53. The valve is a fast acting valve which is controlled by a solenoid or stepping motor 54 under the control of a micro processor 55, which is connected to the control 54 by an umbilical 56. In this example the valve 53 is opened according to the timing programme of the micro processor 55, for a predetermined time to cause the required dose to be ejected through the nozzle 45. The micro processor will be programmed not only with the required dose but with the initial pressure in the canister 38 and the concentration of particles of therapeutic agent, so that the required dose can be repeated irrespective of reducing pressure in the canister 38.

Typically, in each of the illustrated examples, the gas provided in the chamber 14 may be helium at a pressure

of the order of 40 to 80 bar. The nozzle may be of convergent/divergent, or convergent/cylindrical form with a length of between 50 and 100, preferably 60mm, and a throat diameter of between 1 and 10, preferably between 1.5 and 5mm. With appropriate gas pressure, particles having a diameter of 10-40 μ m will be accelerated through the nozzle to velocities of between Mach 1 and 3.

CLAIMS

1. A needleless syringe comprising an elongate nozzle (16, 45) to the upstream end of which is connected a sealed chamber (14, 38) containing gas at super-atmospheric pressure and particles of a therapeutic agent, there being means (20, 26, 47, 53) for opening an outlet (19) from the chamber to release the gas and particles entrained therewith so that they flow through the nozzle at supersonic speed.
2. A syringe according to claim 1, in which the outlet from the chamber incorporates a pierceable membrane or a valve which is arranged to be pierced or opened, respectively, by manual manipulation.
3. A syringe according to claim 2, in which the manual manipulation involves movement of two parts of the syringe relatively to one another.
4. A syringe according to claim 2, in which the outlet from the chamber incorporates a valve which may be opened and closed a consecutive number of times, to deliver a succession of doses of the therapeutic agent.
5. A syringe according to claim 4, in which the time during which the valve is opened is automatically controlled by control means, and the valve is opened for successively longer periods to deliver equal and selected doses of therapeutic agent in spite of the successively reducing pressure in the chamber.
6. A syringe according to claim 4 or claim 5, in which the control means includes a solenoid or stepping motor.
7. A syringe according to any one of the preceding claims, in which the sealed chamber contains one or more

open ended passages and arranged such that, upon opening of the outlet, and release of the compressed gas, at least some of this gas sweeps through the passageway(s) and entrains the particles within the passageway.

1/8

Fig.1.

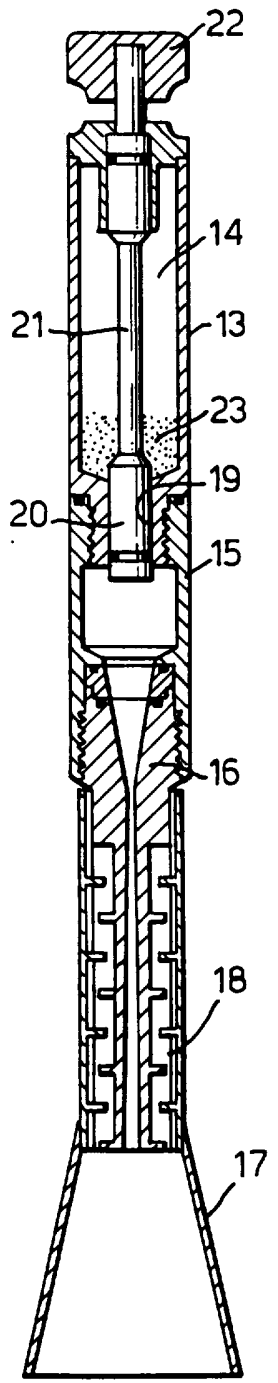

Fig.2.

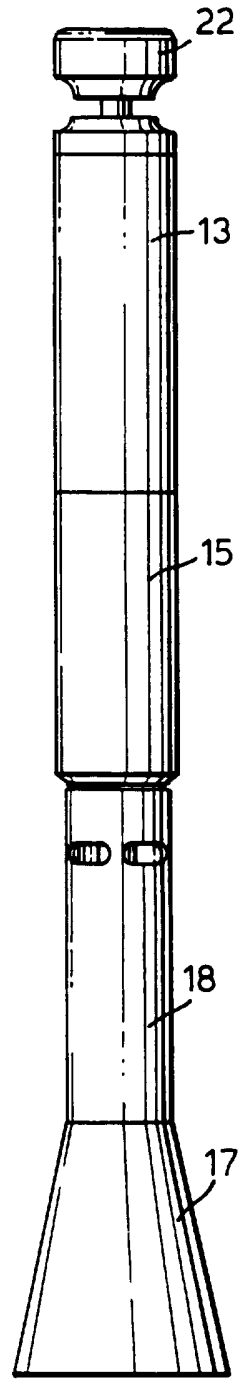

Fig.3.

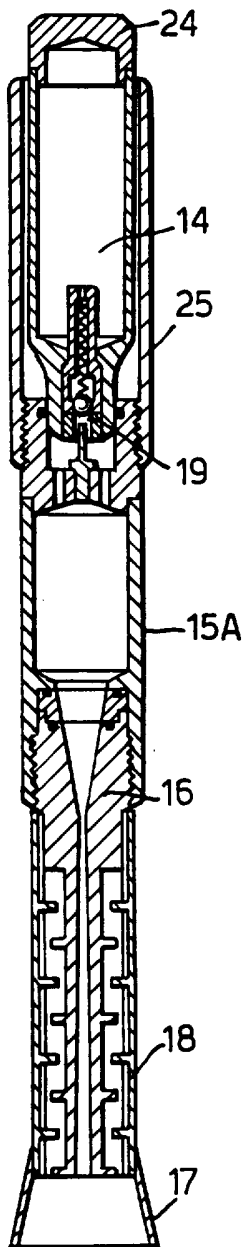

Fig.4.

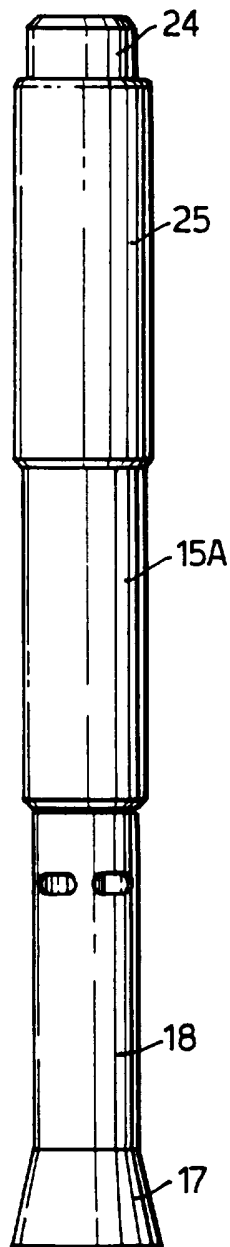

Fig.5.

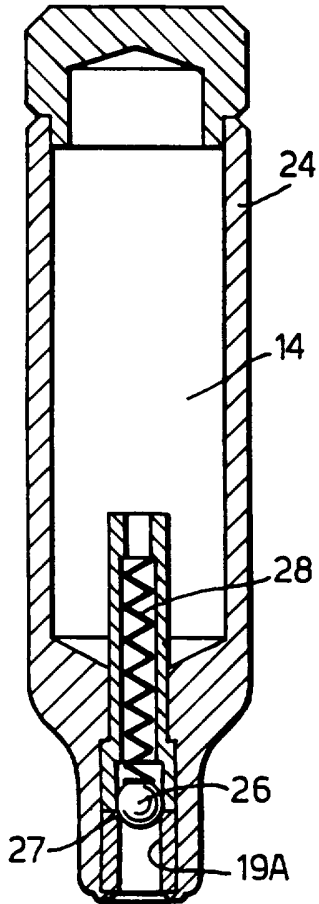
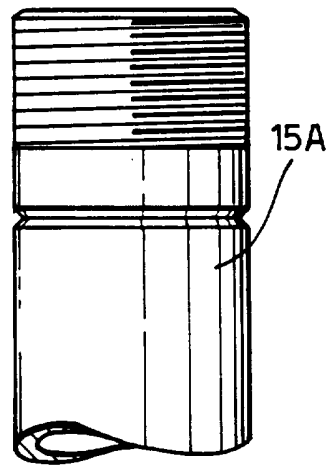
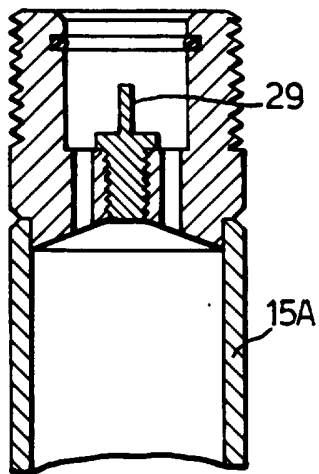
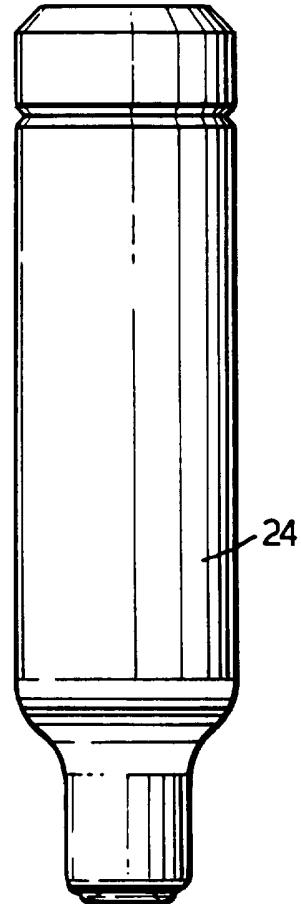

Fig.6.



4/8

Fig.7.

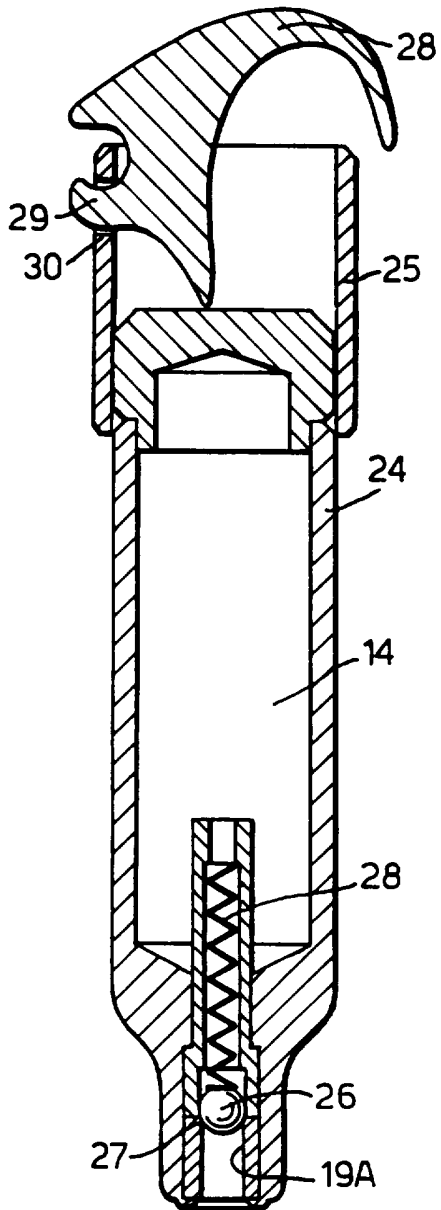

Fig.8.

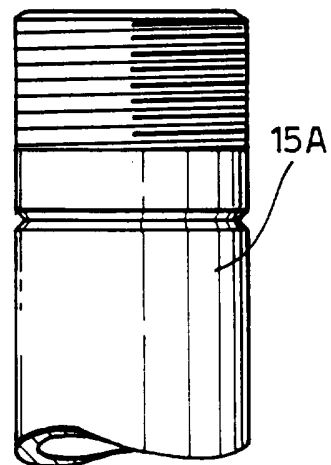
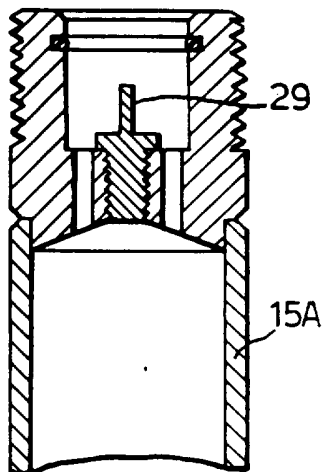
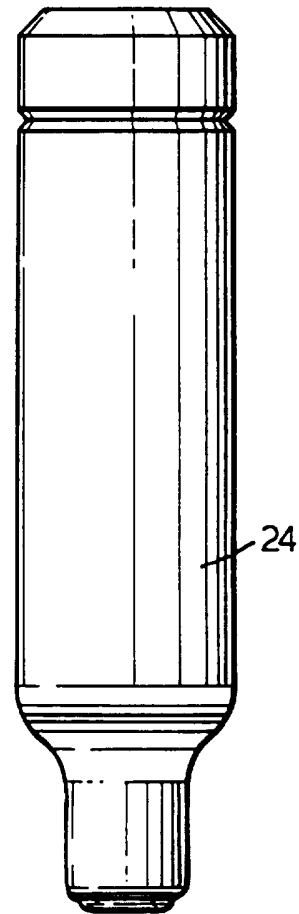

Fig.9.

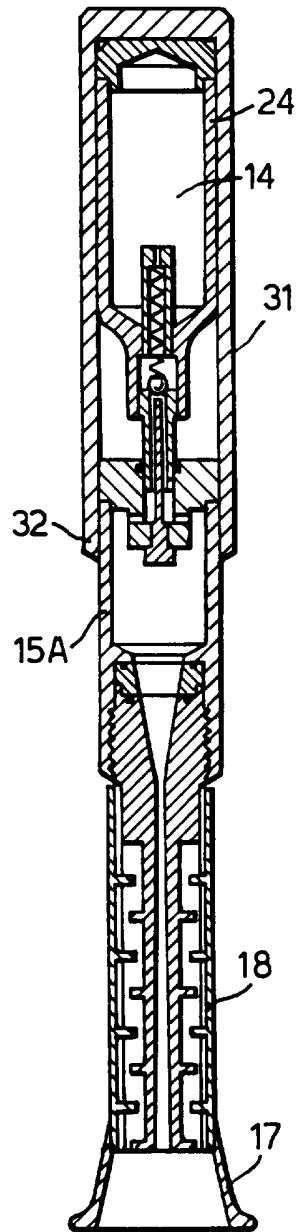

Fig.10.

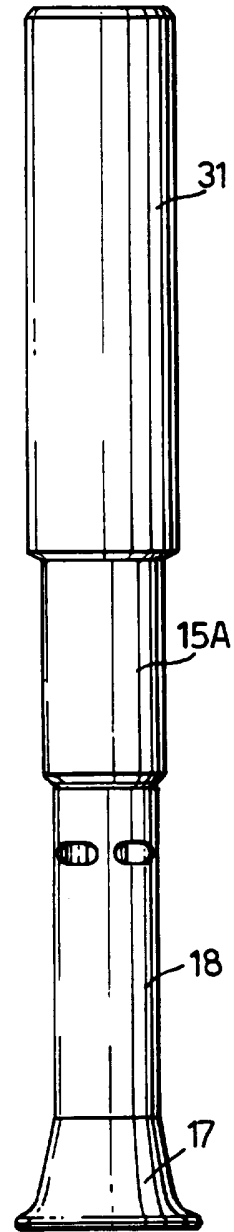

Fig.11.

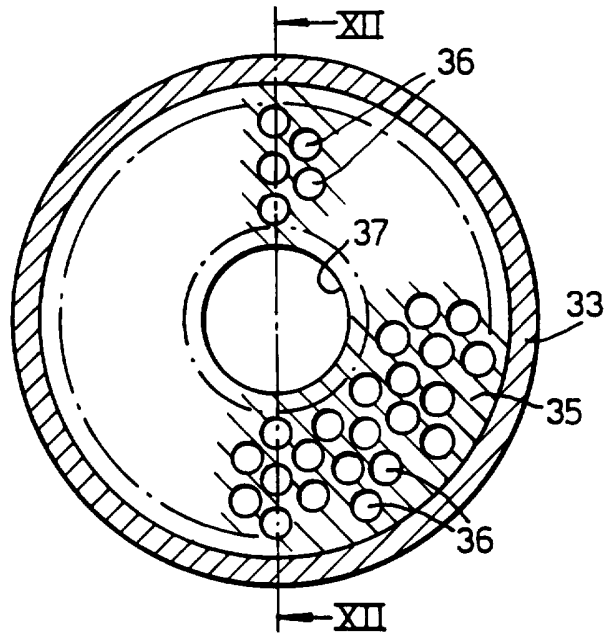
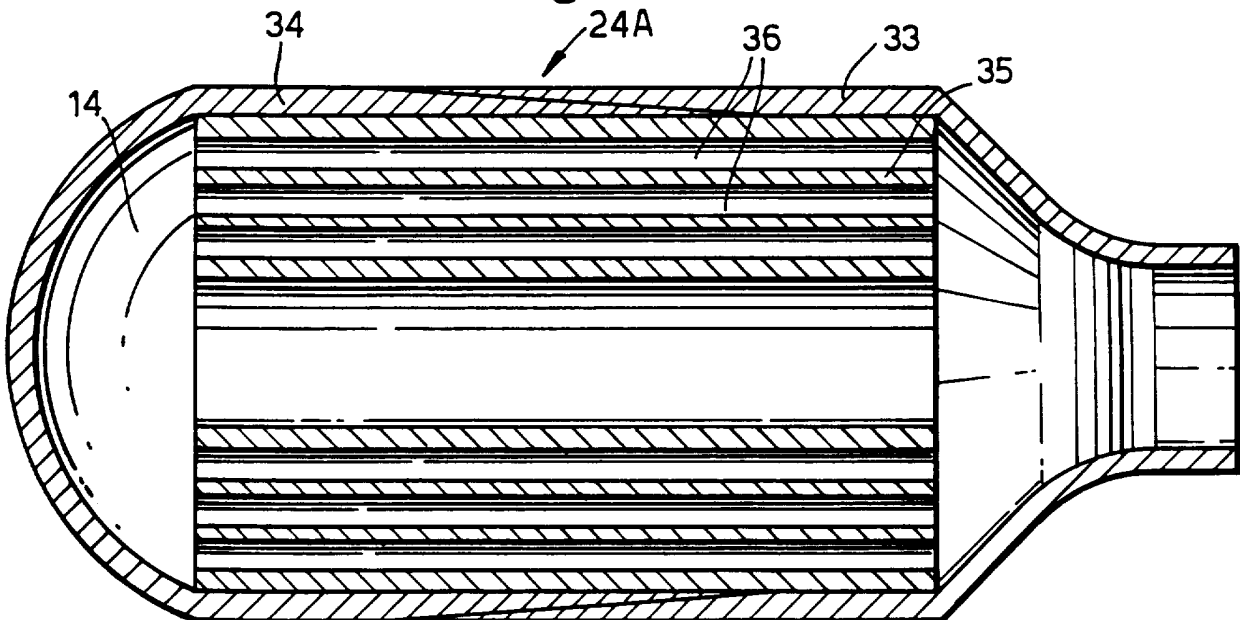

Fig.12.



7/8

Fig.13.

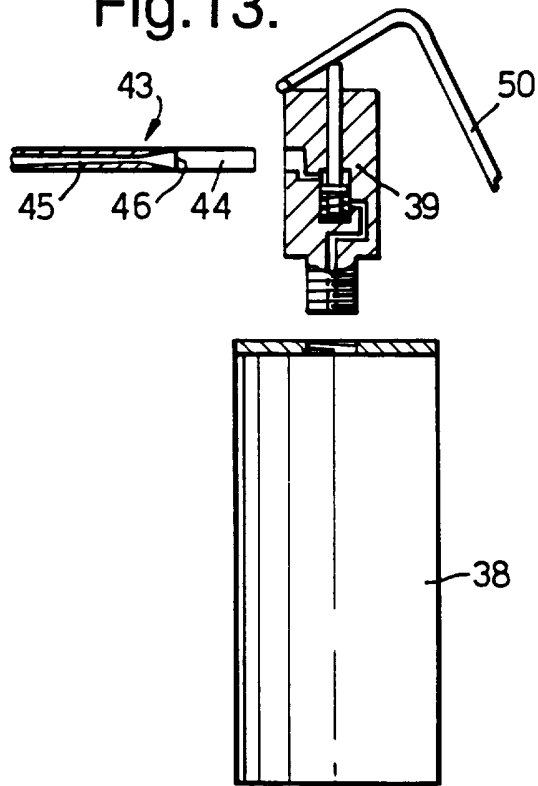

Fig.14.

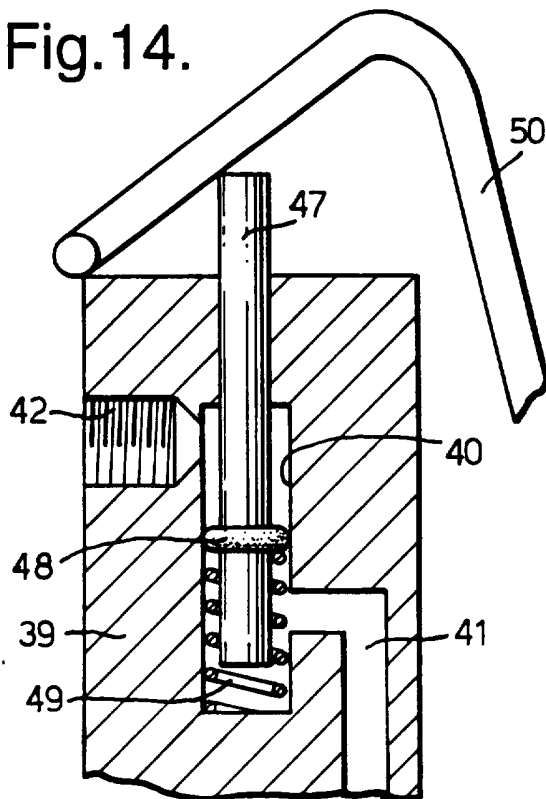
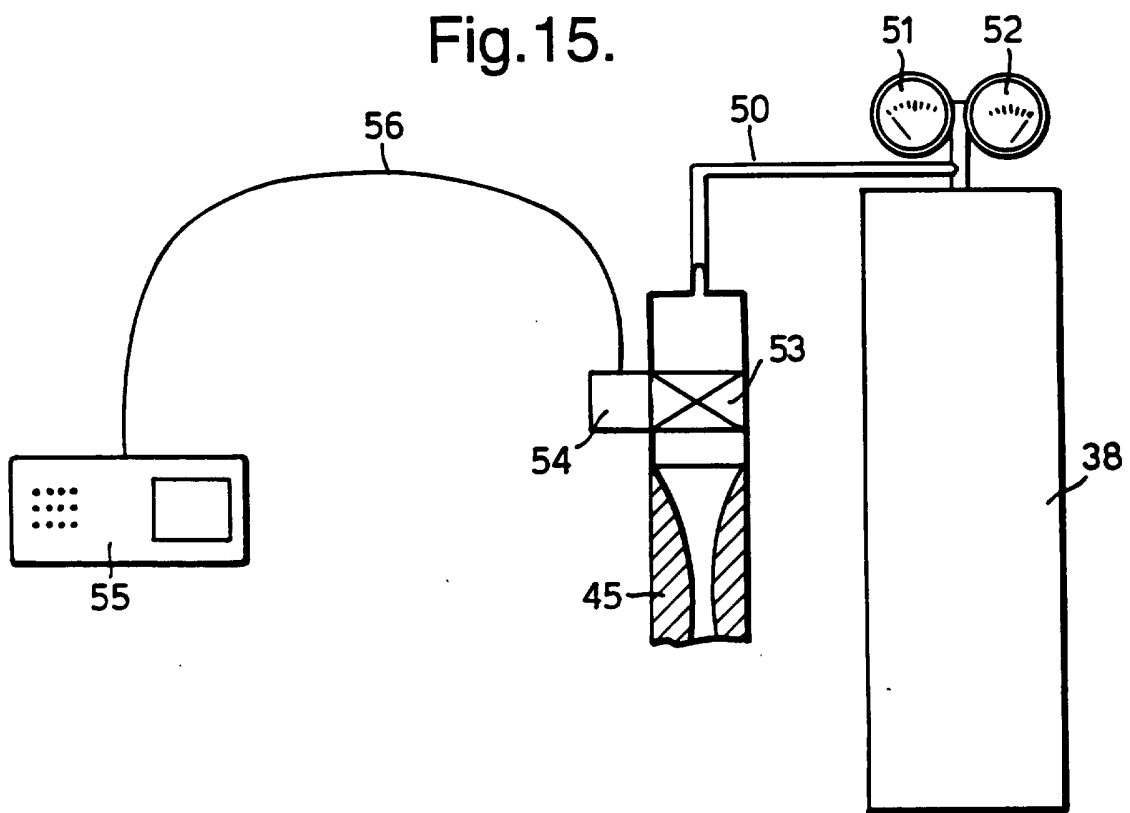

Fig.15.



INTERNATIONAL SEARCH REPORT

Internatic Application No PCT/GB 95/01948

A. CLASSIFICATION OF SUBJECT MATTER
IPC 6 A61M5/307 C12M3/00

According to International Patent Classification (IPC) or to both national classification and IPC

B. FIELDS SEARCHED

Minimum documentation searched (classification system followed by classification symbols)
IPC 6 A61M C12M

Documentation searched other than minimum documentation to the extent that such documents are included in the fields searched

Electronic data base consulted during the international search (name of data base and, where practical, search terms used)

C. DOCUMENTS CONSIDERED TO BE RELEVANT

Category *	Citation of document, with indication, where appropriate, of the relevant passages	Relevant to claim No.
A	DE,B,11 00 883 (AMPIN AKTIEBOLAG) 2 March 1961 see page 1, line 46 - page 4, line 11 see figure 1 ---	1-4
A	GB,A,1 049 780 (AMPINS LIMITED) 29 November 1963 see page 1, line 23 - line 62 see figures 1,2 ---	1
A	WO,A,91 00915 (BIOTECHNOLOGY RESEARCH) 24 January 1991 see page 5, line 26 - page 6, line 33 see page 9, line 1 - page 11, line 27 see figure 1 -----	1

Further documents are listed in the continuation of box C. Patent family members are listed in annex.

* Special categories of cited documents :

<p>*A* document defining the general state of the art which is not considered to be of particular relevance</p> <p>*E* earlier document but published on or after the international filing date</p> <p>*L* document which may throw doubts on priority claim(s) or which is cited to establish the publication date of another citation or other special reason (as specified)</p> <p>*O* document referring to an oral disclosure, use, exhibition or other means</p> <p>*P* document published prior to the international filing date but later than the priority date claimed</p>	<p>*T* later document published after the international filing date or priority date and not in conflict with the application but cited to understand the principle or theory underlying the invention</p> <p>*X* document of particular relevance; the claimed invention cannot be considered novel or cannot be considered to involve an inventive step when the document is taken alone</p> <p>*Y* document of particular relevance; the claimed invention cannot be considered to involve an inventive step when the document is combined with one or more other such documents, such combination being obvious to a person skilled in the art.</p> <p>*&* document member of the same patent family</p>
--	--

Date of the actual completion of the international search 25 January 1996	Date of mailing of the international search report 01.02.96
---	---

Name and mailing address of the ISA European Patent Office, P.B. 5818 Patentlaan 2 NL - 2280 HV Rijswijk Tel. (+31-70) 340-2040, Tx. 31 651 epo nl, Fax: (+31-70) 340-3016	Authorized officer Schönleben, J
--	--

INTERNATIONAL SEARCH REPORT

Information on patent family members

Internatic Application No

PCT/GB 95/01948

Patent document cited in search report	Publication date	Patent family member(s)	Publication date
DE-B-1100883		NONE	
GB-A-1049780		NONE	
WO-A-9100915	24-01-91	AU-B- 642889	04-11-93
		AU-B- 5950090	06-02-91
		EP-A- 0482125	29-04-92
		IE-B- 61705	30-11-94
		US-A- 5240842	31-08-93