



- (51) International Patent Classification: *C12M 3/00* (2006.01)
- (21) International Application Number: PCT/US2016/040855
- (22) International Filing Date: 1 July 2016 (01.07.2016)
- (25) Filing Language: English
- (26) Publication Language: English
- (30) Priority Data: 62/188,332 2 July 2015 (02.07.2015) US
- (71) Applicant: TERUMO BCT, INC. [US/US]; 10811 West Collins Avenue, Lakewood, CO 80215 (US).
- (72) Inventors: JONES, Mark, E.; 11976 Blacktail Mountain, Littleton, CO 80127 (US). NANKERVIS, Brian, J.; 8155 East 134th Place, Thornton, CO 80602 (US). FUERST, Kristina, E.; 1116 E. 13th Avenue, Unit C4, Denver, CO 80218 (US). DODD, Jon, A.; 6264 S. Van Gordon Way, Littleton, CO 80127 (US).
- (74) Agent: PEREYRA, René, A.; Mail Stop 810 1F2, 10811 West Collins Avenue, Lakewood, CO 80215 (US).
- (81) Designated States (unless otherwise indicated, for every kind of national protection available): AE, AG, AL, AM, AO, AT, AU, AZ, BA, BB, BG, BH, BN, BR, BW, BY, BZ, CA, CH, CL, CN, CO, CR, CU, CZ, DE, DK, DM, DO, DZ, EC, EE, EG, ES, FI, GB, GD, GE, GH, GM, GT, HN, HR, HU, ID, IL, IN, IR, IS, JP, KE, KG, KN, KP, KR,

[Continued on next page]

(54) Title: CELL GROWTH WITH MECHANICAL STIMULI

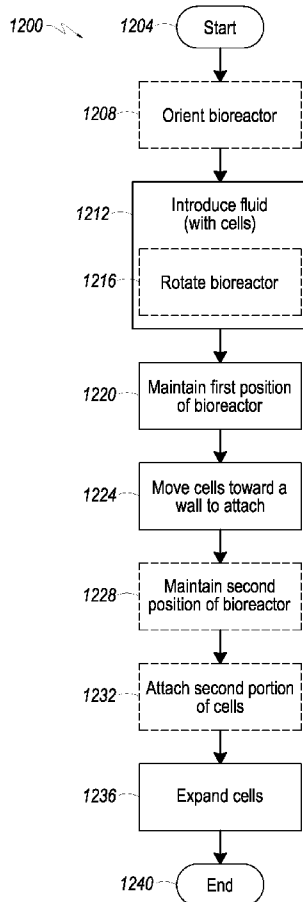
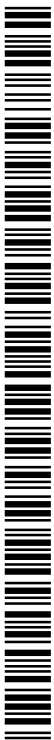

FIG. 12

(57) Abstract: Embodiments for loading and expanding particular cell types are described. Embodiments may include the use of hollow fiber membranes with particular characteristic such as hollow fibers with inner diameters that provide mechanical stimulus (e.g., radius of curvature greater than a dimension of a cell). In addition, embodiments may provide for manipulation of flow rates and other features that also provide mechanical stimuli and promote or enhance the growth of particular types of cells.



WO 2017/004592 A1



KZ, LA, LC, LK, LR, LS, LU, LY, MA, MD, ME, MG, MK, MN, MW, MX, MY, MZ, NA, NG, NI, NO, NZ, OM, PA, PE, PG, PH, PL, PT, QA, RO, RS, RU, RW, SA, SC, SD, SE, SG, SK, SL, SM, ST, SV, SY, TH, TJ, TM, TN, TR, TT, TZ, UA, UG, US, UZ, VC, VN, ZA, ZM, ZW.

(84) Designated States (unless otherwise indicated, for every kind of regional protection available): ARIPO (BW, GH, GM, KE, LR, LS, MW, MZ, NA, RW, SD, SL, ST, SZ, TZ, UG, ZM, ZW), Eurasian (AM, AZ, BY, KG, KZ, RU, TJ, TM), European (AL, AT, BE, BG, CH, CY, CZ, DE, DK, EE, ES, FI, FR, GB, GR, HR, HU, IE, IS, IT, LT, LU, LV, MC, MK, MT, NL, NO, PL, PT, RO, RS, SE, SI, SK, SM, TR), OAPI (BF, BJ, CF, CG, CI, CM, GA, GN, GQ, GW, KM, ML, MR, NE, SN, TD, TG).

Declarations under Rule 4.17:

- as to applicant's entitlement to apply for and be granted a patent (Rule 4.17(ii))
- as to the applicant's entitlement to claim the priority of the earlier application (Rule 4.17(iii))

Published:

- with international search report (Art. 21(3))
- before the expiration of the time limit for amending the claims and to be republished in the event of receipt of amendments (Rule 48.2(h))

CELL GROWTH WITH MECHANICAL STIMULI

Cross-Reference to Related Application(s)

[0001] This patent application claims priority to U.S. Provisional Patent Application No. 62/188,332 entitled "ENDOTHELIAL CELL GROWTH," filed July 2, 2015 and hereby incorporated by reference in its entirety as if set forth herein in full.

Background

[0002] Cell Expansion Systems (CESs) may be used to expand and differentiate a variety of cell types that may be used for both research and therapeutic purposes. Some cell types may positively respond to mechanical stimuli when expanded. In other words, subjecting the cell types to mechanical stimuli enhances their growth and proliferation. One example of a cell type that is a candidate to be grown in a CES and that responds positively to mechanical stimulus is endothelial cells. Endothelial cells play an important role in the development of vascular remodeling. As such, there is a need to design expansion methods for regenerative medicine that take into consideration the growing conditions that that may be used to efficiently grow cells, such as endothelial cells, ex vivo.

[0003] Embodiments of the present invention have been made in light of these and other considerations. However, the relatively specific problems discussed above do not limit the applicability of the embodiments of the present invention.

Summary

[0004] The summary is provided to introduce aspects of some embodiments of the present invention in a simplified form, and is not intended to identify key or essential elements of the present invention, nor is it intended to limit the embodiments of the present invention.

[0005] Embodiments provide for methods and apparatuses that may be used in growing particular cell types that show improved growth/proliferation in response to

mechanical stimulus, such as endothelial cells. Embodiments may include the use of hollow fiber membranes that may have inner diameters that provide a radius of curvature greater than a dimension (e.g., length or diameter) of a cell. In addition, embodiments may provide an undulating surface, pulsating flow rates, and other features that provide mechanical stimuli, which promotes or enhances the growth of the cells.

Brief Description of the Drawings

[0006] Non-limiting and non-exhaustive embodiments are described with reference to the following figures.

[0007] FIG. 1A depicts one embodiment of a cell expansion system (CES).

[0008] FIG. 1B depicts a second embodiment of a CES.

[0009] FIG. 1C depicts a third embodiment of a CES.

[0010] FIG. 2 illustrates a perspective view of a portion of a CES, including a detachably attached flow circuit, according to an embodiment.

[0011] FIG. 3A depicts a side view of an embodiment of a hollow fiber cell growth chamber.

[0012] FIG. 3B depicts a cut-away side view of the bioreactor shown in FIG. 3A.

[0013] FIG. 4 illustrates surface features of an uncoated surface of a hollow fiber that may be used in embodiments.

[0014] FIG. 5 illustrates surface features of a coated surface of a hollow fiber that may be used in embodiments.

[0015] FIG. 6 depicts an embodiment of a rocking device for moving a cell growth chamber rotationally or laterally during operation of a CES.

[0016] FIG. 7 illustrates an embodiment of a cell growth chamber (e.g., bioreactor) with a longitudinal axis LA-LA in an initial position.

[0017] FIG. 8 illustrates an embodiment of the cell growth chamber of FIG. 7 with the longitudinal axis LA-LA moved 90 degrees from the initial position.

[0018] FIG. 9 illustrates an embodiment of the cell growth chamber of FIG. 7 with the longitudinal axis LA-LA moved 180 degrees from the initial position.

[0019] FIG. 10 illustrates an embodiment of the cell growth chamber of FIG. 7 with the longitudinal axis LA-LA moved 270 degrees from the initial position.

[0020] FIG. 11 illustrates an embodiment of the cell growth chamber of FIG. 7 with the longitudinal axis LA-LA moved 270 degrees back to the initial position.

[0021] FIG. 12 illustrates a flow chart of a process for loading cells according to embodiments.

[0022] FIG. 13 illustrates a flow chart of a process for growing cells according to embodiments.

[0023] FIG. 14 illustrates fluid flow for movement of cells toward an inside wall of a hollow fiber.

[0024] FIG. 15 illustrates a cross-section of a hollow fiber showing cells in the hollow fiber before moving toward an inside wall of the hollow fiber according to embodiments.

[0025] FIG. 16 illustrates a cross-section of a hollow fiber showing cells in the hollow fiber moving toward an inside wall of the hollow fiber according to embodiments.

[0026] FIG. 17 illustrates a cross-section of a hollow fiber showing cells in the hollow fiber having moved toward an inside wall of the hollow fiber according to embodiments.

[0027] FIG. 18 illustrates a block diagram of a basic computer that may be used to implement embodiments.

[0028] FIG. 19 illustrates a graph of a shear stress model for a cell expansion system over a threshold for vascular endothelial growth factor receptor 2 (VEGFR2) induction.

[0029] FIG. 20 illustrates a graph of cell load v. doubling time.

[0030] FIGS. 21-23 illustrate glucose consumption and lactate generation graphs.

[0031] FIG. 24 illustrates a graph of relative quantification of VEGFR2 expression between two processes for growing endothelial cells.

Detailed Description

[0032] The principles of the present invention may be further understood by reference to the following detailed description and the embodiments depicted in the accompanying drawings. It should be understood that although specific features are shown and described below with respect to detailed embodiments, the present invention is not limited to the embodiments described below. It is noted that several embodiments are described with respect to loading or growing endothelial cells. However, the present invention is not limited to use with endothelial cells. Rather, the specific embodiments may be implemented with other cell types, some non-limiting examples including mesenchymal stem cells, fibroblasts, myoblasts, cardiomyocytes, etc.

[0033] Reference will now be made in detail to the embodiments illustrated in the accompanying drawings and described below. Wherever possible, the same reference numbers are used in the drawings and the description to refer to the same or like parts.

[0034] A schematic of an example cell expansion system (CES) 10 is depicted in FIG. 1A. CES 10 includes first fluid circulation path 12 and second fluid circulation path 14. First fluid flow path 16 has at least opposing ends 18 and 20 fluidly associated with a cell growth chamber 24 (also referred to herein as a "bioreactor"). Specifically, opposing end 18 may be fluidly associated with a first inlet 22 of cell growth chamber 24, and opposing end 20 may be fluidly associated with first outlet 28 of cell growth chamber 24. Fluid in first circulation path 12 may flow through the bioreactor. In those embodiments where the bioreactor is a hollow fiber bioreactor, the fluid may flow through the interior of hollow fiber of a hollow fiber membrane disposed in cell growth chamber 24 (hollow fiber membranes are described in more detail below). Further, first fluid flow controller 30 may be operably connected to first fluid flow path 16, and control the flow of fluid in first circulation path 12.

[0035] Second fluid circulation path 14 includes second fluid flow path 34, cell growth chamber 24, and a second fluid flow controller 32. The second fluid flow path 34 has at least opposing ends 36 and 38. Opposing ends 36 and 38 of second fluid flow path 34 are fluidly associated with inlet port 40 and outlet port 42 respectively of cell growth chamber 24. Fluid flowing through cell growth chamber 24, may, in embodiments, be in contact with the outside of a hollow fiber membrane in the cell growth chamber 24. Second fluid circulation path 14 may be operably connected to second fluid flow controller 32.

[0036] First and second fluid circulation paths 12 and 14 may in embodiments be separated in cell growth chamber 24 by a hollow fiber membrane. In these embodiments, fluid in first fluid circulation path 12 flows through the intracapillary (“IC”) space, including the interior, of the hollow fibers in the cell growth chamber 24. First circulation path 12 is thus referred to as the “IC loop.” Fluid in second fluid circulation path 14 flows through the extracapillary (“EC”) space in the cell growth chamber 24. Second fluid circulation path 14 is thus referred to as the “EC loop.” Fluid in first fluid circulation path 12 can flow in either a co-current or counter-current direction with respect to flow of fluid in second fluid circulation path 14. That is, fluid can flow clockwise or counter-clockwise in both the IC and EC loops, or they can flow in opposite directions.

[0037] Fluid inlet path 44 is fluidly associated with first fluid circulation path 12. Fluid inlet path 44 allows fluid to flow into first fluid circulation path 12, while fluid outlet path 46 allows fluid to leave CES 10. It is noted that in some embodiments a second fluid inlet path may be associated with second fluid circulation path 14 and a second outlet path may be associated with first fluid circulation path 12. Third fluid flow controller 48 is operably associated with fluid inlet path 44. A fourth fluid flow controller (not shown) may be associated with fluid outlet path 46, in some embodiments.

[0038] Fluid flow controllers as used herein can be a pump, valve, clamp, or combinations thereof. Multiple pumps, valves, and clamps can be arranged in any combination. In various embodiments, the fluid flow controller is or includes a peristaltic pump. In further embodiments, fluid circulation paths, inlet ports, and outlet ports can be constructed of tubing of any material.

[0039] Various components may be referred to herein as “operably associated.” As used herein, “operably associated” refers to components that are linked together in operable fashion, and encompasses embodiments in which components are linked directly, as well as embodiments in which additional components are placed between the two linked components. “Operably associated” components can be “fluidly associated.” “Fluidly associated” refers to components that are linked together such that fluid can be transported between them. “Fluidly associated” encompasses embodiments in which additional components are disposed between the two fluidly associated components, as well as components that are directly connected. Fluidly associated components can include components that do not contact fluid, but contact other components to manipulate the system (e.g. a peristaltic pump that pumps fluids through flexible tubing by compressing the exterior of the tube).

[0040] Generally, any kind of fluid, including buffers, protein containing fluid, and cell-containing fluid can flow through the various circulations paths, inlet paths, and outlet paths. As used herein, “fluid,” “media,” and “fluid media” may refer to material (including liquids) being circulated through the various paths (e.g., inlet paths, circulation paths, outlet paths, etc.).

[0041] FIG. 1B depicts an example of a more detailed cell expansion system 200. CES 200 includes a first fluid circulation path 202 (also referred to as the “intracapillary loop” or “IC loop”) and second fluid circulation path 204 (also referred to as the “extracapillary loop” or “EC loop”). First fluid flow path 206 is fluidly associated with a cell growth chamber (e.g., bioreactor 201) through fluid circulation path 202. Fluid flows into bioreactor 201 through IC inlet port 201A, through hollow fibers in bioreactor 201, and exits via IC outlet port 201B. Pressure sensor 210 measures the pressure of media leaving bioreactor 201. In addition to pressure, sensor 210 may in embodiments also be a temperature sensor that detects the media pressure and temperature during operation. Media flows through IC circulation pump 212 which can be used to control the rate of media flow, e.g., circulation rate in the IC loop. IC circulation pump 212 may pump the fluid in a first direction (e.g., clockwise or counter-clockwise) or second direction opposite the first direction. Exit port 201B can be used as an inlet in the reverse direction. Media entering the IC loop 202 may enter through

valve 214. As those skilled in the art will appreciate, additional valves and/or other devices can be placed at various locations to isolate and/or measure characteristics of the media along portions of the fluid paths. Accordingly, it is to be understood that the schematic shown represents one possible configuration for various elements of the CES 200 and modifications to the schematic shown are within the scope of the one or more present embodiments.

[0042] With regard to the IC loop 202, samples of media can be obtained from sample coil 218 during operation. Media then returns to IC inlet port 201A to complete fluid circulation path 202. Cells grown/expanded in bioreactor 201 can be flushed out of bioreactor 201 into harvest bag 299 through valve 298 and line 297. Alternatively, when valve 298 is closed, the cells may be redistributed, e.g., circulated back, within bioreactor 201 for further growth or loading.

[0043] Fluid in second fluid circulation path 204 enters bioreactor 201 via EC inlet port 201C, and leaves bioreactor 201 via EC outlet port 201D. Media in the EC loop 204 is in contact with the outside of the hollow fibers in bioreactor 201, thereby allowing diffusion of small molecules into and out of the hollow fibers that may be within bioreactor 201.

[0044] Pressure/temperature sensor 224 disposed in the second fluid circulation path 204 and allows the pressure and temperature of media to be measured before the media enters the EC space of the bioreactor 201. Sensor 226 allows the pressure and temperature of media in the second fluid circulation path 204 to be measured after it leaves the cell growth chamber 201. With regard to the EC loop 204, samples of media can be obtained from sample port 230 or a sample coil during operation.

[0045] After leaving EC outlet port 201D of bioreactor 201, fluid in second fluid circulation path 204 passes through EC circulation pump 228 to gas transfer module 232. EC circulation pump 228 is also capable of being switched to pump the fluid in an opposite direction. Second fluid flow path 222 is fluidly associated with gas transfer module 232 via an inlet port 232A and an outlet port 232B of gas transfer module 232. In operation, fluid media flows into gas transfer module 232 via inlet port 232A, and exits gas transfer module 232 via outlet port 232B. Gas transfer module 232 adds oxygen to and removes bubbles

from media in the CES 200. In various embodiments, media in second fluid circulation path 204 is in equilibrium with gas entering gas transfer module 232. The gas transfer module 232 can be any appropriately sized device known in the art and useful for oxygenation or gas transfer. Air or gas flows into gas transfer module 232 via filter 240 and out of oxygenator or gas transfer device 232 through filter 238. Filters 238 and 240 reduce or prevent contamination of oxygenator 232 and associated media. Air or gas purged from the CES 200 during portions of a priming sequence can vent to the atmosphere via the gas transfer module 232.

[0046] In the configuration depicted for CES 200, fluid media in first fluid circulation path 202 and second fluid circulation path 204 flows through bioreactor 201 in the same direction (a co-current configuration). The CES 200 can also be configured to flow in a counter-current configuration.

[0047] In accordance with at least one embodiment, media, including cells (from a source such as a cell container, e.g. a bag) can be attached at attachment point 262, and fluid media from a media source can be attached at attachment point 246. The cells and media can be introduced into first fluid circulation path 202 via first fluid flow path 206. Attachment point 262 is fluidly associated with the first fluid flow path 206 via valve 264, and attachment point 246 is fluidly associated with the first fluid flow path 206 via valve 250. A reagent source may be fluidly connected to point 244 and be associated with fluid inlet path 242 via valve 248, or second fluid inlet path 274 via valves 248 and 272.

[0048] Air removal chamber (ARC) 256 is fluidly associated with first circulation path 202. The air removal chamber 256 may include one or more sensors including an upper sensor and lower sensor to detect air, a lack of fluid, and/or a gas/fluid interface, e.g., an air/fluid interface, at certain measuring positions within the air removal chamber 256. For example, ultrasonic sensors may be used near the bottom and/or near the top of the air removal chamber 256 to detect air, fluid, and/or an air/fluid interface at these locations. Embodiments provide for the use of numerous other types of sensors without departing from the spirit and scope of the present disclosure. For example, optical sensors may be used in accordance with embodiments of the present disclosure. Air or gas purged from the CES 200 during portions of the priming sequence or other protocols can vent to the

atmosphere out air valve 260 via line 258 that is fluidly associated with air removal chamber 256.

[0049] An EC media source may be attached to EC media attachment point 268 and a wash solution source may be attached to wash solution attachment point 266, to add EC media and/or wash solution to either the first and/or second fluid flow path. Attachment point 266 may be fluidly associated with valve 270 that is fluidly associated with first fluid circulation path 202 via valve 272 and path 242. Alternatively, attachment point 266 can be fluidly associated with second fluid circulation path 204 via second fluid inlet path 274 and EC inlet path 284 by opening valve 270 and closing valve 272. Likewise, attachment point 268 is fluidly associated with valve 276 that may be fluidly associated with first fluid circulation path 202 via first fluid inlet path 242 and valve 272. Alternatively, attachment point 268 may be fluidly associated with second fluid inlet path 274 by opening valve 276 and closing valve distribution 272.

[0050] In the IC loop 202, fluid may be initially advanced by the IC inlet pump 254. In the EC loop 204, fluid is initially advanced by the EC inlet pump 278. An air detector 280, such as an ultrasonic sensor, may also be associated with the EC inlet path 284.

[0051] In at least one embodiment, first and second fluid circulation paths 202 and 204 are connected to waste line 288. When valve 290 is opened, IC media can flow through waste line 288 and to waste bag 286. Likewise, when valve 292 is opened, EC media can flow to waste bag 286.

[0052] After cells have been grown in bioreactor 201, they may be harvested via cell harvest path 297. Cells from cell growth chamber 201 can be harvested by pumping the IC media containing the cells through cell harvest path 297, with valve 298 open, into cell harvest bag 299.

[0053] Various components of the CES 200 can be contained or housed within a machine or housing 295, such as cell expansion machine, wherein the machine maintains cells and media at a predetermined temperature. It is further noted that in embodiments, components of CES 200 may be combined with other CES's such as CES 10 (FIG. 1A) or CES

300 (FIG. 1C). In other embodiments, a CES may include fewer components than shown in FIGS. 1A-C and still be within the scope of the present disclosure.

[0054] FIG. 1C depicts another embodiment of a CES. CES 300 includes first fluid circulation path 302 (also referred to as the “intracapillary (IC) loop”) and second fluid circulation path 304 (also referred to as the “extracapillary loop” or “EC loop”).

[0055] First fluid flow path 306 is fluidly associated with cell growth chamber 308 through first fluid circulation path 302. Fluid may flow into cell growth chamber 308 through inlet port 310, (e.g., through hollow fibers) in cell growth chamber 308, and exit via outlet port 307. Pressure gauge 317 measures the pressure of media leaving cell growth chamber 308. Media may flow through valve 313 and pump 311, which can be used to control the rate of media flow in the IC loop 302. Samples of media can be obtained from sample port 305 or sample coil 309 during operation. Pressure/temperature gauge 315 disposed in first fluid circulation path 302 allows detection of media pressure and temperature during operation. Media then returns to inlet port 310 to complete fluid circulation path 302. Cells expanded in cell growth chamber 308 can be flushed out of cell growth chamber 308 or redistributed within hollow fibers for further growth.

[0056] Second fluid circulation path 304 includes second fluid flow path 312 that is fluidly associated with cell growth chamber 308 in a loop. Fluid in second fluid circulation path 304 may enter cell growth chamber 308 via inlet port 314, and leaves cell growth chamber 308 via outlet port 316. Media is in contact with the outside of the hollow fibers in the cell growth chamber 308, allowing diffusion of small molecules into and out of the hollow fibers.

[0057] Pressure/temperature gauge 319 disposed in the second circulation path 304 allows the pressure and temperature of media to be measured before the media enters the EC space of the cell growth chamber 308. Pressure gauge 321 allows the pressure of media in the second circulation path 304 to be measured after it leaves the cell growth chamber 308.

[0058] After leaving outlet port 316 of cell growth chamber 308, fluid in second fluid circulation path 304 passes through pump 320 and valve 322 to oxygenator 318. Second

fluid flow path 312 is fluidly associated with oxygenator 318 via oxygenator inlet port 324 and oxygenator outlet port 326. In operation, fluid media flows into oxygenator 318 via oxygenator inlet port 324, and exits oxygenator 318 via oxygenator outlet port 326.

[0059] Oxygenator 318 adds oxygen to media in the CES 300. In various embodiments, media in second fluid circulation path 304 is in equilibrium with gas entering oxygenator 318. The oxygenator can be any oxygenator known in the art. Gas flows into oxygenator 318 via filter 328 and out of oxygenator 318 through filter 330. Filters 328 and 330 reduce or prevent contamination of oxygenator 318 and associated media.

[0060] In the configuration depicted for CES 300, fluid media in first circulation path 302 and second circulation path 304 flow through cell growth chamber 308 in the same direction (a co-current configuration). Those of skill in the art will recognize that CES 300 can also be configured in a counter-current configuration. Those of skill in the art will recognize that the respective inlet and outlet ports can be disposed in the cell growth chamber 308 at any location.

[0061] Cells and fluid media can be introduced to fluid circulation path 302 via first fluid inlet path 332. Fluid container 334 and fluid container 336 are fluidly associated with first fluid inlet path 332 via valves 338 and 340 respectively. Likewise, cell container 342 is fluidly associated with first fluid circulation path 302 via valve 343. Cells and fluid may in some embodiments proceed through heat exchanger 344, pump 346, and into drip chamber 348 before entering path 302. In embodiments where cells from container 342 are passed through heat exchanger 344, an additional line (not shown) would be used to connect container 342 to heat exchanger 344. Drip chamber 348 is fluidly associated with first circulation path 302. Overflow from drip chamber 348 can flow out of drip chamber 348 from overflow line 350 via valve 352.

[0062] Additional fluid can be added to first or second fluid circulation paths 302 and 304 from fluid container 354 and fluid container 356. Fluid container 354 is fluidly associated with valve 358 which is fluidly associated with first fluid circulation path 302 via valve 364, path 360, and path 332. Alternatively, fluid container 354 is fluidly associated with second fluid inlet path 362. Likewise, fluid container 356 is fluidly associated with valve

366, which is fluidly associated with first fluid circulation path 302 via first fluid inlet path 360. Alternatively, fluid container 356 is fluidly associated with second fluid inlet path 362.

[0063] Second fluid inlet path 362 is configured to allow fluid to flow through heat exchanger 344, pump 368, before entering drip chamber 370. Second fluid inlet path 362 continues to second fluid circulation path 304. Overflow fluid from second fluid circulation path 304 can flow out via overflow line 372 through valve 374 to waste container 376.

[0064] Cells can be harvested via cell harvest path 378. Cells from cell growth chamber 308 can be harvested by pumping media containing the cells through cell harvest path 378 to cell harvest bag 380, when valve 382 is opened.

[0065] First and second fluid circulation paths 302 and 304 are connected by connector path 384. When valve 386 is opened, media can flow through connector path 384 between first and second circulation paths 302 and 304. Likewise, pump 390 can pump media through another connector path 388 between first and second fluid circulation paths 302 and 304.

[0066] Various components of the CES 300 can be contained within incubator 399. Incubator 399 may maintain cells and media at a constant temperature.

[0067] As will be recognized by those of skill in the art, any number of fluid containers (e.g. media bags) can be fluidly associated with the CES 300 in any combination. It will further be noted that the location of the drip chamber 348, or sensors independent of the drip chamber 348, can be at any location in the CES 300 before inlet port 310.

[0068] CES's 200 and 300 can include additional components. For example, one or more pump loops (not shown) can be added at the location of peristaltic pumps on a CES. The pump loops may be made of polyurethane (PU) (available as Tygothane C-210A)). Alternatively, a disposable cassette for organizing the tubing lines and which may also contain tubing loops for the peristaltic pumps may also be included as part of the disposable.

[0069] A detachable flow circuit (also referred to herein as a "detachable flow circuit") may also be provided in some embodiments. The detachable flow circuit may in

embodiments incorporate portions of a cell expansion system (e.g., portions of CES 10, 200 and 300) and be configured to attach to more permanent fixed portions of the CES (e.g., other portions of CES 10, 200 and 300). The fixed portions of the CES may include peristaltic pumps. In various embodiments, the fixed portions of the CES can include valves and/or clamps.

[0070] The detachable flow circuit can include a first fluid flow path having at least two ends. The first end may be configured to be fluidly associated with a first end of a cell growth chamber, and a second end of the first fluid flow path configured to fluidly associated with a second end of the cell growth chamber (see, e.g., paths 12, 202, and 302).

[0071] Likewise, the detachable flow circuit can include a second fluid flow path having at least two ends. Portions of the detachable flow circuit can be configured to be fluidly associated with an oxygenator and/or bioreactor. The detachable flow circuit can include a second fluid flow path that may be configured to fluidly associate with the oxygenator and cell growth chamber (see, e.g., paths 14, 204, and 304).

[0072] In various embodiments, the detachable flow circuit may be detachably and disposably mounted to a fluid flow controller. The detachable flow circuit can include detachable fluid conduits (e.g. flexible tubing) that connect portions of the CES.

[0073] In further embodiments, the detachable flow circuit can include a cell growth chamber, oxygenator, as well as bags for containing media and cells. In various embodiments, the components can be connected together, or separate. Alternatively, detachable flow circuit can include one or more portions configured to attach to fluid flow controllers, such as valves, pumps, and combinations thereof. In variations where peristaltic pumps are used, the detachable circuit module can include a peristaltic loop configured to fit around a peristaltic portion of the tubing. In various embodiments, the peristaltic loop can be configured to be fluidly associated with the circulations paths, inlet paths, and outlet paths. The detachable flow circuit can be combined in a kit with instructions for its assembly or attachments to fluid flow controllers, such as pumps and valves.

[0074] Embodiments provide for using a number of different methods to introduce cells into bioreactors of CES. As described in greater detail below, embodiments include

methods and systems that distribute cells in the bioreactor to promote consistent expansion of cells.

[0075] According to embodiments, cells can be grown (“expanded”) in either the IC loop or the EC loop. Adherent and non-adherent suspension cells can be expanded. In one embodiment, the lumen of the cell growth chamber fibers can be coated with fibronectin. Divalent cation-free (e.g. calcium and magnesium-free) PBS may be added to a CES system for example. After adherent cells are introduced into a cell growth chamber, e.g., chamber 24, 201, or 308 they may be incubated for a sufficient time to adhere to the hollow fibers. IC and EC media may be circulated to ensure sufficient nutrients are supplied to the cells to allow them to grow.

[0076] The flow rate of the IC loop and EC loop can be adjusted to a specific value. In various embodiments, the flow rate of the IC loop and EC loops can be, independently set to, about 2, about 4, about 6, about 8, about 10, about 15, about 20, about 25, about 30, about 35, about 40, about 45, about 50, about 60, about 70, about 80, about 90, about 100, about 200, about 300, about 400 or even about 500 mL/minute. In various embodiments, the flow rates for the IC circuit loop may be set from about 10 to about 20 mL/minute, and the flow rate of the EC circuit loop may be set from 20 to about 30 mL per minute (allowing media to flow through an oxygenator and re-establish oxygen levels). Additional media may be pumped into the CES at a lower flow rate (e.g. 0.1 mL per minute in some embodiments) to replace media that evaporates through a gas exchange module(s) such as gas exchange/oxygenators 232 and 218. In various embodiments, the EC loop removes cellular waste, and the IC loop includes growth factors in the media.

[0077] CES’s may provide a great deal of flexibility in varying growth conditions and criteria. Cells can be kept in suspension in the IC loop by circulating media continuously. Alternatively, media circulation can be stopped, causing cells to settle. Fresh media can be added to the IC loop by ultrafiltration to accommodate excess volume without removing cells. EC media circulation allows for exchange of gas, nutrients, waste products, and addition of new media without removing cells.

[0078] Expanded cells can include adherent cells, non-adherent cells, or a co-culture of any combination of cells. Some non-limiting examples of cells that maybe grown in embodiments of a CES, include, without limitation, stem cells (e.g., mesenchymal, hematopoietic, etc.), fibroblasts, keratinocytes, progenitor cells, endothelial cells, cardiomyocytes, other fully differentiated cells, and combinations thereof.

[0079] In embodiments, to harvest adherent cells, the IC and EC media may be replaced with media that is free of divalent cations (e.g. divalent cation-free PBS). In one embodiment, trypsin may be loaded into a first circulation path, and allowed to incubate with adherent cells for a period of time (in some embodiments about 5 to about 10 minutes). The trypsin may then be flushed from the system. A shearing force may be applied to the cells by increasing the flow rate through cell growth chamber, and adherent cells that are released from the cell growth chamber may be pumped to a cell harvest bag.

[0080] When non-adherent cells are expanded, the cells can be flushed from the circulating IC circuit. Adherent cells remain in the cell growth chamber, while non-adherent cells are removed.

[0081] The CES can be used to perform a variety of cell expansion methods. In one embodiment, a seeded population of cells can be expanded. Cells are introduced, or seeded, into the CES. In certain circumstances, the lumen of the hollow fibers can be conditioned to allow cell adhesion. Cells are then added to the cell growth chamber, and adherent cells adhere to the hollow fibers, while non-adherent cells (e.g. hematopoietic stem cells, or HSCs) do not adhere. The non-adherent cells can be flushed from the system. After incubation for a period of time, the adherent cells can be released and harvested.

[0082] The cell growth chamber of the cell expansion system in embodiments includes a hollow fiber membrane comprised of a plurality of semi-permeable hollow fibers separating first and second fluid circulation paths. Embodiments of hollow fibers, hollow fiber membranes, and bioreactors are described below in greater detail.

[0083] Referring now to FIG. 2, a portion of an embodiment of a CES 400 is shown in perspective view. CES 400 includes both a detachable flow circuit 404 that may be disposable (in embodiments) and a permanent portion 408. The permanent portion 408

includes a back 412. For clarity, the front (or door) of the permanent portion 408 is not shown; however, the front may be attached to the back 412, such as by hinges 417, thereby allowing the front to comprise a door or hatch that can be opened to access the detachable flow circuit, which include a bioreactor 416. Attached to the bioreactor 416 may be a spool 420 for tubing and a sampling port 424.

[0084] As shown in FIG. 2, bioreactor 416 includes a first inlet port 428, a first outlet port 432, a second inlet port 438, and a second outlet port 442. In embodiments, first inlet port 428 and first outlet port 432 may be part of an IC circulation loop (e.g. 12, 202, and/or 302). Second inlet port 438 and second outlet port 442 may be part of an EC circulation loop (e.g. 14, 204, and/or 304)

[0085] In embodiments, CES 400 may control the temperature of detachable flow circuit 404. The detachable flow circuit 404 and its components may be connected to permanent portion 408 and the front closed to enclose the detachable flow circuit 404. Permanent portion 408 may then include heating elements, cooling elements, etc. to control the temperature inside permanent portion 408 to a desired temperature for growing cells in bioreactor 416 of detachable flow circuit 404.

[0086] Referring now to FIG. 3A and 3B, embodiments of a cell growth chamber 500 are depicted in FIGS. 3A and 3B, which may be referred to as a “bioreactor.” FIG. 3B depicts a cut-away and side view of a hollow fiber cell growth chamber 500. Cell growth chamber 500 is bounded by cell growth chamber housing 504. Cell growth chamber housing 504 further includes four openings, or ports: inlet port 508, outlet port 512, inlet port 516, and outlet port 520. In addition, chamber 500 has a longitudinal axis LA-LA as shown in FIG. 3B. Longitudinal axis LA-LA is generally parallel to a length dimension “L” of cell growth chamber 500. Longitudinal axis LA-LA is generally perpendicular to a height dimension “H” of cell growth chamber 500.

[0087] Fluid in the first circulation path may enter cell growth chamber 500 through inlet port 508, pass into and through the intracapillary side of a plurality of hollow fibers 524 (referred to in various embodiments as the intracapillary (“IC”) side or “IC space” of a hollow fiber membrane), and out of cell growth chamber 500 through outlet port 512. The terms

“hollow fiber,” “hollow fiber capillary,” and “capillary” may be used interchangeably. A plurality of hollow fibers 524 are collectively referred to as a “membrane.” Fluid in the second circulation path flows in the cell growth chamber through inlet port 516, comes in contact with the outside of the hollow fibers 524 (referred to as the “EC side” or “EC space” of the membrane), and exits cell growth chamber 500 via outlet port 520. Cells can be contained within the first circulation path or second circulation path, and can be on either the IC side or EC side of the membrane.

[0088] Although cell growth chamber housing 504 is depicted as cylindrical in shape, it can have other shapes, in other embodiments. Cell growth chamber housing 504 can be made of any type of biocompatible polymeric material. Various other cell growth chamber housings may differ in shape and size.

[0089] Those of skill in the art will recognize that the term cell growth chamber does not imply that all cells being grown or expanded in a CES are grown in the cell growth chamber. In many embodiments, adherent cells can adhere to membranes disposed in the growth chamber, or may grow within the associated tubing. Non-adherent cells (also referred to as “suspension cells”) can also be grown. Cells can be grown in other areas within the first or second fluid circulation path.

[0090] For example, the ends of hollow fibers 524 can be potted to the sides of the cell growth chamber 500 by a connective material (also referred to herein as “potting” or “potting material”). The potting can be any suitable material for binding the hollow fibers 524, provided that the flow of media and cells into the hollow fibers is not obstructed and that fluid (e.g., liquid) flowing into the cell growth chamber 500 through the IC inlet port flows only into the hollow fibers 524. An exemplary potting material includes, but is not limited to polyurethane. Other suitable binding or adhesive components may also be used in embodiments. In various embodiments, the hollow fibers 524 and potting may be cut through perpendicular to a central axis of the hollow fibers 524 at each end to permit fluid flow into and out of the IC side. End caps 528 and 532 may be disposed at the ends of the cell growth chamber.

[0091] Fluid entering cell growth chamber 500 via inlet port 516 is in contact with the outside of hollow fibers 524. This portion of the hollow fiber cell growth chamber is referred to as the “extracapillary (EC) space.” Small molecules (e.g. water, oxygen, lactate, etc.) can diffuse through the hollow fibers 524 from the interior of the hollow fiber to the EC space, or from the EC space to the IC space. Large molecular weight molecules such as growth factors are typically too large to pass through the hollow fibers 524, and remain in the IC space of the hollow fibers. In embodiments in which cells are grown in the IC space, the EC space is used as a medium reservoir to supply nutrients to the cells and remove the byproducts of cellular metabolism. The media may be replaced as needed. Media may also be circulated through an oxygenator to exchange gasses as needed.

[0092] In various embodiments, cells can be loaded into the hollow fibers 524 by any of a variety of methods, including by syringe. The cells may also be introduced into the cell growth chamber 500 from a fluid container, such as a bag, which may be fluidly associated with the cell growth chamber. Some specific examples of method for loading cells into bioreactor/hollow fibers are discussed below (see, e.g., FIG. 12).

[0093] Hollow fibers 524 may in embodiments allow cells to grow in the intracapillary space (i.e. inside the hollow fiber lumen) of the fibers. Hollow fibers 524 may be large enough to allow cell adhesion in the lumen without substantially impeding the flow of media through the hollow fiber lumen. In embodiments, the inner diameter of the hollow fiber can be greater than or equal to about 50 microns, about 100 microns, about 150 microns, about 200 microns, about 250 microns, about 300 microns, about 350 microns, about 400 microns, about 450 microns, about 500 microns, about 550 microns, about 600 microns, about 650 microns, about 700 microns, about 750 microns, about 800 microns, about 850 microns, about 900 microns, about 1000 microns, about 1100 microns, about 1200 microns, about 1300 microns, about 1400 microns, about 1500 microns, about 1600 microns, about 1700 microns , about 1800 microns, about 1900 microns, about 2000 microns, about 3000 microns, about 4000 microns, about 5000 microns, about 6000 microns, about 7000 microns, about 8000 microns, about 9000 microns, or even greater than or equal to about 10000 microns.

[0094] Likewise, in embodiments, the outer diameter of the hollow fibers 524 can be less than or equal to about 10000 microns, about 9000 microns, about 8000 microns, about 7000 microns, about 6000 microns, about 5000 microns, about 4000 microns, about 3000 microns, about 2000 microns, about 1000 microns, about 900 microns, about 800 microns, about 700 microns, about 650 microns, about 700 microns, about 650 microns, about 600 microns, about 550 microns, about 500 microns, about 450 microns, about 400 microns, about 350 microns, about 300 microns, about 250 microns, about 200 microns, about 150 microns, or even less than or equal to about 100 microns. The hollow fiber wall thickness may be sufficiently thin and have other characteristics (e.g., porous) to allow diffusion of small molecules.

[0095] Any number of hollow fibers can be used in a cell growth chamber according to embodiments, provided the hollow fibers can be fluidly associated with the inlet and outlet ports of the cell growth chamber. In embodiments, the cell growth chamber can include a number of hollow fibers greater than or equal to about 1000, about 2000, about 3000, about 4000, about 5000, about 6000, about 7000, about 8000, about 9000, about 10000, about 11000 or even greater than or equal to about 12000. In other embodiments, the cell growth chamber can include a number of hollow fibers less than or equal to about 15000, about 14000, about 13000, about 12000, about 11000, about 10000, about 9000, about 8000, about 7000, about 6000, about 5000, about 4000, about 3000, or even less than or equal to about 2000. In other various embodiments, the length of the hollow fibers can be greater than or equal to about 100 millimeters, about 200 millimeters, about 300 millimeters, about 400 millimeters, about 500 millimeters, about 600 millimeters, about 700 millimeters, about 800 millimeters, or even about 900 millimeters. In some embodiments, the cell growth chamber may include about 9000 hollow fibers that have an average length of about 295 millimeters, an average inner diameter of 215 microns, and an average outer diameter of about 315 microns.

[0096] Hollow fibers may be constructed of any material capable of forming a size sufficient to form fibers capable of transporting fluid (e.g., liquid) from the cell growth chamber inlet port to the cell growth chamber outlet port. In various embodiments, the hollow fibers can be constructed from plastic adherent materials capable of binding to

certain types of cells, such as adherent stem cells (e.g. MSCs) as one non-limiting example. In various other embodiments, hollow fibers can be treated with compounds such as fibronectin to form adherent surfaces.

[0097] In certain embodiments, the hollow fibers may be made of a semi-permeable, biocompatible polymeric material. One such polymeric material which can be used is a blend of polyamide, polyarylethersulfone and polyvinylpyrrolidone (referred to herein as "PA/PAES/PVP"). The semi-permeable membrane may allow transfer of nutrients, waste and dissolved gases through the membrane between the EC space and IC space. In various embodiments, the molecular transfer characteristics of the hollow fiber membranes may be chosen to minimize loss of expensive reagents necessary for cell growth such as growth factors, cytokines etc. from the hollow fiber, while allowing metabolic waste products to diffuse through the membrane into the hollow fiber lumen side to be removed.

[0098] In embodiments, one outer layer of each PA/PAES/PVP hollow fiber may be characterized by a homogenous and open pore structure with a defined surface roughness. The openings of the pores may be in the size range of about 0.5 to about 3 microns, and the number of pores on the outer surface of the fibers may be in the range of about 10,000 to about 150,000 pores per mm². This outer layer may have a thickness of from about 1 to about 10 microns. The next layer in each hollow fiber may be a second layer having the form of a sponge structure and, in embodiments may have a thickness of from about 1 to about 15 microns. This second layer may serve as a support for the outer layer. A third layer next to the second layer may have the form of finger-like structures. This third layer may provide mechanical stability and a high void volume which may give the membrane a low resistance to transporting molecules through the membrane. During use, the finger-like voids may be filled with fluid and the fluid may give a lower resistance for diffusion and convection than a matrix with a sponge-filled structure having a lower void volume. This third layer may have a thickness of about 20 to about 60 microns.

[0099] In further embodiments, the hollow fiber membrane can include between about 65 to about 95% by weight of at least one hydrophobic polymer and between about 5 to about 35% by weight of at least one hydrophilic polymer. The hydrophobic polymer may be chosen from the group consisting of polyamide (PA), polyaramide (PAA),

polyarylethersulphone (PAES), polyethersulphone (PES), polysulphone (PSU), polyarylsulphone (PASU), polycarbonate (PC), polyether, polyurethane (PUR), polyetherimide and copolymer mixtures of any of the above polymers, such as polyethersulphone or a mix of polyarylethersulphone and polyamide. In additional embodiments, the hydrophilic polymer may be chosen from the group consisting of polyvinylpyrrolidone (PVP), polyethylene glycol (PEG), polyglycolmonoester, water soluble cellulosic derivatives, polysorbate and polyethylene-polypropylene oxide copolymers.

[00100] In other embodiments, the fibers may have a combination of features that provide optimized conditions for growing a particular cell. As may be appreciated, some cell types may prefer particular structural features for optimum growth. In embodiments, hollow fibers may include features that optimize the growth of some cell types by providing a mechanical stimulus. Non-limiting examples of these cell types include endothelial cells and cardiomyocytes. For example, the hollow fibers may have a growth surface (i.e., interior surface) that has a radius of curvature that is greater than a dimension (e.g., diameter, length, etc.) of the cells. In embodiments, for use in growing endothelial cells, the hollow fibers may have an inner diameter less than about 300 microns, less than about 275 microns, less than about 250 microns, or even less than about 225 microns. In other embodiments, the hollow fibers may have an inner diameter greater than about 50 microns, about 100 microns, greater than about 150 microns, or even greater than about 200 microns. In other embodiments, for growing endothelial cells, the hollow fibers may have inner diameters that are between about 150 microns and about 250 microns, such as between about 160 microns and about 240 microns, between about 170 microns and about 230 microns, between about 180 microns and about 220 microns, or even between about 190 microns and about 210 microns.

[00101] In addition to inner diameter, growing of cells may be enhanced by providing an undulating, e.g., a surface with some texture. In some embodiments, the hollow fibers may include an interior surface that includes features that provide an uneven or undulating surface. For example, in some embodiments for growing endothelial cells, the interior surface of the hollow fiber may have features that provide some surface roughness. The features may generally extend parallel to a longitudinal axis of the hollow fiber. In other

embodiments, the features may extend perpendicular to the longitudinal axis of the hollow fiber. As a result of these features, the interior surface of the hollow fiber may have a surface roughness of between about 10 nanometers and about 100 nanometers, such as between about 20 nanometers and about 90 nanometers, between about 30 nanometers and about 80 nanometers, or even between about 40 nanometers and about 70 nanometers. In other embodiments for growing endothelial cells, the interior surface of the hollow fibers may have a surface roughness that is greater than about 10 nanometers, greater than about 15 nanometers, greater than about 20 nanometers, greater than about 25 nanometers, greater than about 30 nanometers, greater than about 35 nanometers, greater than about 40 nanometers, or even greater than about 45 nanometers. In other embodiments for growing endothelial cells, the interior surface of the hollow fibers may have a surface roughness that is less than about 150 nanometers, less than about 140 nanometers, less than about 130 nanometers, less than about 120 nanometers, less than about 110 nanometers, less than about 110 nanometers, less than about 90 nanometers, less than about 85 nanometers, less than about 80 nanometers, less than about 75 nanometers, less than about 70 nanometers, less than about 65 nanometers, less than about 60 nanometers, or even less than about 55 nanometers.

[00102] FIGS. 4 and 5 illustrate a representation of surface features (604, 704) on an inside surface (600, 700), e.g., lumen wall, of hollow fibers, according to embodiments. The features (604, 704) provide an undulating surface that, as indicated below, may promote the growth of some cells, e.g., endothelial cells. FIG. 4 illustrates an embodiment of an uncoated surface 600 from an interior of a hollow fiber and illustrates features 604. The features are elongated and undulating and create surface roughness. FIG. 5 illustrates an embodiment of an interior surface 700 of a hollow fiber coated with fibronectin 708. FIG. 5 illustrates features 704 similar to features 604. As illustrated in FIGS. 4 and 5, embodiments of hollow fibers provide features that create an undulating surface. Features 604 and 704 may in some embodiments extend along a length of the hollow fiber. In other embodiments, the features 604 and 708 may extend perpendicular, or at some other angle, with respect to a length dimension of the hollow fiber.

[00103] Further, depending upon the type of cells to be expanded, the hollow fibers may be treated with a substance, such as fibronectin 708, to enhance cell growth and/or adherence of the cells to the lumen wall. The substance can then be removed or deactivated in order to detach the cells from the surface of the hollow fiber.

[00104] It is noted that in some embodiments, a combination of structural features of a growth surface, e.g., hollow fiber, may enhance growth of certain cell types. For example, in some embodiments, the combination of a radial surface with a radius of curvature greater than an average cell dimension, such as a length or diameter (e.g., hollow fiber with inner diameter of about $215 \pm 10 \mu\text{m}$ in some embodiments) with an undulating 3D surface topography (e.g., $\pm 20\text{-}40 \text{ nm}$) in a hollow fiber membrane bioreactor may be used to advance cell priming and proliferation, e.g., endothelial cells. In addition, the other adherent cell types such as neural stem cells or mesenchymal stem cells may also be more efficiently (e.g., under optimized conditions) grown using the structural features described. These are merely some examples.

[00105] It is noted that the structural features described above (surface roughness and fiber inner diameter) for enhancing the growth of some cells is provided merely for illustrative purposes. In other embodiments, the hollow fiber diameter, surface roughness, or other structural features, may be changed depending on the cell type being expanded in the cell growth chamber to enhance growth of different cell types.

[00106] In addition to structural features, some embodiments provide for creating conditions in a CES controlled by fluid flow that optimizes growth of cells. As one example, a CES can include a device configured to move or “rock” a cell growth chamber relative to other components of the cell expansion system by attaching it to a rotational and/or lateral rocking device. FIG. 6 shows one such device, in which a bioreactor 800 is rotationally connected to two rotational rocking components, and a lateral rocking component.

[00107] A first rotational rocking device component 802 rotates the bioreactor 800 around longitudinal axis 810 of the bioreactor. Bioreactor 800 is also connected to lateral rocking device 804. Rotational rocking device component 802 is rotationally associated to bioreactor 800. The rotational rocking device 802 then rotates bioreactor 800 around

longitudinal axis 810 of the bioreactor. Rotation can occur in a clockwise or counterclockwise direction. Bioreactor 800 can be rotated continuously in a single direction around central axis 810 in a clockwise or counterclockwise direction. Alternatively, bioreactor 800 can rotate in alternating fashion, first clockwise, then counterclockwise around longitudinal axis 810.

[00108] The CES can also include a second rotational rocking component that rotates bioreactor 800 around rotational axis 812 so that longitudinal axis 810 is moved. Rotational axis 812 passes through the center of point of bioreactor 800 and is normal to longitudinal axis 810. Bioreactor 800 can be rotated continuously in a single direction around rotational axis 812 in a clockwise or counterclockwise direction. Alternatively, bioreactor 800 can be rotated around rotational axis 812 in an alternating fashion, first clockwise, then counterclockwise. In various embodiments, bioreactor 800 can also be rotated around rotational axis 812 and positioned in a horizontal or vertical orientation.

[00109] Lateral rocking component 804 is laterally associated with bioreactor 800. The plane of lateral rocking component 804 moves laterally in the $-x$ and $-y$ directions. The settling of cells in the bioreactor 800 is thereby reduced with the movement of cell-containing media within the hollow fibers.

[00110] The rotational and/or lateral movement of the rocking device can reduce the settling of cells within the device and reduce the likelihood of cells becoming trapped within a portion of the bioreactor 800. The rate of cells settling in the cell growth chamber (e.g., bioreactor 800) is proportional to the density difference between the cells and the suspension media according to Stoke's Law. In certain embodiments, a 180 degree rotation with a pause (e.g., having a total combined time of 30 seconds) repeated may keep non-adherent cells suspended. A minimum rotation of about 180 degrees may be performed in some embodiments; however, one could use rotation of up to 360 degrees or greater in other embodiments. Different rocking components can be used separately, or can be combined in any combination. For example, a rocking component that rotates bioreactor 800 around central axis 810 can be combined with the rocking component that rotates bioreactor 800 around axis 812. Likewise, clockwise and counterclockwise rotation around different axes can be performed independently in any combination.

[00111] It is noted that the rocking devices, and their components, described above, may be implemented in embodiments using any appropriate structure. For example, in embodiments, one or more motors may be used as rocking devices, or components (e.g. 802 and 804) of rocking devices. In one embodiment, the rocking devices may be implemented using embodiments shown and described in U.S. Patent No. 8,339,245 entitled ROTATION SYSTEM FOR CELL GROWTH CHAMBER OF A CELL EXPANSION SYSTEM AND METHOD OF USE THEREFOR, issued March 19, 2013, which is hereby incorporated by reference in its entirety as if set forth herein in full.

[00112] FIGS. 7-11 illustrate various positions of a bioreactor 900 according to embodiments. As described below, some embodiments provide for rotating a bioreactor during various steps. The steps may be performed as part of a process of loading cells into a bioreactor/CES, while in other embodiments; the steps may be performed as part of a process of growing or feeding cells that have been loaded into a bioreactor/CES. As described in greater detail below, in some embodiments, the rotation of the bioreactor from and to various positions may provide conditions (e.g., fluid flow) for creating conditions that enhance growth of some cell types, e.g., endothelial cells.

[00113] Referring to FIG. 7, and in accordance with at least one embodiment, the orientation of the bioreactor 900 is shown in a first position, which may be an initial starting position. As illustrated in FIG. 7, longitudinal axis LA-LA of the bioreactor 900 is substantially horizontal. FIG. 8 illustrates the bioreactor 100 in a second position, with LA-LA rotated 90 degrees from the position shown in FIG. 7. FIG. 9 illustrates the bioreactor 900 in a third position, with LA-LA rotated 180 degrees from the position shown in FIG. 7. FIG. 10 illustrates the bioreactor 900 in a fourth position, with LA-LA rotated 270 degrees from the position shown in FIG. 7. FIG. 11 illustrates bioreactor 900 after it is rotated back 270 degrees, with LA-LA back in the same position as shown in FIG. 7.

[00114] As described in greater detail below, rotation of a bioreactor may be performed in various processes to load, feed, and grow cells. The rotation may result in particular conditions that improve the growth of cell types in a CES. As one non-limiting example, a sequence of manipulations (e.g., rotations) may be undertaken to mitigate the influence of gravity on the cells when being loaded into the bioreactor 100. As another example, the

rotation may be used in creating a pulsatile effect that may mimic a heart beat that creates an improved environment for growing particular types of cells. Also, although in FIGS. 7-11 the bioreactor is described as initially starting with longitudinal axis LA-LA in a substantially horizontal position, in other embodiments, any of the positions (FIGS. 7-11) may be an initial position.

[00115] Referring now to FIGS. 12-14, flow charts are shown that depict one or more processes for loading and/or growing cells. Although features of a CES (e.g., CES 10, 200, and/or 300) may be described as performing some of the steps of the flow charts 1200 and/or 1300, the present invention is not limited thereto. Indeed, other CES's with different features, not described herein or described above (e.g., CES's 10, 200, or 300), may be utilized in some embodiments. Accordingly, reference to features of a CES such as bioreactors 24, 201, 308, 416, 500, and/or 800 are provided for illustrative purposes only, and the flow charts 1200 and/or 1300 are not limited to use with any specific CES. Furthermore, in embodiments steps may be performed by a processor or by a computer system such as system 1800 illustrated in FIG. 18.

[00116] Flow chart 1200 illustrates a process for loading cells into a CES with a hollow fiber bioreactor according to embodiments. Flow chart 1200 starts at 1204, and passes to step 1208 where an optional step may be performed to initially orient a bioreactor. For example, in embodiments where a disposable set is used with a CES (e.g., FIG. 2), when a disposable set is connected to the CES, the bioreactor may be initially oriented in a horizontal position (FIG. 7). As part of the first step 1208 of flow 1200, the bioreactor (e.g., bioreactor 24, 201, 308, 416, 500, 800) may in some embodiments be moved/positioned to orient it in a different position, e.g., vertical.

[00117] From optional step 1208 flow 1200 moves to step 1212 where a first fluid comprising cells is introduced into a bioreactor. In embodiments, the bioreactor may include a hollow fiber membrane with a plurality of hollow fibers. The first fluid may flow into the plurality of hollow fibers. In embodiments, step 1212 may involve introducing a first liquid with cells into a loop, e.g., IC loop and then circulated through the bioreactor. In embodiments, the hollow fiber membrane with the hollow fibers may be part of one of bioreactors 24, 201, 308, 416, 500, and 800, which includes a longitudinal axis.

[00118] In some embodiments, step 1212 may involve some optional sub-steps. For example, at sub-step 1216 the hollow fiber bioreactor may be rotated while the fluid with cells is circulated through the bioreactor. For example, in one embodiment, the bioreactor may be rotated between a first initial horizontal position (FIG. 7) through 270 degrees (FIG. 10) and then back to the first position (FIG. 11). This may be repeated for a predetermined period of time or until all of the cells have been introduced into a loop.

[00119] After step 1212, flow 1200 moves to step 1220 where the bioreactor is maintained in a first position. In some embodiments, the first position may be selected to achieve a particular result when cells are being attached to the inside of hollow fibers. For example, in embodiments, it may be desirable to keep as many cells in the hollow fibers as possible, and not allow the cells to attach to other areas of the loop outside of the hollow fibers. In these embodiments, it may be desirable to use gravity to assist in keep the cells in the hollow fibers by maintaining a longitudinal axis of the bioreactor at an angle (greater than zero degrees) from a first horizontal position (FIG. 7). Having the longitudinal axis at an angle from a horizontal position, may assist in keeping the cells in the hollow fibers even if fluid (e.g., liquid) is circulating through the hollow fibers. In one embodiment, the longitudinal axis is maintained at about 90 degrees from a horizontal position (FIG. 8).

[00120] From step 1220, flow moves to step 1224, where cells are moved toward a wall of the hollow fibers to be attached to an inside surface of the hollow fibers. In embodiments, the cells may be moved by introducing a second fluid (e.g., liquid) into the hollow fiber bioreactor. As described above, the hollow fibers may allow fluid (e.g., liquid) to pass through the fiber wall from an IC side to an EC side. In embodiments, step 1224 may provide for fluid (e.g., liquid) to pass through the fiber wall, which may result in the cells being pushed to an inside surface of the hollow fiber wall. In some embodiments, step 1224 may also involve modifying portions of a CES to ensure that fluid (e.g., liquid) is transferred across the fiber wall. For example, an IC loop valve (e.g., valves 290 or 386) may be closed so that the fluid (e.g., liquid) is transported across the fiber wall (e.g., from an IC space to an EC space). In some embodiments, the movement of fluid (e.g., liquid) thorough the fiber wall may be referred to as ultrafiltration.

[00121] Referring to FIGS. 14-17, an embodiment of performing steps 1220 and 1224 is illustrated. As shown in FIG. 14, a bioreactor 1400 (e.g., with a plurality of hollow fibers) is in a substantially vertical position as may be performed as part of step 1220 noted above. As may be appreciated, having bioreactor 1400 in the substantially vertical position means that gravity acts on cells in the bioreactor which may tend to keep the cells within the hollow fibers of the bioreactor instead of being pushed out of the hollow fibers into other parts of an IC loop.

[00122] FIGS. 15-17 illustrate a cross section of a hollow fiber 1500 according to an embodiment. FIG. 15 illustrates that cells are within the hollow fiber 1500. This may be the situation after step 1220 has been performed. FIG. 16 illustrates an example of the beginning of step 1224, where cells are being moved toward an interior surface 1508 of fiber wall 1504. As noted above, this may occur based on a second fluid (e.g., liquid) being introduced into the bioreactor (and consequently the hollow fibers) and then transported through fiber wall 1504. As shown in FIG. 16, cells have moved to surface 1508, which in this example includes a surface coating 1512. FIG. 16 illustrates that the cells begin to attach to surface 1508. FIG. 17 illustrates an example, after a predetermined period of time has passed, showing the cells having attached to the inside surface 1508.

[00123] It is noted that FIGS. 14-17 are provided merely to illustrate an example of how steps 1220 and 1224 may be performed, in some embodiments. It is noted that the present invention is not limited thereto. For example, although FIG. 17 may show all of the cells being attached to the surface 1508, in some embodiments only a portion of the cells may attach. As described below, some additional optional steps may be performed to attach a second portion (e.g., a portion remaining suspended in the fluid) of cells onto surface 1508.

[00124] Referring back to FIG. 12, after step 1224, an optional step 1228 may be performed to maintain a longitudinal axis of the hollow fiber bioreactor in a second position, which may aid in attaching cells to the inside surface of the hollow fibers. As one example, the hollow fiber bioreactor may be positioned in a horizontal position, see e.g., FIG. 7 and/or FIG. 9. This may allow gravity to settle cells that may remain suspended in the fluid after steps 1220 and 1224 to the inside surface of the hollow fiber. Optional step 1228 may be

followed by optional step 1232 where a second portion of cells may attach to an inside surface of the hollow fiber.

[00125] Flow 1200 passes from optional step 1232 to step 1236, where cells are expanded. That is, cells are grown to an amount that exceeds an original amount, e.g., doubled. In embodiments, step 1236 may involve a number of sub-steps. For example, step 1236 may involve introducing a fluid into the hollow fiber bioreactor to feed the cells. In other embodiments, step 1236 may further involve circulating a fluid through an EC space to remove waste and provide nutrient and gasses for the cells to grow as describe above with respect to FIGS 1A-1C. In some embodiments, step 1236 may involve one or more steps described below with respect to FIG. 13 and flow 1300. Flow 1200 ends at 1240.

[00126] Flow chart 1300 illustrates a process for growing cells in a CES with a hollow fiber bioreactor, according to embodiments. It is noted that in some embodiments flow 1300 may be used to expand particular types of cells that may respond to mechanical stimuli, such as endothelial cells or cardiomyocytes, as some non-limiting examples.

[00127] Flow chart 1300 starts at 1304, and passes to optional step 1308 where a bioreactor may be oriented. As noted above, in embodiments that provide for growing endothelial cells, the bioreactor may include a hollow fiber membrane with a number of hollow fibers each with particular structural characteristics that enhance or promote the expansion of some cells, endothelial cells. For example, the inner diameter and the surface roughness of the interior of the hollow fibers may be designed to optimize the growth of some cells.

[00128] Referring again to step 1308, in embodiments, where a disposable set is used with a CES (e.g., FIG. 4), when a disposable set is connected to the CES, the bioreactor (e.g., bioreactors 24, 201, 308, 416, 500, and/or 800) may be initially oriented in a horizontal position, accomplishing step 1308. In other embodiments, as part of step 1308 of flow 1300, the bioreactor may be moved/positioned to orient it at some angle from a horizontal position.

[00129] From optional step 1308 flow 1300 moves to step 1312 where a first fluid comprising cells is introduced into a hollow fiber bioreactor, e.g., into hollow fibers of the

bioreactor. In embodiments, step 1312 may involve introducing a first fluid (e.g., liquid) with the cells into a loop, e.g., IC loop and then circulated through the hollow fiber bioreactor. In embodiments, the hollow fiber bioreactor may be one of bioreactors 24, 201, 308, 416, 500, and 800, which includes a longitudinal axis.

[00130] Step 1312 is followed by step 1316 where cells are allowed to attach. In embodiments, steps 1308, 1312 and 1316 may be performed as part of a process of loading cells into a CES and bioreactor. For example, in some embodiments, flow 1200 may be performed to load cells into a bioreactor. In these embodiments, steps 1308, 1312 and 1316 may include performing one or more steps described above for flow 1200.

[00131] After step 1316, flow 1300 passes to step 1320 where cells loaded/attached to an inside surface of hollow fibers are expanded. In some embodiments, step 1320 includes a number of sub-steps that are performed to expand the cells. As one example, optional step 1324 may be performed to orient the bioreactor in a first position. In some embodiments, the first position may be a substantially vertical position (e.g., see FIG. 8).

[00132] After optional sub-step 1324, a fluid may be circulated through the bioreactor at a first rate to feed the cells and create shear stress on the cells in the bioreactor. The fluid may be media that includes protein, glucose, and/or other nutrients for cell growth. With respect to fluid shear stress, it is believed that having an environment where cells are subjected to shear stress may enhance the expansion of some cell types. As one example, endothelial cells may in some embodiments expand more readily if subjected to a threshold amount of fluid shear stress. That is, cells that multiply during expansion may express characteristic of receptors indicative of endothelial cells, e.g., expression of vascular endothelial growth factor receptor. The threshold amount of shear stress may in some embodiments be greater than or equal to 5 dyne/cm².

[00133] In other embodiments, the first rate may create fluid shear stress on the cells, but be less than the threshold amount. In some embodiments, as described in greater detail below, the conditions in the bioreactor may be controlled so as to create an environment for enhancing growth of a particular cell type, e.g., endothelial cells. In these embodiments, a combination of parameters (e.g., mechanical stimulus) may be controlled,

which in combination enhance the expansion of the cells. In some embodiments, any one parameter value may not result in enhanced expansion, but the combination results in enhanced cell expansion.

[00134] With respect to endothelial cells, a first flow rate used at step 1328 may result in shear stress less than the threshold, however in combination with hollow fibers with particular structural features (e.g., inner diameter size, undulating surface features) and/or other fluid conditions (e.g., pulsatile fluid flow), the flow rate may result in enough shear stress to provide enhanced expansion of cells, e.g., endothelial cells.

[00135] For example, the flow rate used at step 1328 may in embodiments result in shear stress on the cells that is greater than about 0.01 dyne/cm², greater than about 0.02 dyne/cm², greater than about 0.03 dyne/cm², greater than about 0.04 dyne/cm², greater than about 0.05 dyne/cm², greater than about 0.06 dyne/cm², greater than about 0.07 dyne/cm², greater than about 0.08 dyne/cm², greater than about 0.09 dyne/cm², greater than about 0.1 dyne/cm², greater than about 0.15 dyne/cm², greater than about 0.2 dyne/cm², greater than about 0.25 dyne/cm², greater than about 0.3 dyne/cm², greater than about 0.35 dyne/cm², greater than about 0.4 dyne/cm², greater than about 0.45 dyne/cm², greater than about 0.5 dyne/cm², greater than about 0.55 dyne/cm², greater than about 0.6 dyne/cm², greater than about 0.65 dyne/cm², greater than about 0.7 dyne/cm², or even greater than about 0.75 dyne/cm². In other embodiments, the flow rate selected at step 1328 may in embodiments result in shear stress on the cells that is less than about 5 dyne/cm², less than about 4 dyne/cm², less than about 3 dyne/cm², less than about 2 dyne/cm², less than about 1 dyne/cm², or even less than about 0.5 dyne/cm².

[00136] In embodiments, the first flow rate may be greater than about 0.5 ml/min, greater than about 1 ml/min, greater than about 1.5 ml/min, greater than about 2 ml/min, greater than about 2.5 ml/min, greater than about 3 ml/min, greater than about 3.5 ml/min, greater than about 4 ml/min, greater than about 4.5 ml/min, greater than about 5 ml/min, greater than about 10 ml/min, greater than about 15 ml/min, greater than about 20 ml/min, greater than about 25 ml/min, greater than about 30 ml/min, or even greater than about 35 ml/min. In other embodiments, the first flow rate may be less than about 400 ml/min, less than about 350 ml/min, less than about 300 ml/min, less than about 250 ml/min, less than

about 200 ml/min, less than about 150 ml/min, less than about 100 ml/min, or even less than about 50 ml/min.

[00137] In embodiments, the first flow rate may be between about 20 ml/min and about 100 ml/min, such as about 40 ml/min or about 50 ml/min. In this embodiment, the flow rate may subject the cells to a fluid sheer stress of between about 0.1 dyne/cm² and about 1 dyne/cm², such as about 0.5 dyne/cm² or about 0.7 dyne/cm².

[00138] In embodiments, steps 1324 and 1328 may be performed for a first predetermined period of time. That is, the bioreactor may be maintained in the first position and fluid circulated at the first fluid rate for a first predetermined period of time. In embodiments, the first predetermined period of time may be less than about 1500 minutes, less than about 1400 minutes, less than about 1300 minutes, less than about 1200 minutes, less than about 1100 minutes, less than about 1000 minutes, less than about 900 minutes, less than about 800 minutes, less than about 700 minutes, less than about 600 minutes, less than about 500 minutes, or even less than about 400 minutes. In other embodiments, the first predetermined period of time may be greater than about 50 minutes, greater than about 100 minutes, greater than about 150 minutes, greater than about 200 minutes, greater than about 250 minutes, greater than about 300 minutes, greater than about 350 minutes, or even greater than about 400 minutes. In one specific embodiment, the first predetermined period of time may be between about 100 minutes and about 500 minutes, such as about 480 minutes.

[00139] Referring again to flow 1300, after step 1328, optional step 1332 may be performed to maintain the bioreactor in a second position. As noted above, in embodiments, the first position may result in the longitudinal axis being substantially vertical (FIG. 8). Optional step 1332 may therefore involve rotating the bioreactor 90 degrees from the first position so that a longitudinal axis is substantially horizontal (FIG. 9).

[00140] From optional step 1332, flow may pass to optional step 1336 where fluid is circulated at a second rate, which may be lower than the first rate. As a result of being at a lower rate, step 1336 may involve subjecting the cells to a reduced level of fluid sheer stress. It is believed that changing the position of the bioreactor and changing the flow rate

may create a pulsatile fluid effect in the bioreactor, which may enhance the expansion of some cell types, e.g., endothelial cells. Without being bound by theory, it is believed that the pulsatile fluid effect may mimic the flow of blood in a living animal (e.g., a rate of a heartbeat).

[00141] In embodiments, the flow rate used at step 1336 may in embodiments result in shear stress on the cells that is less than about 3 dyne/cm², less than about 2 dyne/cm², less than about 1 dyne/cm², less than about 0.5 dyne/cm², less than about 0.25 dyne/cm², or even less than about 0.1 dyne/cm².

[00142] In embodiments, the second flow rate may be less than about 100 ml/min, less than about 50 ml/min, less than about 25 ml/min, less than about 10 ml/min, less than about 5 ml/min, less than about 2.5 ml/min, less than about 1.5 ml/min, or even less than about 1 ml/min.

[00143] In one specific embodiment, the second flow rate may be less than about 50 ml/min such as about 20 ml/min or about 0 ml/min. In this embodiment, the flow rate may subject the cells to a fluid shear stress of less than about 1 dyne/cm², such as about 0.1 dyne/cm² or about 0 dyne/cm².

[00144] In embodiments, steps 1332 and 1336 may be performed for a second predetermined period of time. That is, the bioreactor may be maintained in the second position and fluid circulated at the second fluid rate for a second predetermined period of time. In embodiments, the second predetermined period of time may be less than about 4000 minutes, less than about 3500 minutes, less than about 3000 minutes, less than about 2500 minutes, less than about 2000 minutes, less than about 1500 minutes, less than about 1400 minutes, less than about 1300 minutes, less than about 1200 minutes, less than about 1100 minutes, or even less than about 1000 minutes. In other embodiments, the second predetermined period of time may be greater than about 200 minutes, greater than about 300 minutes, greater than about 400 minutes, greater than about 500 minutes, greater than about 600 minutes, greater than about 700 minutes, greater than about 800 minutes, or even greater than about 900 minutes. In one specific embodiment, the second

predetermined period of time may be between about 800 minutes and about 1100 minutes, such as about 960 minutes.

[00145] After optional step 1336, optional step 1340 may be performed to maintain the bioreactor in a third position. As noted above, in embodiments, the second position may result in the longitudinal axis being substantially horizontal (FIG. 9). Optional step 1340 may therefore involve rotating the bioreactor 90 degrees from the second position (180 degrees from the first position) so that a longitudinal axis is substantially vertical (FIG. 10).

[00146] From optional step 1340, flow may pass to optional step 1344 where fluid is circulated at a third flow rate. It is noted that in some embodiments, the third flow rate may be the same as the first rate. In other embodiments, the third flow rate may be a different flow rate, such as any of the rates described above for the first flow rate and/or the second flow rate. By changing the position of the bioreactor and changing the flow rate back to the third flow rate, the pulsatile fluid effect may be continued in the bioreactor.

[00147] In embodiments, steps 1340 and 1344 may be performed for a third predetermined period of time. That is, the bioreactor may be maintained in the third position and fluid circulated at the third flow rate for a third predetermined period of time. In embodiments, the third predetermined period of time may be less than about 1500 minutes, less than about 1400 minutes, less than about 1300 minutes, less than about 1200 minutes, less than about 1100 minutes, less than about 1000 minutes, less than about 900 minutes, less than about 800 minutes, less than about 700 minutes, less than about 600 minutes, less than about 500 minutes, or even less than about 400 minutes. In other embodiments, the third predetermined period of time may be greater than about 50 minutes, greater than about 100 minutes, greater than about 150 minutes, greater than about 200 minutes, greater than about 250 minutes, greater than about 300 minutes, greater than about 350 minutes, or even greater than about 400 minutes. In one specific embodiment, the third predetermined period of time may be between about 100 minutes and about 500 minutes, such as about 480 minutes.

[00148] After optional step 1344, optional step 1348 may be performed to maintain the bioreactor in a fourth position. As noted above, in embodiments, the third position may

result in the longitudinal axis being substantially vertical (FIG. 10). Optional step 1348 may therefore involve rotating the bioreactor 90 degrees from the third position (270 degrees from the first position) so that a longitudinal axis is substantially horizontal (FIG. 11).

[00149] From optional step 1348, flow may pass to optional step 1352 where fluid is circulated at a fourth flow rate. It is noted that in some embodiments, the fourth flow rate may be the same as the second flow rate. In other embodiments, the fourth flow rate may be a different rate, such as any of the rates described above for the first flow rate and/or the second flow rate. By changing the position of the bioreactor and changing the flow rate back to the fourth flow rate, the pulsatile fluid effect may be continued in the bioreactor.

[00150] In embodiments, steps 1348 and 1352 may be performed for a fourth predetermined period of time. That is, the bioreactor may be maintained in the fourth position and fluid circulated at the fourth flow rate for a fourth predetermined period of time. In embodiments, the fourth predetermined period of time may be less than about 4000 minutes, less than about 3500 minutes, less than about 3000 minutes, less than about 2500 minutes, less than about 2000 minutes, less than about 1500 minutes, less than about 1400 minutes, less than about 1300 minutes, less than about 1200 minutes, less than about 1100 minutes, or even less than about 1000 minutes. In other embodiments, the fourth predetermined period of time may be greater than about 200 minutes, greater than about 300 minutes, greater than about 400 minutes, greater than about 500 minutes, greater than about 600 minutes, greater than about 700 minutes, greater than about 800 minutes, or even greater than about 900 minutes. In one specific embodiment, the fourth predetermined period of time may be between about 800 minutes and about 1100 minutes, such as about 960 minutes.

[00151] After optional step 1352, flow passes to step 1356 where the expanded cells are removed from the bioreactor. Step 1356 may, in embodiments, involve a number of sub-steps. For example, a harvest procedure may be performed as part of step 1356. The procedure may involve use of reagents (e.g., trypsin) to assist in detaching cells from an inside surface of hollow fibers. In some embodiments, flow of fluid through the IC loop and/or EC loop may be controlled to pass fluid from the EC loop to the IC loop to aid in

detaching cells and removing them from the bioreactor, e.g., negative ultrafiltration. After step 1356, flow 1300 ends at step 1360.

[00152] Although flow charts 1200 and 1300 (FIGS. 12 and 13) has been described with steps listed in a particular order, the present invention is not limited thereto. In other embodiments, steps may be performed in different order, in parallel, or any different number of times, e.g., before and after another step. Also, as indicated above, flow charts 1200 and 1300 may include some optional steps or sub-steps. However, those steps above that are not indicated as optional should not be considered as essential to the invention, but may be performed in some embodiments of the present invention and not in others.

[00153] FIG. 18 illustrates example components of a basic computer system 1800 upon which embodiments of the present invention may be implemented. Computer system 1800 may perform some steps in the methods for loading and distributing cells. System 1800 may be a controller for controlling features, e.g., flow control devices, pumps, valves, rotation of bioreactors, motors, etc., of CES systems 10, 430, 800, and 900 shown above in which cells are loaded and distributed for expansion.

[00154] Computer system 1800 includes output device(s) 1804, and/or input device(s) 1808. Output device(s) 1804 may include one or more displays, including CRT, LCD, and/or plasma displays. Output device(s) 1804 may also include a printer, speaker, etc. Input device(s) 1808 may include a keyboard, touch input devices, a mouse, voice input device, etc.

[00155] Basic computer system 1800 may also include a processing unit 1812 and/or a memory 1816, according to embodiments of the present invention. The processing unit 1812 may be a general purpose processor operable to execute instructions stored in memory 1816. Processing unit 1812 may include a single processor or multiple processors, according to embodiments. Further, in embodiments, each processor may be a multi-core processor having one or more cores to read and execute separate instructions. The processors may include general purpose processors, application specific integrated circuits (ASICs), field programmable gate arrays (FPGAs), other integrated circuits.

[00156] The memory 1816 may include any tangible medium for short-term or long-term storage for data and/or processor executable instructions, according to embodiments. The memory 1816 may include, for example, Random Access Memory (RAM), Read-Only Memory (ROM), or Electrically Erasable Programmable Read-Only Memory (EEPROM). Other storage media may include, for example, CD-ROM, tape, digital versatile disks (DVD) or other optical storage, tape, magnetic disk storage, magnetic tape, other magnetic storage devices, etc. In embodiments, system 1800 may be used to control the rotation of a bioreactor and/or various flow control devices, pumps, valves, etc. of CES systems. Memory 1816 can store protocols 1820 and procedures 1824, such as protocols and procedures for loading and expanding/feeding cells in a bioreactor, which would control operation of circulation pumps, valves, rotation of bioreactor(s), etc.

[00157] Storage 1828 may be any long-term data storage device or component. Storage 1820 may include one or more of the systems described in conjunction with memory 1816, according to embodiments. Storage 1828 may be permanent or removable. In embodiments, system 1800 is part of a CES system and storage 1828 may store various procedures for utilizing a CES system to load, distribute, attach, expand, and harvest cells of various types.

EXAMPLES

[00158] Described below are some examples of embodiments. However, it is noted that although specific protocols, cell types (e.g., endothelial cells) parameters, features, and/or values are described below, e.g., use of a CES, e.g., QUANTUM® cell expansion system, these are provided merely for illustrative purposes, and the present invention is not limited to the specific details provided below.

Example 1

[00159] Dynamic cell seeding of endothelial cells onto a fibronectin-coated hollow fiber membrane coupled with pulsatile, cyclic shear forces may serve to support the expansion of rat aorta endothelial cells (rAEC) to 4.0-5.4 cell doublings in less than 4 days with an automated system. Harvested cells may exhibit an elongated, cobblestone morphology. These data may suggest that the post-harvest rAEC phenotype may be characteristic of

actively proliferating endothelial cells. This automated expansion protocol may permit the use of cell seeding densities that are an order of magnitude below that generally employed in static rAEC culture.

[00160] Angiogenesis and the vascularization of tissue for regenerative medicine is a complex developmental process requiring a dependable supply of actively growing endothelial cells (EC). Typically, only 50% of arteriovenous grafts remain patent one year after surgery in hemodialysis patients with vascular access dysfunction. This highlights the medical necessity in neovascularization. Moreover, the 3-D architecture of the cell culture matrix as well as mechano-signal transduction play important roles in EC proliferation. In terms of surface topography, an undulating surface with a radius of curvature greater than the cell length has been shown to enhance bovine endothelial cell (BEC) proliferation. Specifically, it was demonstrated that patterned circular matrixes with diameters on the order of 200 μm support cytoskeletal mechanical stresses and BEC growth through BrdUrd incorporation and Rho kinase signaling. Fortunately, this micro-geometry can be translated into a biopharma production application through the use of hollow fiber bioreactors that are manufactured under controlled extrusion processes. The coordination of fluid shear stress from 5-15 dynes/cm² and VEGFR-2 expression are documented in the 2-D culture of human umbilical vein endothelial cells.

[00161] Consequently, modeling the intracapillary (IC) or lumen fluid shear stress over a range of flow rates, which generate a range of fluid shear stress (0–5 dynes•cm⁻²) in a 2.1 m² surface area hollow fiber membrane (HFM) bioreactor for the purposes of supporting rat endothelial cell proliferation in a cyclic mode of circulation may be useful.

[00162] FIG. 19 illustrates a graph showing an example of the relationship between fluid shear stress and a bioreactor IC flow rate with respect to VEGFR2 induction from discontinuous cell culture.

[00163] Hemodynamic forces, in the form of pulsatile blood flow, may serve to elicit homeostasis and remodeling functions from endothelial cells at or near the resting pulse rate (bpm) of the host organism. Therefore, an approach may be to combine the 3-D architecture of an HFM bioreactor matrix with dynamic seeding, fluid shear stress, and

undisturbed pulsatile flow to define a culture method for the expansion of rat aorta endothelial cells (rAECs) in the automated, functionally closed QUANTUM® cell expansion system (Terumo BCT).

[00164] The inoculum for the bioreactor may be prepared from adherent primary rat aorta endothelial cells (VEC Technologies) that may be grown to 80-90% confluency on hFibronectin-coated ($5 \mu\text{g} \cdot \text{cm}^{-2}$, BD 356008) TCPS flasks using MCDG-131-10 complete media (VEC Technologies) with 10% FBS (HyClone), antibiotics and glutamine at $37^{\circ}\text{C}/5\% \text{CO}_2$ under humidified conditions. The rAECs may subsequently be harvested with a sterile solution of Trypsin-EDTA 0.25% (Gibco 25200-056), counted with a Beckman Coulter Vi-CELL® XR Cell Viability Analyzer, resuspended in 100 mL of complete media, and seeded into the Quantum System hFibronectin-coated ($0.24 \mu\text{g} \cdot \text{cm}^{-2}$) HFM bioreactor using a dynamic cell loading procedure.

[00165] Cells may be expanded under laminar flow conditions with MCDG-131-10 complete media and mixed gas of $5\% \text{CO}_2/20\% \text{O}_2/75\% \text{N}_2$ at a temperature of 37°C . Glucose and lactate metabolite levels may be monitored throughout the culture process with Abbott i-STAT® analyzers and associated G and CG4+ cartridges. At the conclusion of the programmed expansion period, cells may be automatically harvested with 180 mL of sterile-filtered solution of Trypsin-EDTA 0.25%. Harvested samples may be counted, stained for membrane integrity (viability) with trypan blue, plated for morphology, analyzed for cell surface biomarker expression with a BD Canto II flow cytometer equipped using FACSDIVA software (v6.1.3), and evaluated for Dil acetylated-LDL internalization using a Zeiss Axio Observer A1 microscope equipped with Zen Pro software.

[00166] The Quantum System fluid circuit may be designed around two fluid loops: one loop for the intracapillary (IC) compartment of the bioreactor and the other for the extracapillary (EC) side of the system. Cells may be seeded to the IC compartment of the semi-permeable HFM bioreactor in order to control fluidic additions including inoculum, media, and supplements. In the EC compartment, gas exchange may be accomplished across the HFM and metabolite sampling may be achieved through the EC sampling port.

[00167] In order to seed the rAEC inoculum onto the HFM, the bioreactor may be oriented in an oscillating position (-90° to 180°) for dynamic cell seeding. This process may begin by introducing the 100 mL cell suspension into the intracapillary loop using an IC inlet flow rate of 25 mL/min with the transmembrane fluid outlet through the EC waste valve to retain the cells within fiber lumen of the bioreactor. The initial step may be followed by a 22 mL chase volume of complete media to load the cells into the bioreactor. Step 3 may introduce a 50 mL volume of complete media to transport the cells to HFM lumen wall with the bioreactor in the vertical (90°) position and the IC outlet valve open. The cell loading procedure may be completed by reorienting the bioreactor to an inverted stationary position at 180° for a 24-hour period with the IC outlet closed. This may allow cells that do not reach the HFM to have the opportunity to adhere to the lumen wall. Complete media may be subsequently added to and circulated through the extracapillary (EC) loop which contains the Gas Transfer Module (GTM) in order to maintain the gas mixture, buffer capacity, and volume of the system.

[00168] After the cell attachment phase, programmed media additions may be sequentially increased (0.1, 0.3, to 0.6 mL \cdot min $^{-1}$) to support the characteristic rAEC growth and motility by reorienting the bioreactor under continuous shear stress conditions over a 48-hour period. One purpose for this approach may be to enhance the distribution of junctional proteins such as VE-cadherin whose expression has been shown to increase in EC borders under laminar flow.

Table 1: Quantum System input for automated rAEC feeding, IC shear stress, and pulsatile rate. *Q = flow rate.

Bioreactor Orientation	Interval (min)	IC Inlet *Q (mL · min ⁻¹)	IC Circ *Q (mL · min ⁻¹)	IC Shear Stress (dynes · cm ⁻²)	Est. IC Circ Pulsatile Rate (bpm)	EC Inlet *Q (mL · min ⁻¹)	EC Circ *Q (mL · min ⁻¹)
90°	480	0.1-0.6	40-50	0.3	132-306	0	30
0°	960	0.1-0.6	20	0.6-0.7	66-122	0	30
270°	480	0.1-0.6	40-50	0.3	132-306	0	30
180°	960	0.1-0.6	20	0.6-0.7	66-122	0	30

[00169] At the conclusion of cell expansion (2.8-3.8 days), the rAECs may be released and harvested with an automated task that combines the exchange of PBS, circulation of Trypsin-EDTA (10 min), and introduction of complete media for enzymatic neutralization into a single process. Harvested cells may be centrifuged at 500xg for 7 min at ambient conditions, aspirated to remove supernatant debris, and resuspended in either complete media for analysis or in cryopreservation media (5% DMSO, 45% MCDB-131-10, 50% FBS), for storage in vapor phase liquid nitrogen.

[00170] Three (3) Quantum HFM hFibronectin-coated bioreactor runs may be seeded respectively with 3.36×10^7 , 1.40×10^7 , 3.36×10^7 rAECs in exponential growth phase using 100 mL of complete media (MCDB-131-10 w/10%FBS HyClone and Antibiotics) using the “Dynamic Cell Loading” task (see Example 2 below). The cells may be subsequently grown *ex vivo* for a period of 2.8-3.8 days using an automated 8-hour/16-hour cyclic fluid shear-stress feeding and harvesting protocol (see Example 3 below). Samples of the harvested cell suspension may be enumerated by Vi-CELL XR Cell Viability System, assayed for morphology, and analyzed for CD31⁺ CD45RA⁻ surface biomarker expression by flow cytometry. Representative cell samples may also be analyzed for the internalization of Dil acetylated-LDL by fluorescent microscopy.

Table 2: Summary of Possible Results of rAEC Expansion in the Quantum System.

Q-Run	Bioreactor Cell Seeding	rAEC Yield & Viability	Cell Culture Period, DS & DT	Bioreactor IC Circ Q & Max Shear Stress	Est. Max IC Pulsatile Rate (bpm)	rAEC Biomarker Phenotype	Dil Ac-LDL Internalization
Q1	3.36×10^7 $1,600 \cdot \text{cm}^{-2}$	1.47×10^9 98.9%	3.8 days DS 5.4 DT 16.7 hrs	0-40 mL · min ⁻¹ 0.6 dynes · cm ⁻²	40 mL · min ⁻¹ 132-245	CD31+ CD45RA-	Not Done
Q2	1.40×10^7 $667 \cdot \text{cm}^{-2}$	4.37×10^8 98.3%	2.8 days DS 5.0 DT 13.5 hrs	20-50 mL · min ⁻¹ 0.7 dynes · cm ⁻²	50 mL · min ⁻¹ 165-306	CD31+ CD45RA-	Positive
Q3	3.36×10^7 $1,600 \cdot \text{cm}^{-2}$	5.40×10^8 97.8%	2.8 days DS 4.0 DT 16.8 hrs	20-50 mL · min ⁻¹ 0.7 dynes · cm ⁻²	50 mL · min ⁻¹ 165-306	CD31+ CD45RA-	Positive

[00171] A comparison of the cell load and doubling time (DT) suggests that the rAEC seeding density of $667 \cdot \text{cm}^{-2}$ may generate a lower DT than the higher seeding density of $1,600 \cdot \text{cm}^{-2}$ particularly in the case of the Q2 and Q3 runs. This may be due, in part, to contact inhibitory effects of cells derived from a nearly confluent rAEC monolayer in the case of Q1 and Q3. FIG. 20 illustrates a graph showing cell load vs. doubling time for the three expansion runs described above.

[00172] FIGS. 21-23 illustrate glucose consumption and lactate generation graphs and show the metabolic profile of the rAEC growth over 2.8 to 3.8 days in the three runs described above. Glucose and lactate values may be collected daily with Abbott i-STAT® meters. The differences in the slope of these plots can be attributed to the range of seeding densities (667 - $1,600$ cells · cm^{-2}) and IC circulation rates that may be explored. Media IC input rates may be increased from 0.1, 0.3, 0.6 mL · min⁻¹ on a daily basis to maintain glucose levels on the order of 70 mg · dL⁻¹ and lactate levels at or below 5 mmol · L⁻¹.

[00173] FIG. 24 illustrate a graph showing the relative quantification of VEGFR2 expression comparing cells grown in a flask and cells grown in the Q3 run described above.

[00174] The exploration of microfluidics and their effects on endothelial cells have been performed in chambers with flat surfaces or in non-linear pathways with disruptive flow to study vascular dysfunction such as atherosclerosis and thrombosis. In contrast, laminar flow has been shown to enhance endothelial cell adhesion which is also dependent on cell seeding densities. For example, rAECs are typically seeded at densities of $3\text{-}4 \times 10^4$ cells \cdot cm^{-2} on flat TCPS surfaces (VEC Technologies). Alternatively, HFM bioreactors may be seeded with ECs at $6.67 \times 10^2 - 1.6 \times 10^3$ cells cm^{-2} utilizing a curved matrix. In feasibility experiments, a method may be defined to culture normal rAECs on a circular support with 3-D topographic features in an HFM bioreactor under continuous laminar flow conditions. The architecture of the HFM, with a radius of curvature greater than the cell length, has the potential to generate local mechanical stimuli that induce uniform endothelial cell proliferation. This proliferative effect can be further amplified with an undulating surface.

[00175] As a result, the study may suggest that dynamic cell seeding combined with cyclic shear stress culture, under continuous-pulsatile laminar flow, can support the efficient attachment and scale-up of endothelial cells for clinically relevant doses in a hollow fiber membrane bioreactor system. Moreover, the use of an automated control of pulsatile forces in an automated HFM system can potentially be extended to other cell types such as cardiomyocytes.

Example 2

[00176] Below are tables that provide non-limiting examples of a protocol (or portions of a protocol) that may be used when loading cells, e.g., endothelial cells according to embodiments. The example provides some values for settings that may be used in a CES, such as the QUANTUM cell expansion system to optimize the conditions for loading of some cell types, such as endothelial cells. The example is provided merely for illustrative purpose and other settings values may be used in other embodiments.

[00177] Furthermore, it is noted that in embodiments, the example below may be part of a larger protocol that includes other steps. For example, prior to loading cells in a CES/bioreactor, a protocol may include coating the bioreactor with a reagent to aid in the

attachment of cells. As another non-limiting example, a priming step for adding fluid (e.g., liquid) into a dry CES may also precede the loading and coating portions of a protocol.

[00178] The purpose of this protocol may be to enable adherent cells to attach to the bioreactor membrane while allowing flow on the EC circulation loop. The pump flow rate to the IC loop may be set to zero.

[00179] Prior to loading the cells into all of the Quantum systems with Distribution and Rotation, install a Custom Task using the following existing/modified steps: Config>Task via the touch screen display or GUI. These solutions and corresponding volumes are based on the default settings for this task.

Table 3: Solutions for Attach Cells, Modification

Table 3: Solutions for Attach Cells		
Bag	Solution in Bag	Volume (estimate based on factory values)
Cell Inlet	None	N/A
Reagent	None	N/A
IC Media	Media with FBS	6 mL/hour
Wash	None	N/A
EC Media	None	N/A

[00180] Enter and confirm the values for each setting for Step 1 shown in Table 4.

Table 4: Vertical Cell Load - Config>Task>Custom>Save Modified, Step 1

Table 4: Load Cells into IC Loop			
Setting	Factory	Laboratory	Modifications
IC Inlet	Cell		Cell
IC Inlet Rate	50		25 mL/min
IC Circulation Rate	139		0 mL/min
EC Inlet	None		None
EC Inlet Rate	0		0
EC Circulation Rate	30		30
Outlet	EC Waste		EC Waste
Rocker Control	In Motion (-90° to 180°)		In Motion (-90° to 180°)
Stop Condition	Empty Bag		Empty Bag
Estimated Fluid	Unknown		Unknown
Omit or Include	Include		Include

[00181] Enter and confirm the values for each setting for Step 2 shown in Table 5.

Table 5: Vertical ARC Chase - Config>Task>Custom>Save Modified, Step 2

Table 5: ARC Chase			
Setting	Factory	Laboratory	Modifications
IC Inlet	IC Media		IC Media
IC Inlet Rate	50		25 mL/min
IC Circulation Rate	139		0 mL/min
EC Inlet	None		None
EC Inlet Rate	0		0
EC Circulation Rate	30		30
Outlet	EC Waste		IC Waste
Rocker Control	In Motion (-90° to 180°)		In Motion (-90° to 180°)
Stop Condition	IC Volume (22 mL)		IC Volume (22 mL)
Estimated Fluid	0.1 L		0.1 L
Omit or Include	Include		Include

[00182] Enter and confirm the values for each setting for Step 3 shown in Table 6.

Table 6: Membrane Transport - Config>Task>Custom>Save Modified, Step 3

Table 6: Task Settings to Transport Cells to Bioreactor IC HFM			
Setting	Factory	Laboratory	Modifications
IC Inlet	None		IC Media
IC Inlet Rate	0		25 mL/min
IC Circulation Rate	0		0
EC Inlet	EC Media		None
EC Inlet Rate	0		0
EC Circulation Rate	0		30
Outlet	EC Waste		EC Waste
Rocker Control	Stationary (0°)		Stationary (90°)
Stop Condition	Manual		IC Volume (50 mL)
Estimated Fluid	Unknown		Unknown
Omit or Include	Include		Include

[00183] Enter and confirm the values for each setting for Step 4 shown in Table 7.

Table 7: Inverted Cell Attachment - Config>Task>Custom>Save Modified, Step 4

Table 7: Task Settings for Attach Cells in Bioreactor			
Setting	Factory	Laboratory	Modifications
IC Inlet	None		None
IC Inlet Rate	0		0
IC Circulation Rate	0		0
EC Inlet	EC Media	IC Media	None
EC Inlet Rate	0		0.1
EC Circulation Rate	0		30
Outlet	EC Waste		EC Waste
Rocker Control	Stationary (0°)		Stationary (180°)
Stop Condition	Manual		Time: 1,440 minutes
Estimated Fluid	Unknown		Unknown
Omit or Include	Include		Include

Example 3

[00184] Below are tables that provide a non-limiting example of a protocol that may be used when expanding/feeding cells, e.g., endothelial cells according to embodiments. The example provides some values for parameters that may be used in a CES, such as the QUANTUM cell expansion system to optimize the conditions for growing/feeding some cell

types, such as endothelial cells. The example is provided merely for illustrative purpose and other parameter values may be used in other embodiments.

[00185] Furthermore, it is noted that in embodiments, the examples below may be part of a larger protocol that includes other steps. For example, prior to expanding/feeding cells in a CES/bioreactor, a protocol may include coating the bioreactor with a reagent to aid in the attachment of cells. As another non-limiting example, loading cells (see, e.g., Example 2, above) into a bioreactor/CES may precede expanding/feeding of cells.

[00186] Continue with the modified pre-cultured hMSC expansion protocol for RAECs. To induce EC proliferation during growth phase of the expansion process, alternate the conditions within each 24-hour period between “Shear Stress” interval by using an IC Circ Q = 40 mL/min for 8 hours and “Rest” interval with an IC Circ Q = 0 mL/min for 16 hours as outlined in Tables 8-11. Repeat the following 48-hour feeding schedule during the growth phase of cell expansion and adjust IC Input per metabolite measurements.

[00187] Enter and confirm the values for each setting for Step 1 shown in Table 8.

Table 8: Vertical Feed Cells, Shear Stress 1 - Config>Task>Custom>Save, Modified, Step 1

Table 8: Task Settings for Attach Cells, Step 5 (Feed Cells on Day 2)			
Setting	Factory	Laboratory	Modifications
IC Inlet	IC Media		IC Media
IC Inlet Rate	0.1		0.1
IC Circulation Rate	20		40 mL/min
EC Inlet	EC Media	IC Media	None
EC Inlet Rate	0.1		0
EC Circulation Rate	30		30
Outlet	IC Waste		IC Waste
Rocker Control	Stationary (0°)		Stationary (90°)
Stop Condition	Manual		Time: 480 min
Estimated Fluid	Unknown		Unknown
Omit or Include	Include		Include

[00188] Enter and confirm the values for each setting for Step 2 shown in Table 9.

Table 9: Horizontal Feed Cells, Rest Phase 1 - Config>Task>Custom>Save, Modified, Step 2

Table 9: Task Settings for Attach Cells, Step 6 (Feed Cells on Day 2+)

Setting	Factory	Laboratory	Modifications
IC Inlet	IC Media		IC Media
IC Inlet Rate	0.1		0.1
IC Circulation Rate	20		0 mL/min
EC Inlet	EC Media	IC Media	None
EC Inlet Rate	0.1		0
EC Circulation Rate	30		30
Outlet	IC Waste		IC Waste
Rocker Control	Stationary (0°)		Stationary (90°)
Stop Condition	Manual		Time: 960 min
Estimated Fluid	Unknown		Unknown
Omit or Include	Include		Include

[00189] Enter and confirm the values for each setting for Step 3 shown in Table 10.

Table 10: Vertical Feed Cells, Shear Stress 2 - Config>Task>Custom>Save, Modified, Step 3

Table 10: Task Settings for Attach Cells, Step 7 (Feed Cells on Day 3+)

Setting	Factory	Laboratory	Modifications
IC Inlet	IC Media		IC Media
IC Inlet Rate	0.1		0.1
IC Circulation Rate	20		40 mL/min
EC Inlet	EC Media	IC Media	None
EC Inlet Rate	0.1		0
EC Circulation Rate	30		30
Outlet	IC Waste		IC Waste
Rocker Control	Stationary (0°)		Stationary (270°)
Stop Condition	Manual		Time: 480 min
Estimated Fluid	Unknown		Unknown
Omit or Include	Include		Include

[00190] Enter and confirm the values for each setting for Step 4 shown in Table 11.

Table 11: Horizontal Feed Cells, Rest Phase 2 - Config>Task>Custom>Save, Modified, Step 4

Table 11: Task Settings for Attach Cells, Step 8 (Feed Cells on Day3+)

Setting	Factory	Laboratory	Modifications
IC Inlet	IC Media		IC Media
IC Inlet Rate	0.1		0.1
IC Circulation Rate	20		0 mL/min
EC Inlet	EC Media	IC Media	None
EC Inlet Rate	0.1		0
EC Circulation Rate	30		30
Outlet	IC Waste		IC Waste
Rocker Control	Stationary (0°)		Stationary (180°)
Stop Condition	Manual		Time: 960 min
Estimated Fluid	Unknown		Unknown
Omit or Include	Include		Include

[00191] Program the IC Input Q based on the following schedule and adjust per glucose concentrations during the expansion process:

Day 2 = 0.1 mL/min

Day 3 = 0.3 mL/min

Day 4 = 0.6 mL/min

Day 5 = 1.2 mL/min

Day 6 = 1.6 mL/min

[00192] It may be apparent to those skilled in the art that various modifications and variations can be made to the embodiments of the present invention described above without departing from their scope. Thus it should be understood that the invention is not be limited to the specific examples given, the embodiments described, or the embodiments shown in the figures. Rather, the invention is intended to cover modifications and variations.

[00193] While example embodiments and applications of the present invention have been illustrated and described, it is to be understood that the invention is not limited to the precise configuration, steps, and structures described above. Various modifications,

changes, and variations apparent to those skilled in the art may be made in the arrangement, operation, and details of the methods and systems of the present invention disclosed herein without departing from the scope of the invention.

WHAT IS CLAIMED IS:

1. A method of loading cells in a hollow fiber bioreactor comprising a longitudinal axis, the method comprising:
 - introducing a first fluid comprising cells into a plurality of hollow fibers in the hollow fiber bioreactor;
 - maintaining the longitudinal axis of the hollow fiber bioreactor at an angle greater than zero degrees from a first position, wherein the longitudinal axis is substantially horizontal when in the first position; and
 - while maintaining the longitudinal axis of the hollow fiber bioreactor at the angle, moving the cells toward an inside wall of at least one of the plurality of hollow fibers by introducing a second fluid into the bioreactor, wherein a portion of the second fluid passes through a wall of the at least one of the plurality of hollow fibers and a portion of the cells attach to a lumen wall of the at least one of the plurality of hollow fibers.
2. The method of claim 1, wherein the plurality of hollow fibers are part of an intracapillary space of the bioreactor and wherein the portion of the second fluid passes from the intracapillary space to an extracapillary space of the bioreactor.
3. The method of claim 2, wherein an outlet of the intracapillary space is closed during the moving the cells.
4. The method of claim 1, wherein the angle of the longitudinal axis is about 90 degrees from the first position.
5. The method of claim 1, wherein during the introducing the first fluid, rotating the longitudinal axis about 270 degrees from an initial position and back to the initial position.
6. The method of claim 1, further comprising:

after the moving the cells, maintaining the longitudinal axis at about 180 degrees from the first position for a predetermined period of time to allow a second portion of cells to attach the at least one of the plurality of hollow fibers.

7. A method of growing cells in a hollow fiber bioreactor, the method comprising:
 - introducing a first fluid comprising cells into a plurality of hollow fibers in the hollow fiber bioreactor, wherein the hollow fiber bioreactor comprises a longitudinal axis;
 - allowing the cells to attach to an inside surface of at least one of the plurality of hollow fibers;
 - expanding the cells by circulating media in the bioreactor to feed the cells, wherein during the expanding the media is circulated at a first flow rate that subjects the cells to a fluid shear stress greater than about 0.01 dynes/cm² for a first predetermined period of time; and
 - removing the cells from the hollow fiber bioreactor.

8. The method of claim 7, wherein the expanding comprises:
 - maintaining the longitudinal axis of the bioreactor substantially in a first position while circulating the media in the bioreactor during the first predetermined period of time, wherein the first position is substantially vertical.

9. The method of claim 8, wherein the expanding further comprises:
 - maintaining the longitudinal axis at about 90 degrees from the first position while circulating the media in the bioreactor for a second predetermined period of time.

10. The method of claim 9, wherein during the second period of time, the media is circulated at a second flow rate, which is less than the first flow rate.

11. The method of claim 9, wherein the expanding further comprises:
 - maintaining the longitudinal axis at about 180 degrees from the first position while circulating the media in the bioreactor for a third predetermined period of time.

12. The method of claim 9, wherein during the third period of time, the media is circulated at the first flow rate.

13. The method of claim 11, wherein the expanding further comprises:
maintaining the longitudinal axis at about 270 degrees from the first position while circulating the media in the bioreactor for a fourth predetermined period of time.

14. The method of claim 13, wherein during the fourth period of time, the media is circulated at the second flow rate, which is less than the first flow rate.

15. The method of claim 7, wherein the flow rate is greater than about 1.5 ml/min.

16. The method of claim 7, wherein the flow rate is less than about 400 ml/min.

17. A method of growing endothelial cells, the method comprising:
introducing a plurality of endothelial cells into a hollow fiber bioreactor, the bioreactor comprising:

a hollow fiber membrane, wherein the hollow fiber membrane comprises a plurality of hollow fibers; and

wherein each of the hollow fibers comprise an inner diameter with a radius of curvature greater than a dimension of one of the plurality of endothelial cells, and wherein each of the hollow fibers has undulating features on an interior surface;

expanding the plurality of endothelial cells to generate a second plurality of cells greater than the first plurality of cells, wherein the expanding comprising circulating fluid through the hollow fiber membrane, the fluid circulating at a flow rate that subjects the plurality of endothelial cells to a fluid shear stress that induces expression of vascular endothelial growth factor receptors; and

removing the second plurality of cells from the bioreactor.

18. The hollow fiber bioreactor of claim 17, wherein the interior surface of the plurality of hollow fibers comprise a surface roughness of less than about 60 nanometers.

19. The method of 17, wherein an inner diameter of each of a portion of the plurality of hollow fibers is between about 175 microns and about 250 microns.

20. The method of claim 17, wherein the inner diameter of each of a portion of the plurality of hollow fibers is between about 200 microns and about 225 microns.

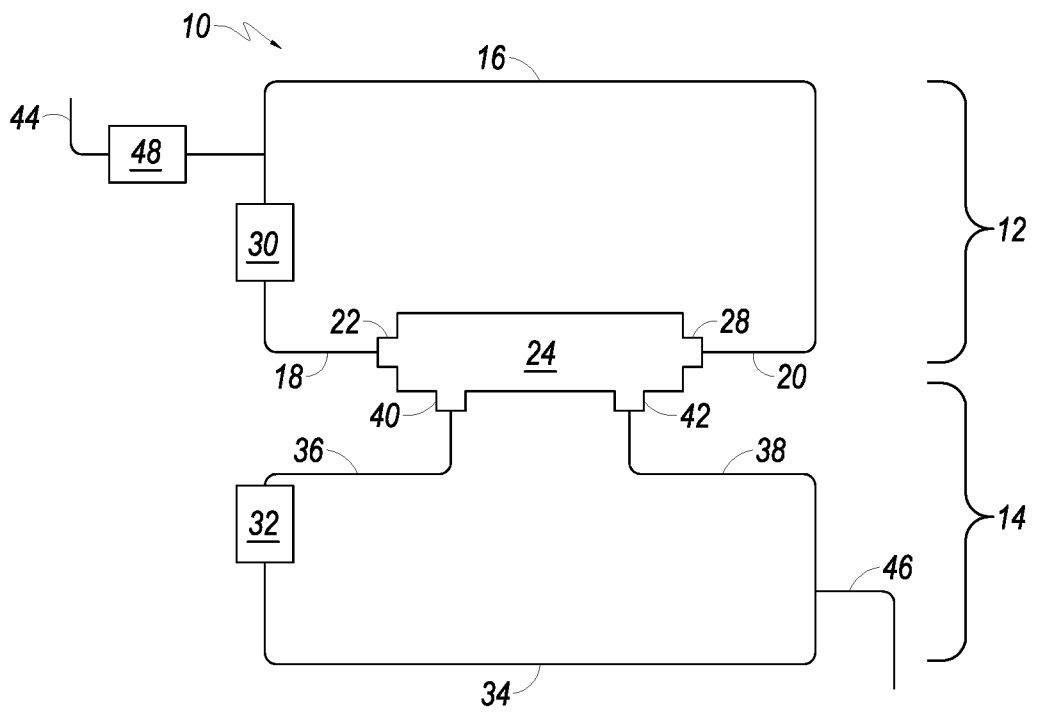

FIG. 1A

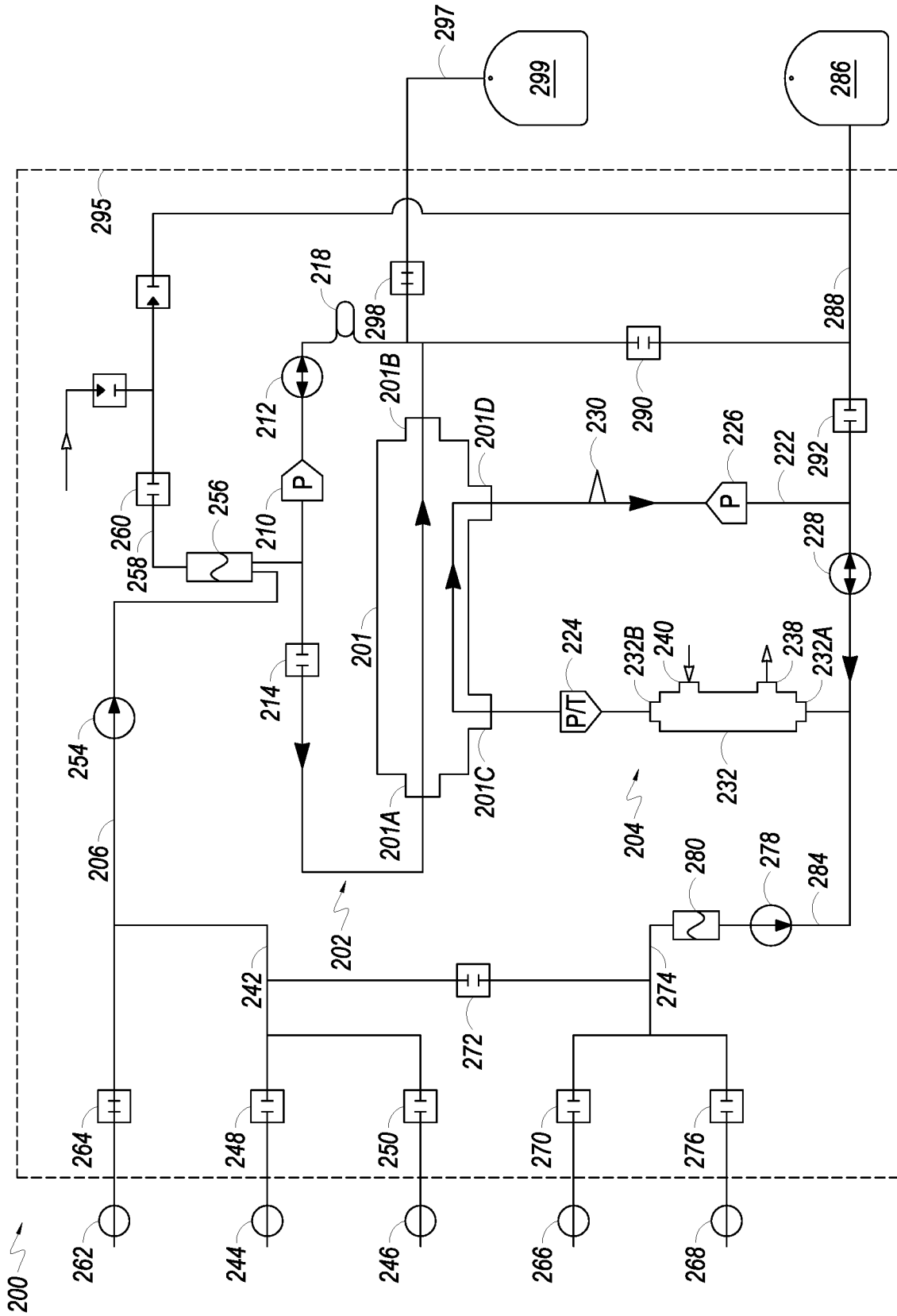

FIG. 1B

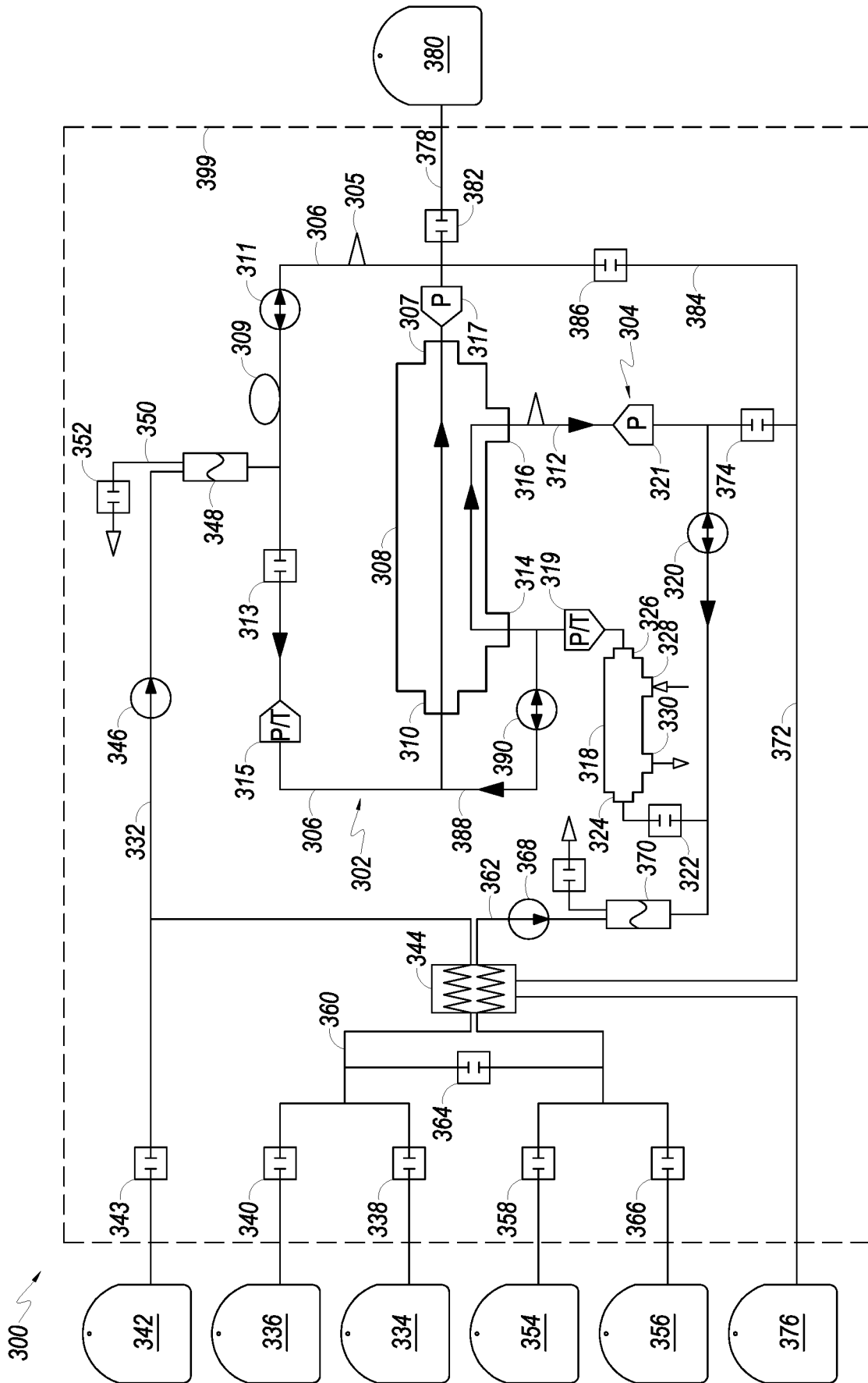

FIG. 1C

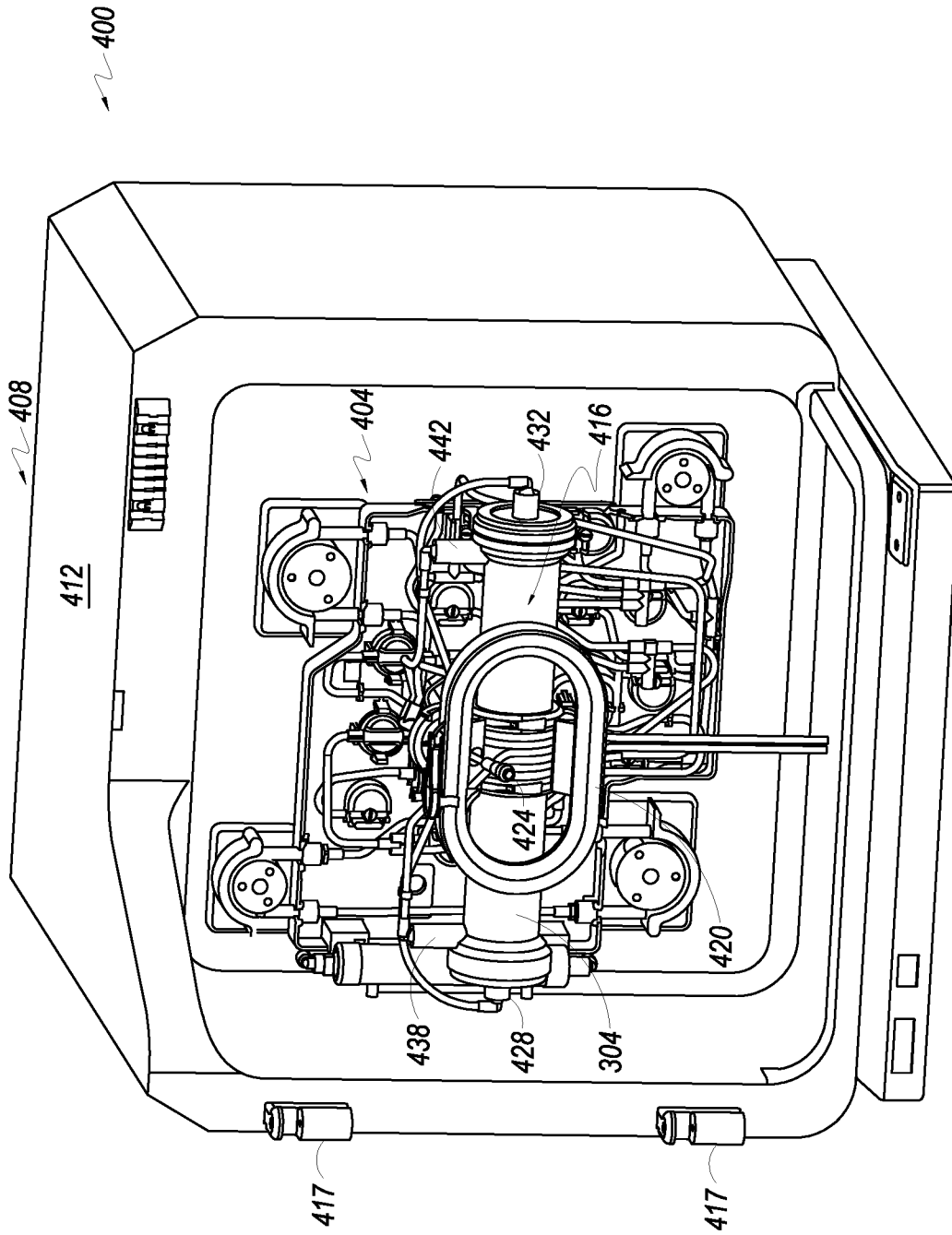

FIG. 2

5/19

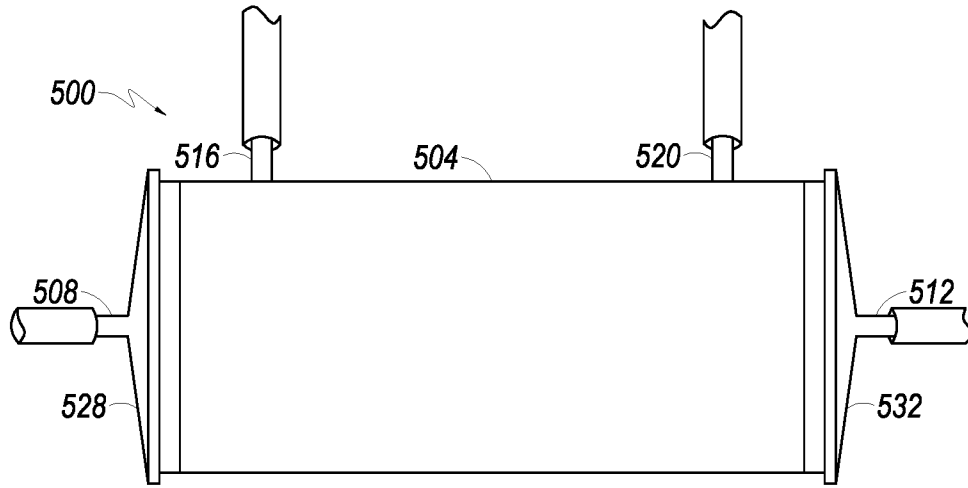

FIG. 3A

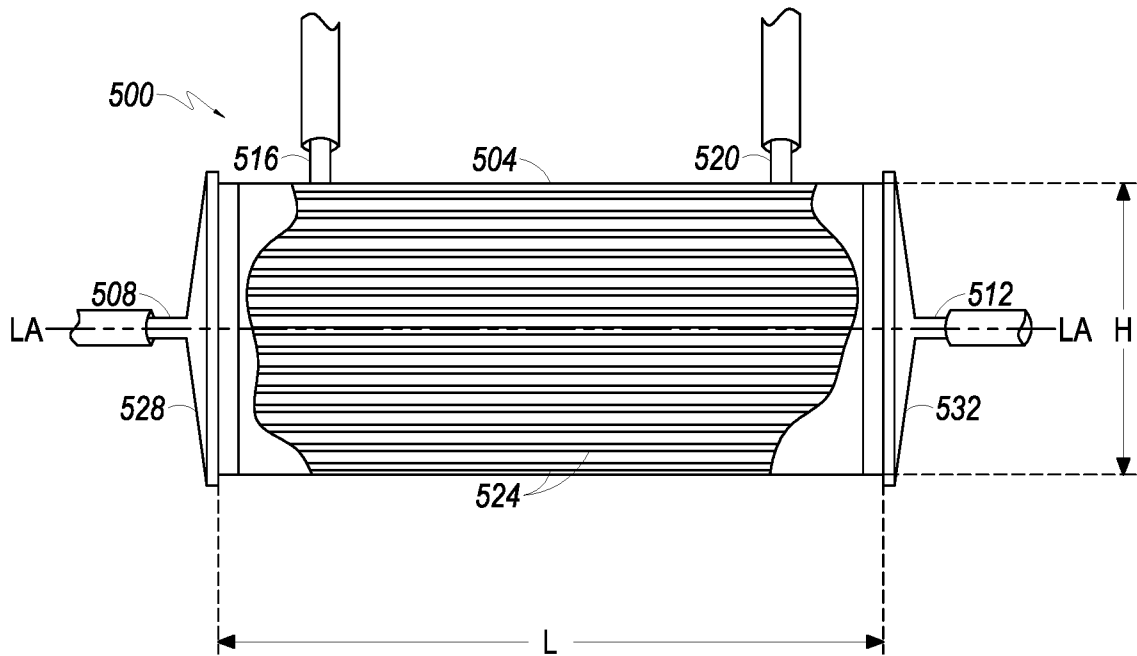

FIG. 3B

6/19

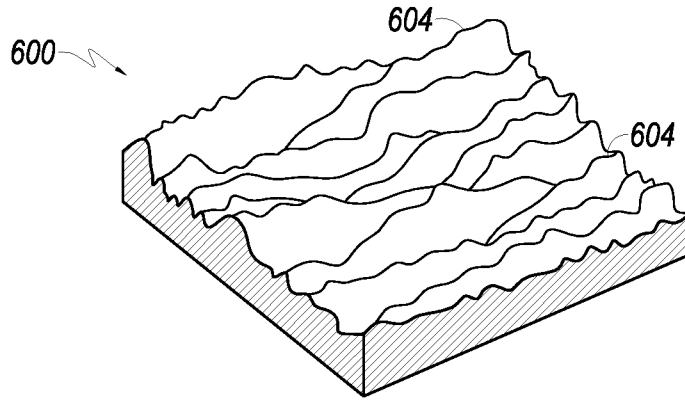

FIG. 4

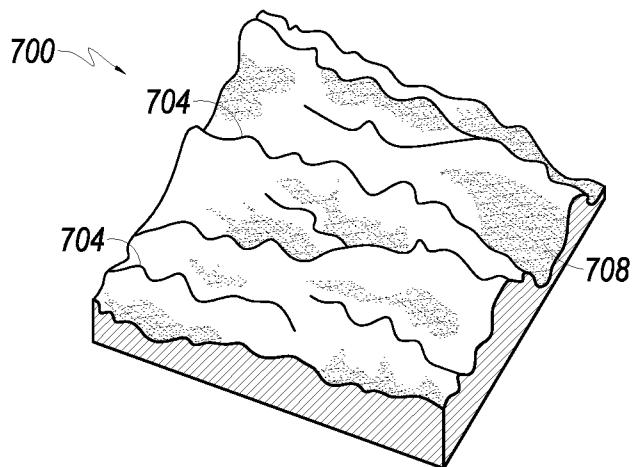

FIG. 5

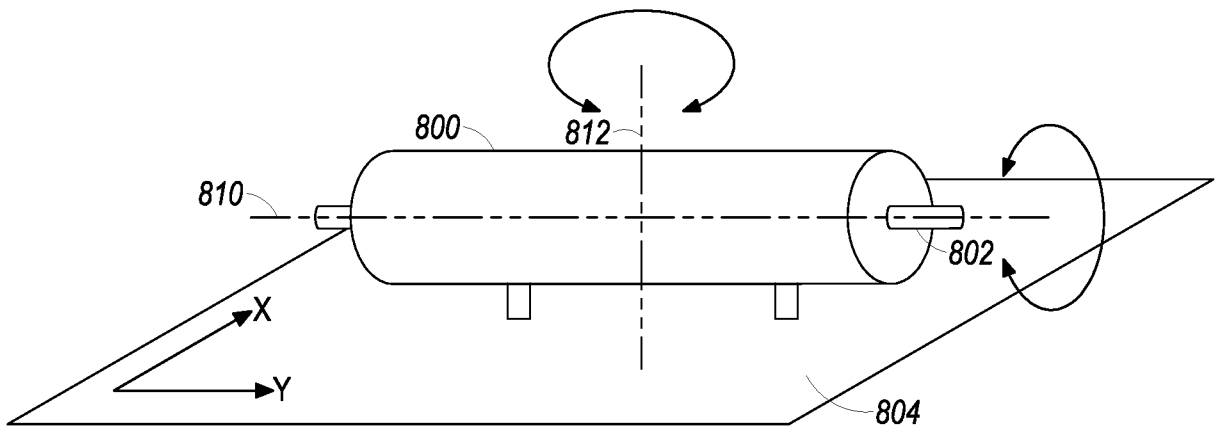

FIG. 6

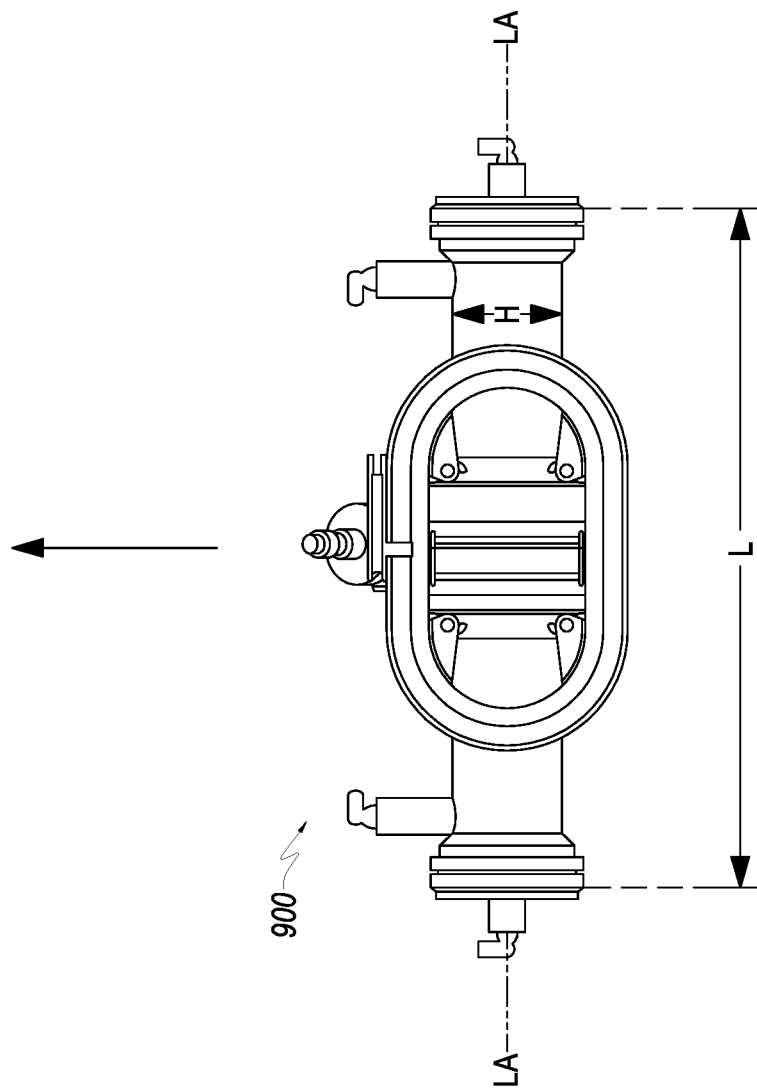

FIG. 7

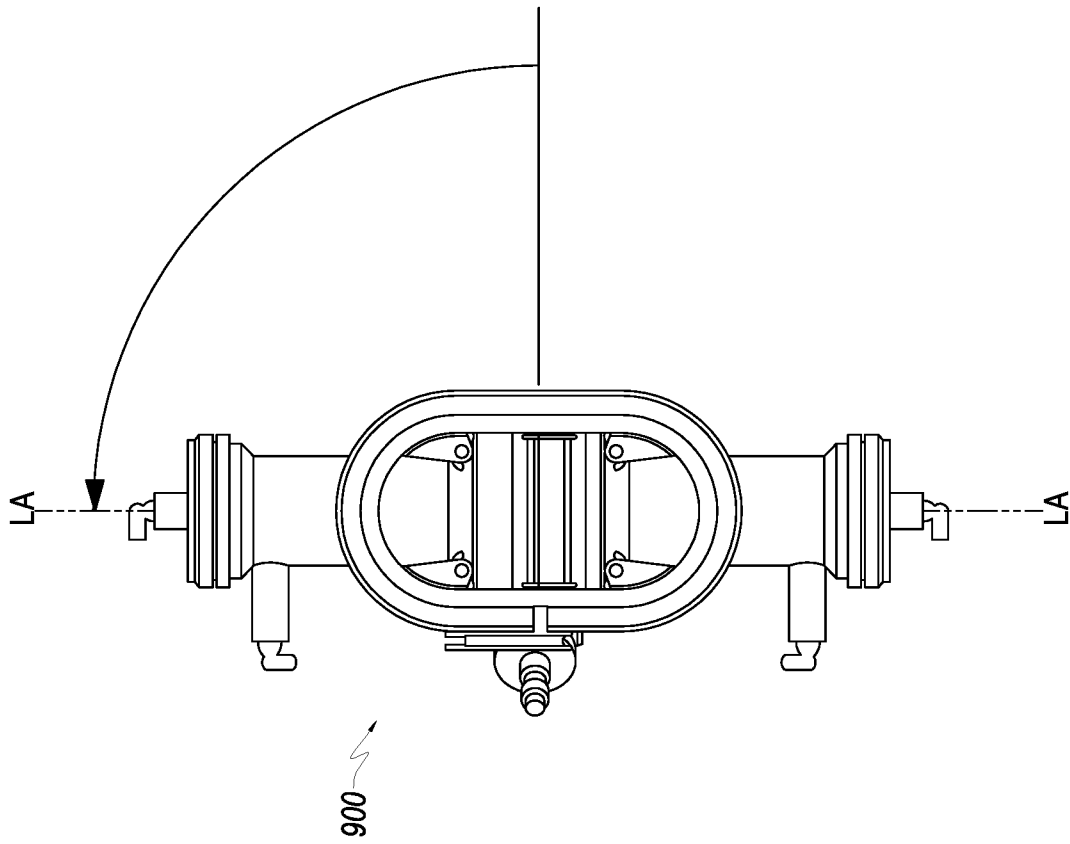

FIG. 8

10/19

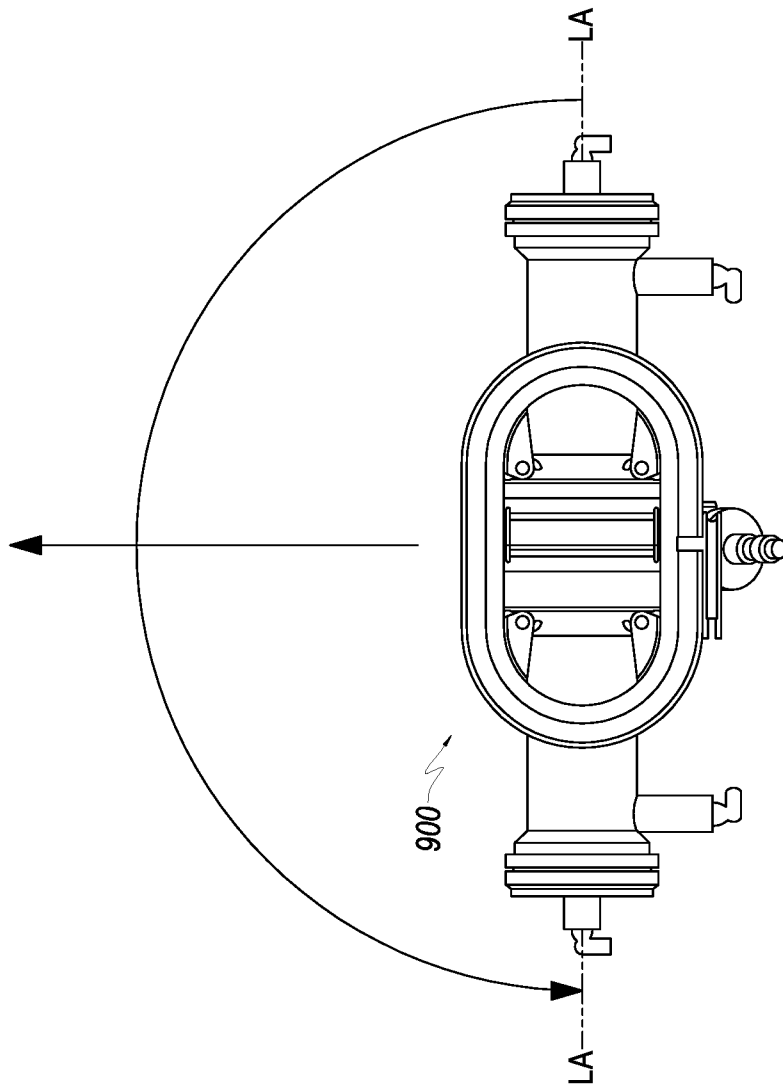

FIG. 9

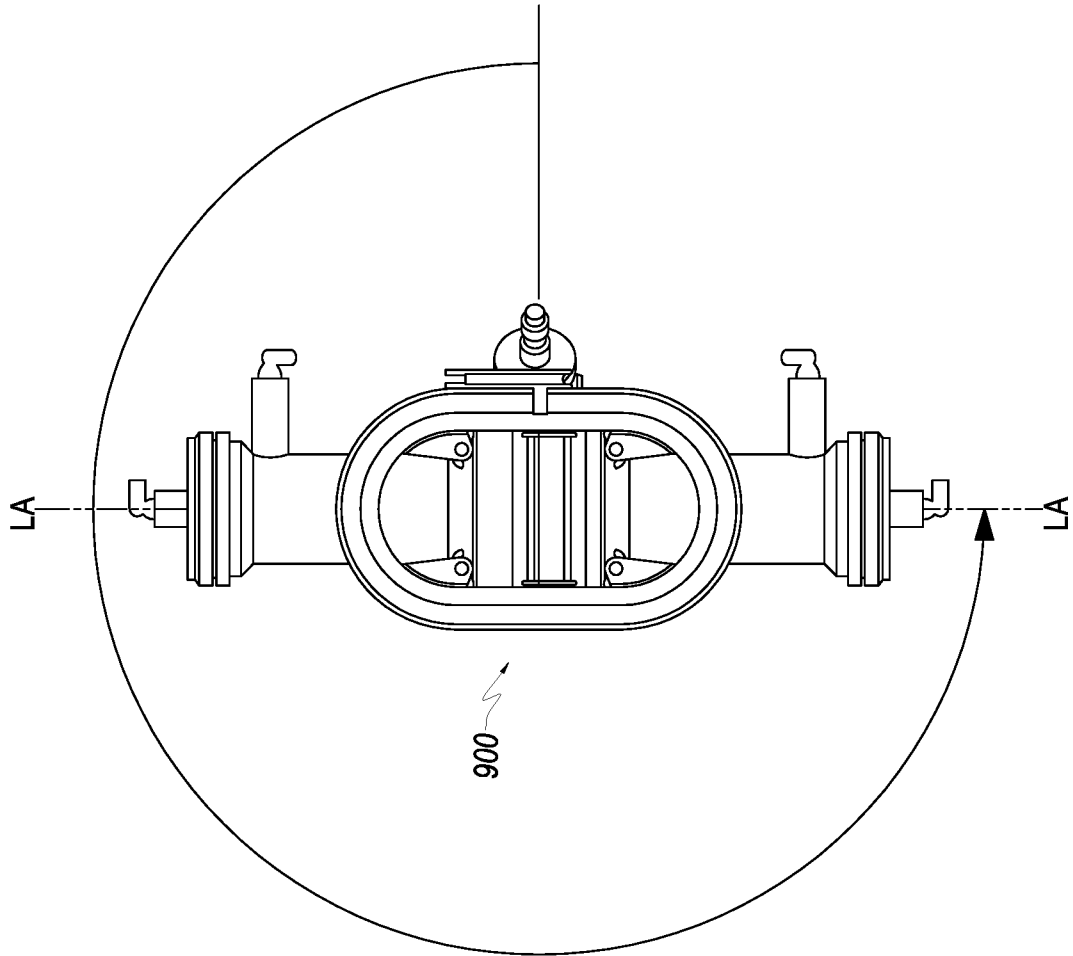

FIG. 10

12/19

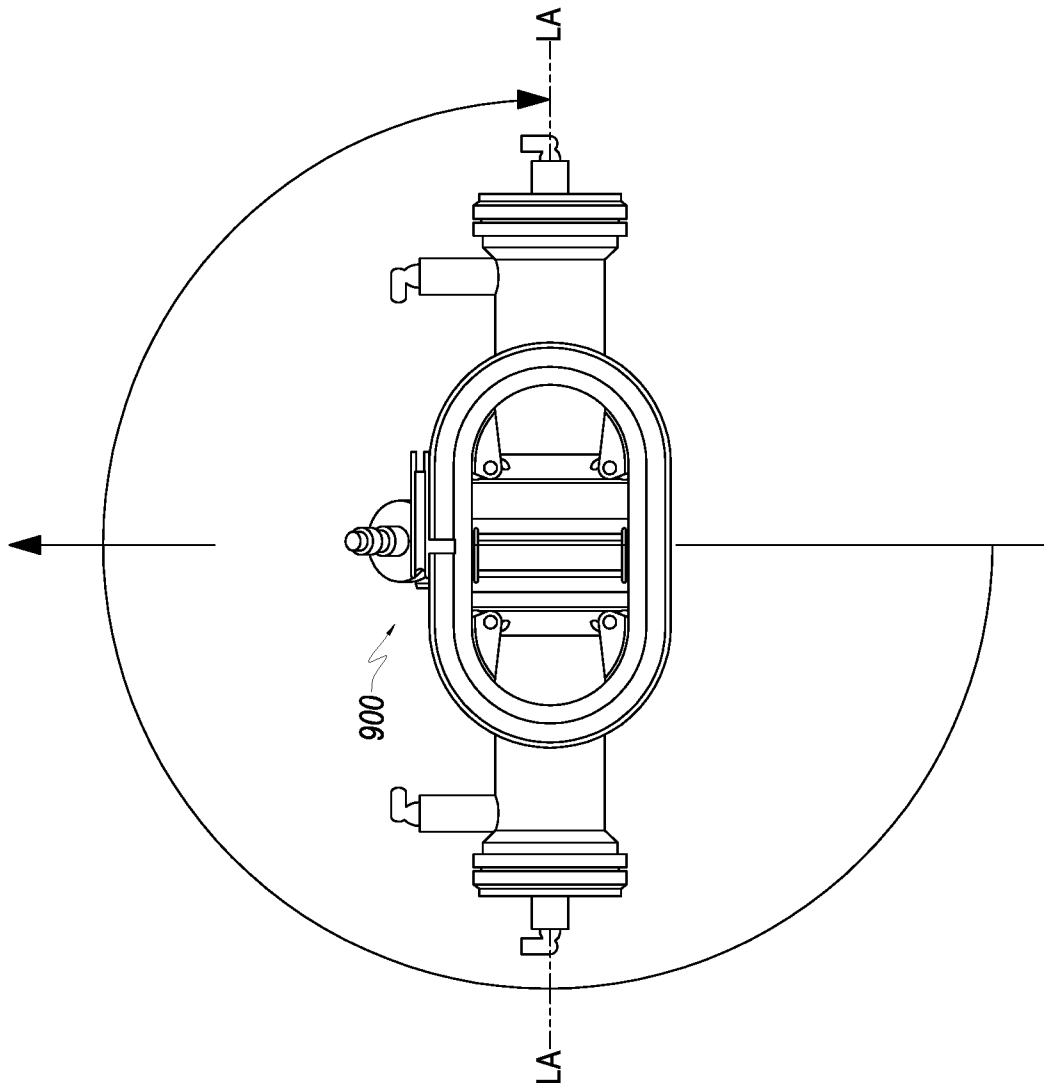

FIG. 11

13/19

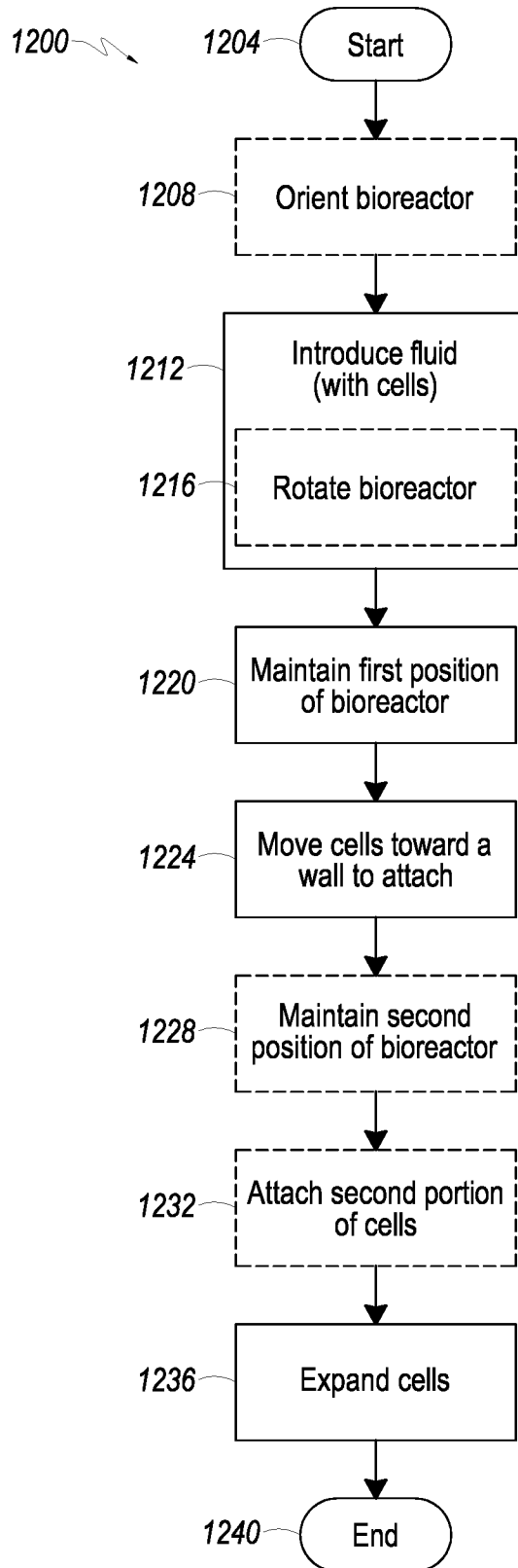

FIG. 12

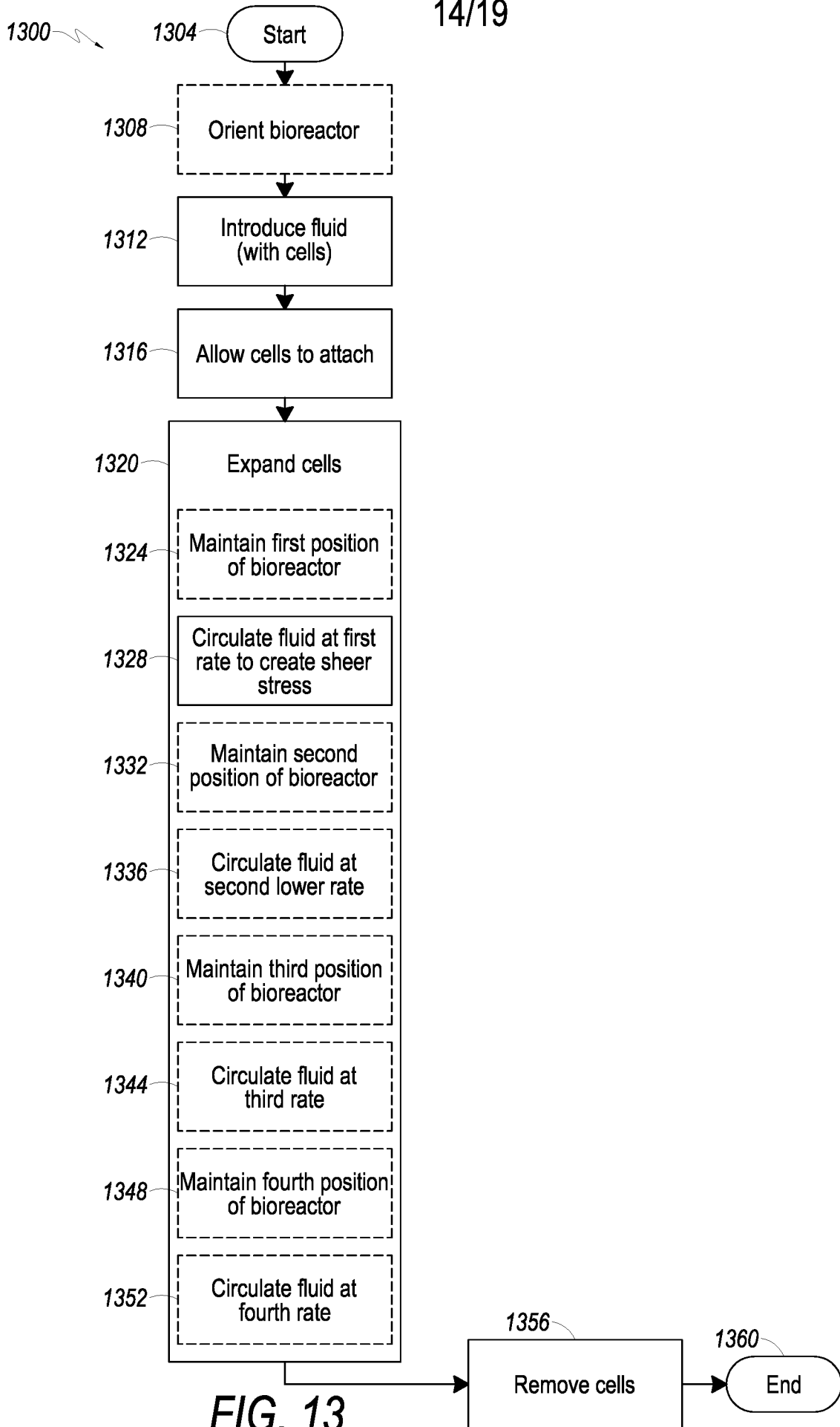
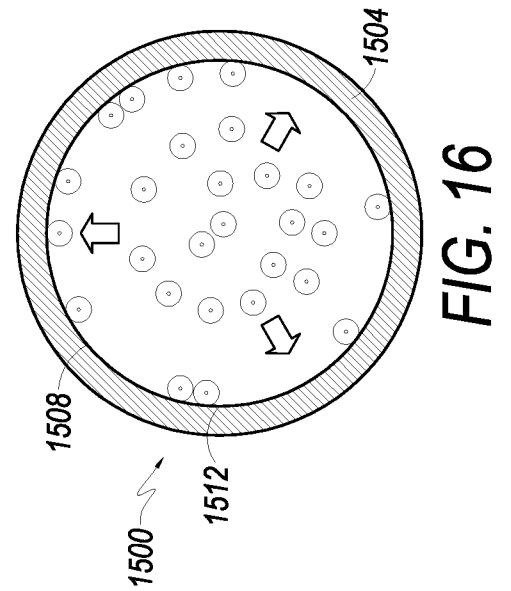
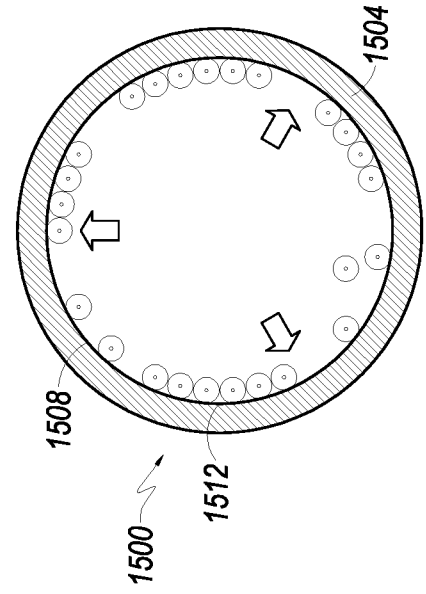
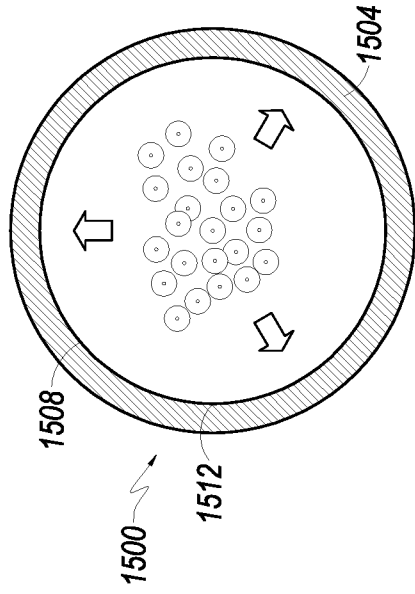
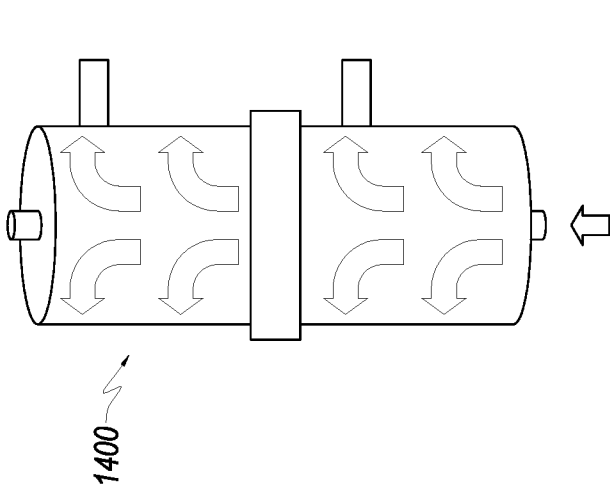

FIG. 13



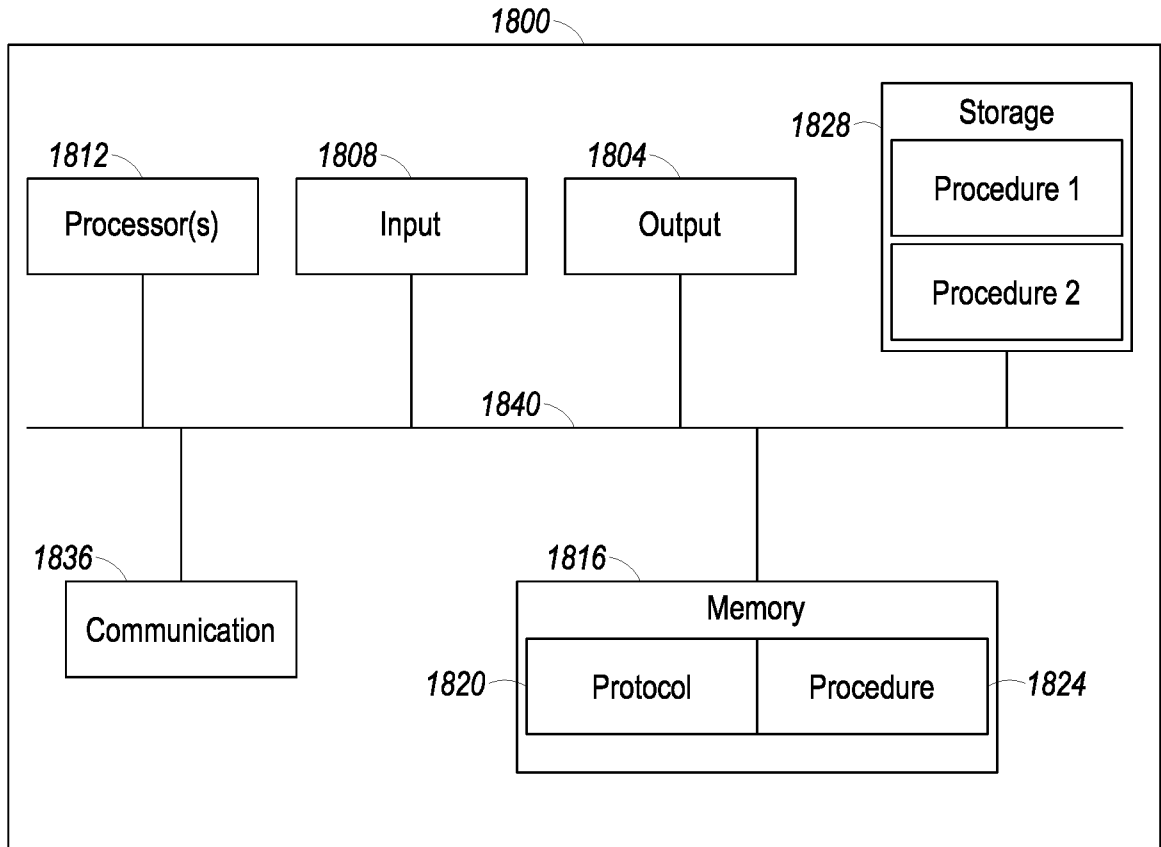

FIG. 18

17/19

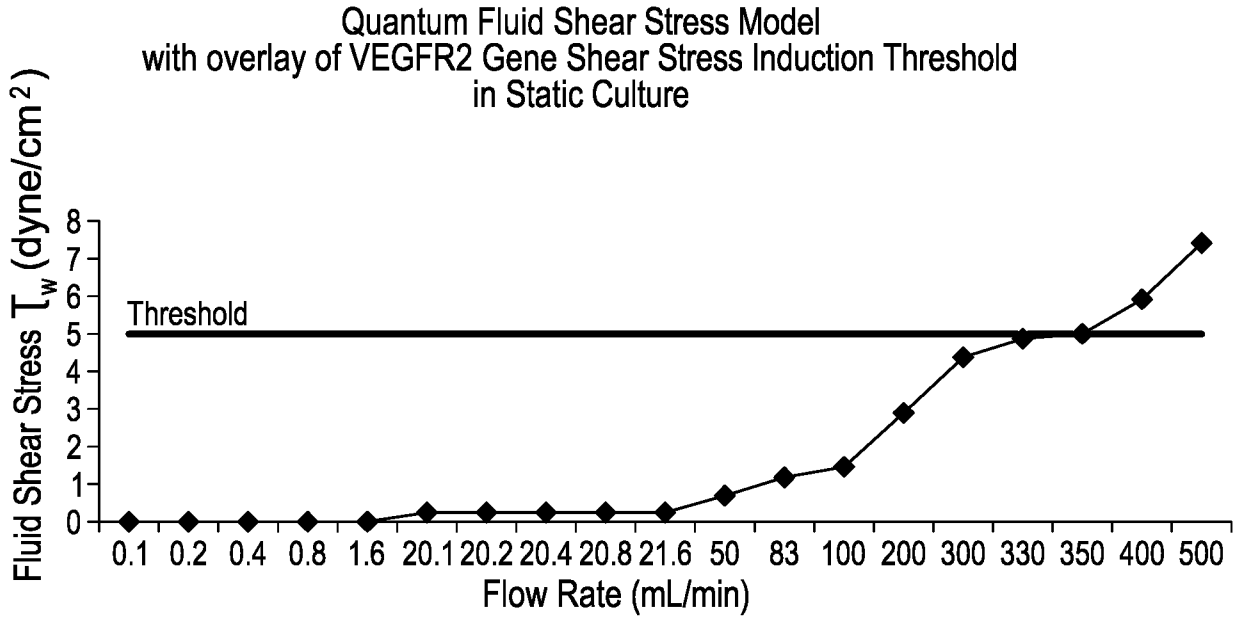

FIG. 19

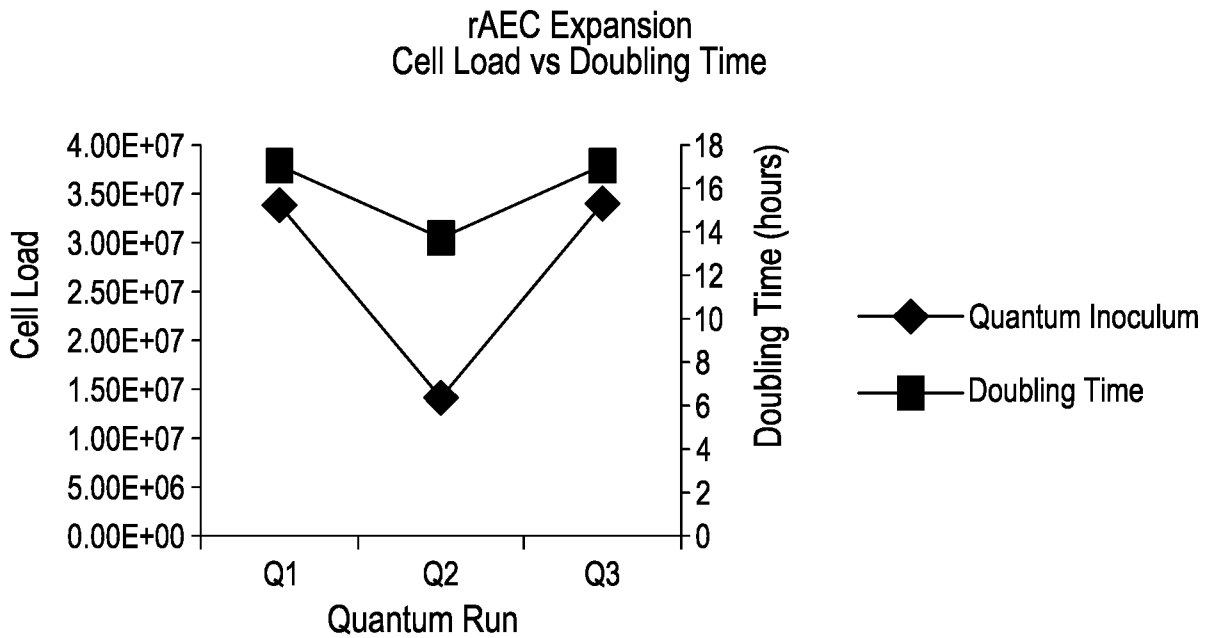

FIG. 20

18/19

rAEC-P4T1 Metabolic Profile
Q1 seeded with 3.36×10^7 cells

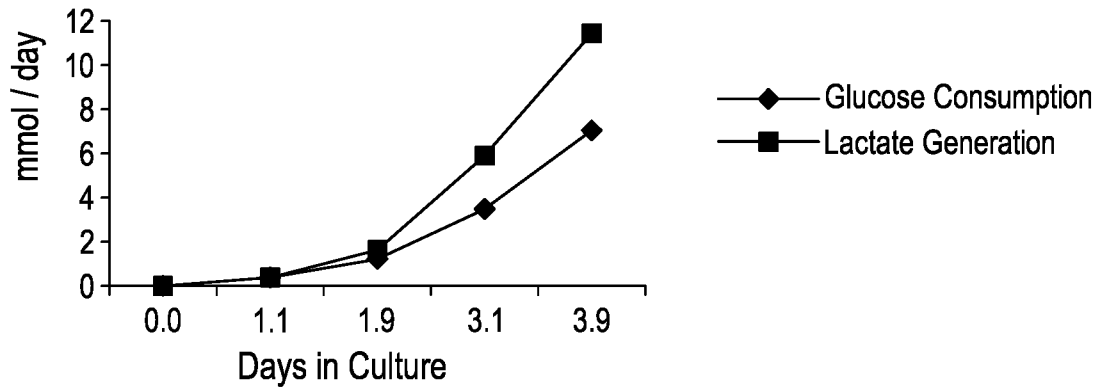

FIG. 21

rAEC-P3T1 Metabolic Profile
Q2 seeded with 1.40×10^7 cells

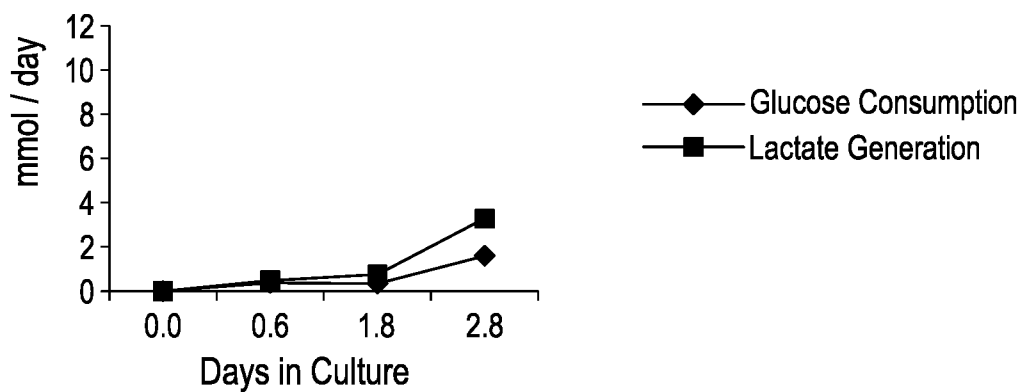

FIG. 22

19/19

rAEC-P3T1 Metabolic Profile
Q3 seeded with 3.36×10^7 cells

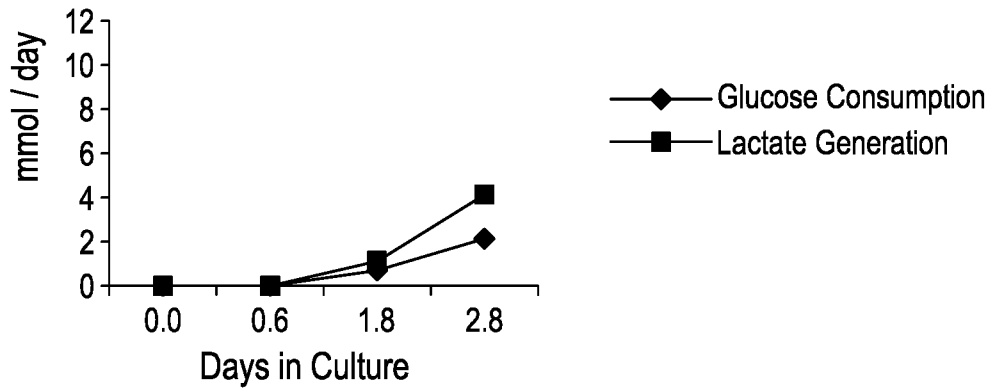

FIG. 23

Relative Quantification of VEGFR2 mRNA Expression
Quantum System vs Flask Culture of RAECs (Q3)

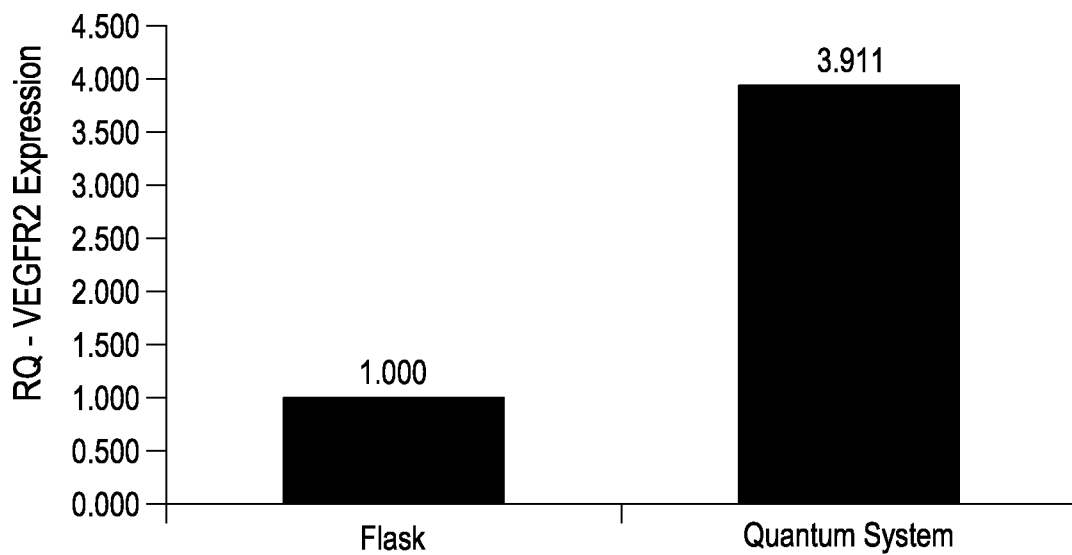

FIG. 24

INTERNATIONAL SEARCH REPORT

International application No
PCT/US2016/040855

A. CLASSIFICATION OF SUBJECT MATTER
 INV. C12M3/00
 ADD.
 According to International Patent Classification (IPC) or to both national classification and IPC

B. FIELDS SEARCHED
 Minimum documentation searched (classification system followed by classification symbols)
 C12M

Documentation searched other than minimum documentation to the extent that such documents are included in the fields searched

Electronic data base consulted during the international search (name of data base and, where practicable, search terms used)
 EPO-Internal, BIOSIS, WPI Data

C. DOCUMENTS CONSIDERED TO BE RELEVANT

Category*	Citation of document, with indication, where appropriate, of the relevant passages	Relevant to claim No.
X	PATRICK J. HANLEY ET AL: "Efficient manufacturing of therapeutic mesenchymal stromal cells with the use of the Quantum Cell Expansion System", CYTOTHERAPY, vol. 16, no. 8, 1 August 2014 (2014-08-01), pages 1048-1058, XP055172853, ISSN: 1465-3249, DOI: 10.1016/j.jcyt.2014.01.417	1-16
Y	figure 1 page 1051, left-hand column, last paragraph - right-hand column, paragraph 1 ----- -/--	17-20

Further documents are listed in the continuation of Box C.

See patent family annex.

* Special categories of cited documents :

- "A" document defining the general state of the art which is not considered to be of particular relevance
- "E" earlier application or patent but published on or after the international filing date
- "L" document which may throw doubts on priority claim(s) or which is cited to establish the publication date of another citation or other special reason (as specified)
- "O" document referring to an oral disclosure, use, exhibition or other means
- "P" document published prior to the international filing date but later than the priority date claimed

- "T" later document published after the international filing date or priority date and not in conflict with the application but cited to understand the principle or theory underlying the invention
- "X" document of particular relevance; the claimed invention cannot be considered novel or cannot be considered to involve an inventive step when the document is taken alone
- "Y" document of particular relevance; the claimed invention cannot be considered to involve an inventive step when the document is combined with one or more other such documents, such combination being obvious to a person skilled in the art
- "&" document member of the same patent family

Date of the actual completion of the international search 1 December 2016	Date of mailing of the international search report 21/12/2016
--	--

Name and mailing address of the ISA/ European Patent Office, P.B. 5818 Patentlaan 2 NL - 2280 HV Rijswijk Tel. (+31-70) 340-2040, Fax: (+31-70) 340-3016	Authorized officer Herrmann, Klaus
--	---

INTERNATIONAL SEARCH REPORT

International application No
PCT/US2016/040855

C(Continuation). DOCUMENTS CONSIDERED TO BE RELEVANT		
Category*	Citation of document, with indication, where appropriate, of the relevant passages	Relevant to claim No.
X	MARK JONES ET AL: "Genetic stability of bone marrow-derived human mesenchymal stromal cells in the Quantum System", CYTOTHERAPY, vol. 15, no. 11, 1 November 2013 (2013-11-01), pages 1323-1339, XP055160794, ISSN: 1465-3249, DOI: 10.1016/j.jcyt.2013.05.024	1-16
Y	figure 1	17-20

X	GLOECKNER H ET AL: "NEW MINIATURIZED HOLLOW-FIBER BIOREACTOR FOR IN VIVO LIKE CELL CULTURE, CELL EXPANSION, AND PRODUCTION OF CELL-DERIVED PRODUCTS", BIOTECHNOLOGY PROGRESS, AMERICAN INSTITUTE OF CHEMICAL ENGINEERS, US, vol. 17, 1 January 2001 (2001-01-01), pages 828-831, XP008072348, ISSN: 8756-7938, DOI: 10.1021/BP010069Q the whole document	1-16

X	DEKKER ROB J ET AL: "Prolonged fluid shear stress induces a distinct set of endothelial cell genes, most specifically lung Kruppel-like factor (KLF2)", BLOOD, AMERICAN SOCIETY OF HEMATOLOGY, US, vol. 100, no. 5, 1 September 2002 (2002-09-01), pages 1689-1698, XP002425163, ISSN: 0006-4971, DOI: 10.1182/BLOOD-2002-01-0046 abstract page 1691, left-hand column, last paragraph tables 1, line 2	7-16

Y	Z.-G. JIN ET AL: "Ligand-Independent Activation of Vascular Endothelial Growth Factor Receptor 2 by Fluid Shear Stress Regulates Activation of Endothelial Nitric Oxide Synthase", CIRCULATION RESEARCH., vol. 93, no. 4, 22 August 2003 (2003-08-22), pages 354-363, XP055320114, US ISSN: 0009-7330, DOI: 10.1161/01.RES.0000089257.94002.96 abstract	17-20

	-/--	

INTERNATIONAL SEARCH REPORT

International application No

PCT/US2016/040855

C(Continuation). DOCUMENTS CONSIDERED TO BE RELEVANT		
Category*	Citation of document, with indication, where appropriate, of the relevant passages	Relevant to claim No.
A	<p>BARBARA J. BALLERMANN ET AL: "Adhesion and Differentiation of Endothelial Cells by Exposure to Chronic Shear Stress: A Vascular Graft Model", BLOOD PURIFICATION., vol. 13, no. 3-4, 1 January 1995 (1995-01-01), pages 125-134, XP055319487, CH ISSN: 0253-5068, DOI: 10.1159/000170195 abstract page 127, right-hand column, last paragraph page 132, left-hand column, last paragraph - page 133, left-hand column -----</p>	1-20
A	<p>MARTIN I ET AL: "The role of bioreactors in tissue engineering", TRENDS IN BIOTECHNOLOGY, ELSEVIER PUBLICATIONS, CAMBRIDGE, GB, vol. 22, no. 2, 1 February 2004 (2004-02-01), pages 80-86, XP004486416, ISSN: 0167-7799, DOI: 10.1016/J.TIBTECH.2003.12.001 figure 1(c) page 82, left-hand column, last paragraph -----</p>	1-20

INTERNATIONAL SEARCH REPORT

International application No.
PCT/US2016/040855

Box No. II Observations where certain claims were found unsearchable (Continuation of item 2 of first sheet)

This international search report has not been established in respect of certain claims under Article 17(2)(a) for the following reasons:

1. Claims Nos.:
because they relate to subject matter not required to be searched by this Authority, namely:

2. Claims Nos.:
because they relate to parts of the international application that do not comply with the prescribed requirements to such an extent that no meaningful international search can be carried out, specifically:

3. Claims Nos.:
because they are dependent claims and are not drafted in accordance with the second and third sentences of Rule 6.4(a).

Box No. III Observations where unity of invention is lacking (Continuation of item 3 of first sheet)

This International Searching Authority found multiple inventions in this international application, as follows:

see additional sheet

1. As all required additional search fees were timely paid by the applicant, this international search report covers all searchable claims.

2. As all searchable claims could be searched without effort justifying an additional fees, this Authority did not invite payment of additional fees.

3. As only some of the required additional search fees were timely paid by the applicant, this international search report covers only those claims for which fees were paid, specifically claims Nos.:

4. No required additional search fees were timely paid by the applicant. Consequently, this international search report is restricted to the invention first mentioned in the claims; it is covered by claims Nos.:

Remark on Protest

- The additional search fees were accompanied by the applicant's protest and, where applicable, the payment of a protest fee.
- The additional search fees were accompanied by the applicant's protest but the applicable protest fee was not paid within the time limit specified in the invitation.
- No protest accompanied the payment of additional search fees.

FURTHER INFORMATION CONTINUED FROM PCT/ISA/ 210

This International Searching Authority found multiple (groups of) inventions in this international application, as follows:

1. claims: 1-6

A method of loading cells in a hollow fiber bioreactor comprising a longitudinal axis, the method comprising: introducing a first fluid comprising cells into a plurality of hollow fibers in the hollow fiber bioreactor; maintaining the longitudinal axis of the hollow fiber bioreactor at an angle greater than zero degrees from a first position, wherein the longitudinal axis is substantially horizontal when in the first position; and while maintaining the longitudinal axis of the hollow fiber bioreactor at the angle, moving the cells toward an inside wall of at least one of the plurality of hollow fibers by introducing a second fluid into the bioreactor, wherein a portion of the second fluid passes through a wall of the at least one of the plurality of hollow fibers and a portion of the cells attach to a lumen wall of the at least one of the plurality of hollow fibers.

2. claims: 7-16

A method of growing cells in a hollow fiber bioreactor, the method comprising: introducing a first fluid comprising cells into a plurality of hollow fibers in the hollow fiber bioreactor, wherein the hollow fiber bioreactor comprises a longitudinal axis; allowing the cells to attach to an inside surface of at least one of the plurality of hollow fibers; expanding the cells by circulating media in the bioreactor to feed the cells, wherein during the expanding the media is circulated at a first flow rate that subjects the cells to a fluid shear stress greater than about 0.01 dynes/cm² for a first predetermined period of time; and removing the cells from the hollow fiber bioreactor.

3. claims: 17-20

A method of growing endothelial cells, the method comprising: introducing a plurality of endothelial cells into a hollow fiber bioreactor, the bioreactor comprising: a hollow fiber membrane, wherein the hollow fiber membrane comprises a plurality of hollow fibers; and wherein each of the hollow fibers comprise an inner diameter with a radius of curvature greater than a dimension of one of the plurality of endothelial cells, and wherein each of the hollow fibers has undulating features on an interior surface; expanding the plurality of endothelial cells to generate a second plurality of cells greater than the first plurality of cells, wherein the expanding comprising circulating fluid through the hollow fiber membrane, the fluid circulating at a flow rate that subjects the plurality

FURTHER INFORMATION CONTINUED FROM PCT/ISA/ 210

of endothelial cells to a fluid shear stress that induces expression of vascular endothelial growth factor receptors; and removing the second plurality of cells from the bioreactor.
