

(19) World Intellectual Property Organization
International Bureau



(43) International Publication Date
22 January 2009 (22.01.2009)

PCT

(10) International Publication Number
WO 2009/011946 A1

(51) International Patent Classification:
G03B 21/60 (2006.01)

(21) International Application Number:
PCT/US2008/060658

(22) International Filing Date: 17 April 2008 (17.04.2008)

(25) Filing Language: English

(26) Publication Language: English

(30) Priority Data:
60/912,370 17 April 2007 (17.04.2007) US

(71) Applicant (for all designated States except US): **UNIVERSITY OF SOUTHERN CALIFORNIA** [US/US]; USC Stevens, Hughes Center Suite EEB 131, 3740 McClintock Avenue, Los Angeles, CA 90089-2561 (US).

(72) Inventors; and

(75) Inventors/Applicants (for US only): **DEBEVEC, Paul, E.** [US/US]; 4105 Pacific Avenue, #3, Marina Del Rey, CA 90292 (US). **JONES, Andrew** [GB/US]; 12492 Gilmore Avenue, #3, Los Angeles, CA 90066 (US). **BOLAS, Mark** [US/US]; 2326 Jewell Place, Mountain View, CA 94043 (US). **McDOWALL, Ian** [CA/US]; 260 Lindenbrook Road, Woodside, CA 94062 (US).

(74) Agents: **BROWN, Marc, E.** et al.; McDermott Will & Emery LLP, 2049 Century Park East, Suite 3800, Los Angeles, CA 90067 (US).

(81) Designated States (unless otherwise indicated, for every kind of national protection available): AE, AG, AL, AM, AO, AT, AU, AZ, BA, BB, BG, BH, BR, BW, BY, BZ, CA, CH, CN, CO, CR, CU, CZ, DE, DK, DM, DO, DZ, EC, EE, EG, ES, FI, GB, GD, GE, GH, GM, GT, HN, HR, HU, ID, IL, IN, IS, JP, KE, KG, KM, KN, KP, KR, KZ, LA, LC, LK, LR, LS, LT, LU, LY, MA, MD, ME, MG, MK, MN, MW, MX, MY, MZ, NA, NG, NI, NO, NZ, OM, PG, PH, PL, PT, RO, RS, RU, SC, SD, SE, SG, SK, SL, SM, SV, SY, TJ, TM, TN, TR, TT, TZ, UA, UG, US, UZ, VC, VN, ZA, ZM, ZW.

(84) Designated States (unless otherwise indicated, for every kind of regional protection available): ARIPO (BW, GH, GM, KE, LS, MW, MZ, NA, SD, SL, SZ, TZ, UG, ZM, ZW), Eurasian (AM, AZ, BY, KG, KZ, MD, RU, TJ, TM), European (AT, BE, BG, CH, CY, CZ, DE, DK, EE, ES, FI, FR, GB, GR, HR, HU, IE, IS, IT, LT, LU, LV, MC, MT, NL, NO, PL, PT, RO, SE, SI, SK, TR), OAPI (BF, BJ, CF, CG, CI, CM, GA, GN, GQ, GW, ML, MR, NE, SN, TD, TG).

Published:
— with international search report
— before the expiration of the time limit for amending the claims and to be republished in the event of receipt of amendments

(54) Title: RENDERING FOR AN INTERACTIVE 360 DEGREE LIGHT FIELD DISPLAY

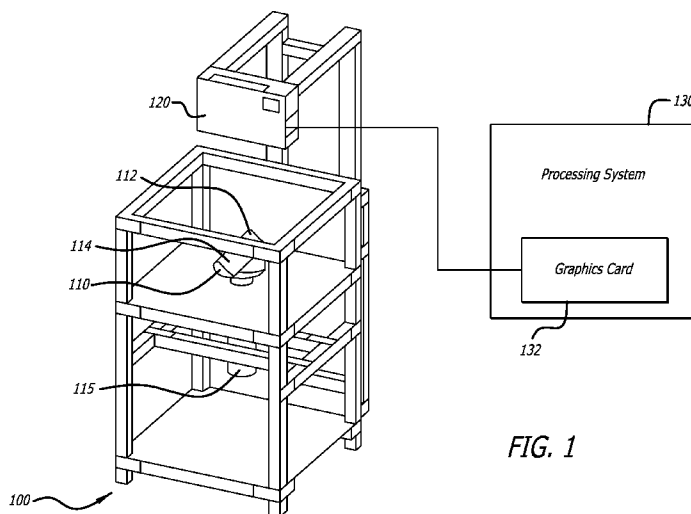

FIG. 1

(57) Abstract: An interactive, autostereoscopic system for displaying an object in 3D includes a mirror configured to spin around a vertical axis when actuated by a motor, a high speed video projector, and a processing system including a graphics card interfaced to the video projector. An anisotropic reflector is bonded onto an inclined surface of the mirror. The video projector projects video signals of the object from the projector onto the inclined surface of the mirror while the mirror is spinning, so that light rays representing the video signals are redirected toward a field of view of a 360 degree range. The processing system renders the redirected light rays so as to interactively generate a horizontal-parallax 3D display of the object. Vertical parallax can be included in the display by adjusting vertically the displayed views of the object, in response to tracking of viewer motion by a tracking system.

WO 2009/011946 A1

RENDERING FOR AN INTERACTIVE 360 DEGREE LIGHT FIELD DISPLAY**STATEMENT REGARDING FEDERALLY SPONSORED RESEARCH**

[001] This invention was made with government support under the US Army Research Office, Grant No. W911NF-04-D-0005. The government may have certain rights in the invention.

CROSS-REFERENCE TO RELATED APPLICATIONS

[002] This application claims the benefit of priority under 35 U.S.C. § 119(e) from U.S. Provisional Application Serial No. 60/912370 entitled "An Interactive 360 Degree Horizontal Parallax Light Field Display" and filed on April 17, 2007, by inventor Paul E. Debevec. The provisional application serial number 60/912370 is incorporated herein by reference in its entirety.

BACKGROUND

[003] A great deal of computer generated imagery is modeled and rendered in 3D (three dimensions). The vast majority of 3D imagery is shown on 2D displays, however. Only relatively recently have the requisite enabling technologies become available that can offer the promise of making functional and practical 3D displays possible.

[004] Many problems and challenges remain in this field. As one example, rendering 3D displays of scenes with both the correct horizontal and vertical perspectives remains a challenge. Another problem that has not yet been addressed is how to achieve 3D displays that are interactive so as to allow real time updates to the displayed images.

[005] There is a need for improved methods and systems for 3D displays that can among other things address the problems and challenges mentioned above.

SUMMARY

[006] An interactive, autostereoscopic system for displaying an object in three dimensions includes a mirror configured to spin around a vertical axis

when actuated by a motor, a high speed video projector, and a processing system including a graphics card interfaced to the video projector. An anisotropic reflector is bonded onto an inclined surface of the mirror. The video projector projects video signals of the object from the projector onto the projection surface while the mirror is spinning, so that light rays representing the video signals are redirected toward a field of view of a 360 degree range within a viewing space of one or more viewers. The processing system renders the redirected light rays so as to generate a horizontal-parallax 3D display of the object for the viewers from any of a plurality of viewing directions within the viewing space.

BRIEF DESCRIPTION OF THE DRAWINGS

[007] FIG. 1 illustrates a system for generating an autostereoscopic, multiview (horizontal-parallax-only) 3D display of an object, in one embodiment of the present disclosure.

[008] FIG. 2 illustrates the anisotropic reflectance characteristics of the mirror system illustrated in FIG. 1.

[009] FIGS. 3A, 3B, and 3C illustrate a projection process and geometry for rendering an object or scene to the system illustrated in FIG. 1, in one embodiment of the present disclosure.

[010] FIG. 4 illustrates a geometric calibration for the system illustrated in FIG. 1, in one embodiment of the present disclosure.

[011] FIG. 5 illustrates a system for dynamic rendering of a 3D display from a photographically captured 4D light field data set, in one embodiment of the present disclosure.

[012] FIGS. 6A-6B illustrate dynamic vertical rebinning to generate correct vertical parallax for a horizontal-parallax-only 3D display of a photographically captured 4D light field data set, in one embodiment of the present disclosure.

[013] FIG. 7 illustrates a two-mirror tent for displaying two-toned color imagery using orange and cyan filters below the diffusers.

DETAILED DESCRIPTION

[014] The present disclosure describes an easily reproducible, low-cost 3D display system with a form factor for displaying 3D objects in 3D. Also described are the projection mathematics and rendering methods necessary to drive the 3D display with real time raster imagery or pre-recorded light fields so that they exhibit the correct cues of both horizontal and vertical parallax. The display is autostereoscopic, requiring no special viewing glasses, and omnidirectional, allowing viewers to be situated anywhere around it. The display is also multiview, i.e. produces a correct rendition of the light field with the correct horizontal parallax and vertical perspective for any viewpoint situated at a certain distance and height around the display. If head tracking is employed to detect the height and distance of one or more of the viewers around the display, the projection equations described below allow the vertical parallax to be adjusted on the fly to allow the tracked users to properly see objects from arbitrary heights and distances, in addition to obtaining correct views from any angle around the display. The systems and methods described below use primarily commodity graphics and display components and achieve real-time rendering with non-trivial scene complexity across its entire field of view.

[015] Autostereoscopic 3D Display System

[016] FIG. 1 illustrates a system for generating an autostereoscopic 3D display of an object, in one embodiment of the present disclosure. The 3D display system 100 includes: a mirror 110 covered by an anisotropic reflector 112, a motion-control motor 115, a high-speed video projector 120, and a processing system 130 (for example a standard PC) that includes a graphics card 132 interfaced to the video projector 120 using a custom FPGA-based image decoder. The mirror 110 is configured to spin with respect to a vertical axis, when actuated by the motion-control motor 115. The spinning mirror 110 may be tilted or inclined at an angle with respect to the vertical axis, for example by about 45 degrees, to reflect rays of light from the projector 120 to all possible viewing positions around the device, allowing many viewers to view the display simultaneously.

[017] In one embodiment, illustrated in FIG. 1, the video projector 120 achieves high-speed projection by modifying an off-the-shelf projector to use a new DLP drive card with custom programmed FPGA-based circuitry. The FPGA decodes a standard DVI signal from the graphics card 132. Instead of rendering a color image, the FPGA takes each 24-bit color frame of video and displays each bit sequentially as separate frames. Thus, if the incoming digital video signal is 60Hz, the video projector 120 displays $60 \times 24 = 1,440$ frames per second. To achieve even faster rates, the video card refresh may be set to rates of about 180-240Hz. At 200Hz, the video projector 120 displays 4,800 binary frames per second. The processing system 130 (containing the graphics card 132) continuously renders new horizontal views of the subject, which in the illustrated embodiment consists of 288 images per rotation of the mirror. These views are encoded into 24-bit images and sent to the video projector 120. A complete kit consisting of the FPGA and DLP boards is now available from Polaris Road, Inc.

[018] The anisotropic reflector 112 is a holographic diffuser is bonded onto a surface of the mirror 110. In one embodiment, illustrated in FIG. 1, the anisotropic reflector 112 is a holographic diffuser. Other embodiments of the present disclosure may use different types of anisotropic reflectors, including but not limited to: a lenticular lens; and a lenslet array. The mirror surface (with the anisotropic reflector bonded thereon) provides a projection surface 114, which reflects each projector pixel to a narrow range of viewpoints. In other words, the mirror surface (onto which the anisotropic reflector bonded) provides a projection surface that reflects incident rays of light in a way that the rays are spread in a substantially vertical direction after being reflected. This configuration contrasts with previous volumetric displays, which projected images onto a spinning diffuse plane which scattered light in all directions. Such displays could not recreate view-dependent effects such as occlusion.

[019] The holographic diffuser 112 provides control over the width and height of this region. In the illustrated embodiment, the characteristics of the holographic diffuser 112 are such that the relative diffusion between x and y is approximately 1:200. Horizontally, the surface 114 is sharply specular to

maintain a 1.25 degree separation between views. Vertically, the mirror 110 scatters widely so the projected image can be viewed from essentially any height.

[020] FIG. 2 shows the anisotropic reflectance characteristics of the mirror system (i.e. the mirror 110 coupled to the motor 115 and having the holographic diffuser 112 bonded to a surface of the mirror 110). The horizontal profile of the specular lobe approximates a bilinear interpolation between adjacent viewpoints. The motion of the mirror may add some additional blur which improves reproduction of halftoned imagery at the expense of angular resolution. The holographic diffuser may be diffuse in the vertical dimension and sharply specular in the horizontal dimension. In the graph shown in FIG. 2, the dotted line plots the intensity of a laser beam as reflected by the holographic diffuser 112 and mirror 110 toward the viewers. The solid line illustrates the intensity of a thin vertical line of light from the video projector as reflected by the holographic diffuser 112 and mirror 110 toward the viewers. Finally, the dashed line illustrates the intensity of an ideal bilinear interpolation spread of a hat function whose radius matches the 1.25 degree angular separation of the successive views of the display system 100.

[021] The anisotropic holographic diffuser 112 and mirror 110 may be mounted on a carbon fiber panel and attached to an aluminum fly-wheel at 45°, in the illustrated embodiment. The flywheel spins synchronously relative to the images displayed by the video projector 120.

[022] In one embodiment, the system 100 may be synchronized as follows. Since the output frame rate of the PC graphics card is relatively constant and cannot be fine-tuned on the fly, we use the PC video output rate as the master signal for system synchronization. The projector's FPGA also creates signals encoding the current frame rate. These control signals interface directly to an Animatics SM3420D "Smart Motor" which contains firmware and motion control parameters resulting in a stable, velocity-based control loop that ensures the motor velocity stays in sync with the signals from the

projector. As the mirror rotates up to 20 times per second, persistence of vision creates the illusion of a floating object around the center of the mirror.

[023] The projector and spinning mirror yield a horizontal-parallax-only display; the image perspective does not change correctly as the viewpoint moves up and down, or forward and backward. However, the projection algorithms described further below can take into account the height and distance of the viewer to render the scene with correct perspective.

[024] If just horizontal parallax is required, a sensible course of action is to initialize this height and distance to the expected typical viewing height and distance. Since the display system described above can be implemented interactively, using the graphics card we can achieve both horizontal and vertical parallax display by using a tracking system to measure the user's height and distance.

[025] The 3D, horizontal-parallax-only display may be augmented to include correct vertical parallax in the display. In overview, correct vertical parallax may be included by tracking the motion of one or more viewers, then interactively updating the displayed images of the object in response to the tracked motion of the one or more viewers. In an embodiment in which the motion of one viewer is tracked, the displayed images of the object may be interactively updated in such a way that when the viewer is moving upward from below, the displayed image of the object appears to the viewer as if seen from above, and when the viewer is moving downward from above the displayed image of the object appears to the viewer as if seen from below. In an embodiment in which the motions of a plurality of viewers are tracked, the displayed images of the object may be interactively updated in such a way that the images of the object as displayed to each viewer is shown from a viewpoint consistent with the height of each viewer relative to the display.

[026] To include correct vertical parallax, a tracking system is thus used, for example where the viewer holds the tracking device (a sensor) to their temple, or to a video camera filming the display. Any motion tracking system known in the art may be used. In one embodiment, the tracking system may be an electromagnetic motion tracking device, such as a Polhemus Patriot

electromagnetic tracking device that can track the motion of a viewer when held by or attached to the viewer. In another embodiment, the tracking system may include one or more video cameras. In this embodiment, a plurality of video cameras may be used to observe a plurality of viewers, so that the position of each of the viewers can be determined. In yet another embodiment, the tracking system may include a plurality of depth cameras used to track the position of a plurality of viewers.

[027] The tracking data may be used by the projection algorithm (further described below) to display the scene from the correct perspective for the viewer's height and distance. In this way, the display's horizontal parallax provides binocular stereo and yields zero lag as the viewer moves his/her head horizontally, which may be one of the most common significant head motions. The effects of vertical motion and distance change are computed based on the tracked position. The display only needs to adjust the rendered views in the vicinity of each tracked user, leaving the rest of the displayed circumference optimized to the average expected viewer position.

[028] FIGS. 3A, 3B, and 3C illustrate projection process and geometry for rendering an object and/or a scene to the system illustrated in FIG. 1, in one embodiment of the present disclosure.

[029] In these figures, it is assumed that the spinning mirror (labeled as 110 in FIG. 1, re-labeled as 310 in FIG. 3A) is centered at the origin and that its axis of rotation is the vertical y -axis, with the video projector at the nodal point P above the mirror, as shown in FIG. 3A. It is further assumed that the viewpoint for which the correct perspective should be obtained is at a height h (relative to the center of the projection surface 114) and a distance d from the y - or vertical axis about which the mirror 310 rotates when actuated by the motion-control motor.

[030] By the rotational symmetry of the 3D system described above, perspective-correct imagery can be produced for any viewing position on a viewing space or viewing circle \mathbf{V} defined by h and d . This yields binocular images for a viewer facing the display since h and d will be similar for both eyes. A particular viewpoint on the circle \mathbf{V} is denoted in the present

disclosure as V' . In practice, the set of perspective-correct viewpoints \mathbf{V} need not be a continuous planar circle and can pass through a variety of tracked viewer positions at different distances and heights.

[031] At any given instant, with the spinning anisotropic mirror 310 frozen at a particular position, the 2D image projected onto the mirror is reflected out into space, covering parts of the field of view of many viewpoints on the viewing space \mathbf{V} , as shown in FIG. 3B. Since the mirror 310 provides little horizontal diffusion, each projector pixel (u, v) sends light toward one specific viewpoint V' on \mathbf{V} . The display system must ensure that each projected pixel displays the appropriate part of the scene as it should be seen from viewpoint V' . Thus, there are two questions that must be answered: First, for a 3D point Q in a scene, what is the corresponding projector pixel (u, v) that reflects to the correct viewpoint V' along the ray $\overrightarrow{QV'}$? Second, for a given projector pixel (u, v) , which ray should be traced into the scene so that the display projects the correct ray intensity? The first answer tells us how to render 3D geometric models to the display and the second answer tells us how to render ray-traceable scenes such as light fields.

[032] **Projecting from the Scene into the Projector**

[033] If the scene being rendered is a polygonal 3D model, it must be determined, for any world-space vertex Q , where it should be rendered on the projector's image for any given mirror position. To visualize this process, the 3D display system is considered as it would be viewed from above. It is noted that in the horizontal plane, the anisotropic mirror behaves in essence like a regular mirror. The optical path can thus be unfolded by reflecting the projector position P to P' across the plane of the mirror 310, as seen in FIG. 3B. A ray originating at P' passing through Q will continue out into space toward the viewers. This ray $\overrightarrow{P'Q}$ will not, in general, intersect the view circle \mathbf{V} . By assuming that the mirror diffuses rays into a vertical plane, the vertical plane containing $\overrightarrow{P'Q}$ is intersected with the viewing circle \mathbf{V} , to determine the viewpoint V' from which Q will be seen with the mirror at its given position. As explained in Appendix A to this disclosure, this diffusion plane is an

approximation to a cone-shaped reflection from the mirror, but the projection error is small for the setup described above, and may be neglected in practice.

[034] A ray is then traced from the viewpoint V' toward Q , until it intersects the surface of the mirror at M . The symbol M represents the one point on the mirror that reflects light to the viewer coming from the direction of Q . To draw onto this point from the projector, M simply needs to be projected up toward the projector's nodal point P to find the corresponding projector pixel (u, v) . Thus, illuminating a pixel at (u, v) will make it appear from viewpoint V' that 3D point Q has been illuminated. Q will eventually be rendered as it should be seen from all other viewpoints on V as the mirror rotates.

[035] With these few geometric intersections, it can be determined for any 3D point Q where it should be drawn on the projector for each position of the mirror. Seen on the display by a viewer, the observed images exhibit correct perspective projection. The above-described technique actually renders multiple-center-of-projection (MCOP) images to the projector which can not be generated using a traditional projection matrix. Specifically, the projection technique implemented by the processing system 130 (shown in FIG. 1) uses a combination of two different viewpoints P (for horizontal coordinates) and V' (for vertical coordinates). Nonetheless, the technique may easily be implemented as the vertex shader provided in Appendix B of the present disclosure, allowing an entire mesh to be rendered in a single pass. For z-buffering, vertex depth may be based on the distance from V' to Q .

[036] In the above-described MCOP projection, long straight lines should naturally appear curved in the projection. Thus, models with large polygons should be tessellated; alternatively, a fragment shader could discard incorrect pixels that lie outside the triangle.

[037] **Ray Tracing from the Projector into the Scene**

[038] If the scene to be displayed (such as a light field) is most easily ray-traced, it must be determined for each projector pixel (u, v) which ray in space - from the viewer toward the scene - corresponds to that pixel. The reflected projector position in FIG. 3B is again used, and a ray is projected

from P' through its corresponding pixel (u, v) to where it intersects the surface of the mirror at point M. Upon intersecting the diffuser, it is assumed that this ray P'M spreads into a vertical fan of light which intersects the circle of views V at V'. Seen from above, this intersection is easily calculated as a 2D line-circle intersection.

[039] It can now be seen that projector pixel (u, v) reflects from mirror point M toward viewpoint V'. Thus, the color it should display should be the result of tracing a ray from V' toward point M. If the scene being rendered is a light field, ray V'M is simply queried for the scene radiance at that point, as further described below.

[040] The fans of light from a given projector frame diverge horizontally toward multiple viewpoints. As the mirror rotates, each viewpoint around the display sees a vertical line that scans out pixels from numerous projected MCOP images to form a single perspective image. The formation of these slices may be captured using a high-speed camera. The number of slices that make up an observed image depends on the viewpoint's distance from the display. This may be tested by projecting a sequence of alternating all-black and all-white images, allowing the number of images contributing to any one viewpoint to be counted easily. Closer to the mirror, the number of images that contributes to the view increases. As the viewpoint recedes, the number of images contributing to a view decreases to a minimum of approximately ten. This number never drops to one since our video projector is not orthographic.

[041] Simpler techniques than those described above may be used to project imagery to the display, but they typically do not achieve correct perspective.

[042] **Geometric Calibration**

[043] FIG. 4 illustrates a geometric calibration process for the system illustrated in FIG. 1, in one embodiment of the present disclosure.

[044] The projection process described above (in conjunction with FIGs. 3A, 3B, and 3C) requires knowledge of the intrinsic projector parameters and its

pose relative to the spinning mirror. The world coordinates are chosen to originate at the center of the mirror, with the vertical axis (0,1,0) oriented along the mirror's axis of rotation. Calibration is relatively straightforward as only a single projector is used, and an optical path is used with a single rotating element.

[045] In the embodiment illustrated in FIG. 4, a simple and known linear calibration approach is used. This method requires at least 6 correspondences between known 3D points and their transformed 2D pixel positions. Radial lens distortion is ignored, in one embodiment, as this was measured to be insignificant. In this approach, known 3D positions are indicated by marking fixed points on the mirror surface. With the motor off, the mirror is positioned so that it faces the front of the display. A paper calibration target is attached that consists of five fiducial markers (401, 402, 403, 404, 405) on a surface 407 of a mirror 410, as seen FIG. 4. The mirror 410 spins when actuated by a motor 415, by analogy to the mirror 110 described in conjunction with FIG. 1.

[046] A centered crosshair pattern is projected from the projector so that it can be positioned directly above the center fiducial. In this embodiment, the video projector (not shown in FIG. 4; shown and labeled as 120 in FIG. 1) is mounted so that its central projected pixel projects down vertically. A mouse may be used to move the crosshair to each of the other fiducial markers, clicking the mouse to obtain the position of the corresponding projector pixel. The mirror 410 is then rotated 180°, and then the four fiducials are clicked again, obtaining a total of eight 2D points. The eight fiducial positions form a unit cube in space.

[047] **Dynamic Rendering of 3D Display From 4D Light Field Data Set**

[048] Using the ray tracing projection described above in conjunction with FIGs. 3A, 3B, and 3C, 4D (four dimensional) light fields may be captured, preprocessed, and dynamically rendered to the display system described above, with correct horizontal and vertical parallax.

[049] FIG. 5 is a schematic block diagram of a system 500 for dynamic

rendering of a 3D display from a photographically captured 4D light field data set, in one embodiment of the present disclosure. In overview, the system 500 includes a video camera 510, a motorized turntable 520 that rotates around an axis of rotation 522 when actuated, a high speed video projector 530, a mirror 540 configured to spin when actuated by a motion-control motor 550, and a processing system 560 that contains a graphics card 562 interfaced to the video projector 530.

[050] As a first step, the system 500 captures a 4D light field of a real object 580 (that is to be rendered). In the illustrated embodiment, the object 580 is placed on the motorized turntable 520. The video camera 510 is placed at a distance D in front of the object. In the illustrated embodiment, D may be about 1.0 m, although D may of course be varied in different embodiments of the present disclosure. The object 580 is lit, for example with ambient light and/or lights attached to the turntable 520 or elsewhere, so that in one embodiment, the object 580 and its illumination remain substantially in the same relationship to each other during the rotation of the turntable 520 and the object 580.

[051] In the illustrated embodiment, the video camera 510 captures a movie sequence of at least 288 frames of the object 580 rotating 360° on the turntable 520. This takes a few seconds. In one embodiment, the system 500 may capture a full 4D light field by shooting (with the video camera 510) multiple rotations of the turntable 520, raising the camera's height H by about 1.25cm for each successive rotation. The intrinsic parameters for the camera may be calibrated, the and its pose may be recorded for each rotation.

[052] **Preprocessing the Light Field**

[053] As explained above, regular perspective images shown directly on the projector may not produce correct perspective to viewers around the display. Thus, the processing system 560 pre-processes the light field to produce images appropriate for projection. First, the object 580 and display coordinate systems are aligned by placing the origin at a point within the center of the object directly above the center of the turntable. The y axis is aligned to the turntable's axis of rotation 522.

[054] Then, for each slice i of the captured light field taken from height H_i , a new, rebinned, light field slice is generated as follows. The virtual viewing space or viewing circle \mathbf{V} is placed around the display at height H_i and distance D . Then, for each of the 288 mirror positions, rays are traced from the reflected projector at P' through each pixel (u, v) to the mirror at M through to the view-point V' on \mathbf{V} and then back toward M as described above in conjunction with FIGs. 3A- 3C. The light field then simply needs to be queried for its radiance along ray $\overrightarrow{V'M}$. This is a simple query since \mathbf{V} was chosen to be coincident with the height and distance of the current slice of the light field: V' thus lies on or between two of the same slice's camera locations C_i and C_{i+1} as in FIG. 3C. To obtain the final pixel value, one only needs to bilinearly interpolate between the pixels from C_i and C_{i+1} that look toward point M on the mirror.

[055] For the display, the rebinned slices are then dithered to create binary images. Sets of 24 halftoned images are packed into 24-bit color images. As there are 288 images in each rebinned slice, this yields twelve 24-bit color images per row. At 768 x 768 resolution, one slice requires just over 20MB of texture memory, allowing a light field resolution of over 768 x 768 pixels by 288 x 32 views to be stored on a modern 768MB graphics card.

[056] By construction, each one of the rebinned light field slices yields correct perspective when projected on the display and observed anywhere from the original slice's height H_i and distance D . If the viewer distance remains near distance D , one could produce accurate vertical parallax by swapping which slice is displayed according to the user's height. To render the light field accurately for any height and distance, a dynamic rebinning process is used as described below.

[057] **Dynamic Rebinning for Vertical Parallax**

[058] FIGs. 6A-6B illustrate dynamic vertical rebinning to generate correct vertical parallax for a horizontal-parallax-only 3D display of a photographically captured 4D light field data set, in one embodiment of the present disclosure.

[059] In the illustrated embodiment, a dynamic vertical rebinning is performed that samples from different preprocessed light field slices based on the viewer's height h and distance d to produce correct horizontal and vertical perspective on the light field for any viewpoint. For each mirror position, each slice i 's nodal point is considered at distance D and height H_i in front of the mirror as shown in FIG. 6A. FIG. 6A shows vertical light field rebinning that is performed by projecting the light field slice closest in angle to the viewpoints (601, 602, 603, 604, 605, 606, and 607) onto each area of the mirror 610. The midpoints between the slices are projected through the viewer position onto the mirror, and then up into the projector image. These projected midpoints form an axis of points crossing the center of the projector image. Lines from each point are extended perpendicularly to this axis, dividing the projector's image into a set of regions or areas 650, each one corresponding to the area for which light field slice i contains the rays that most closely correspond to the viewpoint's view of the scene over that area.

[060] The regions are delimited as quadrilaterals (650, 651, and 652) that extend wide enough to cover the image as seen in FIG. 6B. FIG. 6B shows that these projected regions define textured quadrilaterals (650, 651, 652) on the mirror surface. For each quadrilateral, a texture-mapped polygon is rendered that copies over the corresponding region from each light field slice. A projected image may be built up from these different slices. The areas corresponding to different original slices may be made visible by inverting every other quadrilateral of the dynamically rebinned projector frame.

[061] If the viewer is close to distance D from the display, just one or two light field slices will constitute the projected images. As the viewer moves forward or back from D , the number of slices used will increase. Since the images on the graphics card are already dithered, no blending is performed between the slices. However, the seams between the slices may not be noticeable if the light field is of sufficient vertical angular resolution.

[062] Instead of using the graphics card's memory to store multiple vertical slices of an object's light field, multiple temporal samples may be stored of a horizontal-parallax-only light field. For example, photographs from a 25-

frame animated light field may be captured and rendered using a known flowed reflectance field rendering technique. Alternatively, light fields from multi-camera systems could be used, or a high-speed single-camera system using a spinning mirror to vary the viewpoint could be used to capture such data.

[063] Displaying Color Imagery

[064] A number of methods may be used to display color imagery. A straightforward method to create a color version of the above-described 3D display may use a 3-chip DMD projector.

[065] Alternatively, a two-channel field-sequential color system may be implemented using a two-sided tent-shaped diffusing mirror 710 shown in FIG. 7. For each side of the tent, a color filter may be placed between a holographic diffusing film and a first-surface of the mirror 710. This avoids introducing specular first-surface reflections. In one exemplary embodiment, a Lee #131 cyan filter may be chosen for one side 720 of the mirror 710 and a Lee #020 orange filter (symbolically illustrated with stripes) for the other side 730, dividing the visible spectrum approximately evenly into short and long wave-lengths. The RGB (red, blue and green) colors may be converted to Orange-Cyan colors by projecting the linear RGB vector onto the plane spanned by the Orange and Cyan colors.

[066] To render in color, each plane of the tent mirror may be calibrated independently as described earlier. Then, the 3D scene may be rendered twice for each sub-frame, once for the orange side and once for the cyan side. The calibration process ensures that each side is rendered toward the appropriate set of viewpoints. The effect for the viewer is similar to the Kinemacolor 2-color cinema system, and the choice of filters allows for useful color reproduction for many scenes. Besides achieving color, the tent-mirror system doubles the number of images per second shown to the viewers, allowing a 40Hz field-sequential color frame rate which appears significantly more stable than 20Hz monochrome. Additional color channels and/or update rates may be achieved using additional mirrors in the arrangement, making the set of mirrors resemble a multi-sided pyramid.

[067] In sum, methods and systems have been described that allow an autostereoscopic light field display to present interactive 3D graphics to multiple simultaneous viewers 360 degrees around the display, including rendering techniques used to generate the imagery on the display. Using a standard programmable graphics card, over 5,000 images per second of interactive 3D graphics may be rendered, projecting 360-degree views with 1.25 degree separation up to 20 updates per second. The system's projection geometry and its calibration process have been described. A multiple-center-of-projection rendering technique has been presented for creating perspective-correct images from arbitrary viewpoints around the display.

[068] The projection techniques described in the present disclosure allow correct vertical perspective and parallax to be rendered for any height and distance when these parameters are known, and this effect may be demonstrated with interactive raster graphics using a tracking system to measure the viewer's height and distance. Finally, the projection techniques described in the present disclosure have been applied to the display of photographed light fields with accurate horizontal and vertical parallax.

[069] The previous description of the disclosed embodiments is provided to enable any person skilled in the art to make or use the present invention. Various modifications to these embodiments will be readily apparent to those skilled in the art, and the generic principles defined herein may be applied to other embodiments without departing from the spirit or scope of what is disclosed above. Thus, the apparatuses and methods described above are not intended to be limited to the embodiments shown herein, but are to be accorded the full scope consistent with the claims, wherein reference to an element in the singular is not intended to mean "one and only one" unless specifically so stated, but rather "one or more."

[070] All structural and functional equivalents to the elements of the various embodiments described throughout this disclosure that are known or later come to be known to those of ordinary skill in the art are expressly incorporated herein by reference, and are intended to be encompassed by the claims. Moreover, nothing disclosed herein is intended to be dedicated to the

public regardless of whether or not such disclosure is explicitly recited in the claims. No claim element is to be construed under the provisions of 35 U.S.C. §112, sixth paragraph, unless the element is expressly recited using the phrase "means for" or, in the case of a method claim, the element is recited using the phrase "step for."

What is claimed is:

1. A system for generating an autostereoscopic 3D display of an object, comprising:

a mirror configured to spin around a vertical axis when actuated by a motor, a surface of the mirror being inclined at an angle with respect to the vertical axis;

an anisotropic reflector bonded onto the inclined surface of the mirror so as to provide a projection surface that reflects incident rays of light in a way that the rays are spread in a substantially vertical direction after being reflected;

a high speed video projector configured to project video signals of the object onto the projection surface while the mirror is spinning and the video projector is substantially stationary, so that light rays of the video signals are redirected by the projection surface toward a field of view of a 360 degree range within a viewing space V of one or more viewers; and

a processing system interfaced to the video projector, the processing system configured to render 3D images of the object from the redirected light rays so as to generate a horizontal-parallax 3D display of the object for the viewers from any of a plurality of viewing directions within the viewing space V.

2. The system of claim 1, wherein the anisotropic reflector is a holographic diffuser.

3. The system of claim 1, wherein the anisotropic reflector is a lenticular lens.

4. The system of claim 1, wherein the anisotropic reflector is a lenslet array.

5. The system of claim 1, wherein the processing system is configured to render the 3D images of the object by tracing the light rays into

corresponding viewpoints in the viewing space V.

6. The system of claim 5, wherein each pixel in the video signals is represented by a corresponding light ray of the video signals, and wherein the processing system is configured to render the 3D images of the object by projecting each pixel in the video signals onto a corresponding viewpoint in the viewing space V, in a way that the projected pixel displays an appropriate part of the object as seen from the viewpoint so as to obtain the correct perspective for that viewpoint.

7. The system of claim 6, wherein for a viewpoint located at a height h relative to the center of the projection surface and a distance d from the vertical axis, the processing system is configured to obtain the correct perspective for that viewpoint by:

defining a position P' that represents a reflection of a position P of the video projector across the plane of the mirror, at a given position of the spinning mirror;

determining a viewpoint V' on the viewspace V from which a point Q on the object will be seen, by tracing a ray from the position P' of the reflected video projector through each point Q , for each orientation of the spinning mirror;

tracing a ray from the viewpoint V' toward Q until the ray intersects the surface of the mirror at a point M on the mirror, where M is the point on the mirror that reflects light to the viewer coming from the direction of Q ; and

projecting the point M up toward the position P to find a corresponding projector pixel coordinate (u,v) for each point Q .

8. The autostereoscopic system of claim 1, wherein the processing system is further configured to render MCOP (multiple center of projection) images of the object from the redirected light rays so as to pre-correct for distortions introduced when the light rays of video signals are reflected and redirected from the projection surface of the spinning mirror and when the light rays are traced into one or more viewing directions in the field of view.

9. The autostereoscopic system of claim 1, wherein the processing system is further configured to interactively update the displayed images of the object in real time.

10. The system of claim 9, further comprising a tracking system configured to interactively track a motion of a viewer in real time, and wherein the processing system is further configured to augment the horizontal-parallax 3D display to include vertical parallax, by adjusting vertically one or more displayed views of the object, in response to the motion of the viewer tracked by the tracking system, so that when the viewer is moving upward from below the displayed view of the object appears to the viewer as if seen from above, and when the viewer is moving downward from above the displayed view of the object appears to the viewer as if seen from below.

11. The system of claim 10, wherein the tracking system is a magnetic tracking device configured to track a motion of a viewer when held by or attached to the viewer.

12. The system of claim 10, wherein the tracking system comprises one or more video cameras configured to observe a plurality of viewers so that a position of each of the viewers can be determined.

13. The system of claim 10, wherein the tracking system comprises one or more depth cameras configured to track a position of a plurality of viewers.

14. A method of generating an interactive, autostereoscopic, 3D horizontal-parallax-only display of an object, comprising:

projecting video signals of the object from a high speed video projector onto a surface of a spinning mirror, wherein the surface has an anisotropic reflector bonded thereto so that light rays of the video signals are redirected by the surface toward a field of view of a 360 degree range within a viewing space of one or more viewers; and

interactively rendering 3D images of the object so as to generate a horizontal-parallax-only 3D display of the object for the viewers from any of a

plurality of viewing directions within the viewing space, by projecting each pixel in the video signals onto a corresponding viewpoint in the viewing space in a way that the projected pixel displays an appropriate part of the object as should be seen from the viewpoint; wherein each pixel of the video signals is represented by a corresponding light ray of the video signals.

15. A method of augmenting a 3D, autostereoscopic, horizontal parallax-only display of an object to include vertical parallax in the 3D display, comprising:

tracking a motion of a viewer; and

interactively updating the displayed images of the object in response to the tracked motion of the viewer, so that when the viewer is moving upward from below the displayed view of the object appears to the viewer as if seen from above, and when the viewer is moving downward from above the displayed view of the object appears to the viewer as if seen from below.

16. A method of augmenting a 3D, autostereoscopic, horizontal parallax-only display of an object to include vertical parallax in the 3D display, comprising:

tracking motions of a plurality of viewers; and

interactively updating the displayed images of the object in response to the tracked motions of the viewers, so that images of the object that are displayed to each of the viewers is shown from a viewpoint consistent with a height of each viewer relative to the display.

17. A system for dynamically rendering a 3D display of an object from a 4D light field data set of the object, comprising:

a mirror configured to spin around a vertical axis when actuated by a motor, a surface of the mirror being inclined at an angle with respect to the vertical axis;

a high speed video projector configured to project the 4D light field data set of the object onto the inclined surface of the mirror while the mirror is spinning, so that the 4D light field data set is redirected toward a field of view of a 360 degree range within a viewing space of one or more viewers;

and

a processing system interfaced to the video projector, the processing system configured to generate and display a horizontal-parallax 3D display of the object by pre-processing the 4D light field data set by dynamically rebinning each slice of the captured 4D light field data set, so that each of the rebinned light field slices yields a correct perspective when projected on the 3D display.

18. The system of claim 17, further comprising a video camera configured to capture the 4D light field data set of the object by recording a sequence of photographic images of the object while the object is illuminated and is rotating 360 degrees.

19. The system of claim 18, wherein the video camera is configured to record the movie sequence by filming the object while the object undergoes a plurality of rotations and while a height at which the camera is positioned is raised by a predetermined amount for each successive rotation.

20. The system of claim 17, wherein the processing system is configured to dynamically rebin each slice i of the captured 4D light field data set by:

placing a virtual viewing circle V around the 3D display at a height H_i and a distance D , where H_i represents the height of the camera for slice i , and D represents the distance from the object at which the video camera is placed;

for each mirror orientation, tracing rays from the reflected projector at a point P' through each pixel (u,v) to the mirror at M through to the viewpoint V' on V and then back toward M , querying the light field for its radiance along ray $V'M$, then interpolating between the pixels from nearest cameras C_i and C_{i+1} that look toward point M on the mirror; and

dithering the rebinned slices to create binary images of the object.

21. The system of claim 20, wherein the processing system is further configured to perform dynamic vertical rebinning to produce a correct horizontal and vertical perspective on the 4D light field for any viewpoint, by

sampling from different preprocessed light field slices based on a height h and distance d of the viewer.

22. A method of dynamically rendering a 3D display of an object from a 4D light field data set of the object, comprising:

illuminating the object and recording a movie sequence of the illuminated object while the object is rotating 360 degrees on a motorized turntable, wherein the movie sequence comprises a sequence of photographic images of the rotating object recorded by the video camera at different points in time;

projecting the recorded 4D light field data set of the object onto a surface of a mirror while the mirror is spinning, so that the 4D light field data set is redirected in substantially all viewing directions in a 360 degree range within a viewing space of one or more viewers;

pre-processing the light field data set by dynamically rebinning each slice of the captured 4D light field data set so that each of the rebinned light field slices yields a correct perspective when projected on the 3D display; and

generating an animated horizontal-parallax 3D display of the object from the rebinned light field data set.

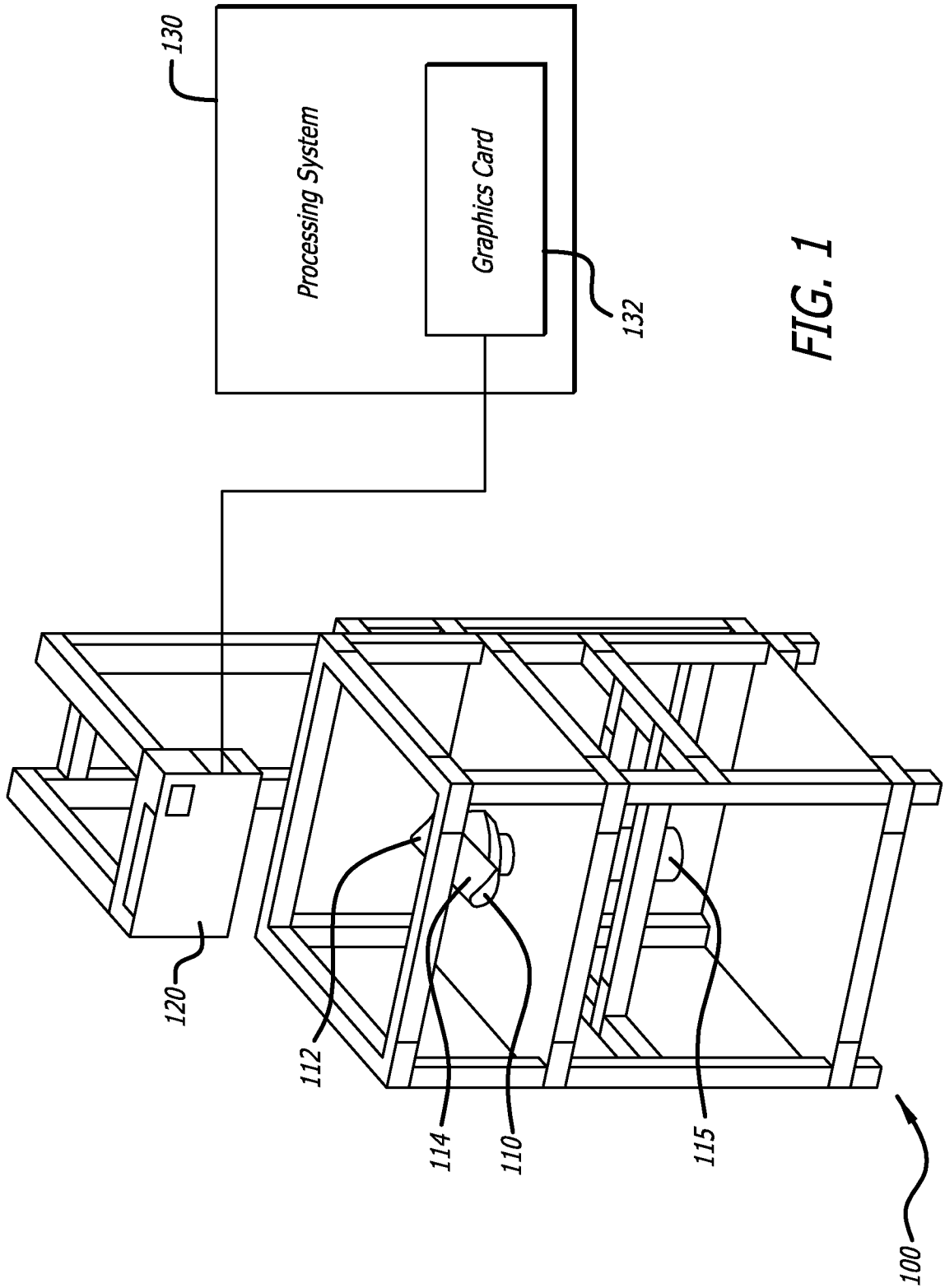

FIG. 1

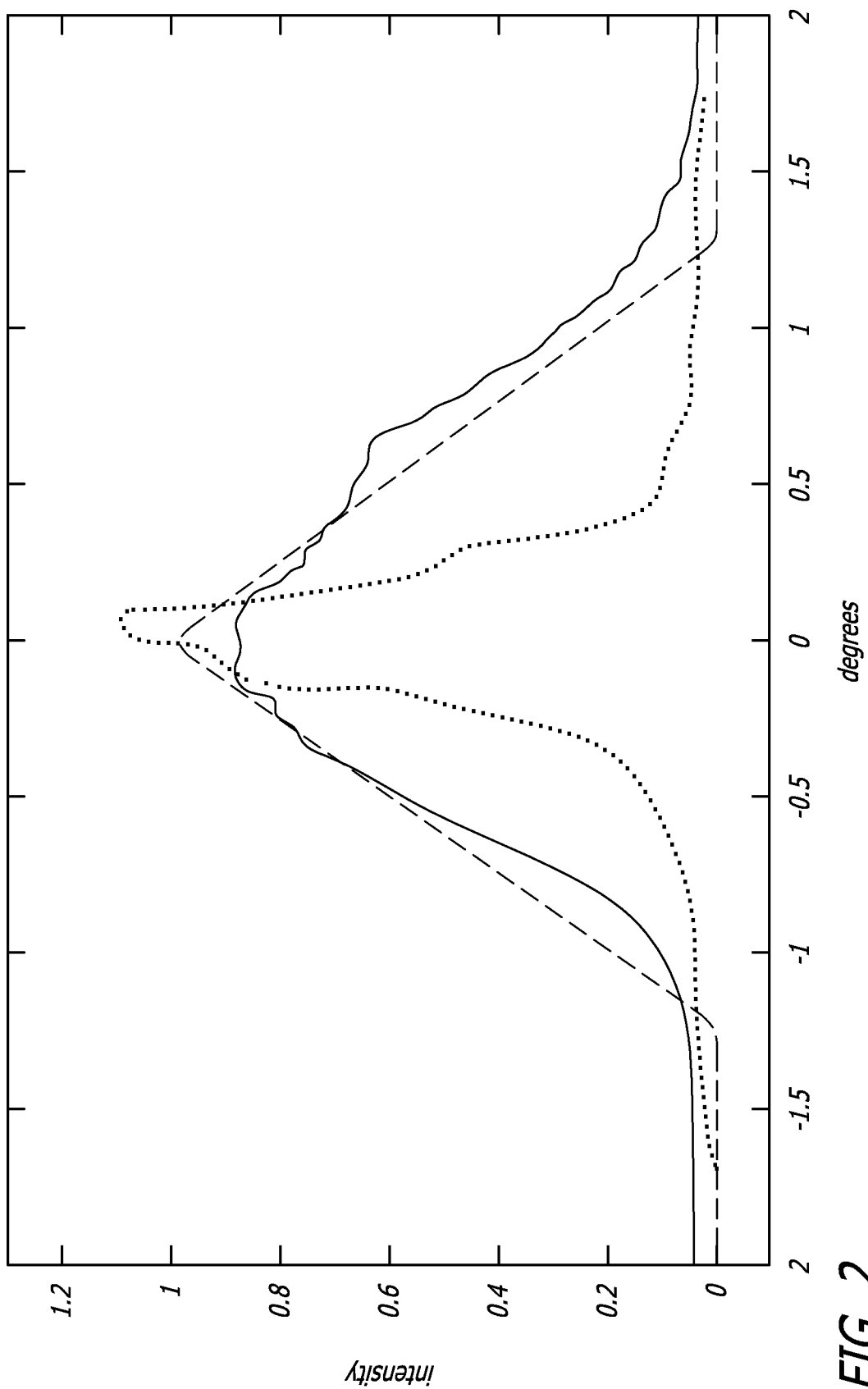

FIG. 2

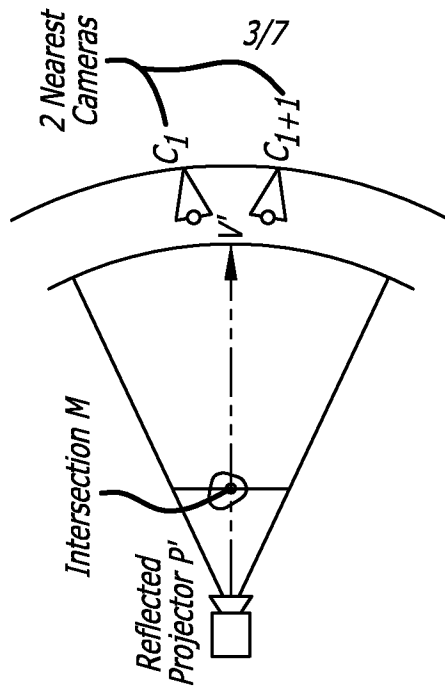

FIG. 3A

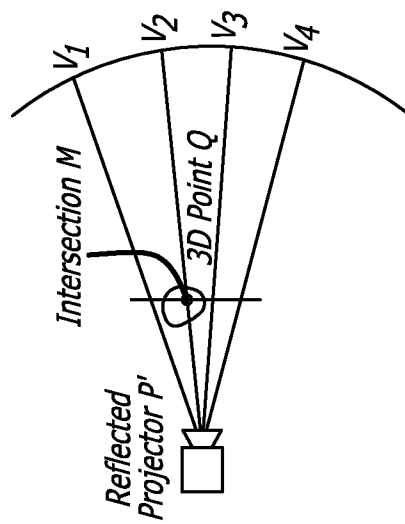

FIG. 3B

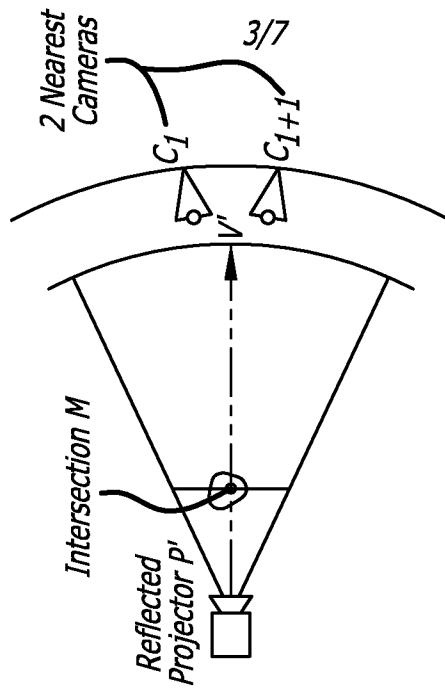

FIG. 3C

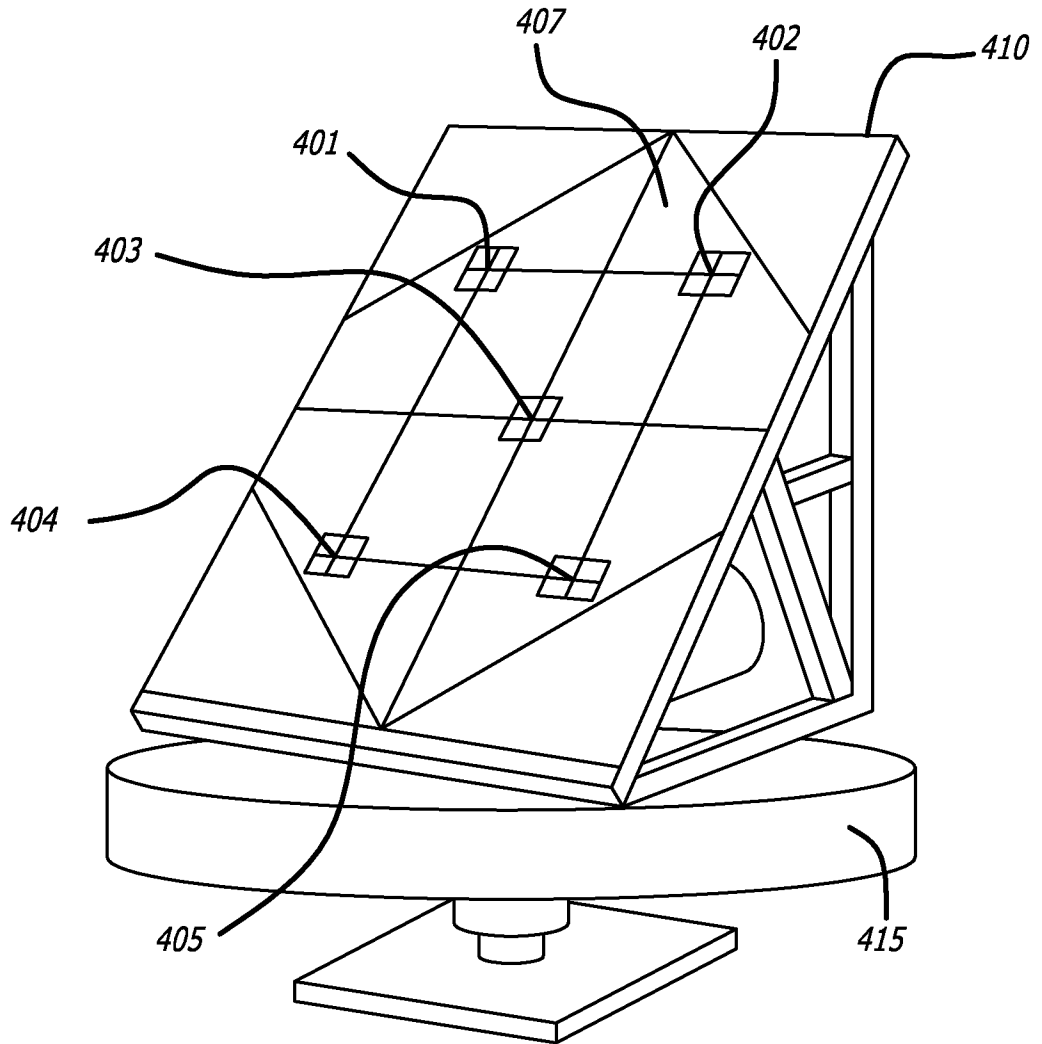

FIG. 4

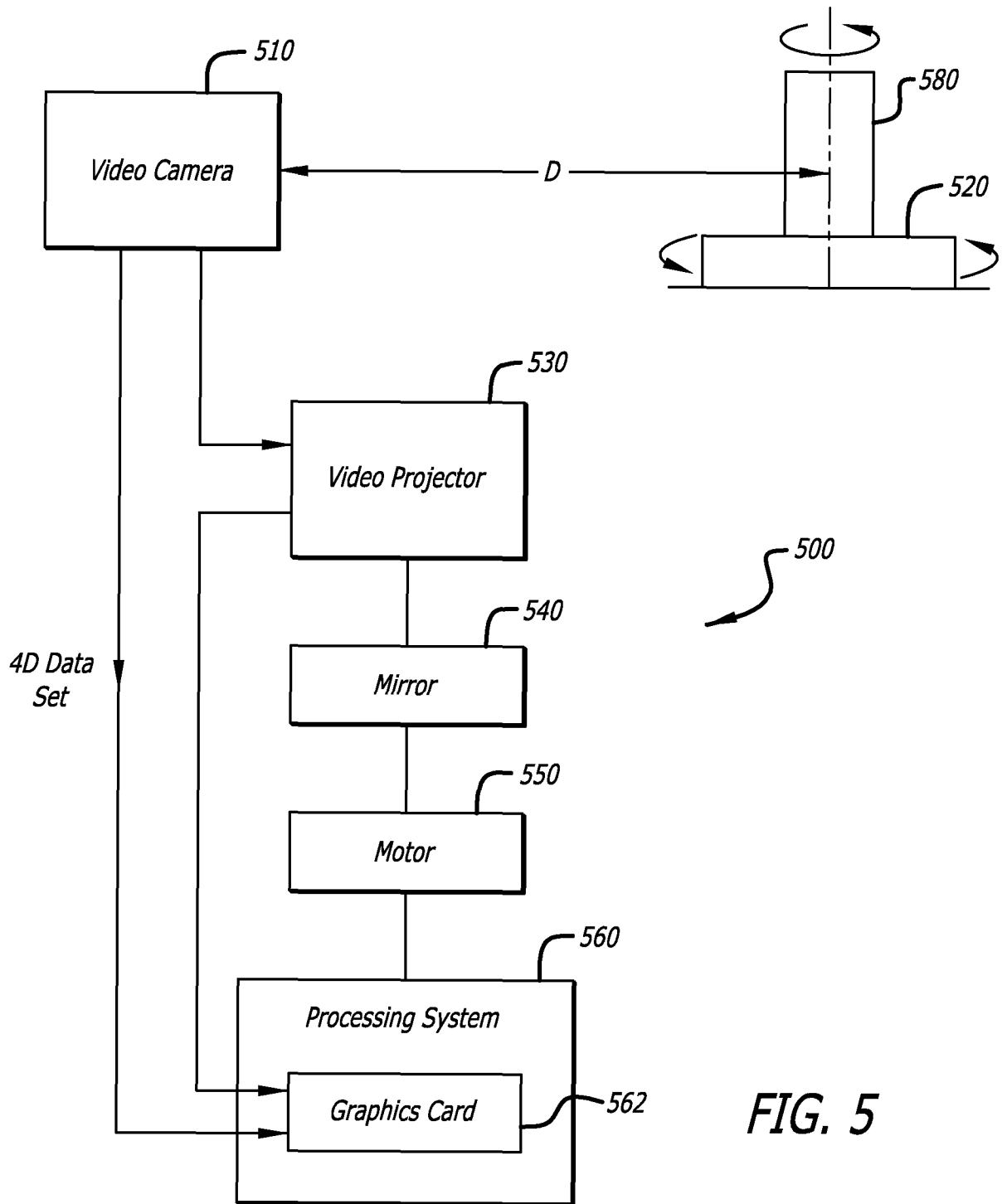

FIG. 5

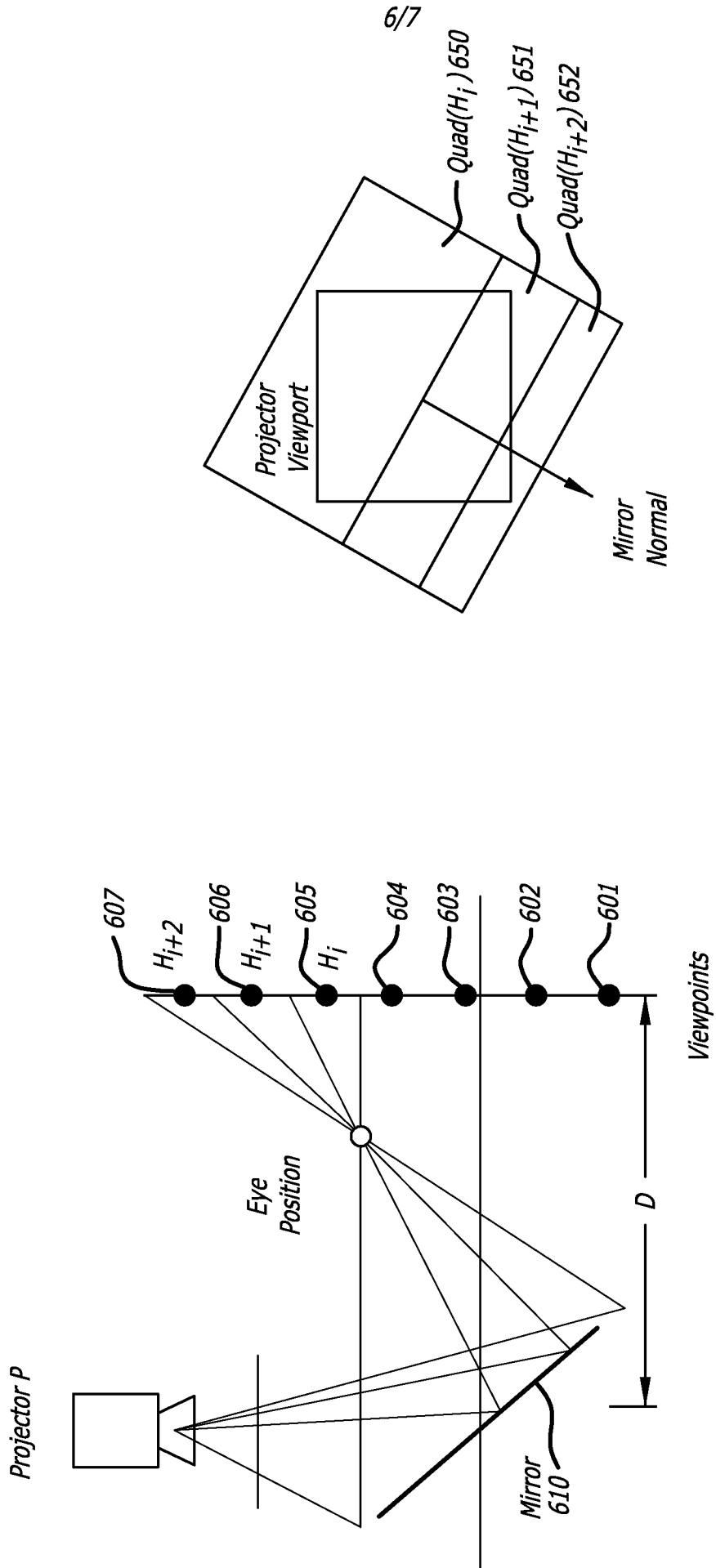
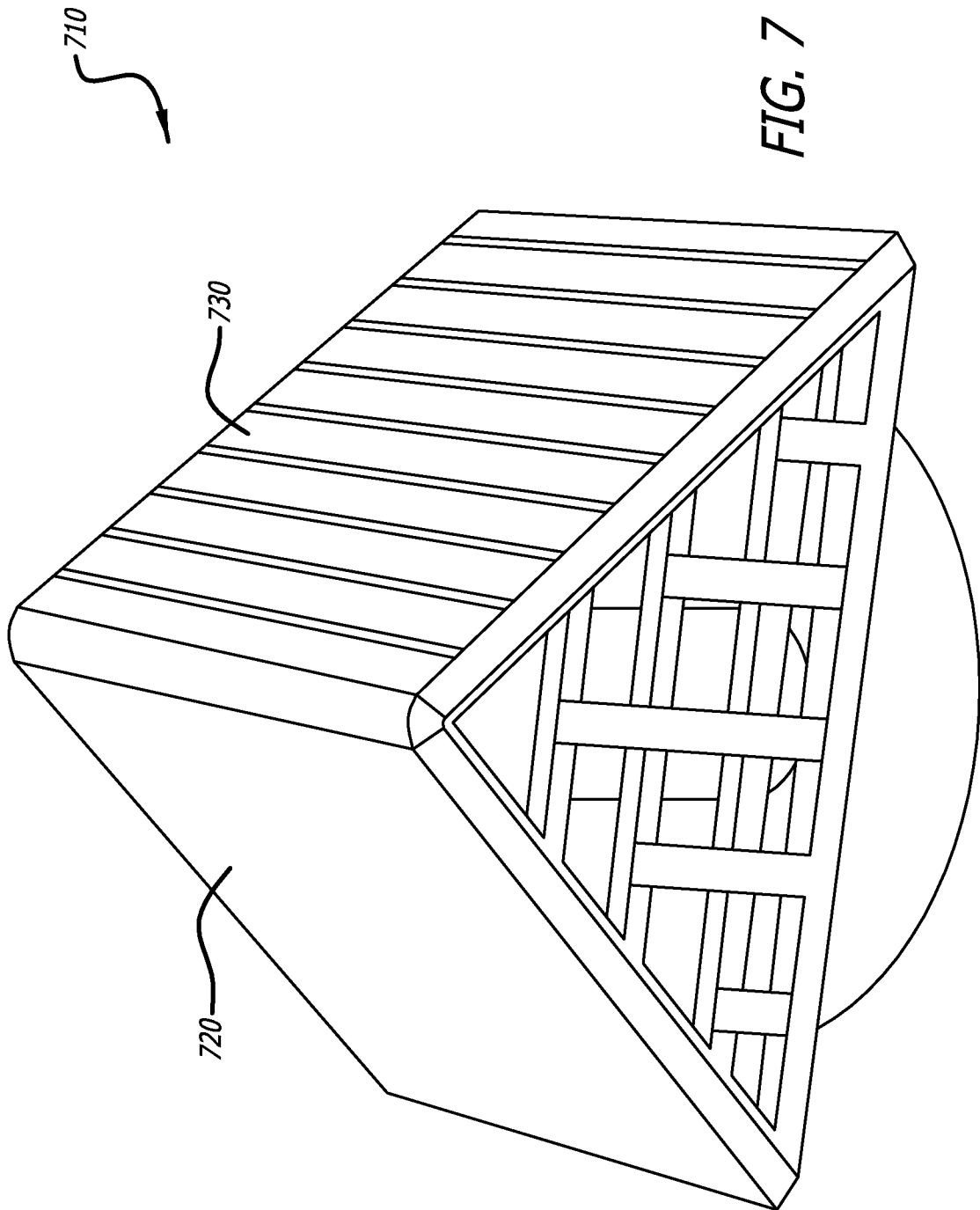

FIG. 6B

FIG. 6A



INTERNATIONAL SEARCH REPORT

International application No.

PCT/US 08/60658

A. CLASSIFICATION OF SUBJECT MATTER
 IPC(8) - G03B 21/60 (2008.04)
 USPC - 359/458
 According to International Patent Classification (IPC) or to both national classification and IPC

B. FIELDS SEARCHED

Minimum documentation searched (classification system followed by classification symbols)
 IPC(8) - G03B 21/60 (2008.04)
 USPC - 359/458

Documentation searched other than minimum documentation to the extent that such documents are included in the fields searched
 USPC - 359/458, 1, 462-477, 353/7 (text search), IPC(8) - G03B 21/60 (2008.04) (text search)

Electronic data base consulted during the international search (name of data base and, where practicable, search terms used)
 PubWest (PGPB, USPT, EPAB, JPAB), freepatentsonline.com, Google, Search terms used: anisotropic, three-dimension, 3d, three, dimension, 3-dimension, 3, dimension, mirror, motor, spin, holographic, diffuser, lenticular, lenslet, array, image, project, magnet

C. DOCUMENTS CONSIDERED TO BE RELEVANT

Category*	Citation of document, with indication, where appropriate, of the relevant passages	Relevant to claim No.
Y	US 2006/0256302 A1 (Hsu) 16 November 2006 (16.11.2006), entire document, especially: Fig. 7, para [0002], [0014], [0015], [0020]-[0028], [0031]-[0035], [0078], [0083]	1-22
Y	US 2003/0214633 A1 (Roddy et al.) 20 November 2003 (20.11.2003), Fig. 7, para [0078], [0083]	1-14
Y	US 5,365,370 A (Hudgins) 15 November 1994 (15.11.1994), col. 5, ln. 35-53	11-13, 15, 16
Y	US 5,870,220 A (Migdal et al.) 09 February 1999 (09.02.1999), Fig. 1, col. 4, ln. 1-22, col. 4, ln. 57 to col. 5, ln. 9, col. 5, ln. 31-42, col. 6, ln. 44-63	17-22

Further documents are listed in the continuation of Box C.

* Special categories of cited documents:	"T" later document published after the international filing date or priority date and not in conflict with the application but cited to understand the principle or theory underlying the invention
"A" document defining the general state of the art which is not considered to be of particular relevance	"X" document of particular relevance; the claimed invention cannot be considered novel or cannot be considered to involve an inventive step when the document is taken alone
"E" earlier application or patent but published on or after the international filing date	"Y" document of particular relevance; the claimed invention cannot be considered to involve an inventive step when the document is combined with one or more other such documents, such combination being obvious to a person skilled in the art
"L" document which may throw doubts on priority claim(s) or which is cited to establish the publication date of another citation or other special reason (as specified)	"&" document member of the same patent family
"O" document referring to an oral disclosure, use, exhibition or other means	
"P" document published prior to the international filing date but later than the priority date claimed	

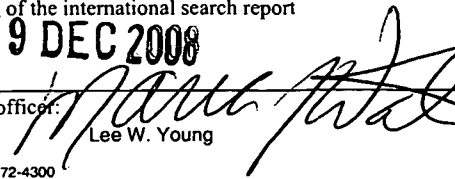
Date of the actual completion of the international search 23 November 2008 (23.11.2008)	Date of mailing of the international search report 09 DEC 2008
Name and mailing address of the ISA/US Mail Stop PCT, Attn: ISA/US, Commissioner for Patents P.O. Box 1450, Alexandria, Virginia 22313-1450 Facsimile No. 571-273-3201	Authorized officer:  Lee W. Young PCT Helpdesk: 571-272-4300 PCT OSP: 571-272-7774