



- (51) International Patent Classification:  
G03F 7/20 (2006.01)
- (21) International Application Number:  
PCT/JP2012/066823
- (22) International Filing Date:  
25 June 2012 (25.06.2012)
- (25) Filing Language: English
- (26) Publication Language: English
- (30) Priority Data:  
61/500,714 24 June 2011 (24.06.2011) US  
13/526,994 19 June 2012 (19.06.2012) US
- (71) Applicant (for all designated States except US): NIKON CORPORATION [JP/JP]; 12-1, Yurakucho 1-chome, Chiyoda-ku, Tokyo, 1008331 (JP).
- (72) Inventor; and
- (75) Inventor/Applicant (for US only): BINNARD, Mike [JP/JP]; c/o NIKON CORPORATION, 12-1, Yurakucho 1-chome, Chiyoda-ku, Tokyo, 1008331 (JP).
- (74) Agent: TATEISHI, Atsuji; TATEISHI & CO., Karakida Center Bldg., 1-53-9, Karakida, Tama-shi, Tokyo, 2060035 (JP).

- (81) Designated States (unless otherwise indicated, for every kind of national protection available): AE, AG, AL, AM, AO, AT, AU, AZ, BA, BB, BG, BH, BR, BW, BY, BZ, CA, CH, CL, CN, CO, CR, CU, CZ, DE, DK, DM, DO, DZ, EC, EE, EG, ES, FI, GB, GD, GE, GH, GM, GT, HN, HR, HU, ID, IL, IN, IS, JP, KE, KG, KM, KN, KP, KR, KZ, LA, LC, LK, LR, LS, LT, LU, LY, MA, MD, ME, MG, MK, MN, MW, MX, MY, MZ, NA, NG, NI, NO, NZ, OM, PE, PG, PH, PL, PT, QA, RO, RS, RU, RW, SC, SD, SE, SG, SK, SL, SM, ST, SV, SY, TH, TJ, TM, TN, TR, TT, TZ, UA, UG, US, UZ, VC, VN, ZA, ZM, ZW.
- (84) Designated States (unless otherwise indicated, for every kind of regional protection available): ARIPO (BW, GH, GM, KE, LR, LS, MW, MZ, NA, RW, SD, SL, SZ, TZ, UG, ZM, ZW), Eurasian (AM, AZ, BY, KG, KZ, RU, TJ, TM), European (AL, AT, BE, BG, CH, CY, CZ, DE, DK, EE, ES, FI, FR, GB, GR, HR, HU, IE, IS, IT, LT, LU, LV, MC, MK, MT, NL, NO, PL, PT, RO, RS, SE, SI, SK, SM, TR), OAPI (BF, BJ, CF, CG, CI, CM, GA, GN, GQ, GW, ML, MR, NE, SN, TD, TG).

Published: — with international search report (Art. 21(3))

(54) Title: METHOD AND APPARATUS TO ALLOW A PLURALITY OF STAGES TO OPERATE IN CLOSE PROXIMITY

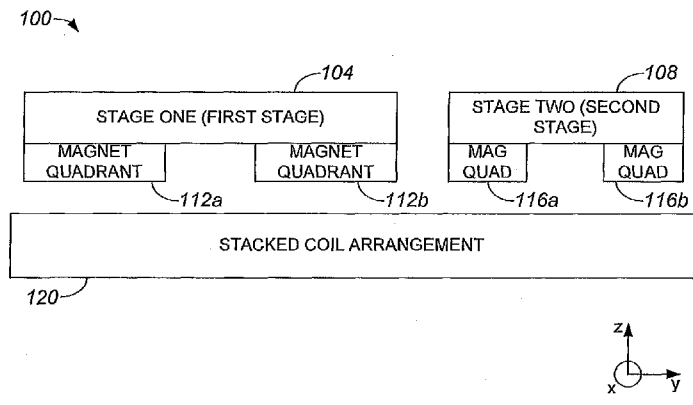

FIG. 1

(57) Abstract: According to one aspect of the present invention, a stage apparatus includes a first stage (104), a first magnet arrangement (112a, 112b), and a stator arrangement (120) that includes a first coil having a first width. The first magnet arrangement is associated with the first stage, and includes a first quadrant (112a) and a second quadrant (112b) or, more generally, a first sub-array and a second sub-array. The first quadrant has at least one first magnet arranged parallel to a first axis, and the second quadrant has at least one second magnet arranged parallel to a second axis. The first quadrant is adjacent to the second quadrant relative to the first axis, and is spaced apart from the second quadrant by a distance relative to the second axis. The stator arrangement is configured to cooperate with the first magnet arrangement to drive the first stage.

WO 2012/176941 A1

## Description

### Title of Invention

**METHOD AND APPARATUS TO ALLOW A PLURALITY OF STAGES  
5 TO OPERATE IN CLOSE PROXIMITY**

### Technical Field

The present invention relates generally to equipment used in semiconductor processing. More particularly, the  
10 present invention relates to a configuration for magnets and/or coils of a planar motor that allows two stages of an overall stage apparatus to operate close together.

### Background Art

15 Many stage apparatus include stages which would benefit from operating in close proximity to each other. For example, in a lithography system such as an immersion lithography system, the ability for two stages, as for example two wafer stages or a wafer stage and a measurement  
20 stage, to operate in close proximity to each other enhances the performance of the system.

Stages that are part of a lithography system, e.g., moving magnet stages, generally utilize linear or planar motors to drive the stages. A linear or planar motor  
25 typically includes a mover and a stator, one of which contains an array of coils and the other of which contains an array of permanent magnets. "Moving coil" generally refers to motors where the mover contains the coil array and the stator contains the magnet array. "Moving magnet"

generally refers to motors where the stator contains the coil array and the mover contains the magnet array. In a stage driven by a moving magnet planar motor, magnets mounted on the stage may be oriented such that some magnets, e.g., X magnets, of a substantially continuous array are oriented to create a force in at least an X direction, and other magnets, e.g., Y magnets, of the array are oriented to create a force in at least a Y direction. A stator may include some coils oriented to produce force in at least an X direction, e.g., X coils, and other coils oriented to produce force in at least a Y direction, e.g., Y coils. The magnets and the stator are generally effective in generating desired forces, e.g., a desired force in an X direction may be generated when an appropriate X magnet interacts with an X coil, additional forces, normally of a smaller magnitude, that are not desired may also be generated.

When two stages of a lithography system are relatively close to one another, while a desired force may be generated to drive one stage, undesired forces may also be generated that have an adverse effect on the other stage. In other words, when two stages are driven by a moving magnet planar motor system, in generating a desired force to drive one stage, disturbance forces that have a relatively significant adverse effect on the other stage may be created. To avoid generating such disturbance forces, the two stages may be spaced further apart, thereby impacting the ability for the two stages to operate close together.

### **Summary of Invention**

The present invention pertains to a moving magnet planar motor arrangement that includes stacked coils and/or magnet arrays that include quadrants of magnets which are spaced apart. Such a moving magnet planar motor arrangement  
5 allows two stages to operate relatively close together in a lithography system such as an immersion lithography system. It should be appreciated that spacing quadrants of magnets apart on a stage may be beneficial to facilitate the accurate control of a substantially single stage.

10 According to one aspect of the present invention, a stage apparatus includes a first stage, a first magnet array, and a stator arrangement. The first magnet array is associated with the first stage. The stator arrangement cooperates with the first magnet array to drive the first  
15 stage, and includes a plurality of coils. The plurality of coils includes a first coil of a first type and a second coil of a second type where the first coil is stacked over the second coil, and a third coil of the first type and a fourth coil of the second type where the fourth coil is  
20 stacked over the third coil. The first and fourth coils are in a first plane, and the second and third coils are in a second plane. In one embodiment, the first coil is stacked over the second coil and supports a force in a first direction along a first axis while the second coil supports  
25 a force in a second direction along a second axis.

In accordance with another aspect of the present invention, a stage apparatus includes a first stage, a first magnet arrangement, and a stator arrangement that includes a first coil having a first width. The first magnet

arrangement is associated with the first stage, and includes a first quadrant and a second quadrant or, more generally, a first sub-array and a second sub-array. The first quadrant has at least one first magnet arranged parallel to a first axis, and the second quadrant has at least one second magnet arranged parallel to a second axis. The first quadrant is adjacent to the second quadrant relative to the first axis, and is spaced apart from the second quadrant by a distance relative to the second axis. The stator arrangement is configured to cooperate with the first magnet arrangement to drive the first stage. In one embodiment, the first magnet arrangement is a linear magnet array, and the first quadrant is arranged to cooperate with the stator arrangement to generate a first force along the second axis while the second quadrant is arranged to cooperate with the stator arrangement to generate a second force along the first axis.

According to yet another aspect of the present invention, a stage apparatus includes a first stage, a second stage, a first magnet array, a second magnet array, and a stator arrangement. The first magnet array is associated with the first stage, and includes a first quadrant having at least one first magnet and a second quadrant having at least one second magnet. The first quadrant is arranged to produce a force in a first direction and the second quadrant is arranged to produce a force in a second direction. The second magnet array is associated with the second stage, and includes a third quadrant having at least one third magnet and fourth quadrant having at least one fourth magnet. The third quadrant is arranged to

produce a force in the first direction, while the fourth quadrant is arranged to produce a force in the second direction. The stator arrangement includes at least one coil, and cooperates with the first magnet array to drive the first stage as well as with the second magnet array to drive the second stage. When the fourth quadrant is approximately adjacent to the first quadrant, the second stage may move in closer proximity to the first stage than when the third quadrant is approximately adjacent to the first quadrant.

### **Brief Description of Drawings**

FIG. 1 is a diagrammatic representation of a stage arrangement which includes a planar motor having a stacked coil arrangement and magnet arrays with sub-arrays, e.g., quadrants, of magnets that are spaced apart in accordance with an embodiment of the present invention.

FIG. 2A is a diagrammatic representation of a stage arrangement which includes a planar motor having a stacked coil arrangement in which X coils are stacked on top of Y coils, and magnet arrays with quadrants of magnets that are spaced apart in accordance with an embodiment of the present invention.

FIG. 2B is a diagrammatic representation of a stage arrangement which includes a planar motor having a stacked coil arrangement in which Y coils are stacked on top of X coils, and magnet arrays with quadrants of magnets that are spaced apart in accordance with an embodiment of the present invention.

FIG. 2C is a diagrammatic representation of a stage arrangement which includes a planar motor having a stacked coil arrangement in which some X coils are stacked on top of some Y coils and other Y coils are stacked on top of X coils,  
5 and magnet arrays with quadrants of magnets that are spaced apart in accordance with an embodiment of the present invention.

FIG. 3A is a diagrammatic representation of quadrants of magnets associated with magnet arrays of two stages in  
10 which a coil arranged to generate an X force is aligned with a quadrant of X magnets and a quadrant of Y magnets at a time  $t_1$  in accordance with an embodiment of the present invention.

FIG. 3B is a diagrammatic representation of quadrants  
15 of magnets associated with magnet arrays of two stages in which a coil arranged to generate an X force, e.g., coil 336 of FIG. 3A, is aligned with an empty space between a quadrant of X magnets and a quadrant of Y magnets at a time  $t_2$  in accordance with an embodiment of the present invention.

FIG. 3C is a diagrammatic representation of quadrants  
20 of magnets associated with magnet arrays of two stages in which a coil arranged to generate an X force, e.g., coil 336 of FIG. 3A, is aligned with a quadrant of X magnets and a quadrant of Y magnets at a time  $t_3$  in accordance with an  
25 embodiment of the present invention.

FIG. 4 is a diagrammatic representation of a stage arrangement that includes a plurality of stages each having quadrants of magnets in accordance with an embodiment of the present invention.

FIG. 5 is a diagrammatic representation of a planar motor with a stacked coil arrangement in accordance with an embodiment of the present invention.

FIG. 6A is a diagrammatic representation of a first magnet array suitable for use in a measurement stage or a tube carrier in accordance with an embodiment of the present invention.

FIG. 6B is a diagrammatic representation of a second magnet array suitable for use in a measurement stage or a tube carrier in accordance with an embodiment of the present invention.

FIG. 6C is a diagrammatic representation of a third magnet array suitable for use in a measurement stage or a tube carrier in accordance with an embodiment of the present invention.

FIG. 6D is a diagrammatic representation of a fourth magnet array suitable for use in a measurement stage or a tube carrier in accordance with an embodiment of the present invention.

FIG. 7 is a diagrammatic representation of a photolithography apparatus in accordance with an embodiment of the present invention.

FIG. 8 is a process flow diagram which illustrates the steps associated with fabricating a semiconductor device in accordance with an embodiment of the present invention.

FIG. 9 is a process flow diagram which illustrates the steps associated with processing a wafer, *i.e.*, step 1104 of FIG. 8, in accordance with an embodiment of the present invention.

FIG. 10 is a diagrammatic representation of force directions associated with the positioning of an X coil over an X magnet array in accordance with an embodiment of the present invention.

5 FIG. 11 is a diagrammatic representation of force directions associated with the positioning of an X coil over a Y magnet array in accordance with an embodiment of the present invention.

10 FIG. 12 is a diagrammatic representation of flux directions and force directions associated with the positioning of an X coil over an X magnet array in accordance with an embodiment of the present invention.

15 FIG. 13 is a diagrammatic representation of flux directions and force directions associated with the positioning of a Y coil over an X magnet array in accordance with an embodiment of the present invention.

FIG. 14 is a diagrammatic representation of a moving magnet planar motor coil array and a magnet array in accordance with an embodiment.

20 FIG. 15 is a diagrammatic representation of a magnet array that is of a substantially minimum size configuration that is suitable for use with a moving magnet planar motor coil array in accordance with an embodiment.

25 FIG. 16 is a diagrammatic representation which schematically shows an arrangement of an immersion type exposure apparatus, in accordance with an embodiment.

FIG. 17 is a planar view representing an arrangement of a wafer stage assembly, especially an arrangement of magnet units (magnets) within a wafer stage and a

measurement stage that structure a stage mover assembly (planar motor), and an arrangement of coil units (armature coils) within a base member in accordance with an embodiment.

FIG. 18A is a cross section view along line A-A in FIG. 17, and FIG. 18B is a cross section view along line B-B in FIG. 17 in accordance with an embodiment.

FIG. 19 is a block diagram which illustrates an input/output relation of a control system that mainly structures a control system of the exposure apparatus in FIG. 16 in accordance with an embodiment.

FIGS. 20A to 20D are a series of diagrammatic representations used to describe a scrub operation between a wafer stage and a measurement stage in accordance with an embodiment.

FIG. 21 is a diagrammatic representation of a positional relation between Y magnet units structuring a mover within a wafer stage and a measurement stage and armature coils (Y coil units) which are excited when both stages are proximate in accordance with an embodiment.

FIG. 22 is a diagrammatic representation when a wafer stage and a measurement stage are proximate, of a positional relation between X magnet units structuring a mover within both stages and armature coils (X coil units) which are excited in accordance with an embodiment.

25

### **Description of Embodiments**

Example embodiments are discussed below with reference to the various figures. However, those skilled in the art will readily appreciate that the detailed description given

herein with respect to these figures is for explanatory purposes, as the invention extends beyond these embodiments.

A stage that includes a magnet array with sub-arrays, e.g., quadrants, that are spaced apart in one direction, e.g., an X direction or a Y direction, effectively ensures  
5 that coil groups that are part of a stator arrangement which cooperates with the magnet array to drive the stage will make a relatively strong force with magnets in substantially only one quadrant at any given time. In other words,  
10 spacing between quadrants of a magnet array effectively prevents a coil from producing a substantial force with more than one quadrant at a time. It should be appreciated that although quadrants of magnets are described for ease of discussion, magnets are not limited to being divided into  
15 four quadrants and may generally be divided into any number of sub-arrays.

Within an overall stage system that utilizes more than one stage, as for example within an immersion lithography system in which a wafer stage may move together with a  
20 measurement stage having various sensors or measurement tools and/or a tube carrier stage supporting tubes or pipes connected to the wafer stage, or in a system in which two wafer stages periodically move together, arranging magnet arrays associated with the stages such that a quadrant of  
25 one stage that has a particular magnetic orientation is approximately adjacent to a quadrant of a second stage that has a substantially perpendicular magnetic orientation allows the two stages to operate in close proximity. For example, positioning a quadrant of magnets of a wafer stage

that are arranged to make a force in an X direction, *i.e.*, an "X quadrant," approximately adjacent to a quadrant of magnets of a measurement stage, a tube carrier stage, or another wafer stage that are arranged to make force in a Y direction, *i.e.*, a "Y quadrant," allows the two stages to operate in relatively close proximity because energized X coils that overlap both stages will make a substantial force with the X quadrant of the first stage, but will not interact strongly with the Y quadrant of the second stage. Similarly, energized Y coils that overlap both stages will make a substantial force with the Y quadrant of the second stage, but will not interact strongly with the X quadrant of the first stage.

In one embodiment, a stator that is a part of a planar motor may include a stacked coil arrangement. A stacked coil arrangement is a configuration of coils in which a substantially uniform layer of X coils may be stacked on top of a substantially uniform layer of Y coils, and/or vice versa. The stacking of coils provides a stator within which substantially every location within the stator has an X coil and a Y coil.

Referring initially to FIG. 1, a stage arrangement which includes a planar motor having a stacked coil arrangement and magnets arrays with quadrants of magnets that are spaced apart will be described in accordance with an embodiment of the present invention. It should be appreciated that although a stage arrangement 100 of FIG. 1 is shown as including a stacked coil arrangement and magnet arrays with quadrants of magnets that are spaced apart,

stage arrangement 100 may instead include either a stacked coil arrangement or magnet arrays with quadrants of magnets that are spaced apart.

Stage arrangement 100 includes a first stage 104 and a  
5 second stage 108. In one embodiment, first stage 104 may be a wafer stage and second stage 108 may be a measurement stage, a tube carrier stage, or another wafer stage 108. In general, stage 108 may be any type of stage. Although stage 108 may be any type of stage, stage 108 will be referred to  
10 as a measurement stage for ease of discussion. Wafer stage 104 and measurement stage 108 are oriented above a stacked coil arrangement 120 which includes X coils (not shown), e.g., coils arranged to generate a force in an X direction and Y coils (not shown), e.g., coils arranged to generate a  
15 force in a Y direction, that are stacked with respect to a Z direction. It should be appreciated, however, that in some applications, a stage arrangement such as stage arrangement 100 may be oriented differently with relative to gravity, as for example upside down or vertically, e.g., with gravity  
20 acting in an X direction or a Y direction. Wafer stage 104 is coupled to a magnet array that includes magnet quadrants 112a, 112b arranged to cooperate with stacked coil arrangement 120 to operate as a planar motor to drive wafer stage 104. Measurement stage 108 is coupled to a magnet  
25 array that includes magnet quadrants 116a, 116b arranged to also cooperate with stacked coil arrangement 120 to operate as a planar motor to drive measurement stage 108.

As shown, magnet quadrant 112a is spaced apart along, or relative to, a y-axis from magnet quadrant 112b, and

magnet quadrant 116a is spaced apart along the y-axis from magnet quadrant 116b. The amount by which magnet quadrant 112a is spaced apart from magnet quadrant 112b, and the amount by which magnet quadrant 116a is spaced apart from magnet quadrant 116b, may vary. In one embodiment, the amount by which magnet quadrant 112a is spaced apart from magnet quadrant 112b and the amount by which magnet quadrant 116a is spaced apart from magnet quadrant 116b may be greater than or approximately equal to a length of a coil (not shown) that is included in stacked coil arrangement 120 in a Y direction. It should be appreciated that in some embodiments, magnet quadrants may be spaced apart by the longer of a width or a length of a coil.

Stacked coil arrangement 120 generally includes at least one X coil (not shown) arranged to cooperate with X magnets (not shown), or magnets included in magnet quadrants 112a, 112b, 116a, 116b which oriented to create a force in an X direction, and at least one Y coil arranged to cooperate with Y magnets (not shown), or magnets included in magnet quadrants 112a, 112b, 116a, 116b which are oriented to create a force in an Y direction. Stacked coil arrangement 120 preferably includes uniform layers of coils (not shown), and the uniform layer of coils may preferably be arranged in substantially rectangular or square groups of coils. In other words, stacked coil arrangement 120 is configured such that at substantially every location within stacked coil arrangement along at least an x-axis, stacked coil arrangement 120 includes an X coil (not shown) and a Y coil (not shown). With respect to FIGS. 2A-C, different

configurations of coils within a stacked coil arrangement, e.g., a stacked coil arrangement of a stator, will be described in accordance with an embodiment of the present invention. In one embodiment, as shown in FIG. 2A, within a stage arrangement 200' that includes a stacked coil arrangement 120', X coils 120a may be stacked on top of Y coils 120b. X coils 120a are stacked on top of Y coils 120b such that X coils 120a are closer to magnet quadrants 112a, 112b, 116a, 116b than Y coils 120b. When X coils 120a are closer to magnet quadrants 112a, 112b, 116a, 116b relative to a z-axis than Y coils 120b, X coils 120a typically operate with better efficiency than Y coils 120b.

When X coils 120a are stacked on top of Y coils 120b, X coils 120a are positioned substantially over Y coils 120b with respect to a z-axis. It should be appreciated that although X coils 120a may be in contact with Y coils 120b, X coils 120a may instead be positioned such that there is a slight gap between coils 120a and Y coils 120b with respect to a z-axis.

When a system is such that efficiency associated with Y coils is more important than efficiency associated with X coils, Y coils may be stacked on top of X coils. FIG. 2B is a diagrammatic representation of a stage arrangement which includes a planar motor having a stacked coil arrangement in which Y coils are stacked on top of X coils in accordance with an embodiment. A stage arrangement 200" includes a stacked coil arrangement 120" that has Y coils 120b stacked on top of X coils 120a such that Y coils 120b are in closer proximity to magnet quadrants 112a, 112b, 116a, 116b than X

coils 120a. Thus, Y coils 120b operate with better efficiency than X coils 120a due to coils 120b being closer to magnet quadrants 112a, 112b, 116a, 116b relative to a z-axis than X coils 120a.

5 In one embodiment, a stacked coil arrangement of a stator may be such that some areas of the stacked coil arrangement have X coils stacked on top of Y coils, while other areas of the stacked coil arrangement have Y coils stacked on top of X coils. FIG. 2C is a diagrammatic  
10 representation of a stage arrangement which includes a planar motor having a stacked coil arrangement in which some X coils are stacked on top of some Y coils and other Y coils are stacked on top of X coils in accordance with an  
15 embodiment. A stage arrangement 200'' includes a stacked coil arrangement 120'' having a plurality of X coils 120a and a plurality of Y coils 120b. Along an x-axis, X coils 120a and Y coils 120b are arranged as coil pairings in which at least one X coil 120a is positioned on top of at least one Y coil 120b and at least one Y coil 120b is positioned  
20 on top of at least one X coil 120a. In areas in which X coils 120a are positioned on top of Y coils 120b, X coils 120a may operate with better efficiency than Y coils 120b. Alternatively, in areas in which Y coils 120b are positioned on top of X coils 120a, Y coils 120b operate with better  
25 efficiency than X coils 102a. In one embodiment, if the coil pairings are sufficiently small compared to the size of the magnet arrays, an arrangement where half of the coil pairings have X coils 120a positioned on top of Y coils 120b

may provide substantially equal efficiency for both X and Y coils.

As previously mentioned, a magnet array that is substantially divided or otherwise segregated into quadrants  
5 may be such that the quadrants are spaced apart in at least one direction, as for example along an x-axis. Providing spacing within a magnet array may effectively ensure that coil groups may cooperate with magnets of substantially only one quadrant of the magnet array to generate a relatively  
10 strong force. When a plurality of energized X coils and a quadrant of magnets extending in a Y direction overlap, e.g., an XZ quadrant, substantially independently controlled forces may generated in an X direction and in a Z direction. The presence of a space between quadrants of magnets is  
15 effectively an area that enables an energized coil, e.g., an energized X coil, and the space to overlap substantially without resulting in the generation of any forces.

FIG. 3A is a diagrammatic representation of quadrants of magnets associated with magnet arrays of two stages in  
20 which a coil arranged to generate an X force is aligned with a quadrant of X magnets and a quadrant of Y magnets at a time  $t_1$  in accordance with an embodiment of the present invention. A magnet array 306 associated with a first stage includes quadrants of magnets 312a, 312b, and a magnet array  
25 310 associated with a second stage, e.g., a second stage that periodically operates in close proximity to a first stage or "scrums" with a first stage, includes quadrants of magnets 316a, 316b. When a second stage is in a scrum stage with a first stage, the two stages may come relatively close

together in a synchronized manner to maintain a relatively small separation therebetween. Each quadrant 312a, 312b, 316a, 316b is configured to provide vertical forces, *i.e.*, forces in a Z direction, along with horizontal forces that are perpendicular to the axis of magnets included in each quadrant 312a, 312b, 316a, 316b.

As shown, a substantially empty space 328, *i.e.*, a space in which magnets are not positioned, is included between quadrants 312a, 312b along an x-axis, while a substantially empty space 332 is included between quadrants 316a, 316b along the x-axis. Empty space 328 is arranged to substantially separate quadrants 312a from substantially adjacent quadrants 312b along the x-axis. Similarly, empty space 332 is arranged to substantially separate quadrants 316a from substantially adjacent quadrants 316b along the x-axis.

Quadrants of magnets 312a, 316a include X magnets, or magnets which are arranged to provide force in an X direction, while quadrants of magnets 312b, 316b include Y magnets, or magnets which are arranged to provide force in a Y direction. That is, quadrants of magnets 312a, 316a are of an X orientation while quadrants of magnets 312b, 316b are of a Y orientation. In one embodiment, a quadrant 312a which is of an X orientation is effectively adjacent to a quadrant 316b which is of a Y orientation, and a quadrant 312b which is of a Y orientation is effectively adjacent to a quadrant 316a which is of an X orientation. It should be appreciated that X magnets are generally arranged parallel to a y-axis, while Y magnets are generally arranged parallel

to an x-axis. In the embodiment as shown, each quadrant of magnets 312a, 316a includes X magnets and not Y magnets, while each quadrant of magnets 312b, 316b includes Y magnets and not X magnets.

5           Quadrants of magnets 312a, 316a are configured to cooperate with a coil 336a to provide force in an X direction, and quadrants of magnets 312b, 316b are configured to cooperate with a coil 336b to provide force in a Y direction. Coil 336a is an X coil and coil 336b is a Y  
10 coil that are both part of a stator (not shown) that is effectively shared by magnet array 306 and magnet array 310, and are arranged to be energized or activated when at least one of coils 336a, 336b fully or partially overlaps with quadrants of magnets 312a and/or quadrants of magnets 316a.

15           As shown, at a time  $t_1$ , coil 336a is arranged such that a part of coil 336a partially overlaps with a quadrant 312b of magnet array 306 and with a quadrant 316a of magnet array 310. When coil 336a is energized, coil 336a cooperates with a quadrant 316a of magnet array 310 to drive  
20 the second stage (not shown) with which magnet array 310 is coupled. Although part of coil 336a also effectively overlaps a quadrant 312b of magnet array 306, because coil 336a is an X coil, the first stage (not shown) with which magnet array 306 is coupled is not driven using coil 336a at  
25 time  $t_1$ . It should be appreciated that at time  $t_1$ , if coil 336b is energized, coil 336b cooperates with a quadrant 312b of magnet array 306 to drive the first stage (not shown) with which magnet array 306 is coupled. In one embodiment, coil 336b is located substantially underneath coil 336a.

In the embodiment as shown, along an x-axis, coil 336a has a coil width C and coil 336b has a coil length L, while empty spaces 328, 336 have a width W. Width W is typically selected to be greater than or approximately equal to coil length L, and is also greater than or approximately equal to coil width C. By selecting width W to be greater than or approximately equal to coil width C, coil 336a will not overlap two quadrants 312a at the same time. Similarly, when width W is greater than or approximately equal to coil width C, coil 336a also will not overlap two quadrants 316a at the same time. In addition, coil 336a will not overlap a quadrant 312a and a quadrant 316a at the same time.

By selecting width W to be greater than or approximately equal to coil length L, coil 336b will not overlap two quadrants 312b at the same time. Similarly, by selecting width W to be greater than or approximately equal to coil length L, coil 336b also will not overlap two quadrants 316b at the same time. In addition, coil 336b will not overlap both a quadrant 312b and a quadrant 316b at the same time.

When width W is sized to be greater than or approximately equal to coil width C, then force-producing regions associated with each stage (not shown) associated with magnet arrays 306, 310 generally do not overlap, and a substantially minimum operating distance between magnet array 306 and magnet array 310 may be as little as approximately zero millimeters (mm). It should be appreciated that although both empty space 328 and empty space 332 are shown as having the same width W, each empty

space 328, 332 may have different widths with each width being greater or equal to coil width C. It should be appreciated that if the empty space on one stage is wider than the width or length in an X direction of coils 336a, 336b, the stages (not shown) may operate with almost zero spacing between them in a Y direction substantially without precisely following each other in the X direction. Further, the stages are able to move along the Y direction with almost zero spacing between them.

At a time  $t_2$ , coil 336a is positioned such that part of coil 336a overlaps with empty space 328 and part of coil 336a overlaps with empty space 332, as shown in FIG. 3B. Thus, coil 336a is not associated with the generation of any forces at time  $t_2$ . It should be appreciated that when coil 336a is positioned to partially overlap with empty space 328 and with empty space 332, coil 336a may be deactivated.

FIG. 3C is a representation of coils 336a, 336b at a time  $t_3$  in accordance with an embodiment of the present invention. At time  $t_3$ , part of coil 336a overlaps with a quadrant 312a of magnet array 306 and a quadrant 316b of magnet array 310. When coil 336a overlaps with a quadrant 312a, coil 336 and quadrant 312a cooperate to drive the first stage (not shown) associated with magnet array 306.

As mentioned above, a plurality of stages that are included in a system such as an immersion lithography system may include a wafer stage and a second stage which may be a measurement stage, a tube carrier stage, or a second wafer stage. It should be appreciated that a tube carrier stage is a stage that is arranged to support, or otherwise carry,

cables and hoses that supply the wafer stage. In general, the second stage may preferably operate at least some of the time in relatively close proximity to a wafer stage. A second stage may approach relatively close to a wafer stage, 5 in one embodiment, when a quadrant of magnets of the second stage that is arranged to make force in an X direction is substantially adjacent to a quadrant of magnets of the wafer stage that is arranged to make force in a Y direction, and/or vice versa. The force on each quadrant of each stage 10 may generally be independently controlled, as a quadrant arranged to make force in an X direction does not interact strongly with any overlapping Y coils, and a quadrant arranged to make force in a Y direction does not interact strongly with any overlapping X coils.

15 With reference to FIG. 4, a stage arrangement that includes a plurality of stages, e.g., a wafer stage and a measurement stage or a tube carrier stage, each having a magnet array substantially coupled thereon that includes quadrants of magnets will be described in accordance with an 20 embodiment of the present invention. A stage arrangement 400 includes a first magnet array 406 that is substantially coupled to a wafer stage (not shown) and a second magnet array that is 410 that is substantially coupled to a measurement stage (not shown) or a tube carrier stage (not 25 shown).

First magnet array 406, as shown, includes four quadrants 412a, 412b. X quadrants 412a include X magnets (not shown) that are oriented substantially parallel to a y-axis such that the X magnets may cooperate with overlapping

energized X coils (not shown) of a stator (not shown) to generate force in a direction along an x-axis or, more generally in a direction that is substantially perpendicular to the longitudinal axis of the X magnets. Y quadrants 412b  
5 include Y magnets (not shown) that are oriented substantially parallel to an x-axis such that the Y magnets may cooperate with overlapping energized Y coils (not shown) of a stator (not shown) to generate force in a direction along a y-axis or, more generally in a direction that is  
10 substantially perpendicular to the longitudinal axis of the Y magnets. In one embodiment, quadrants 412a, 412b have a pitch that is in a range of between approximately 50 mm and approximately 120 mm, e.g., approximately 60 mm, and first linear magnet array 406 may be approximately 600 mm by  
15 approximately 480 mm. It should be appreciated that quadrants 412a include X magnets (not shown) and do not include Y magnets, while quadrants 412b include Y magnets (not shown) and do not include X magnets.

It should be appreciated that each quadrant 412a, 412b  
20 is capable of producing forces in a direction along a z-axis. That is, each quadrant 412a is arranged to generate X forces and Z forces, while each quadrant 412b is arranged to generate Y forces and Z force.

Quadrants 412a, 412b are substantially separated along  
25 an x-axis by a substantially empty space 428. As described above, the width of empty space 428 along the x-axis may be greater than or approximately equal to the length of a coil (not shown) of a stator (not shown) which cooperates with first linear magnet array 406 to effectively form a planar

motor. In one embodiment, the size of a coil (not shown), e.g., the length of the coil, is a multiple of a pitch of magnets included in quadrants 412a, 412b. For example, when quadrants 412a, 412b, 416a, 416b have a pitch of  
5 approximately 60 mm, a coil length may be approximately twice the pitch at approximately 120 mm and, hence, a width of empty space 428 relative to the x-axis may be approximately twice the pitch at approximately 120 mm. In the embodiment as shown, quadrants 412a, 412b may each be  
10 approximately 240 mm by approximately 240 mm, and substantially empty space 428 included within first linear magnet array 406 may have a width relative to an x-axis of approximately 120 mm.

Second magnet array 410 includes X quadrants 416a  
15 which each include at least one X magnet (not shown) and Y quadrants 416b which each include at least one Y magnet (not shown). While the number of magnets included in each quadrant 416a, 416b may vary, in the described embodiment, quadrants 416a, 416b typically each include between  
20 approximately four and approximately 32 magnets. Quadrants 416a, 416b are spaced apart along an x-axis by a substantially empty space 432. In one embodiment, quadrants 416a, 416b have a pitch that is equal to approximately 60 mm, empty space 432 may have a width along an x-axis of  
25 approximately 120 mm, and second magnet array 410 may be approximately 360 mm by approximately 240 mm. Quadrants 416a, 416b may each be approximately 120 mm by approximately 120 mm.

In order for a measurement stage (not shown) or a tube carrier stage (not shown) that is substantially coupled to second magnet array 410 to move in relatively close proximity to a wafer stage (not shown) that is substantially coupled to first magnet array 406, quadrants 416a, 416b of second magnet array 410 that are substantially adjacent to quadrants 412a, 412b of first magnet array 406 are arranged to be of an opposite orientation. As shown, relative to a y-axis, an X quadrant 412a is substantially adjacent to a Y quadrant 416b, while a Y quadrant 412b is substantially adjacent to an X quadrant 416a. Hence, in one embodiment, a wafer stage (not shown) and a measurement stage (not shown) or a tube carrier stage (not shown) may effectively come into contact with each other. In other words, a substantially minimum operational distance between first magnet array 406 and second magnet array 410 may be approximately zero mm, e.g., a distance  $S$  may be as small as approximately zero mm.

FIG. 5 is a diagrammatic representation of a planar motor that includes a stator with a stacked coil arrangement in accordance with an embodiment of the present invention. A planar motor 564 includes a magnet arrangement 514 that is generally coupled to a stage (not shown) such as a wafer stage, measurement stage, or a tube carrier stage. The magnet arrangement 514 may be, in one embodiment, arranged in quadrants, each of which is a linear magnet array, that are spaced apart along at least one axis. It should be appreciated, however, that magnet arrangement 514 may generally be any suitable magnet arrangement.

Planar motor 564 also includes a stacked coil arrangement 520 that is part of a stator. Stacked coil arrangement 520 includes at least one X coil 520a and at least one Y coil 520b that are stacked. Although at least one X coil 520a is shown as being stacked over at least one Y coil 520b, at least one Y coil 520b may instead be stacked over at least one X coil 520a.

The magnet arrays associated with stages may have a variety of different configurations. As previously mentioned, linear magnet arrays generally include either square quadrants or rectangular quadrants, although it should be appreciated that magnet arrays are not limited to including square quadrants or rectangular quadrants. Further, while magnet arrays have been described as including substantially empty spaces between at least some adjacent quadrants, some magnet arrays may not include empty spaces located between adjacent quadrants.

As will be described with respect to FIG. 6A-D, magnet arrays associated with wafer stages, measurement stages, tube carriers, or other types of planar motor driven stages may include a variety of different configurations. FIG. 6A is a diagrammatic representation of a first magnet array suitable for use in a stage or a tube carrier in accordance with an embodiment of the present invention. A magnet array 668 includes a plurality of rectangularly shaped quadrants 616a, 616b that are arranged such that there are effectively no empty spaces, e.g., no relatively significant gaps, located between adjacent quadrants 616a, 616b. In one embodiment, magnet array 668 may be approximately 240 mm by

approximately 480 mm, although it should be understood that the dimensions of magnet array 668 may vary widely.

FIG. 6B is a diagrammatic representation of a second magnet array suitable for use in a stage or a tube carrier in accordance with an embodiment of the present invention. 5 A magnet array 670 includes a plurality of rectangularly shaped quadrants 616a', 616b'. Substantially empty spaces 632' are arranged next to and between adjacent Y quadrants 616b', or quadrants 616b' that include magnets arranged to make a force in a Y direction, as well as next to and 10 between adjacent X quadrants 616a', or quadrants 616a' that include magnets arranged to make a force in an X direction. In the embodiment as shown, magnet array 670 may be approximately 360 mm by approximately 480 mm, although it 15 should be understood that the dimensions of magnet array 670 may vary widely.

FIG. 6C is a diagrammatic representation of a third magnet array suitable for use in a stage or a tube carrier in accordance with an embodiment of the present invention. 20 A magnet array 672 includes a plurality of quadrants 616a'', 616b''. A substantially empty space 632'' is arranged such that quadrants 616a'' and quadrants 616b'' are spaced apart relative to an x-axis, as shown. X quadrants 616a'', or quadrants 616a'' that include magnets arranged to make a 25 force in an X direction, and Y quadrants 616b'', or quadrants 616b'' that include magnets arranged to make a force in a Y direction, are substantially square shaped. In the embodiment as shown, magnet array 672 may be approximately 240 mm by approximately 360 mm, although it should be

understood that the dimensions of magnet array 672 may vary widely.

FIG. 6D is a diagrammatic representation of a fourth magnet array suitable for use in a stage or a tube carrier in accordance with an embodiment of the present invention. A magnet array 674 includes a plurality of rectangularly shaped quadrants 616a'", 616b'". A substantially empty space 632'" is arranged such that quadrants 616a'" and quadrants 616b'"" are spaced apart relative to an x-axis, as shown. X quadrants 616a'"" , or quadrants 616a'" that include magnets arranged to make a force in an X direction, and Y quadrants 616b'"" , or quadrants 616b'" that include magnets arranged to make a force in a Y direction, are substantially rectangularly shaped. In the embodiment as shown, magnet array 674 may be approximately 240 mm by approximately 600 mm, although it should be understood that the dimensions of magnet array 674 may vary widely.

As mentioned above, the direction in which a force is generated may vary depending upon the positioning of a coil relative to magnets in a magnet array. FIG. 10 is a diagrammatic representation of force directions associated with the positioning of an X coil over an X magnet array in accordance with an embodiment of the present invention. An X coil 720a is positioned over an X magnet array 712a. Coil 720a includes, as shown, a first side 780 and a second side 782. X magnet array 712a includes at least a first magnet 786 and a second magnet 788.

When coil 720a is positioned such that first side 780 is positioned over first magnet 786 and that second side 782

is positioned over second magnet 788. Specifically, first side 780 interacts with first magnet 786 to produce a force 784 in a positive direction relative to an x-axis, while second side 782 interacts with second magnet 788 to produce a force 790 in a positive direction relative to the x-axis.

FIG. 11 is a diagrammatic representation of force directions associated with the positioning of an X coil over a Y magnet array in accordance with an embodiment of the present invention. An X coil 820a is positioned over a Y magnet array 812b. Coil 820a includes, as shown, a first side 880 and a second side 882. Y magnet array 812b includes south magnets 886a, 886b and a north magnet 888.

When coil 820a is positioned as shown, first side 880 interacts with south magnets 886a, 886b to produce force 890 in a positive direction relative to an x-axis. First side 880 interacts with north magnet 888 such that force 884 in a negative direction relative to the x-axis is produced. When coil 820a is positioned as shown, second side 882 interacts with south magnets 886a, 886b to produce force 884 in a negative direction relative to an x-axis, and interacts with north magnet 888 such that force 890 in a positive direction relative to the x-axis is produced.

FIG. 12 is a diagrammatic cross-sectional side-view representation of flux directions and force directions associated with the positioning of an X coil over an X magnet array in accordance with an embodiment of the present invention. An X coil 920a is positioned over an X magnet array 912a. Flux lines 992 indicate the directions of magnetic flux that are generated, while arrows 984, 990

indicate force directions that are generated, when X coil 920a is positioned as shown. Forces 984, 990 are along the same direction, e.g., a positive direction along an x-axis.

FIG. 13 is a diagrammatic cross-sectional side-view representation of flux directions and force directions associated with the positioning of a Y coil over an X magnet array in accordance with an embodiment of the present invention. An Y coil 1320b is positioned over an X magnet array 1312a. Flux lines 1392 indicate the directions of magnetic flux that are generated, while arrow 1398 indicates a force direction that is generated, when Y coil 1320b is positioned as shown.

FIG. 14 is a diagrammatic representation of a moving magnet planar motor coil array and a magnet array in accordance with an embodiment. A moving magnet planar motor coil array 1420 includes a substantially "checkerboard" coil configuration. As shown, X coil groups 1420a and Y coil groups 1420b, which are each substantially square in shape, are effectively arranged in a checkerboard pattern. Each coil group 1420a, 1420b may have dimensions of approximately "N" by "N", e.g., approximately 100 millimeters by approximately 100 millimeters.

An overall magnet array 1412, which may be coupled to a stage (not shown) such as a measurement stage, includes X magnet groups 1412a and Y magnet groups 1412b. Typically, each magnet group or subarray 1412a, 1412b may have a size that is greater than or approximately equal to the size of two adjacent coil groups 1420a, 1420b. In one embodiment, each magnet group 1412a, 1412b may have dimensions of

approximately "N" by approximately "2N", e.g., approximately 100 millimeters by approximately 200 millimeters.

A stage (not shown) that is coupled to overall magnet array 1412 may have substantially the same dimensions as  
5 overall magnet array 1412 with respect to an x-axis and a y-axis, or may have larger dimensions than overall magnet array 1412 with respect to the x-axis and the y-axis. Thus, in one embodiment, a stage (not shown) may have dimensions of at least approximately "3N" by approximately "3N".

10 FIG. 15 is a diagrammatic representation of a magnet array that is of a substantially minimum size configuration that is suitable for use with a moving magnet planar motor coil array, as for example planar motor coil array 1420 of FIG. 14, in accordance with an embodiment. A magnet array  
15 1512 includes two X magnet groups 1512a, which contains X magnets, and a Y magnet group 1512b which contains Y magnets. Magnet array 1512 is configured to provide independent control of up to three vertical forces, e.g., forces along a z-axis. Magnet array 1512 may have overall dimensions of  
20 approximately "3N" by approximately "2N".

With reference to FIG. 7, a photolithography apparatus which may include planar motors having a stacked coil configuration and/or magnets arranged in quadrants having at least some substantially empty spaces there between to  
25 enable two stages to efficiently operate in relatively close proximity to each other as discussed above will be described in accordance with an embodiment. Such a planar motor may be used as a part of a wafer stage for positioning a wafer and a reticle stage for positioning a reticle (mask). In

FIG. 7, a planar motor is used for the wafer stage and a photolithography apparatus (exposure apparatus) 40 includes a wafer positioning stage 52 that may be driven by a planar motor (not shown), as well as a wafer table 51. The planar motor which drives wafer positioning stage 52 generally uses an electromagnetic force generated by magnets and corresponding armature coils arranged in two dimensions.

A wafer 64 is held in place on a wafer holder or chuck 74 which is coupled to wafer table 51. Wafer positioning stage 52 is arranged to move in multiple degrees of freedom, e.g., in up to six degrees of freedom, under the control of a control unit 60 and a system controller 62. In one embodiment, wafer positioning stage 52 may include a plurality of actuators and have a configuration as described above. The movement of wafer positioning stage 52 allows wafer 64 to be positioned at a desired position and orientation relative to a projection optical system 46.

Wafer table 51 may be levitated in a z-direction 10b by any number of voice coil motors (not shown), e.g., three voice coil motors. In one described embodiment, at least three magnetic bearings (not shown) couple and move wafer table 51 along a y-axis 10a, along an x-axis 10c, and about a z-axis 10b. In another embodiment, wafer table 51 may move as a fine stage which is arranged to move in multiple degrees of freedom, e.g., in up to six degrees of freedom to position a wafer in fine motion. The stator of the planar motor of wafer positioning stage 52 is typically supported by a base 70. Base 70 may be supported to a ground via isolators 54. Reaction forces generated by motion of wafer

stage 52 may be mechanically released to a ground surface through a frame 66. One suitable frame 66 is described in JP Hei 8-166475 and U.S. Patent No. 5,528,118, which are each herein incorporated by reference in their entireties. In preferred embodiments, base 70 acts as a counterweight absorbing the reaction force from the positioning stage 52.

An illumination system 42 is supported by a frame 72. Frame 72 is supported to the ground via isolators 54. Illumination system 42 includes an illumination source, which may provide a beam of light that may be reflected off of or transmitted through a reticle. In one embodiment, illumination system 42 may be arranged to project radiant energy, e.g., light, through a mask pattern on a reticle 68 that is supported by and scanned using a reticle stage 44 which may include a coarse stage and a fine stage or may be a single stage. The radiant energy is focused through projection optical system 46, which is supported on a projection optics frame 50 and may be supported to the ground through isolators 54. Suitable isolators 54 include those described in JP Hei 8-330224 and U.S. Patent No. 5,874,820, which are each incorporated herein by reference in their entireties.

A first interferometer 56 is supported on projection optics frame 50, and functions to detect the position of wafer table 51. Interferometer 56 outputs information on the position of wafer table 51 to system controller 62. A second interferometer 58 is supported on projection optical system 46, and detects the position of reticle stage 44 which supports a reticle 68. Interferometer 58 also outputs

position information to system controller 62. In some  
embodiments additional interferometer or other sensors, such  
as position encoders, may be used to monitor the position of  
the wafer table 51 relative to the projection optics frame  
5 50.

It should be appreciated that there are a number of  
different types of photolithographic apparatuses or devices.  
For example, photolithography apparatus 40, or an exposure  
apparatus, may be used as a scanning type photolithography  
10 system which exposes the pattern from reticle 68 onto wafer  
64 with reticle 68 and wafer 64 moving substantially  
synchronously. In a scanning type lithographic device,  
reticle 68 is moved perpendicularly with respect to an  
optical axis of a lens assembly (projection optical system  
15 46) or illumination system 42 by reticle stage 44. Wafer 64  
is moved perpendicularly to the optical axis of projection  
optical system 46 by a wafer stage 52. Scanning of reticle  
68 and wafer 64 generally occurs while reticle 68 and wafer  
64 are moving substantially synchronously.

20 Alternatively, photolithography apparatus or exposure  
apparatus 40 may be a step-and-repeat type photolithography  
system that exposes reticle 68 while reticle 68 and wafer 64  
are stationary, i.e., at a substantially constant velocity  
of approximately zero meters per second. In one step and  
25 repeat process, wafer 64 is in a substantially constant  
position relative to reticle 68 and projection optical  
system 46 during the exposure of an individual field.  
Subsequently, between consecutive exposure steps, wafer 64  
is moved by wafer positioning stage 52 perpendicularly to

the optical axis of projection optical system 46 so that the next field of semiconductor wafer 64 is brought into position relative to illumination system 42, reticle 68, and projection optical system 46 for exposure. After this  
5 exposure, these steps are repeated so that images on reticle 68 may be sequentially exposed onto the fields of wafer 64.

It should be understood that the use of photolithography apparatus or exposure apparatus 40, as described above, is not limited to being used in a  
10 photolithography system for semiconductor manufacturing. For example, photolithography apparatus 40 may be used as a part of a liquid crystal display (LCD) photolithography system that exposes an LCD device pattern onto a rectangular glass plate or a photolithography system for manufacturing a  
15 thin film magnetic head.

The illumination source of illumination system 42 may be g-line (436 nanometers (nm)), i-line (365 nm), a KrF excimer laser (248 nm), an ArF excimer laser (193 nm), and an F2-type laser (157 nm). Alternatively, illumination  
20 system 42 may also use charged particle beams such as x-ray and electron beams. For instance, in the case where an electron beam is used, thermionic emission type lanthanum hexaboride (LaB6) or tantalum (Ta) may be used as an electron gun. Furthermore, in the case where an electron  
25 beam is used, the structure may be such that either a mask is used or a pattern may be directly formed on a substrate without the use of a mask.

With respect to projection optical system 46, when far ultra-violet rays such as an excimer laser are used, glass

materials such as quartz and fluorite that transmit far  
ultra-violet rays is preferably used. When either an F2-  
type laser or an x-ray is used, projection optical system 46  
may be either catadioptric or reflective (a reticle may be  
5 of a corresponding reflective type), and when an electron  
beam is used, electron optics may comprise electron lenses  
and deflectors. As will be appreciated by those skilled in  
the art, the optical path for the electron beams is  
generally in a vacuum.

10 In addition, with an exposure device that employs  
vacuum ultra-violet (VUV) radiation of a wavelength that is  
approximately 200 nm or lower, use of a catadioptric type  
optical system may be considered. Examples of a  
catadioptric type of optical system include, but are not  
15 limited to, those described in Japan Patent Application  
Disclosure No. 8-171054 published in the Official gazette  
for Laid-Open Patent Applications and its counterpart U.S.  
Patent No. 5,668,672, as well as in Japan Patent Application  
Disclosure No. 10-20195 and its counterpart U.S. Patent No.  
20 5,835,275, which are all incorporated herein by reference in  
their entirety. In these examples, the reflecting optical  
device may be a catadioptric optical system incorporating a  
beam splitter and a concave mirror. Japan Patent  
Application Disclosure (Hei) No. 8-334695 published in the  
25 Official gazette for Laid-Open Patent Applications and its  
counterpart U.S. Patent No. 5,689,377, as well as Japan  
Patent Application Disclosure No. 10-3039 and its  
counterpart U.S. Patent No. 5,892,117, are all incorporated  
herein by reference in their entirety. These examples

describe a reflecting-refracting type of optical system that incorporates a concave mirror, but without a beam splitter, and may also be suitable for use with the present invention.

The present invention may be utilized, in one  
5 embodiment, in an immersion type exposure apparatus if suitable measures are taken to accommodate a fluid. For example, PCT patent application WO 99/49504, which is incorporated herein by reference in its entirety, describes an exposure apparatus in which a liquid is supplied to a  
10 space between a substrate (wafer) and a projection lens system during an exposure process. Aspects of PCT patent application WO 99/49504 may be used to accommodate fluid relative to the present invention.

Next, an immersion type exposure apparatus in  
15 accordance with an embodiment will be described. FIG. 16 is a schematic illustration of an immersion type exposure apparatus (hereinafter, simply referred to as an exposure apparatus) 210 in accordance with an embodiment. The exposure apparatus 210 includes a frame 212, an illumination  
20 system (irradiation apparatus) 214, a reticle stage assembly 218, an optical assembly 216, a wafer stage assembly 220, a measurement system 222, a control system 224 (not shown in FIG. 16, refer to FIG. 19), and a fluid environmental system 226 (not shown in FIG. 16, refer to FIG. 19) and the like.  
25 The exposure apparatus 210 is installed on a floor surface F.

Exposure apparatus 210 is a scanning type exposure apparatus which transfers a pattern formed on a reticle R onto a wafer W with reticle R and wafer W moving synchronously. In a scanning type exposure apparatus,

reticle R is moved perpendicularly (in an Y-axis direction) to an optical axis of optical assembly 216 by reticle stage assembly 218, and wafer W is moved perpendicularly (in the Y-axis direction) to the optical axis of optical assembly 216 by wafer stage assembly 220. Scanning of reticle R and wafer W occurs while reticle R and wafer W are moving synchronously.

Frame 212 is installed on floor surface F. Frame 212 supports the components of exposure apparatus 210, namely, illumination system 214, optical assembly 216, reticle stage assembly 218, and wafer stage assembly 220.

Illumination system 214 includes an illumination source 234 and an illumination optical assembly 236. Illumination source 234 emits a light beam. Illumination optical assembly 236 guides the light beam from illumination source 234 to reticle R. The light beam illuminates selectively different portions of reticle R.

Illumination source 234 may be a g-line source (436nm), an i-line source (365nm), a KrF excimer laser (248nm), an ArF excimer laser (193nm) or a F2 laser (157 nm). Alternatively, illumination source 234 may generate a charged particle beam or an X-ray beam.

Reticle stage assembly 218 includes a reticle stage 238 that retains reticle R and a reticle stage mover assembly 240 that drives reticle stage 238. The reticle stage mover assembly 240 moves reticle stage 238 in at least directions of three degrees of freedom, which are an X-axis direction, a Y-axis direction, and a rotation direction

around a Z-axis ( $\theta_z$  direction) using, for example, a driver such as a linear motor and the like.

Optical assembly 216 irradiates the light beam passing through reticle R on wafer W, and projects a reduced image  
5 of the pattern formed on reticle R on wafer W. Optical assembly 16 need not be limited to a reduction system, and could also be an equal or greater magnification system.

Wafer stage assembly 220 includes a base member 232 mounted on floor surface F, a wafer stage 264 which moves  
10 while retaining wafer W on base member 232, a measuring instrument such as an aerial image measuring instrument and the like, a measurement stage 266 on which measurement members such as reference marks and the like are provided, and a stage mover assembly 244 which drives wafer stage 264  
15 and measurement stage 266.

Here, a configuration of each part of wafer stage 264, especially of stage mover assembly 244 which moves wafer stage 264 will be described in detail. FIG. 17 shows wafer stage assembly 220, especially, a planar view of an  
20 arrangement of armature coils 238X (238Y) within base member 232 and magnet units 255X<sub>1</sub>, 255X<sub>2</sub>, 255Y<sub>1</sub>, and 255Y<sub>2</sub> within wafer stage 264. FIG. 18A shows a cross section view along line A-A in FIG. 17.

Wafer stage 264 includes a mover 251, a Z drive  
25 mechanism (not shown) and the like. Mover 251 is fixed to the bottom portion of wafer stage 264, and mover 251 and a stator 260 housed in the upper portion of base member 232 which will be described later structure a planar motor (wafer stage mover assembly) 244W. On wafer stage 264,

wafer W is fixed, for example, by vacuum chucking. Incidentally, wafer stage mover assembly 244W and a measurement stage mover assembly 244M which will be described later will be referred to collectively as stage mover assembly 244.

Mover 251, as illustrated in FIG. 17, has a magnet unit 255X<sub>1</sub> in a first quadrant (i.e., a portion which is half of the +X side and half of the +Y side) and a magnet unit 255X<sub>2</sub> in a third quadrant (i.e., a portion which is half of the -X side and half of the -Y side), respectively. Further, mover 251 has a magnet unit 255Y<sub>1</sub> in a second quadrant (i.e., a portion which is half of the -X side and half of the +Y side) and a magnet unit 255Y<sub>2</sub> in a fourth quadrant (a portion which is half of the +X side and half of the -Y side), respectively. Here, space of a predetermined width is provided between magnet unit 255X<sub>1</sub> and magnet unit 255Y<sub>1</sub>, and magnet unit 255X<sub>2</sub> and magnet unit 255Y<sub>2</sub>, respectively. That is, magnet units 255X<sub>1</sub> and 255X<sub>2</sub> are arranged spaced in the X-axis direction, with the space equal to or more than each width (the dimension in the X-axis direction) of a plurality of armature coils 238X, and similarly, magnet units 255Y<sub>1</sub> and 255Y<sub>2</sub> are arranged spaced in the X-axis direction, with the space equal to or more than each length (the dimension in the X-axis direction) of a plurality of armature coils 238Y. Magnet units 255X<sub>1</sub> and 255X<sub>2</sub> are structured from a plurality of rectangular solid shaped magnets that are arranged so that adjacent magnetic pole surfaces in the X-axis direction have polarity different from each other and whose longitudinal direction

is in the Y-axis direction. Magnet units 255Y<sub>1</sub> and 255Y<sub>2</sub> are structured from a plurality of rectangular solid shaped magnets that are arranged so that the adjacent magnetic pole surfaces in the Y-axis direction have polarity different  
5 from each other and whose longitudinal direction is in the X-axis direction. Further, mover 251 has an air slider (not shown), and wafer stage 264 is supported by levitation (refer to FIG. 18A) on the upper surface of base member 232, via a clearance, for example, of around 5 $\mu$ m.

10 While, in the present embodiment, the case has been described as an example where planar motor (wafer stage mover assembly) 244W is of a 3DOF type that generates a thrust in the X, Y and  $\theta_z$  directions, the configuration of the planar motor (wafer stage mover assembly) is not  
15 limited to this type. For example, the planar motor (wafer stage mover assembly) may be a planar motor of a 6DOF type that generates a thrust also in the Z,  $\theta_x$  and  $\theta_y$  directions in addition to the X, Y and  $\theta_z$  directions. In the case of the planar motor of the 6DOF type, the thrust of the Z  
20 direction component may be configured of a combination of X component and Z component generated by using the X coils, and Y component and Z component generated by using the Y coils. Further, in the case of using the planar motor of the 6DOF type, a mover (the wafer stage) may be magnetically  
25 levitated above the base member by the thrust in the Z direction generated by the planar motor, and therefore, no air sliders are needed.

As illustrated in FIG. 18A, on the upper surface of base member 232 which faces mover 251, a movement plane of

mover 251 is formed. Further, as it may be seen from FIGS. 17 and 18A, in an inner space of base member 232, armature coils 238X are arranged along the movement plane in the X-axis direction in a plurality of rows on the upper layer side. These armature coils 238X structure an X coil unit 260X. As armature coil 238X, a rectangular coil whose length of the longer side is three times the length of the shorter side is used. Further, armature coils 238Y are arranged along the movement plane in the Y-axis direction in a plurality of rows on the lower layer side within inner space 41. These armature coils 238Y structure a Y coil unit 260Y. (Armature coils 238Y and Y coil unit 260Y are not shown in FIG. 17. Refer to FIG. 21 and the like.) As armature coil 238Y, similar to armature coil 238X, a rectangular coil whose length of the longer side is three times the length of the shorter side is used. A stacking type stator 260 is structured by X coil unit 260X and Y coil unit 260Y that are vertically stacked. Incidentally, as previously described, examples of various modified arrangements may be employed for stacking type stator 260.

In the arrangement described above, as described earlier using FIG. 10, X coil unit 260X provides a driving force in the X-axis direction (non-scanning direction) to magnet units 255X<sub>1</sub> and 255X<sub>2</sub>, by exciting (generating a flow of an excitation current) the plurality of armature coils 238X configuring X coil unit 260X. Similarly, Y coil unit 260Y provides a driving force in the Y-axis direction (non-scanning direction) to magnet units 255Y<sub>1</sub> and 255Y<sub>2</sub>, by exciting (generating a flow of an excitation current) the

plurality of armature coils 238Y configuring Y coil unit 260Y. This drives wafer stage 264 in a two-dimensional direction (XY directions) on base member 232.

Incidentally, as described earlier using FIG. 11, the driving force in the X-axis direction to magnet units 255Y<sub>1</sub> and 255Y<sub>2</sub> is not generated, even if the plurality of armature coils 238X are excited. Similarly, the driving force in the Y-axis direction to magnet units 255X<sub>1</sub> and 255X<sub>2</sub> is not generated, even if the plurality of armature coils 238Y are excited.

Next, each part structuring measurement stage 266, especially stage mover assembly 244 which drives measurement stage 266 will be described in detail. FIG. 17 shows wafer stage assembly 220, especially, a planar view of an arrangement of magnet units 285X<sub>1</sub>, 285X<sub>2</sub>, 285Y<sub>1</sub>, and 285Y<sub>2</sub> within measurement stage 266. FIG. 18B shows a cross section view along line B-B in FIG. 17.

Measurement stage 266 includes a mover 281, the Z drive mechanism (not shown) and the like. Mover 281 is fixed to the bottom portion of measurement stage 266, and mover 281 and stator 260 structure planar motor (measurement stage mover assembly) 244M. Measurement stage mover assembly 244M and wafer stage mover assembly 244W previously described are referred to collectively as stage mover assembly 244.

Various measurement members are provided in measurement stage 266 (refer to, for example, U.S. Patent Application Publication No. 2011/0025998). As the measurement members, for example, an illuminance

irregularity sensor, an aerial image measuring instrument, a wavefront aberration measuring instrument, an illuminance monitor (none of which are shown) and the like are provided.

Mover 281, as illustrated in FIG. 17, has a magnet unit 285X<sub>1</sub> in a first quadrant (i.e., a portion which is half of the +X side and half of the +Y side) and a magnet unit 285X<sub>2</sub> in a third quadrant (i.e., a portion which is half of the -X side and half of the -Y side), respectively. Further, mover 281 has a magnet unit 285Y<sub>1</sub> in a second quadrant (i.e., a portion which is half of the -X side and half of the +Y side) and a magnet unit 285Y<sub>2</sub> in a fourth quadrant (a portion which is half of the +X side and half of the -Y side), respectively. Here, space of a predetermined width is provided between magnet unit 285X<sub>1</sub> and magnet unit 285Y<sub>1</sub>, and magnet unit 285X<sub>2</sub> and magnet unit 285Y<sub>2</sub>, respectively. That is, magnet units 285X<sub>1</sub> and 285X<sub>2</sub> are arranged spaced in the X-axis direction, with the space equal to or more than each width (the dimension in the X-axis direction) of the plurality of armature coils 238X, and similarly, magnet units 285Y<sub>1</sub> and 285Y<sub>2</sub> are arranged spaced in the X-axis direction, with the space equal to or more than each length (the dimension in the X-axis direction) of the plurality of armature coils 238Y. Magnet units 285X<sub>1</sub> and 285X<sub>2</sub> are structured from a plurality of rectangular solid shaped magnets that are arranged so that adjacent magnetic pole surfaces in the X-axis direction have polarity different from each other and whose longitudinal direction is in the Y-axis direction. Magnet units 285Y<sub>1</sub> and 285Y<sub>2</sub> are structured from a plurality of rectangular solid shaped

magnets that are arranged so that adjacent magnetic pole surfaces in the Y-axis direction have polarity different from each other and whose longitudinal direction is in the X-axis direction. Further, mover 281 has an air slider (not shown), and measurement stage 266 is supported by levitation (refer to FIG. 18B) on the upper surface of base member 232, via a clearance, for example, of around 5 $\mu$ m.

While, in the present embodiment, the case has been described as an example where planar motor (measurement stage mover assembly) 244M is of a 3DOF type that generates a thrust in the X, Y and  $\theta_z$  directions, the configuration of planar motor (measurement stage mover assembly) 244M is not limited to this type, and similarly to the forgoing planar motor (wafer stage mover assembly), a planar motor of a 6DOF type may be used, for example.

In the arrangement described above, as described earlier using FIG. 10, X coil unit 260X provides a driving force in the X-axis direction to magnet units 285X<sub>1</sub> and 285X<sub>2</sub>, by exciting (generating a flow of an excitation current) the plurality of armature coils 238X configuring X coil unit 260X. Similarly, Y coil unit 260Y provides a driving force in the Y-axis direction to magnet units 285Y<sub>1</sub> and 285Y<sub>2</sub>, by exciting (generating a flow of an excitation current) the plurality of armature coils 238Y configuring Y coil unit 260Y. This drives measurement stage 266 in a two-dimensional direction (XY directions) on base member 232.

Incidentally, as described earlier using FIG. 11, the driving force in the X-axis direction to magnet units 285Y<sub>1</sub> and 285Y<sub>2</sub> is not generated, even if the plurality of

armature coils 238X are excited. Similarly, the driving force in the Y-axis direction to magnet units 285X<sub>1</sub> and 285X<sub>2</sub> is not generated, even if the plurality of armature coils 238Y are excited.

5 Measurement system 222 monitors movement of reticle stage 238 (reticle R) and wafer stage 264 (wafer W) to optical assembly 216 (or some other reference). In measurement system 222, for example, laser interferometers, encoders, and the like may be used.

10 Environmental system 226 controls the environment in a gap between optical assembly 216 and wafer W. The gap includes a projection field in which an image of a pattern is projected. Environmental system 226 delivers and/or injects immersion fluid into the gap using spray nozzles,  
15 electro-kinetic sponges, porous materials, etc. and removes the immersion fluid from the gap using vacuum pumps, sponges, and the like, which allows an immersion area L<sub>q</sub> filled with the immersion liquid to be formed within the gap (refer, for example, to FIG. 20).

20 FIG. 19 shows a block diagram illustrating an input/output relation of control system 224 which mainly structures the control system of exposure apparatus 210, and has overall control over each part structuring the exposure apparatus. Control system 224 includes a workstation (or a  
25 microcomputer) and the like.

Control system 224 receives measurement information from measurement system 222, and drives reticle R controlling reticle stage assembly 218 and drives wafer W controlling wafer stage assembly 220 to precisely drive

reticle R and wafer W simultaneously. Further, control system 224 may control the operation of environmental system 226.

5 Next, a scrub operation of wafer stage 264 and measurement stage 266 to move on to wafer exchange and various measurements using measurement stage 266 after scanning exposure of wafer W has been completed will be described.

10 FIG. 20A shows wafer stage 264 and measurement stage 266 when scanning exposure of wafer W has been completed. At this point, wafer W (wafer stage 264) is positioned directly below optical assembly 216. That is, immersion area Iq is positioned on wafer W (wafer stage 264). Measurement stage 266 is positioned near wafer stage 264.

15 When the scanning exposure has been completed, control system 224 drives measurement stage 266 in a direction (-Y direction) indicated by an outlined arrow as illustrated in FIG. 20B, and moves the -Y edge portion of measurement stage 266 close to the +Y edge portion of wafer stage 264 via a  
20 slight gap (e.g., 0.1 to 1.0mm). This structures a surface with the surface of wafer stage 264 and the surface of measurement stage 266 that is flush with the surface of wafer W and appears to be completely flat.

25 After wafer stage 264 and measurement stage 266 are in close proximity, control system 224 drives wafer stage 264 and measurement stage 266 in the -Y direction while maintaining the state in close proximity, as illustrated in FIG. 20C. FIG. 20C shows a state where wafer stage 264 is driven in a direction (-Y direction) indicated by a black

arrow, and measurement stage 266 is driven in a direction (-  
Y direction) indicated by an outlined arrow. By this  
operation, wafer stage 264 withdraws from right below  
optical assembly 216, and instead measurement stage 266 is  
5 arranged directly below optical assembly 216. Because both  
of the stages 264 and 266 are in close proximity via a  
slight gap at this point, the immersion liquid which forms  
immersion area Lq does not leak from both stages, and  
immersion area Lq moves from above wafer stage 264 to above  
10 measurement stage 266.

Here, when wafer stage 264 and measurement stage 266  
are in close proximity and both stages are driven while  
maintaining the close proximity state, in the embodiment,  
both stages are made to be in close proximity so that a  
15 driving force is generated only between each of the  
plurality of armature coils 238Y within stator 260 and  
either one of magnet units 255Y<sub>1</sub> and 255Y<sub>2</sub> within wafer  
stage 264 (mover 251) or magnet units 285Y<sub>1</sub> and 285Y<sub>2</sub> within  
measurement stage 266 (mover 281), and a driving force is  
20 generated only between each of the plurality of armature  
coils 238X within stator 260 and either one of magnet units  
255X<sub>1</sub> and 255X<sub>2</sub> within wafer stage 26 or magnet units 285X<sub>1</sub>  
and 285X<sub>2</sub> within measurement stage 266. That is, both  
stages are made to be in close proximity in a state where  
25 magnet units 255Y<sub>1</sub> and 255Y<sub>2</sub> within wafer stage 264 are to  
be provided apart from magnet units 285Y<sub>1</sub> and 285Y<sub>2</sub> within  
measurement stage 266 in either the X-axis direction or the  
Y-axis direction by a distance equal to or more than each  
width of the plurality of armature coils 238Y, and magnet

units 255X<sub>1</sub> and 255X<sub>2</sub> within wafer stage 264 are to be provided apart from magnet units 285X<sub>1</sub> and 285X<sub>2</sub> within measurement stage 266 in either the X-axis direction or the Y-axis direction by a distance equal to or more than each  
5 width of the plurality of armature coils 238X.

To be more specific, according to the symmetrical arrangement of the magnet units of wafer stage 264 and measurement stage 266, as illustrated in FIG. 21, the center in the X-axis direction is made to coincide for both stages  
10 and the +Y edge portion of wafer stage 264 is made to be in close proximity with the -Y edge portion of measurement stage 266. This makes magnet unit 255X<sub>1</sub> within wafer stage 264 proximate with magnet unit 285Y<sub>2</sub> within measurement stage 266, and magnet unit 255Y<sub>1</sub> within wafer stage 264  
15 proximate with magnet unit 285X<sub>2</sub> within measurement stage 266. At this point, magnet units 255Y<sub>1</sub> and 255Y<sub>2</sub> within wafer stage 264 face armature coil 238Y within areas 260Y<sub>11</sub> and 260Y<sub>21</sub>, respectively, and magnet units 285Y<sub>1</sub> and 285Y<sub>2</sub> within measurement stage 266 face armature coil 238Y within  
20 areas 260Y<sub>12</sub> and 260Y<sub>22</sub>, respectively. Here, areas 260Y<sub>11</sub>, 260Y<sub>21</sub>, 260Y<sub>12</sub>, and 260Y<sub>22</sub> do not overlap one another. That is, magnet units 255Y<sub>1</sub> and 255Y<sub>2</sub>, and 285Y<sub>1</sub> and 285Y<sub>2</sub> each always face a different armature coil 238Y. Accordingly,  
25 from each of the plurality of armature coils 238Y, a driving force is generated only between either magnet units 255Y<sub>1</sub> and 255Y<sub>2</sub> within wafer stage 264 or magnet units 285Y<sub>1</sub> and 285Y<sub>2</sub> within measurement stage 266.

Incidentally, while in the description above the +Y edge portion of wafer stage 264 and the -Y edge portion of

measurement stage 266 are made to be in close proximity by making the centers in the X-axis direction of both the stages coincide with each other, this is not intended to be limiting. More specifically, the +Y edge portion of wafer stage 264 and the -Y edge portion of measurement stage 266 may be made to be in close proximity by making the centers in the X-axis direction of both the stages shifted in the X-axis direction in a range that satisfies the above-described conditions, for example, a range where magnet unit 285Y<sub>2</sub> and magnet unit 255Y<sub>1</sub> do not face each other.

Similarly, as illustrated in FIG. 22, magnet units 255X<sub>1</sub> and 255X<sub>2</sub> within wafer stage 264 face armature coil 238X within areas 260X<sub>11</sub> and 260X<sub>21</sub>, respectively, and magnet units 285X<sub>1</sub> and 285X<sub>2</sub> within measurement stage 266 face armature coil 238X within areas 260X<sub>12</sub> and 260X<sub>22</sub>, respectively. Here, areas 260X<sub>11</sub>, 260X<sub>21</sub>, 260X<sub>12</sub>, and 260X<sub>22</sub> do not overlap one another. That is, magnet units 255X<sub>1</sub> and 255X<sub>2</sub>, and 285X<sub>1</sub> and 285X<sub>2</sub> each always face a different armature coil 238X. Accordingly, from each of the plurality of armature coils 238X, a driving force is generated only between either magnet units 255X<sub>1</sub> and 255X<sub>2</sub> within wafer stage 264 or magnet units 285X<sub>1</sub> and 285X<sub>2</sub> within measurement stage 266.

Incidentally, as previously described, the driving force is not generated in each magnet unit even if magnet units 255Y<sub>1</sub> and 255Y<sub>2</sub>, and 285Y<sub>1</sub> and 285Y<sub>2</sub> face armature coil 238X, and the driving force is not generated in each magnet unit even if magnet unit 255X<sub>1</sub> and 255X<sub>2</sub>, and 285X<sub>1</sub> and 285X<sub>2</sub> face armature coil 238Y.

Accordingly, as described earlier using FIGS. 3A to 3C, even in the case when wafer stage 264 is in close proximity with measurement stage 266 as in the scrub operation described above, by exciting each of the plurality of  
5 armature coils 238X and 238Y within stator 260, drive control of both stages may be performed independently.

After immersion area Lq has been moved, control system 224 drives only wafer stage 264 in a direction (-Y direction) indicated by a black arrow while measurement  
10 stage 266 is still positioned directly below optical assembly 216, as illustrated in FIG. 20D. Wafer stage 264 is moved to a wafer exchange area (not shown), and wafer W which has been exposed is exchanged to a new wafer. Concurrently with this operation, various measurements such  
15 as the aerial image measurement and the like is performed using measurement stage 266 positioned directly below optical assembly 216, in a state where immersion area Lq is maintained above measurement stage 266.

After the wafer exchange and the various measurements  
20 have been completed, control system 224 performs a reversed operation of the scrub operation described above, and withdraws measurement stage 266 from directly below optical assembly 216, and positions wafer stage 264 directly under optical assembly 216 instead. By this operation, immersion  
25 area Lq is moved from above measurement stage 266 to above wafer stage 264 (the new wafer). After immersion area Lq has been moved, wafer alignment and scanning exposure are performed on the new wafer.

Incidentally, in the embodiment described above, while the arrangement where the same type of magnet units are provided spaced apart in the X-axis direction was employed for magnet units 255X<sub>1</sub> and 255X<sub>2</sub>, and 255Y<sub>1</sub> and 255Y<sub>2</sub> within wafer stage 264 (mover 251), an arrangement where the same type of magnet units are provided spaced apart in the Y-axis direction may also be employed. In general, any suitable arrangement may be employed such as the arrangement illustrated in FIG. 3A, FIG. 4, FIG. 6A to FIG. 6D, FIG. 14, FIG. 15 or the like, as long as the same type of magnet units are arranged spaced apart by a distance equal to or more than the width of the corresponding armature coils 238X and 238Y. In such a case, because the same type of magnets facing a single armature coil 238X or 238Y is two or less, drive control of both stages may be performed independently.

Further, while the arrangement of placing two each of the same type of magnet units 255X<sub>1</sub> and 255X<sub>2</sub>, and 255Y<sub>1</sub> and 255Y<sub>2</sub> in wafer stage 264 was employed, an arrangement of placing one X magnet unit and one Y magnet unit may also be employed. Similarly, while the arrangement of placing two each of the same type of magnet units 285X<sub>1</sub> and 285X<sub>2</sub>, and 285Y<sub>1</sub> and 285Y<sub>2</sub> in measurement stage 266 was employed, an arrangement of placing one X magnet unit and one Y magnet unit may also be employed. Even in such a case, wafer stage 264 and measurement stage 266 may be driven in the XY two-dimensional direction.

Further, instead of stacking type stator 260 described above in the embodiment, in the inner space of base member 232, stator (planar motor coil array) 1420 may be used whose

X coil unit (X coil group) 1420b and Y coil unit (Y coil group) 1420a are alternately arranged in the X-axis direction and the Y-axis direction as illustrated in FIG. 14. However, X coil unit 1420b (Y coil unit 1420a) is structured  
5 as one rectangular shaped coil unit having four sides whose length is equal to one another, with three coils that are armature coils 238X (238Y) whose longitudinal direction is in the Y-axis direction (X-axis direction) and is arranged in the X-axis direction (Y-axis direction).

10 Further, in the embodiment described above, the case has been described where in the scrub operation of wafer stage 264 and measurement stage 266, that is, in the case when wafer stage 264 and measurement stage 266 are in close proximity in the Y-axis direction and both stages are driven  
15 in the direction in close proximity while maintaining the proximity state, drive control of both stages may be performed independently. However, also in the case when both stages are driven in a direction intersecting the direction in close proximity while maintaining the proximity  
20 state, i.e., in the X-axis direction, or in the case when both stages are in close proximity in the X-axis direction, and both stages are driven in the direction in close proximity or in the direction intersecting the direction in close proximity, magnet units 255Y<sub>1</sub> and 255Y<sub>2</sub>, and 285Y<sub>1</sub> and  
25 285Y<sub>2</sub> each face a different armature coil 238Y, and magnet units 255X<sub>1</sub> and 255X<sub>2</sub>, and 285X<sub>1</sub> and 285X<sub>2</sub> each face a different armature coil 238X, which allows drive control of both stages to be performed independently.

FIG. 8 is a process flow diagram which illustrates the steps associated with fabricating a semiconductor device in accordance with an embodiment of the present invention. A process of fabricating a semiconductor device begins at step 5 1101 in which the function and performance characteristics of a semiconductor device are designed or otherwise determined. Next, in step 1102, a reticle or mask in which has a pattern is designed based upon the design of the semiconductor device. It should be appreciated that in a 10 substantially parallel step 1103, a wafer is typically made from a silicon material. In step 1104, the mask pattern designed in step 1102 is exposed onto the wafer fabricated in step 1103 through the use of a lithography system. One process of exposing a mask pattern onto a wafer will be 15 described below with respect to FIG. 9. In step 1105, the semiconductor device is assembled. The assembly of the semiconductor device generally includes, but is not limited to including, wafer dicing processes, bonding processes, and packaging processes. Finally, the completed device is 20 inspected in step 1106. Upon successful completion of the inspection in step 1106, the completed device may be considered to be ready for delivery.

FIG. 9 is a process flow diagram which illustrates the steps associated with wafer processing in the case of 25 fabricating semiconductor devices in accordance with an embodiment of the present invention. In step 1211, the surface of a wafer is oxidized. In step 1212 which is a chemical vapor deposition (CVD) step in one embodiment, an insulation film may be formed on the wafer surface. In step

1213, electrodes are formed on the wafer by vapor deposition. Ions may be implanted in the wafer using substantially any suitable method in step 1214. As will be appreciated by those skilled in the art, steps 1211-1214 are generally  
5 considered to be preprocessing steps for wafers during wafer processing. These preprocessing steps may be sequential or performed individually. Further, it should be understood that selections made in each step, e.g., the concentration of various chemicals to use in forming an insulation film in  
10 step 1212, may be made based upon processing requirements.

At each stage of wafer processing, when preprocessing steps have been completed, post-processing steps may be implemented. During post-processing, initially, in step 1215, photoresist is applied to a wafer. Then, in step 1216,  
15 an exposure device may be used to transfer the circuit pattern of a reticle to a wafer.

After the circuit pattern on a reticle is transferred to a wafer, the exposed wafer is developed in step 1217. Once the exposed wafer is developed, parts other than  
20 residual photoresist, e.g., the exposed material surface, may be removed by etching in step 1218. Finally, in step 1219, any unnecessary photoresist that remains after etching may be removed. As will be appreciated by those skilled in the art, multiple circuit patterns may be formed through the  
25 repetition of the preprocessing and post-processing steps.

Although only a few embodiments of the present invention have been described, it should be understood that the present invention may be embodied in many other specific forms without departing from the spirit or the scope of the

present invention. By way of example, a magnet array has been described as being substantially coupled to a stage and separated from a stator comprising a coil array. The stator, which may include a stacked coil arrangement, is generally  
5 coupled to a ground or a counter mass. In lieu of a magnet array being coupled to a stage while a coil array is coupled to a ground or a counter mass, the magnet array may be coupled to a ground or a counter mass while a coil array is coupled to a stage.

10 While the use of a motor described above has generally been described as being suitable for use in a lithography system such as an immersion lithography system, the motor described above is not limited to being used in an immersion lithography system. In other words, a planar motor that  
15 utilizes a magnet array in which quadrants are spaced apart in at least one direction and/or a stator that includes a stacked coil arrangement may be used in any suitable system.

Alternating of coils pairings of a stacked coil arrangement have been described as including coil pairings  
20 in which an X coil is positioned on top of a Y coil are alternated with coil pairings in which a Y coil is positioned on top of an X coil. It should be appreciated that in lieu of alternating coil pairings, a stacked coil arrangement may be configured such that the stacked coil  
25 arrangement effectively includes one or more first areas in which X coils are positioned on top of Y coils and one or more second areas in which Y coils are positioned on top of X coils.

It should be appreciated that it may be beneficial to include a space between quadrants of magnets, e.g., space "w" shown in Fig 3A, even in a system that includes substantially only one stage. Such a space "w" utilized in a system that includes substantially only one stage may ensure that there is no coil that overlaps the two X or the two Y quadrants on a single stage, thereby facilitating the accurate control of stage motion.

### Claims

1. A stage apparatus comprising:
  - a first stage;
  - a first magnet array, the first magnet array being
  - 5 associated with the first stage; and
  - a stator arrangement, the stator arrangement being arranged to cooperate with the first magnet array to drive the first stage, wherein the stator arrangement includes a plurality of coils, the plurality of coils including a first
  - 10 coil of a first type, a second coil of a second type, a third coil of the first type, and a fourth coil of the second type, the first coil and the fourth coil being in a first plane, the second coil and the third coil being in a second plane, wherein the first coil is stacked over the
  - 15 second coil and the fourth coil is stacked over the third coil.
  
2. The stage apparatus of claim 1 wherein the first coil and the third coil are arranged to provide a force in a
- 20 first direction along a first axis, and the second coil and the fourth coil are arranged to provide a force in a second direction along a second axis, and wherein the first coil is stacked over the second coil relative to a third axis.
  
- 25 3. The stage apparatus of claim 2 wherein the first magnet array includes at least a first quadrant and a second quadrant, the first quadrant and the second quadrant having an empty space there between such that the first quadrant is

spaced apart from the second quadrant by a distance along the first axis.

4. The stage apparatus of claim 3 wherein the first  
5 coil has a first coil length, and the distance is greater than or approximately equal to the first coil length.

5. The stage apparatus of claim 3 wherein the first  
quadrant includes a first magnet and the second quadrant  
10 includes a second magnet, the first magnet being arranged to cooperate with the stator arrangement to generate the force in the first direction, the second magnet being arranged to cooperate with the stator arrangement to generate the force in the second direction.

15

6. The stage apparatus of claim 3 wherein the first  
quadrant includes a first magnet and the second quadrant  
includes a second magnet, wherein both the first and second  
magnets are arranged to cooperate with the stator  
20 arrangement to generate the force in the first direction.

7. The stage apparatus of claim 5 wherein the first  
quadrant is further arranged to cooperate with the stator  
arrangement to generate a first force along the third axis.

25

8. The stage apparatus of claim 7 wherein the second  
quadrant is further arranged to cooperate with the stator  
arrangement to generate a second force along the third axis.

9. The stage apparatus of claim 1 further including:  
a second stage; and  
a second magnet array, the second magnet array  
being associated with the second stage, wherein the second  
5 magnet array is arranged to cooperate with the stator  
arrangement to drive the second stage.

10. The stage apparatus of claim 9 wherein a first  
portion of the first magnet array is periodically positioned  
10 near a second portion of the second magnet array, the first  
portion of the first magnet array being arranged to  
cooperate with the stator arrangement to generate a first  
force on the first stage along a first axis, the second  
portion of the second magnet array being arranged to  
15 cooperate with the stator arrangement to generate a second  
force on the first stage along a second axis.

11. An exposure apparatus comprising the stage  
apparatus of claim 1.

20

12. A wafer formed using the exposure apparatus of  
claim 11.

13. A stage apparatus comprising:  
25 a first stage;  
a first magnet arrangement, the first magnet  
arrangement being associated with the first stage, the first  
magnet arrangement including a first quadrant and a second  
quadrant, the first quadrant having at least a first magnet

arranged parallel to a first axis, the second quadrant having at least a second magnet arranged parallel to a second axis, wherein the first quadrant is adjacent to the second quadrant relative to the first axis, the first  
5 quadrant further being spaced apart from the second quadrant by a distance relative to the second axis, the distance being greater than or approximately equal to the first coil length; and

a stator arrangement, the stator arrangement  
10 including a first coil, the first coil having a first coil length, wherein the stator arrangement is configured to cooperate with the first magnet arrangement to drive the first stage.

15 14. The stage apparatus of claim 13 wherein the first quadrant includes a linear magnet array, wherein the first quadrant is arranged to cooperate with the stator arrangement to generate a first force along the second axis and wherein the second quadrant is arranged to cooperate  
20 with the stator arrangement to generate a second force along the first axis.

15 15. The stage apparatus of claim 14 wherein the first quadrant is further arranged to cooperate with the stator  
25 arrangement to generate a third force along a third axis.

16. The stator arrangement of claim 13 wherein the stator arrangement further includes a second coil and the

first coil is stacked over the second coil relative to a third axis.

17. An exposure apparatus comprising the stage  
5 apparatus of claim 13.

18. A wafer formed using the exposure apparatus of claim 17.

10 19. A stage apparatus comprising:  
a first stage;  
a second stage;  
a first magnet array, the first magnet array being associated with the first stage, the first magnet array  
15 including a first quadrant having at least a first magnet and a second quadrant having at least a second magnet, the first quadrant being arranged to produce a force in a first direction, the second quadrant being arranged to produce a force in a second direction;  
20 a second magnet array, the second magnet array being associated with the second stage, the second magnet array including a third quadrant having at least a third magnet and a fourth quadrant having at least a fourth magnet, the third quadrant being arranged to produce a force in the  
25 first direction, the fourth quadrant being arranged to produce a force in the second direction; and  
a stator arrangement, the stator arrangement including at least one coil, the stator arrangement being arranged to cooperate with the first magnet array to drive

the first stage, the stator arrangement further being arranged to cooperate with the second magnet array to drive the second stage, wherein when the fourth quadrant is approximately adjacent to the first quadrant, the second  
5 stage moves in closer proximity to the first stage than when the third quadrant is approximately adjacent to the first quadrant.

20. The stage apparatus of claim 19 wherein the first  
10 stage is a wafer stage arranged to carry a wafer the second stage is one selected from a group including a measurement stage and a tube carrier stage.

21. The stage apparatus of claim 19 wherein the first  
15 stage is a first wafer stage and the second stage is a second wafer stage.

22. The stage apparatus of claim 19 wherein the first  
quadrant is adjacent to the second quadrant and spaced apart  
20 from the second quadrant by a first distance relative to a first axis, and wherein the third quadrant is adjacent to the fourth quadrant and separated by a second distance relative to the first axis.

25 23. The stage apparatus of claim 22 wherein the at least one coil has a coil length, and wherein the first distance is greater than or approximately equal to the coil length and the second distance is greater than or approximately equal to the coil length.

24. The stage apparatus of claim 19 wherein the at least one coil includes a first coil and a second coil, the first coil being stacked on top of the second coil.

5

25. An exposure apparatus comprising the stage apparatus of claim 19.

26. A wafer formed using the exposure apparatus of claim 25.

10

27. A stage apparatus comprising:

a first stage;

15

a stator arrangement, the stator arrangement including at least a first coil group including a first X coil and a second coil group including a first Y coil, wherein the first X coil has a size of a unit and the first Y coil has the size of the unit; and

20

a first magnet array, the first magnet array being associated with the first stage and arranged to cooperate with the stator arrangement to drive the first stage, the first magnet array including a first subarray having at least a X first magnet, a second subarray having at least a first Y magnet, and a third subarray having at least a second X magnet, wherein the first subarray has a size of at least approximately two units, the second subarray has the size of at least approximately two units, and the third subarray has the size of at least approximately two units, and wherein the first subarray provides independent control

25

of a first vertical force, the second subarray provides independent control of a second vertical force, and the third subarray provides independent control of a third vertical force.

5

28. An exposure apparatus irradiating an energy beam and forming a pattern on an object, the apparatus comprising:

10 a first and second movable bodies, the first and second movable bodies moving along a plane provided on a base member; and

15 a driving device, the driving device driving a first movable body using a stator including a plurality of coils arranged within the plane and a first mover including at least one first magnet and at least one second magnet provided within the first movable body facing the plurality of coils, and driving a second movable body using the stator and a second mover including at least one third magnet and at least one fourth magnet provided within the second  
20 movable body facing the plurality of coils, wherein the first movable body and the second movable body become proximate to generate a driving force between each of the plurality of coils and only one of the first and third magnets, and a driving force between each of the plurality  
25 of coils and only one of the second and fourth magnets.

29. The exposure apparatus of claim 28, the apparatus further comprising:

an optical system irradiating the energy beam on the object; and

a liquid supply device, the liquid supply device supplying liquid to a space between the optical system and the object, wherein the liquid is moved between the first and second movable bodies by driving the first and second movable bodies in a direction in close proximity of the first and second movable bodies while maintaining a close proximity state of the first movable body holding the object and the second movable body.

30. The exposure apparatus of claim 28 wherein the first and the third magnets each face a different coil of the plurality of coils and the second and fourth magnets each face a different coil of the plurality of coils when the first and second movable bodies are in close proximity.

31. The exposure apparatus of claim 28 wherein the driving device drives the first movable body in a first direction with the first magnet and in a second direction intersecting the first direction with the second magnet, and the second movable body in the first direction with the third magnet and in the second direction with the fourth magnet.

32. The exposure apparatus of claim 31 wherein a space is provided, the space being one of a dimension equal to each of the plurality of coils and larger in a direction in one of the first and second directions between the first

magnet and the third magnet, as well as a dimension equal to each of the plurality of coils and larger in the direction in one of the first and second directions between the second magnet and the fourth magnet when the first and second  
5 movable bodies are in close proximity.

33. The exposure apparatus of claim 31 wherein a plurality of at least one of the first and second magnets are placed arranged spaced apart in a dimension equal to  
10 each of the plurality of coils and larger in one of the first and second directions, within the first movable body.

34. The exposure apparatus of claim 31 wherein a plurality of the first and second magnets are provided in an  
15 arrangement where the first and second magnets are adjacent to each other in each of the first and second directions within the first movable body.

35. The exposure apparatus of claim 33 wherein as for  
20 a direction in which the first and second movable bodies are in close proximity, the third magnet is in close proximity with the second magnet and the fourth magnet is in close proximity with the first magnet when the first and second movable bodies are in close proximity.

25

36. The exposure apparatus of claim 31 wherein a plurality of at least one of the third and fourth magnets are placed arranged spaced apart in a dimension equal to

each of the plurality of coils and larger in one of the first and second directions, within the second movable body.

37. The exposure apparatus of claim 31 wherein a  
5 plurality of the third and fourth magnets are provided in an arrangement where the third and fourth magnets are adjacent to each other in each of the first and second directions within the second movable body.

10 38. The exposure apparatus of claim 36 wherein as for a direction in which the first and second movable bodies are in close proximity, the first magnet is in close proximity with the fourth magnet and the second magnet is in close proximity with the third magnet when the first and second  
15 movable bodies are in close proximity.

39. The exposure apparatus of claim 31 wherein the driving device applies a driving force in the first direction to the first and second movers by supplying an  
20 excitation current to a first coil of the plurality of coils, and applies a driving force in the second direction to the first and second movers by supplying an excitation current to a second coil of the plurality of coils.

25 40. The exposure apparatus of claim 39 wherein the first and second coils are each arranged on layers different from each other within the base member.

41. The exposure apparatus of claim 39 wherein the first and second coils are arranged alternately on the same layer within the base member.

5           42. An exposure method irradiating an energy beam and forming a pattern on an object, the method comprising:  
            driving a first movable body using a stator including a plurality of coils arranged within a base member and a first mover including at least one first magnet and at  
10 least one second magnet provided within the first movable body that moves along a plane with facing the plurality of coils, and driving a second movable body using the stator and a second mover including at least one third magnet and at least one fourth magnet provided within the second  
15 movable body that moves along a plane with facing the plurality of coils, wherein the first movable body and the second movable body become proximate to generate a driving force between each of the plurality of coils and only one of the first and third magnets, and a driving force between  
20 each of the plurality of coils and only one of the second and fourth magnets.

            43. The exposure method of claim 42 wherein a liquid is moved between the first and second movable bodies by  
25 driving the first and second movable bodies in a direction in close proximity of the first and second movable bodies while maintaining a close proximity state of the first movable body holding the object and the second movable body.

44. The exposure method of claim 42 wherein the first and the third magnets each face a different coil of the plurality of coils and the second and fourth magnets each face a different coil of the plurality of coils when the first and second movable bodies are in close proximity.

45. The exposure method of claim 42 wherein the first movable body is driven in a first direction with the first magnet and in a second direction intersecting the first direction with the second magnet, and the second movable body is driven in the first direction with the third magnet and in the second direction with the fourth magnet.

46. The exposure method of claim 45 wherein a space is provided, the space being one of a dimension equal to each of the plurality of coils and larger in a direction in one of the first and second directions between the first magnet and the third magnet, as well as a dimension equal to each of the plurality of coils and larger in the direction in one of the first and second directions between the second magnet and the fourth magnet when the first and second movable bodies are in close proximity.

47. The exposure method of claim 45 wherein a plurality of at least one of the first and second magnets are placed arranged spaced apart in a dimension equal to each of the plurality of coils and larger in one of the first and second directions, within the first movable body.

48. The exposure method of claim 45 wherein a plurality of the first and second magnets are provided in an arrangement where the first and second magnets are adjacent to each other in each of the first and second directions  
5 within the first movable body.

49. The exposure method of claim 47 wherein as for a direction in which the first and second movable bodies are in close proximity, the third magnet is in close proximity  
10 with the second magnet and the fourth magnet is in close proximity with the first magnet when the first and second movable bodies are in close proximity.

50. The exposure method of claim 45 wherein a plurality of at least one of the third and fourth magnets  
15 are placed arranged spaced apart in a dimension equal to each of the plurality of coils and larger in one of the first and second directions, within the second movable body.

51. The exposure method of claim 45 wherein a plurality of the third and fourth magnets are provided in an arrangement where the third and fourth magnets are adjacent to each other in each of the first and second directions  
20 within the second movable body.

25

52. The exposure method of claim 50 wherein as for a direction in which the first and second movable bodies are in close proximity, the first magnet is in close proximity with the fourth magnet and the second magnet is in close

proximity with the third magnet when the first and second movable bodies are in close proximity.

53. The exposure method of claim 45 wherein a driving  
5 force is applied in the first direction to the first and  
second movers by supplying an excitation current to a first  
coil of the plurality of coils, and a driving force is  
applied in the second direction to the first and second  
movers by supplying an excitation current to a second coil  
10 of the plurality of coils.

54. The exposure method of claim 53 wherein the first  
and second coils are each arranged on layers different from  
each other within the base member.  
15

55. The exposure method of claim 53 wherein the first  
and second coils are arranged alternately on the same layer  
within the base member.

20 56. A device manufacturing method, including:  
forming a pattern on an object with the exposure  
method of claim 42, and  
developing the object on which a pattern is formed.

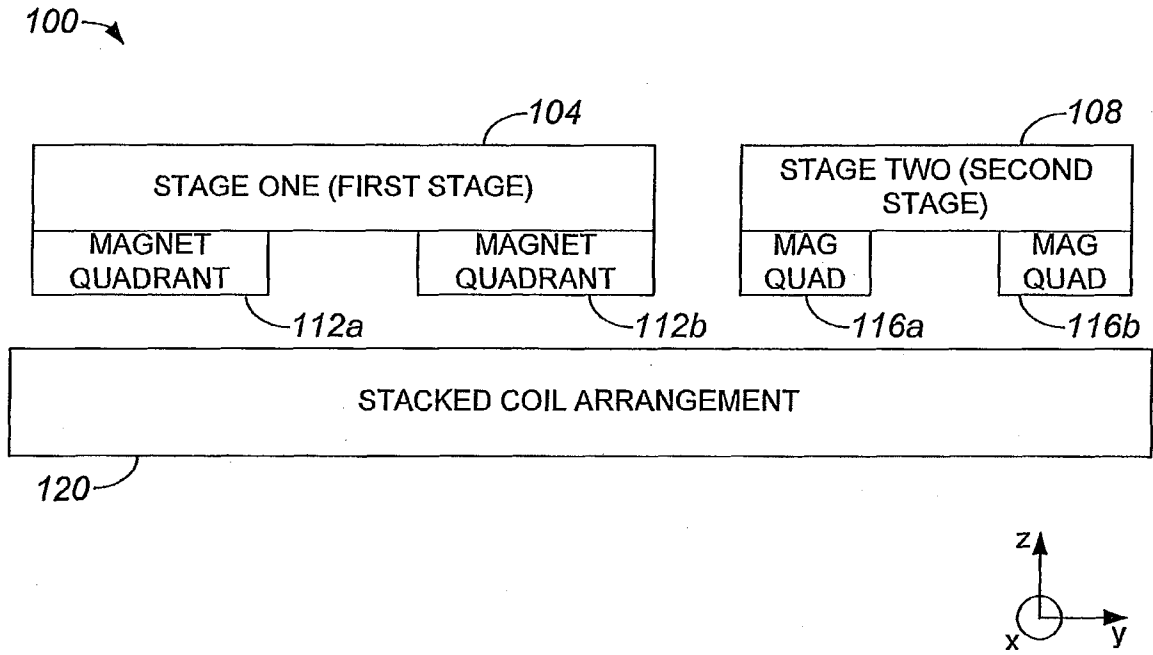

FIG. 1

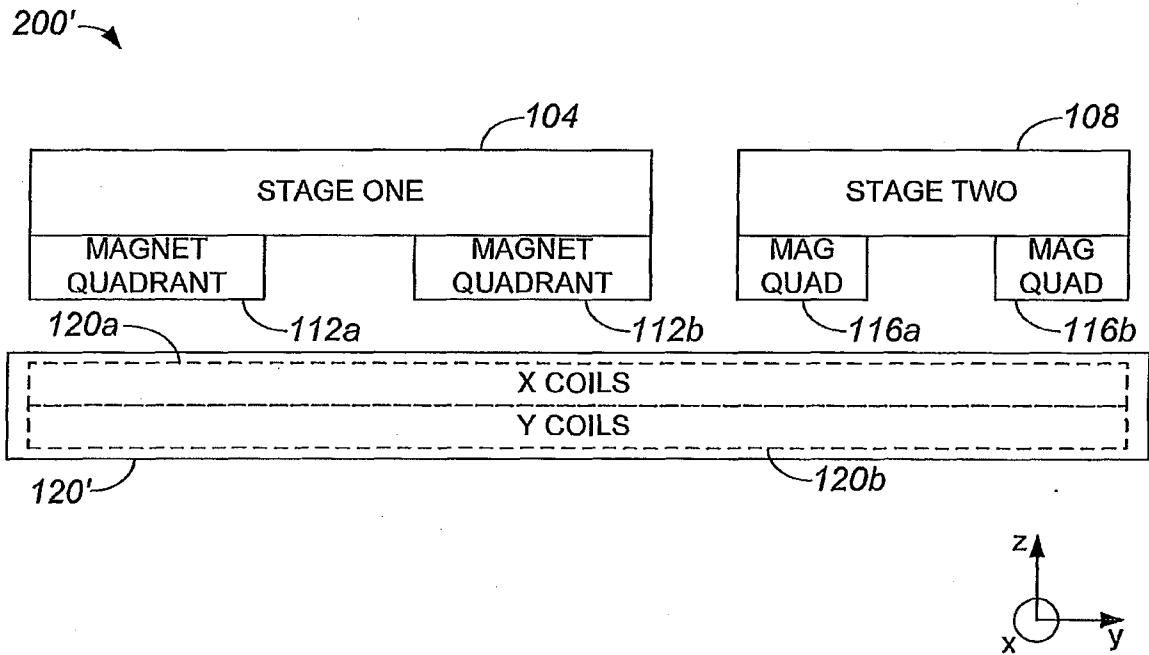

FIG. 2A

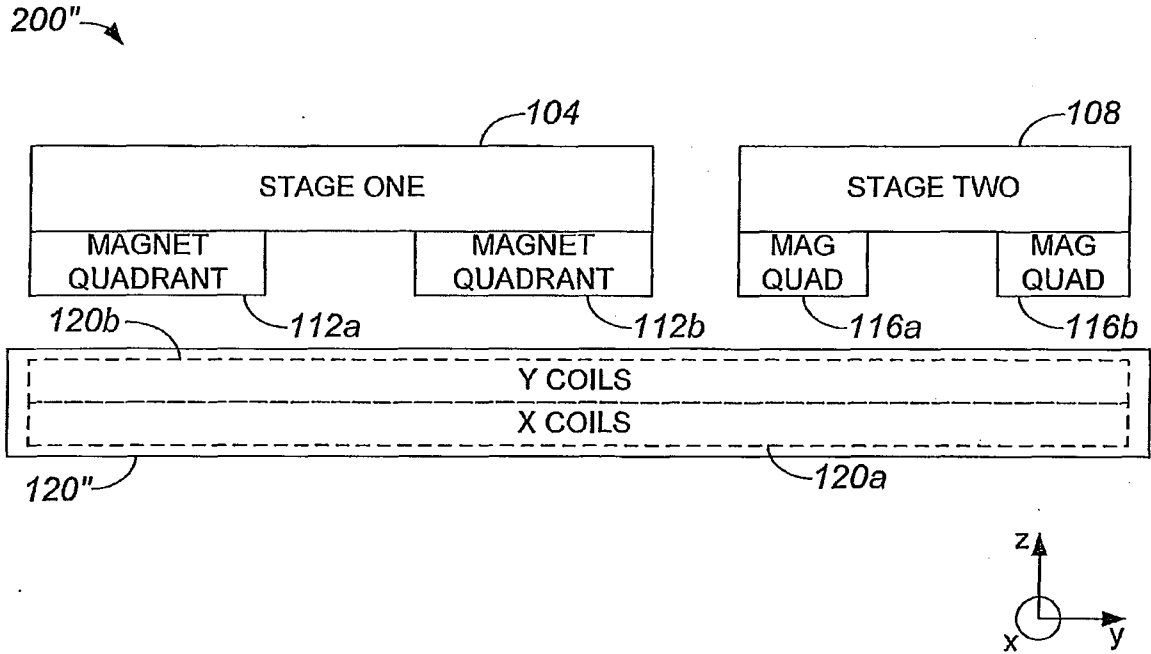

FIG. 2B

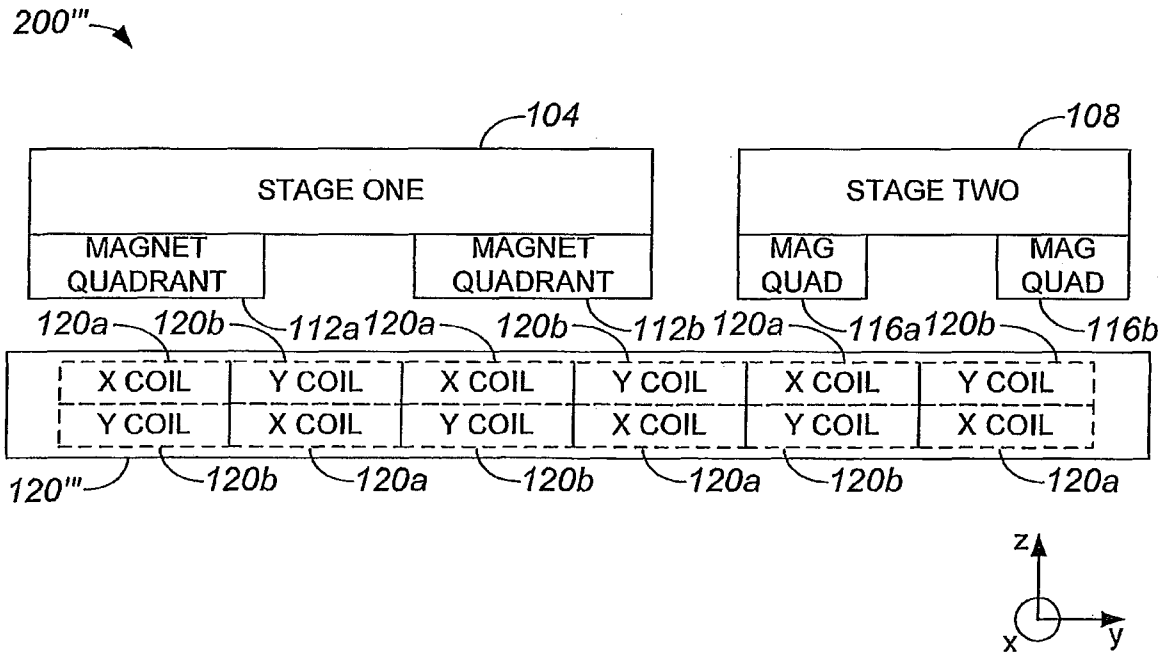

FIG. 2C

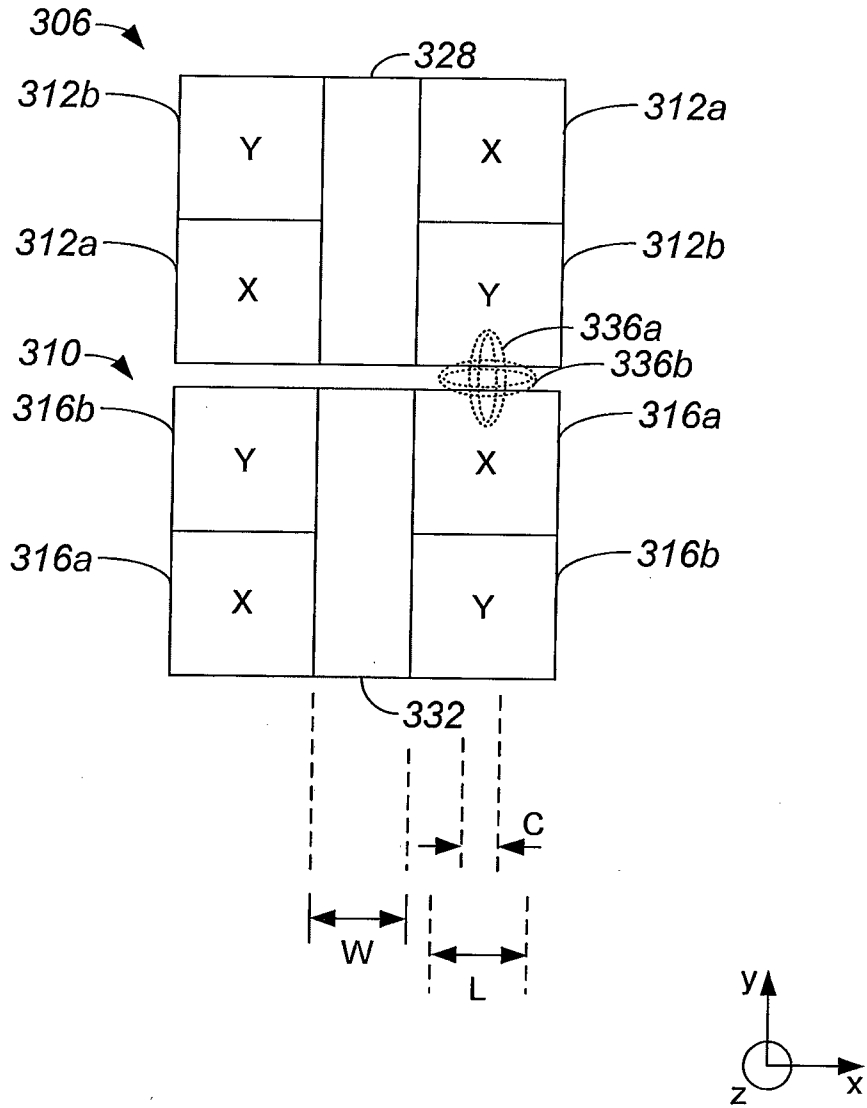

FIG. 3A

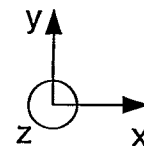
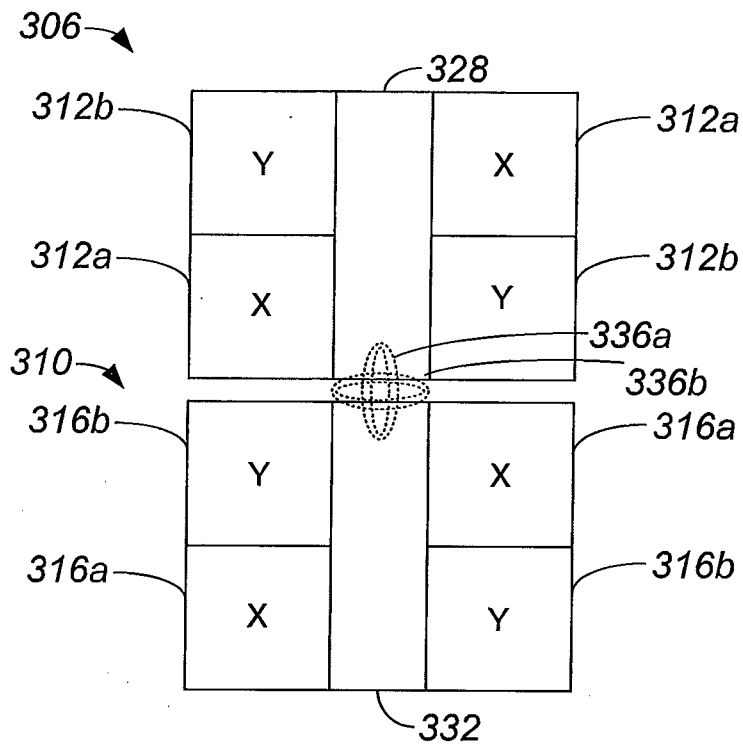

FIG. 3B

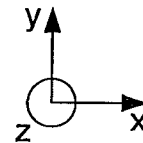
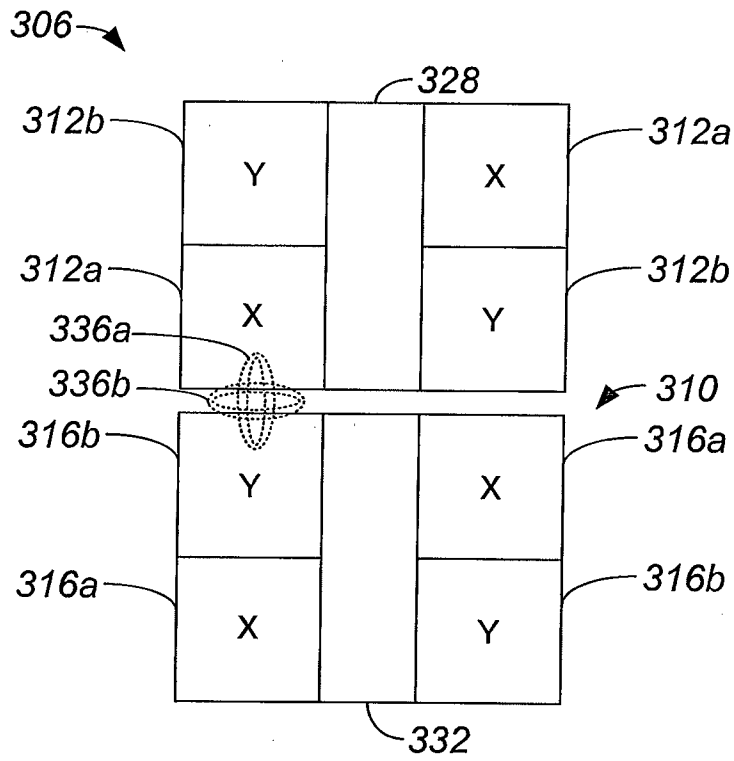

FIG. 3C

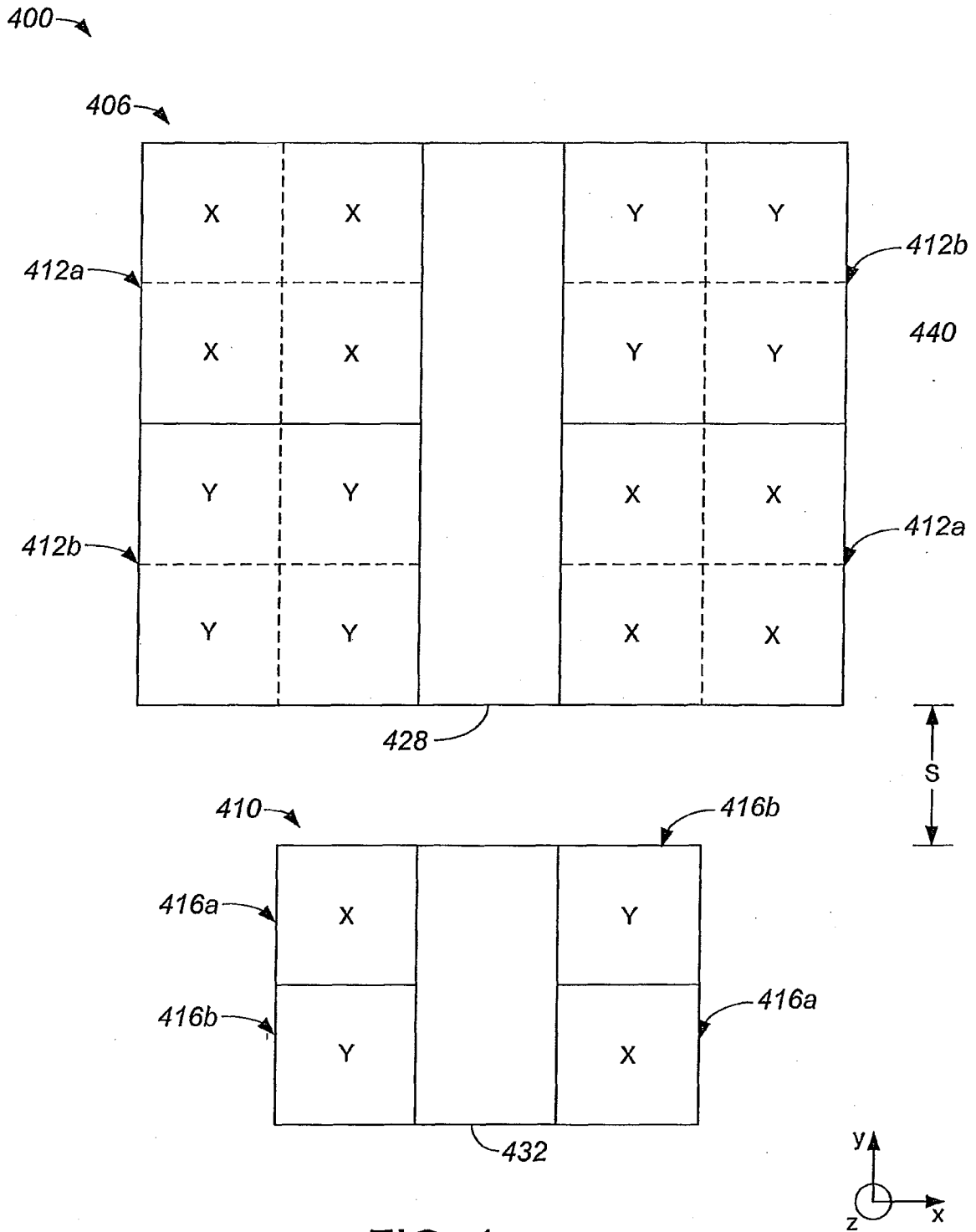

FIG. 4

7/25

564 →

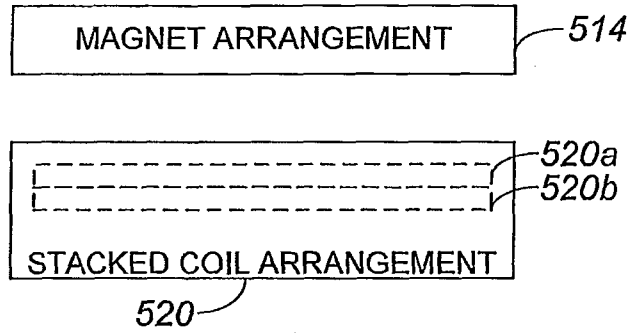

FIG. 5

668 →

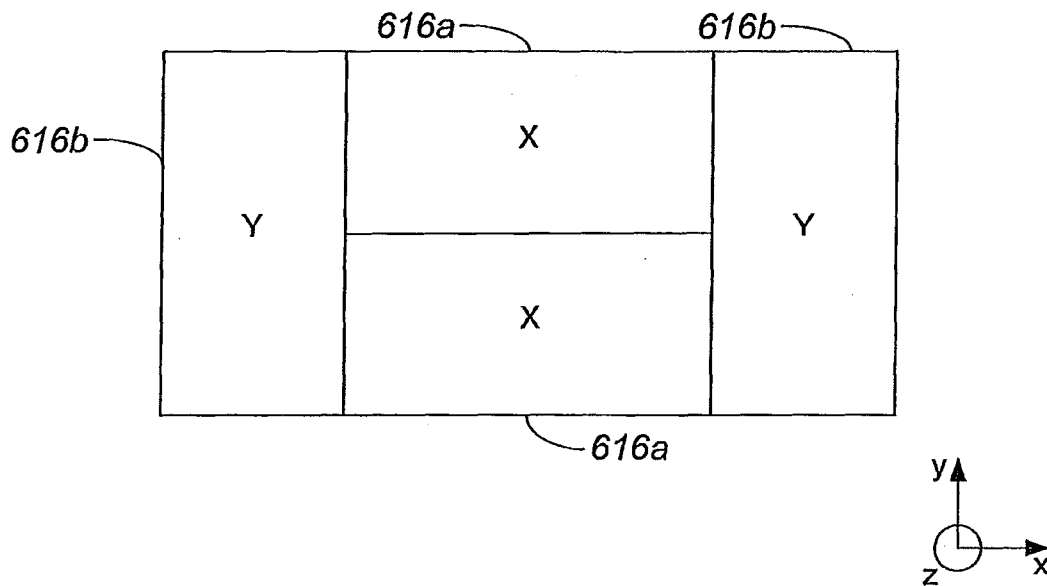

FIG. 6A

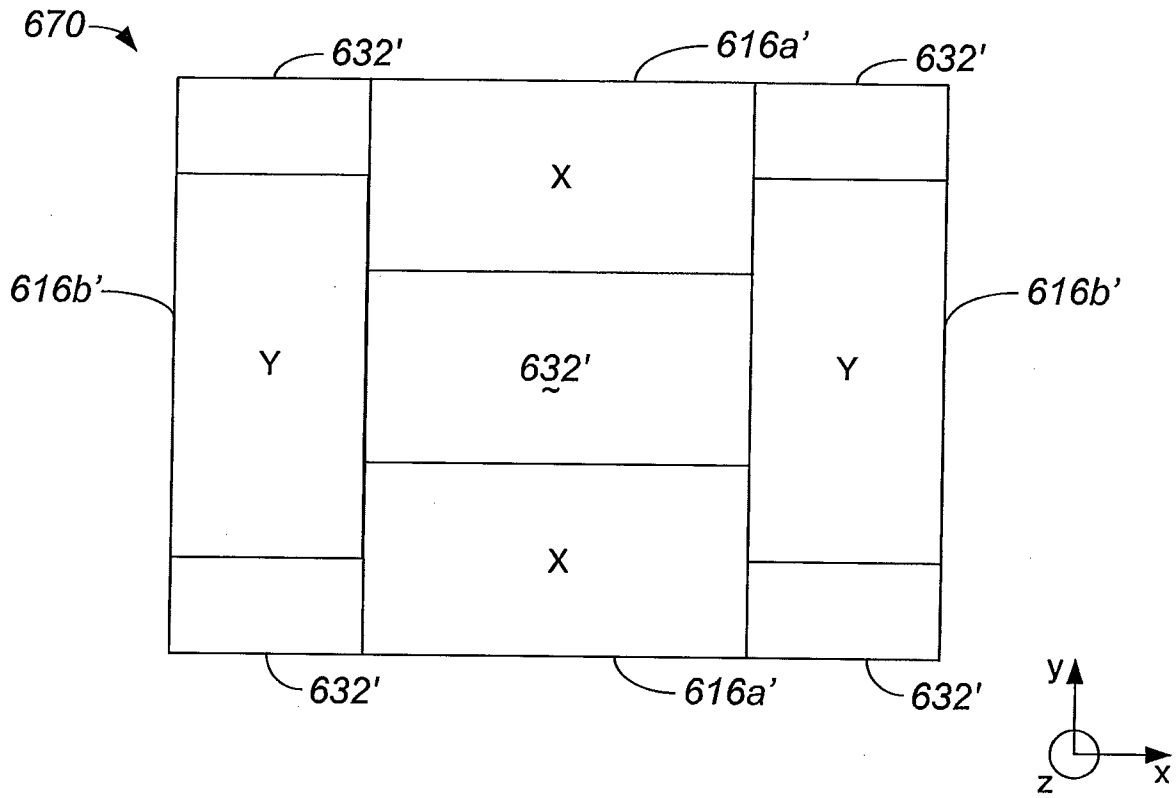

FIG. 6B

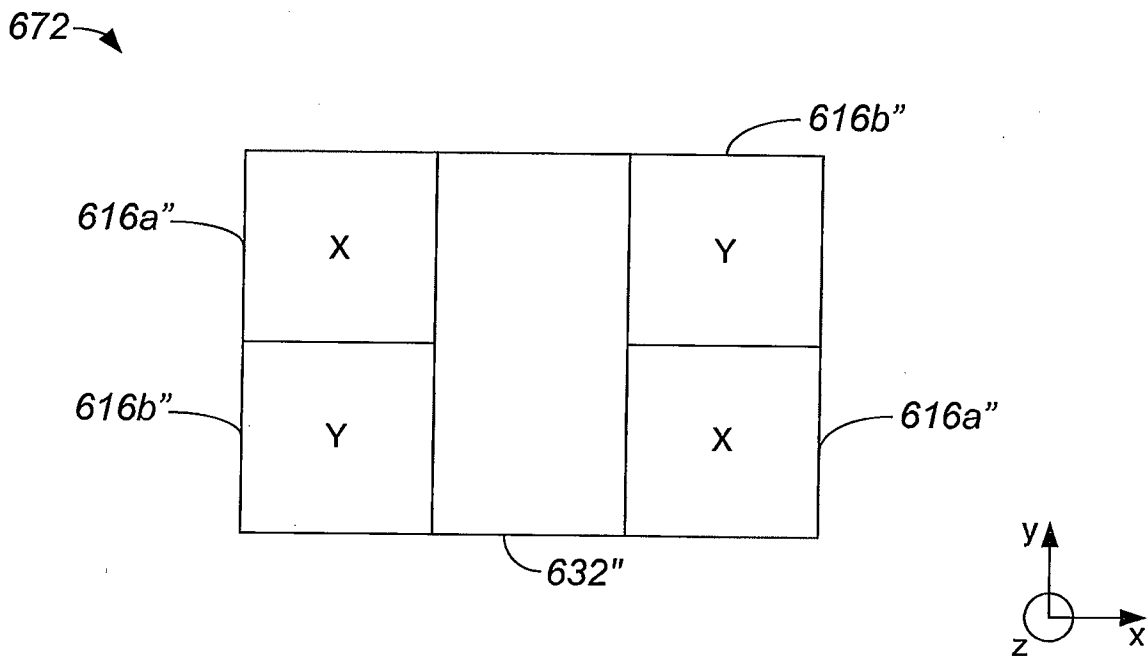

FIG. 6C

9/25

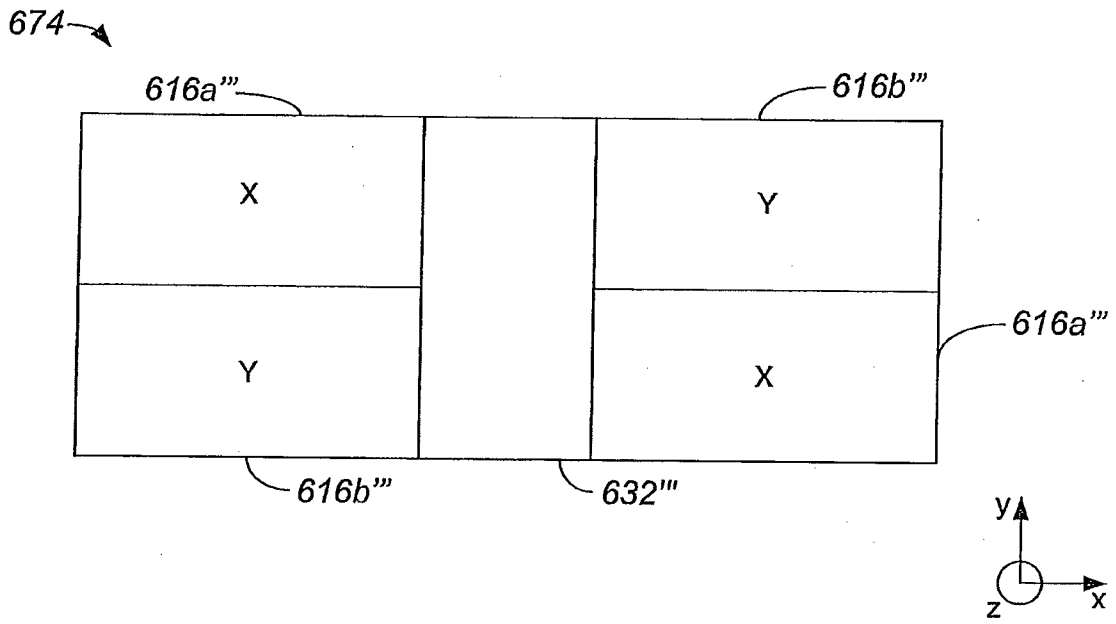

FIG. 6D

10/25

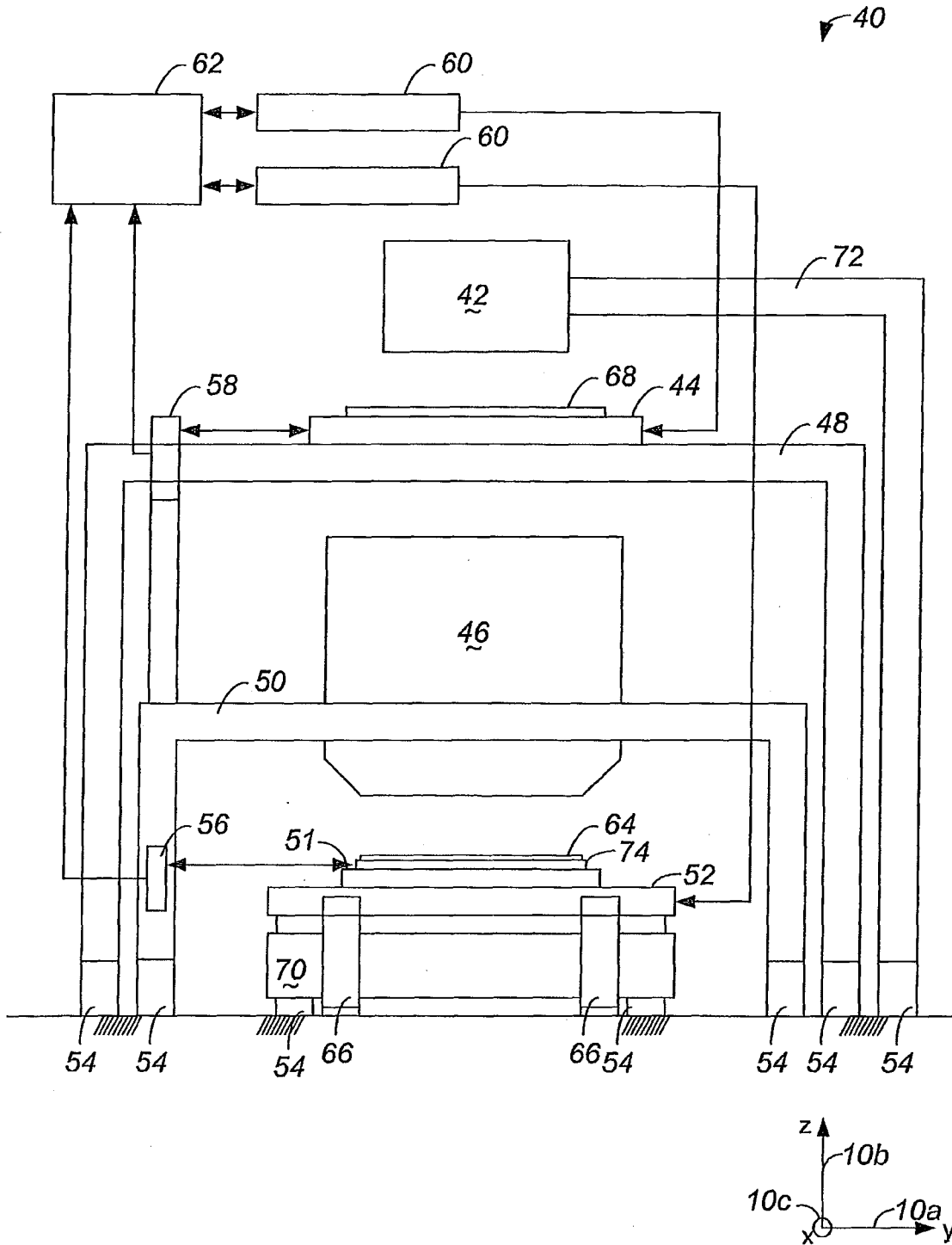

FIG. 7

11/25

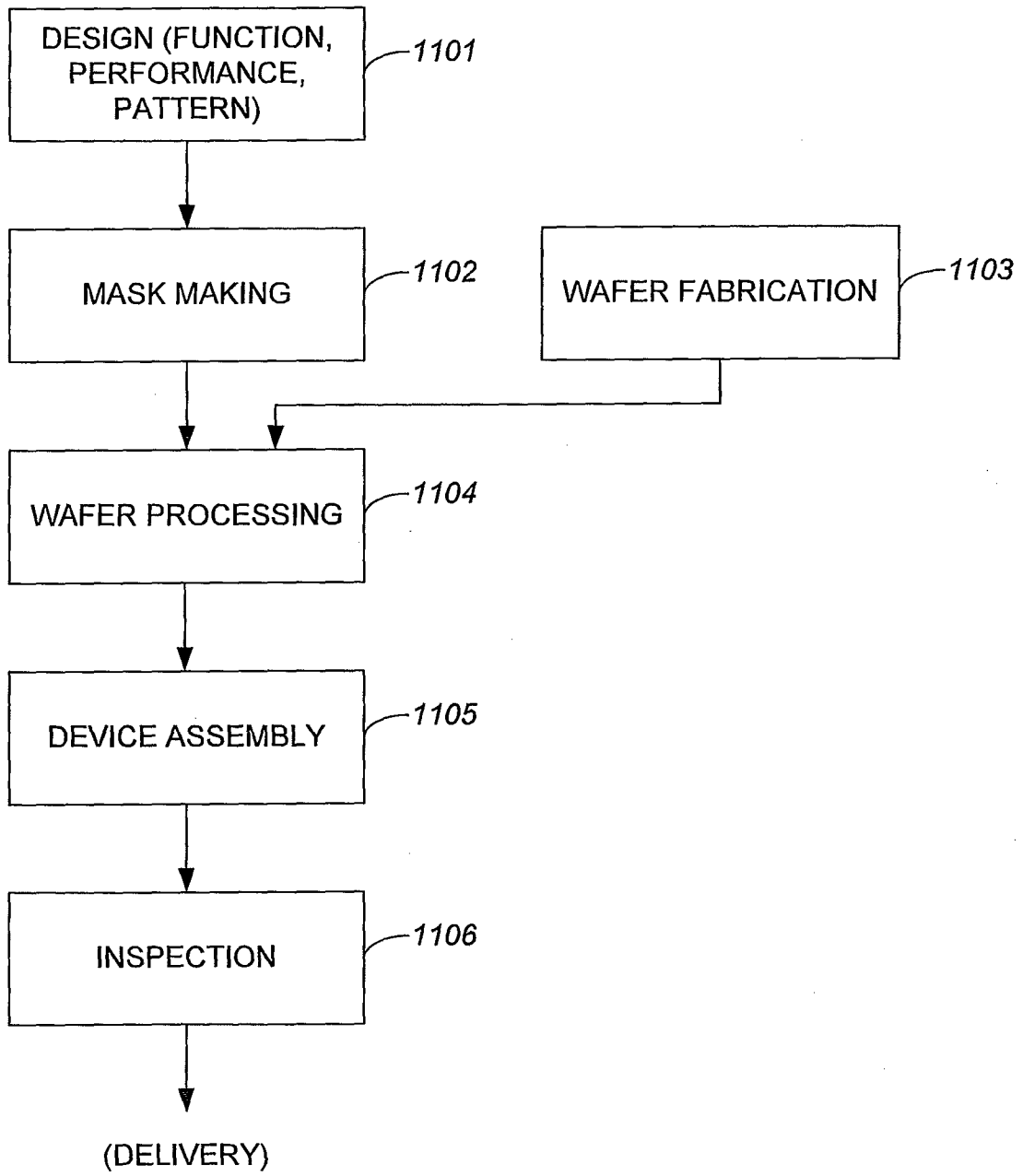

FIG. 8

12/25

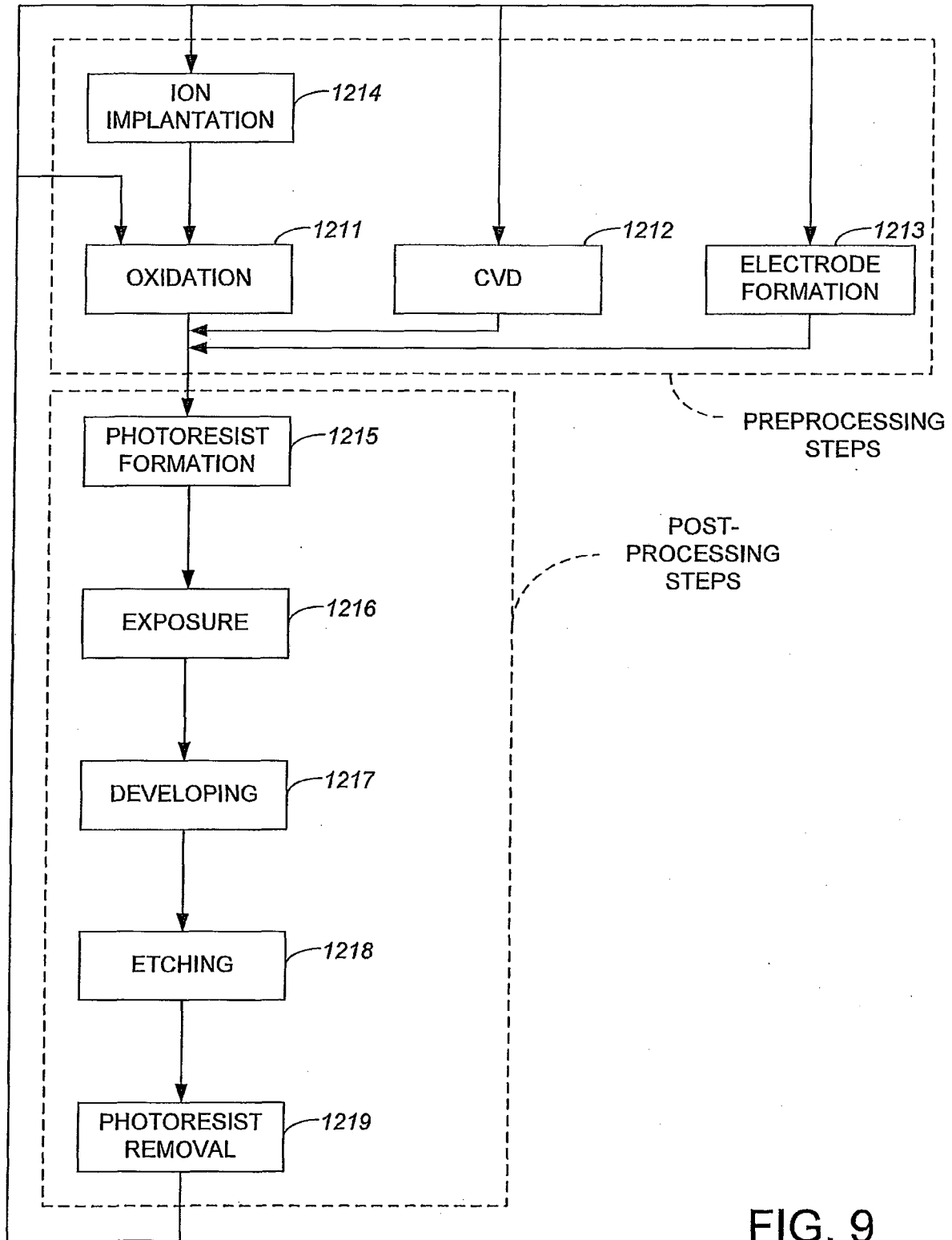

FIG. 9

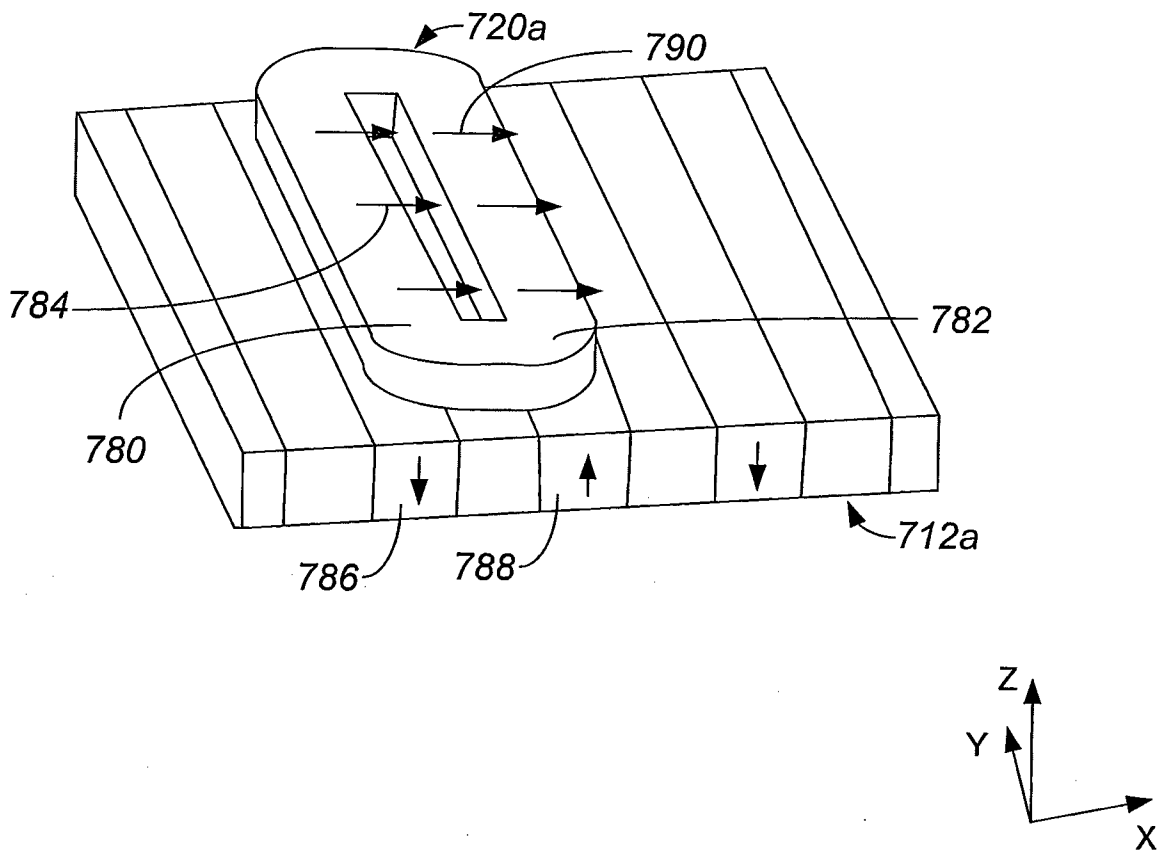

FIG. 10

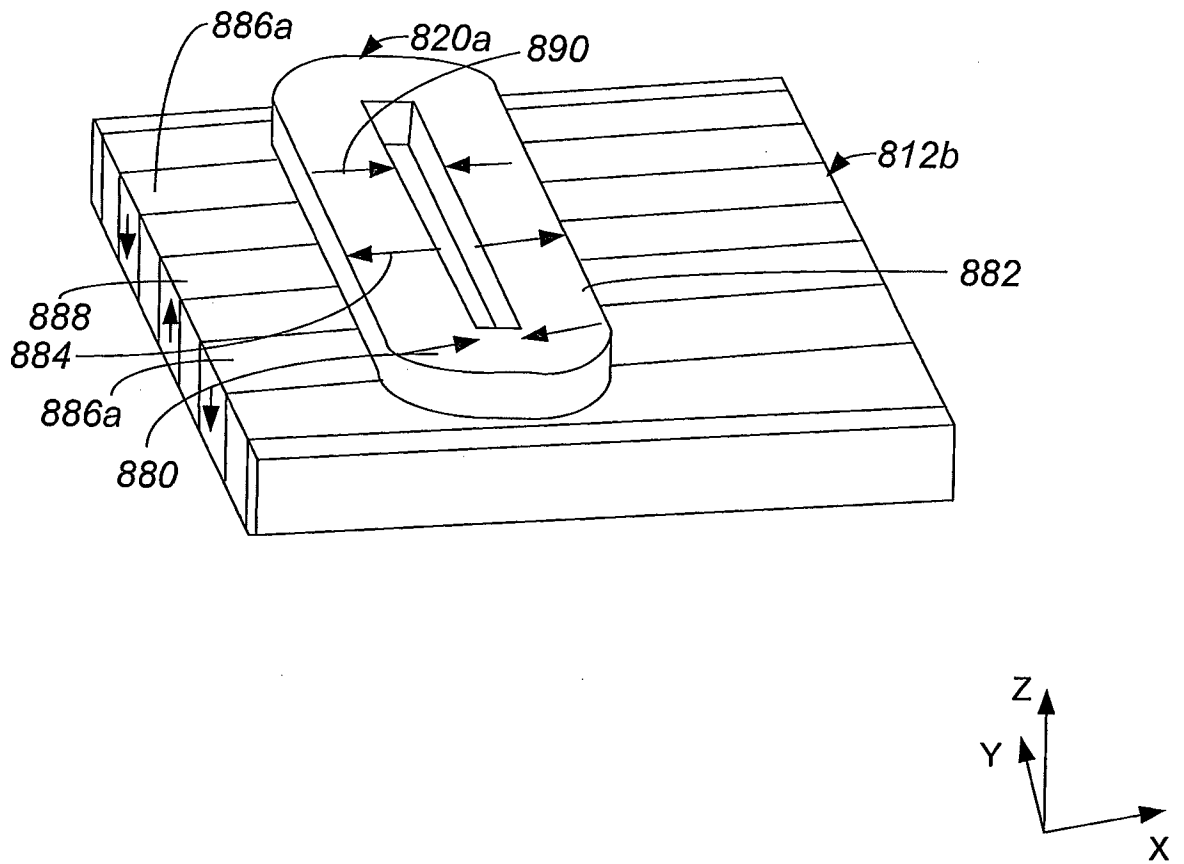

FIG. 11

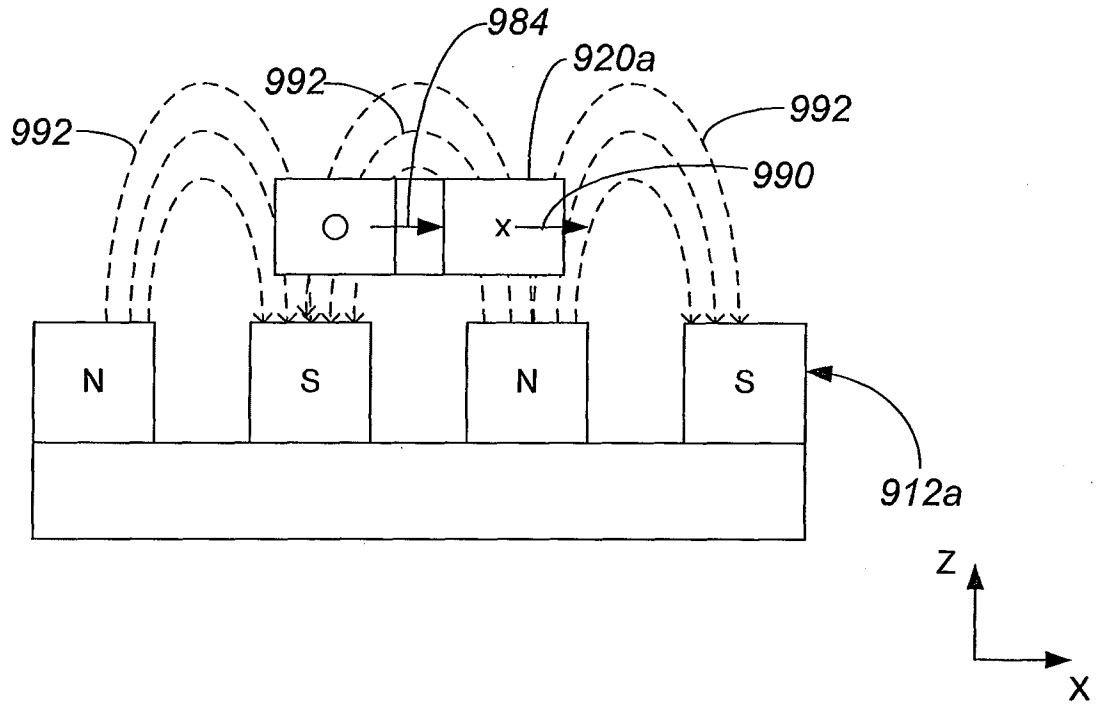

FIG. 12

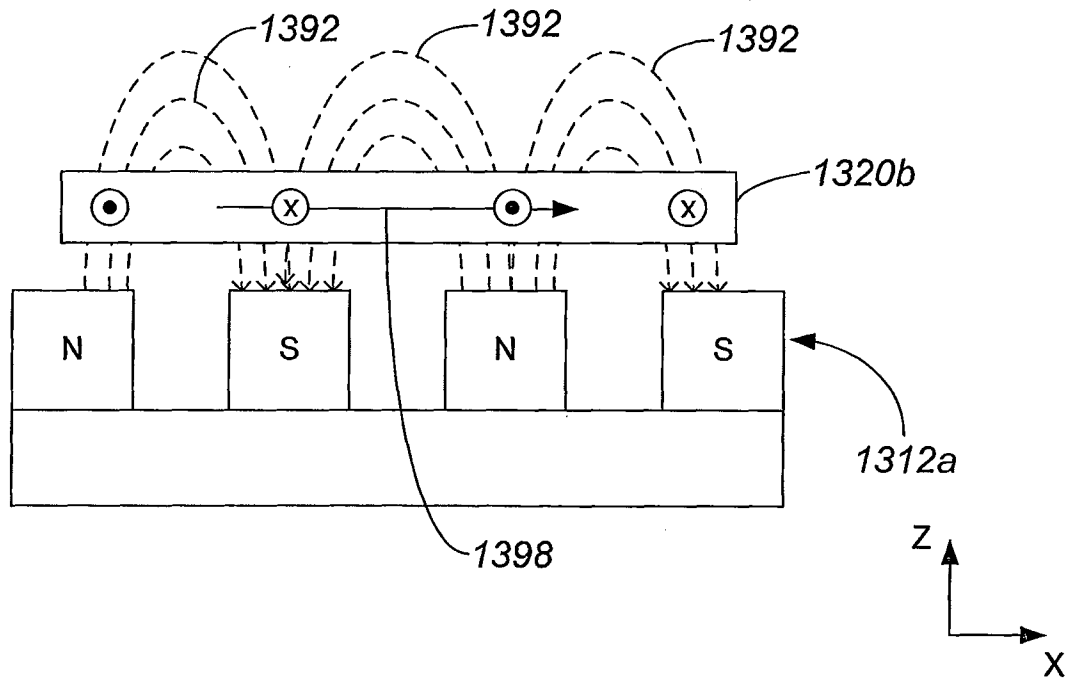

FIG. 13

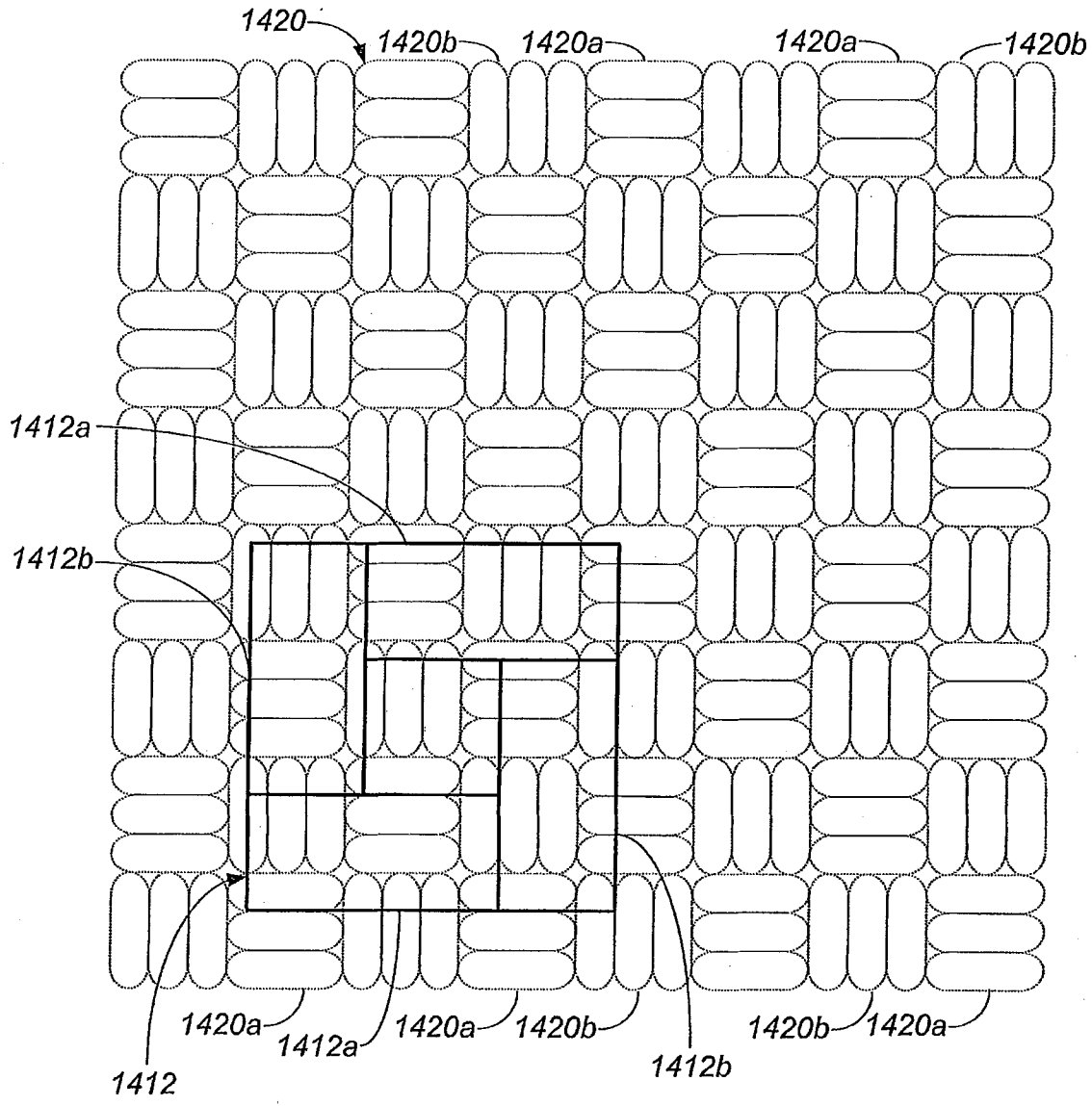

FIG. 14

1512 →

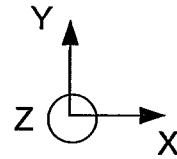
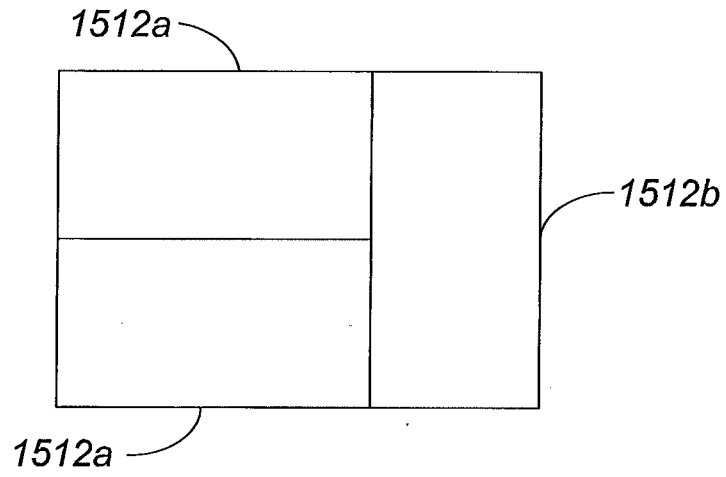

FIG. 15

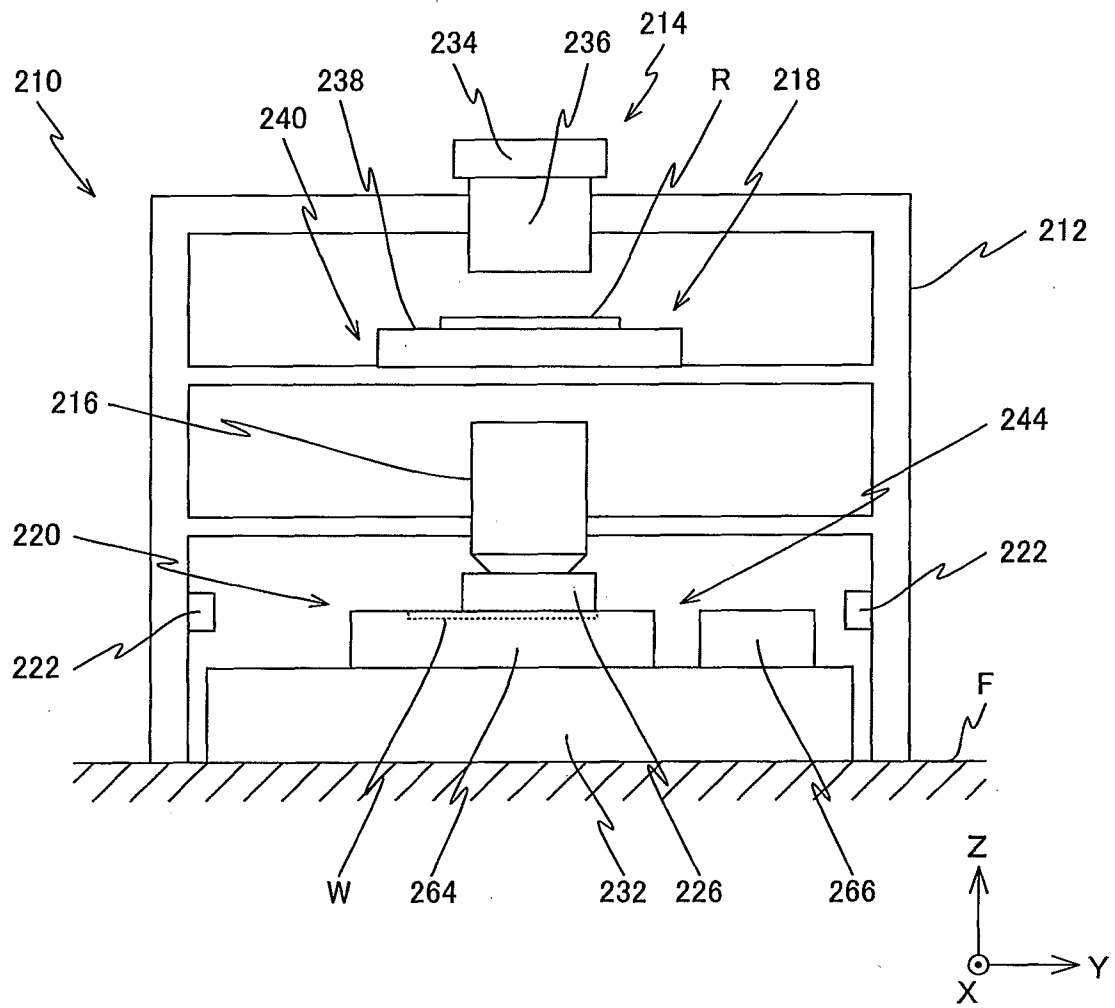

FIG. 16

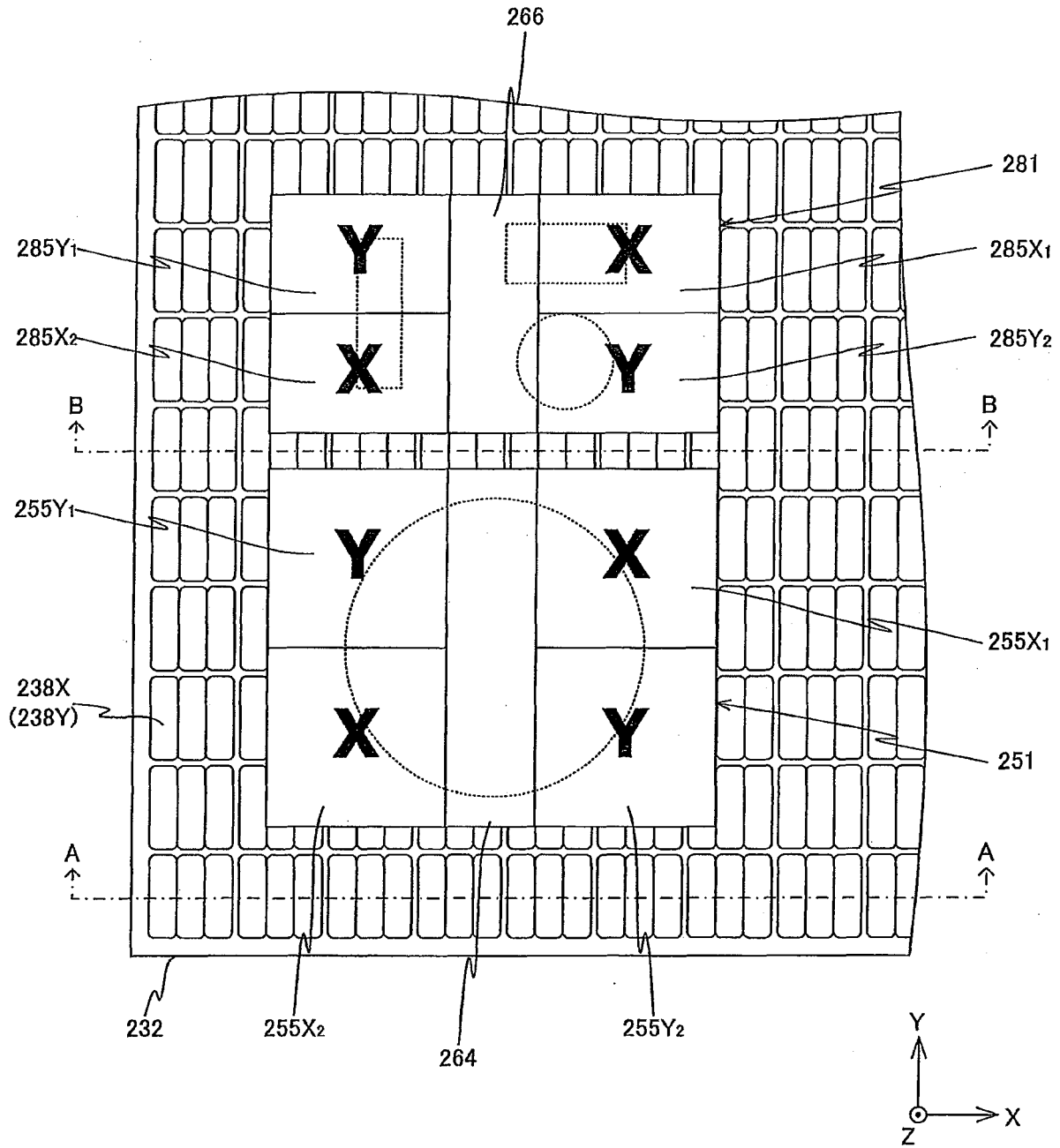

FIG. 17

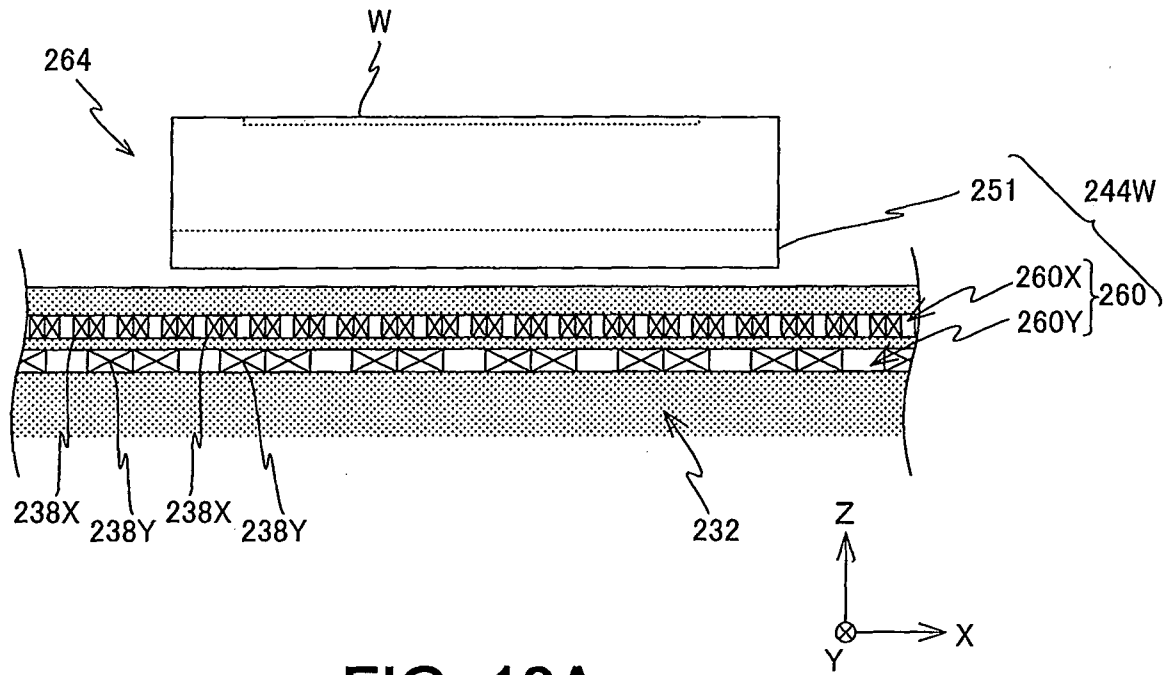

FIG. 18A

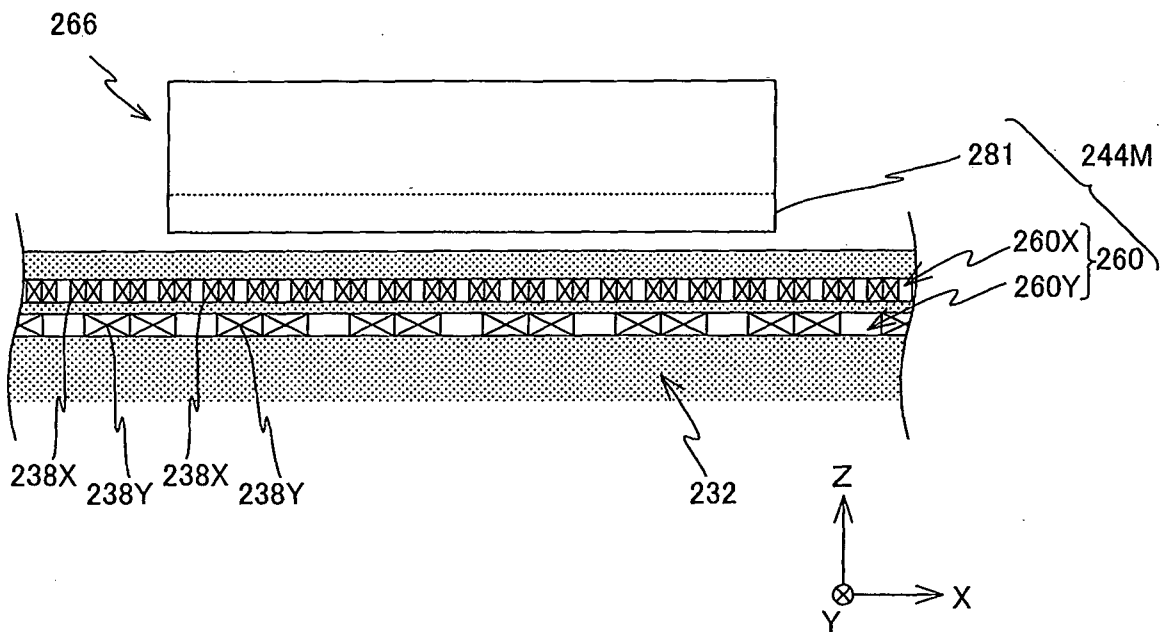

FIG. 18B

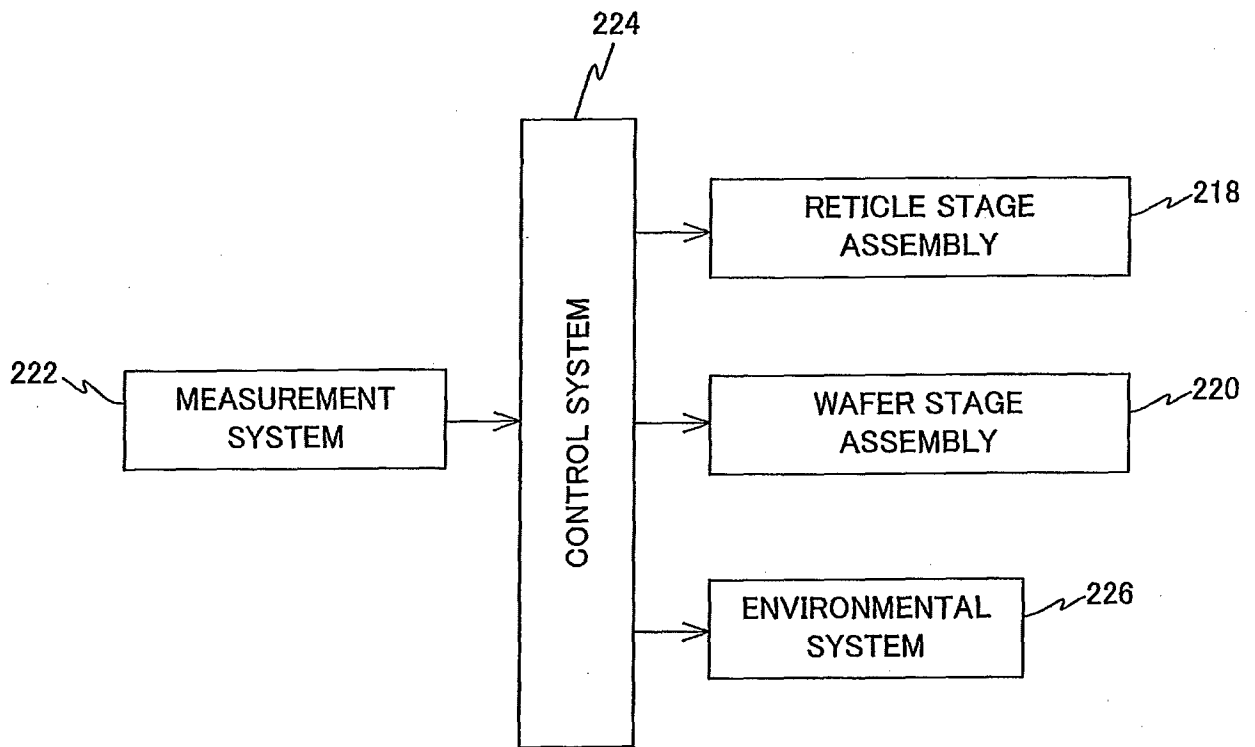

FIG. 19

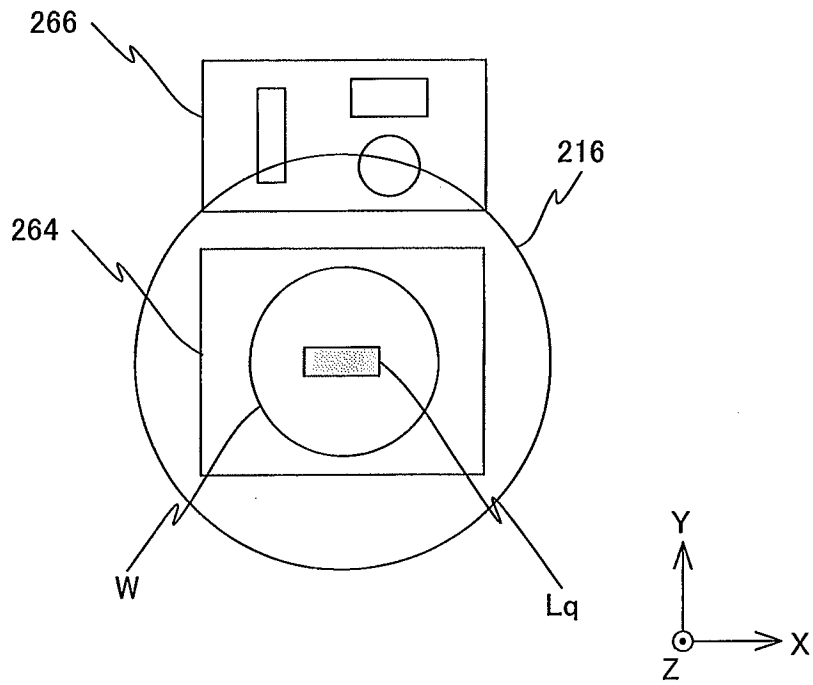

FIG. 20A

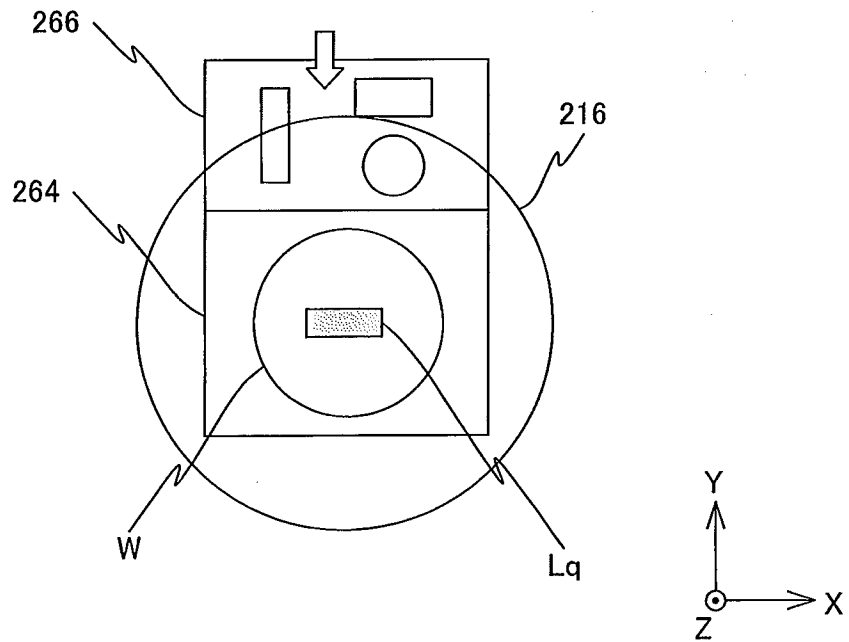

FIG. 20B

23/25

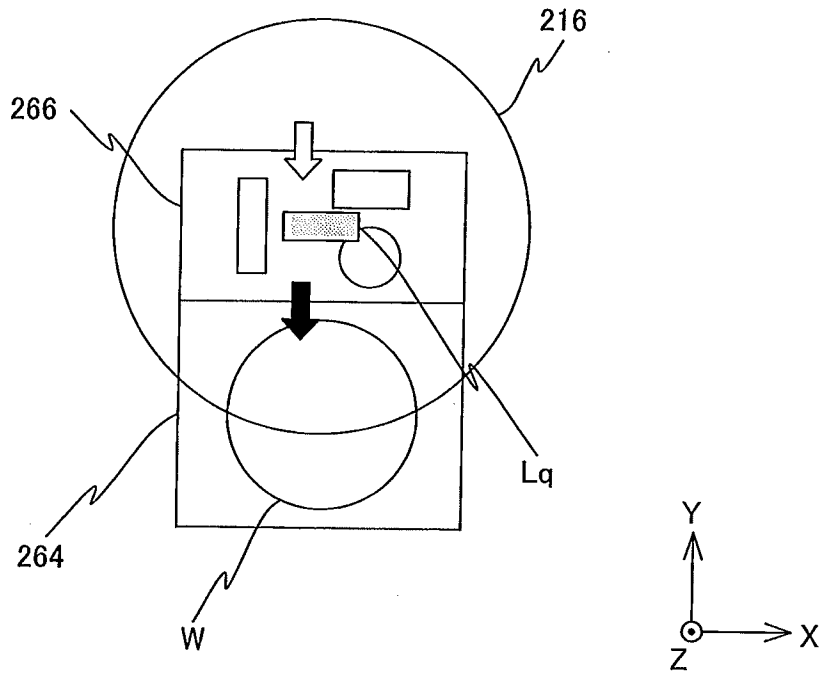

FIG. 20C

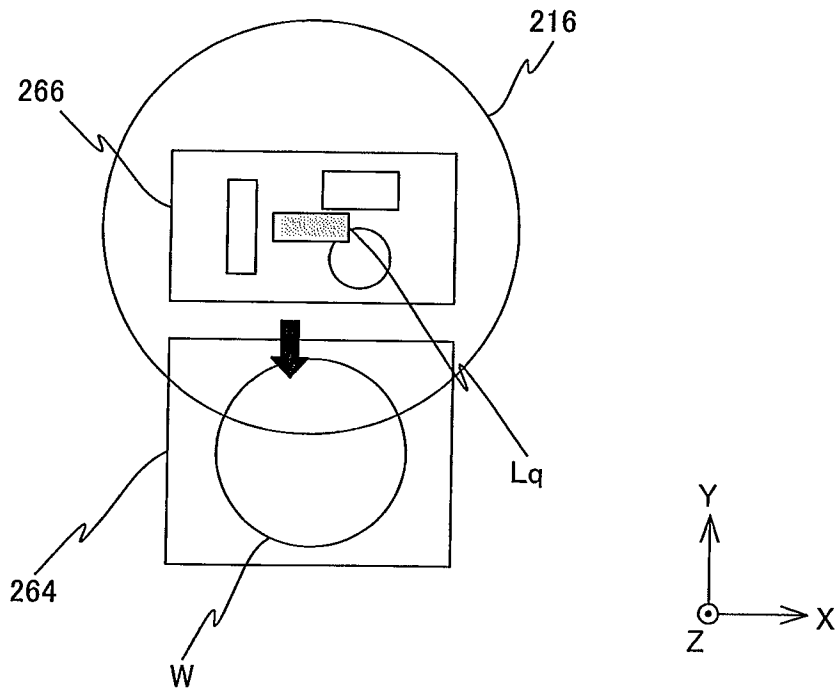

FIG. 20D

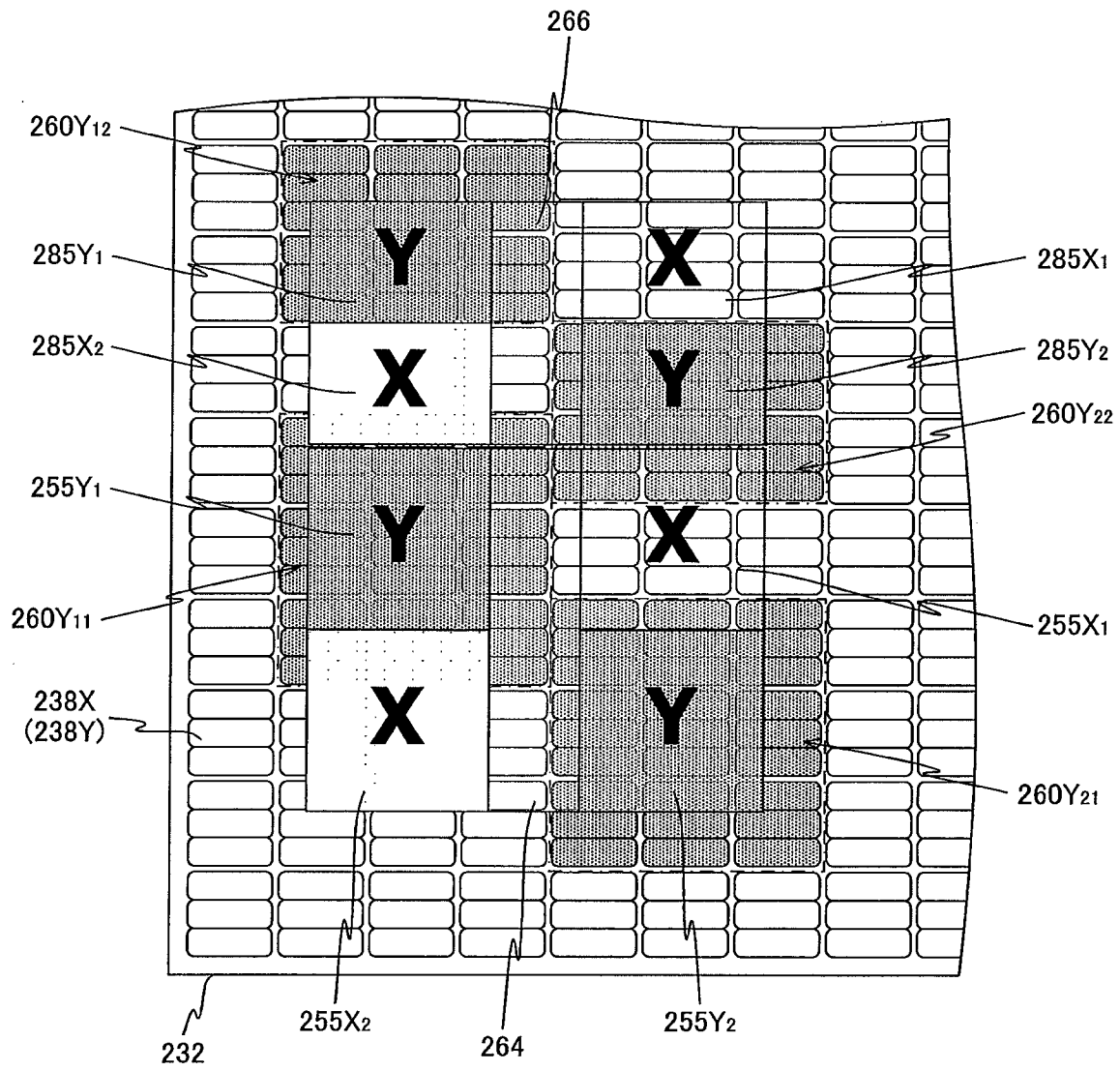

FIG. 21

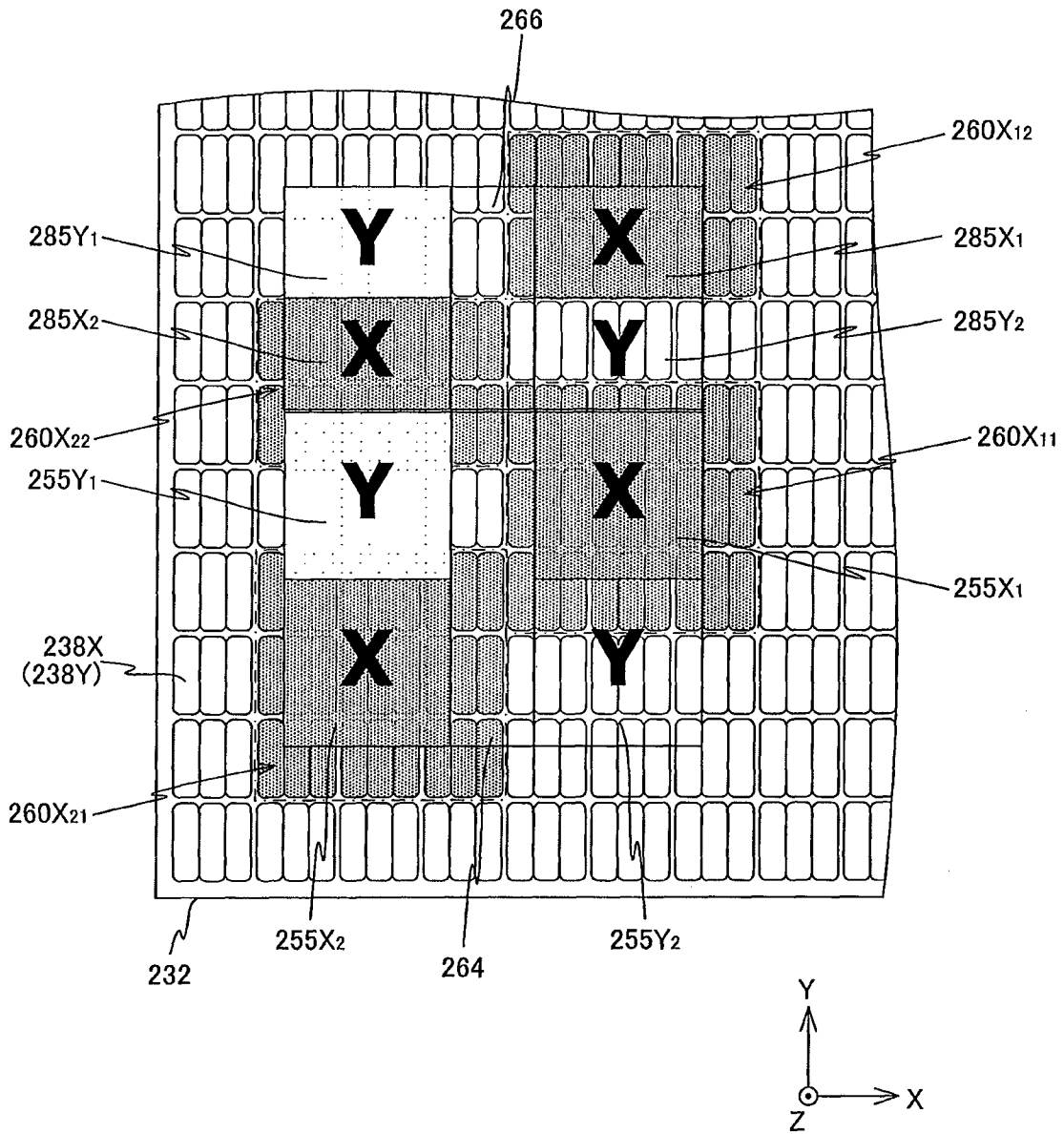

FIG. 22

INTERNATIONAL SEARCH REPORT

International application No  
PCT/JP2012/066823

A. CLASSIFICATION OF SUBJECT MATTER  
INV. G03F7/20  
ADD.  
According to International Patent Classification (IPC) or to both national classification and IPC

B. FIELDS SEARCHED  
Minimum documentation searched (classification system followed by classification symbols)  
G03F H02K H01L

Documentation searched other than minimum documentation to the extent that such documents are included in the fields searched

Electronic data base consulted during the international search (name of data base and, where practicable, search terms used)  
EPO-Internal, WPI Data

C. DOCUMENTS CONSIDERED TO BE RELEVANT

Category*	Citation of document, with indication, where appropriate, of the relevant passages	Relevant to claim No.
X A	WO 00/10242 A1 (NIPPON KOGAKU KK [JP]; HAZELTON ANDREW J [US]) 24 February 2000 (2000-02-24) abstract figure 8B page 1, line 6 - line 7 page 18, line 14 - line 20	12-18,26  1,19,27, 28,42,56
X A	JP 2007 185086 A (KOREA ELECTROTECH RES INST) 19 July 2007 (2007-07-19) abstract figures 1-4 paragraph [0002]	12,18,26  1,13,19, 27,28, 42,56
	----- -/--	

Further documents are listed in the continuation of Box C.

See patent family annex.

\* Special categories of cited documents :

"A" document defining the general state of the art which is not considered to be of particular relevance

"E" earlier application or patent but published on or after the international filing date

"L" document which may throw doubts on priority claim(s) or which is cited to establish the publication date of another citation or other special reason (as specified)

"O" document referring to an oral disclosure, use, exhibition or other means

"P" document published prior to the international filing date but later than the priority date claimed

"T" later document published after the international filing date or priority date and not in conflict with the application but cited to understand the principle or theory underlying the invention

"X" document of particular relevance; the claimed invention cannot be considered novel or cannot be considered to involve an inventive step when the document is taken alone

"Y" document of particular relevance; the claimed invention cannot be considered to involve an inventive step when the document is combined with one or more other such documents, such combination being obvious to a person skilled in the art

"&" document member of the same patent family

Date of the actual completion of the international search  18 September 2012	Date of mailing of the international search report  05/10/2012
--	--

Name and mailing address of the ISA/ European Patent Office, P.B. 5818 Patentlaan 2 NL - 2280 HV Rijswijk Tel. (+31-70) 340-2040, Fax: (+31-70) 340-3016	Authorized officer  Andersen, Ole
--	---

## INTERNATIONAL SEARCH REPORT

International application No  
PCT/JP2012/066823

C(Continuation). DOCUMENTS CONSIDERED TO BE RELEVANT		
Category*	Citation of document, with indication, where appropriate, of the relevant passages	Relevant to claim No.
X	US 2006/097585 A1 (ASANO TOSIYA [JP] TOSIYA ASANO [JP]) 11 May 2006 (2006-05-11)	12,18,26
A	abstract figures 8A,8B paragraphs [0002], [0028] - [0030] -----	1,13,19, 27,28, 42,56
X	WO 2006/075291 A2 (KONINKL PHILIPS ELECTRONICS NV [NL]; COMPTER JOHAN C [NL]; FRISSEN PET) 20 July 2006 (2006-07-20)	12,18,26
A	abstract figures 8A,8B paragraphs [0002], [0028] - [0030] -----	1,13,19, 27,28, 42,56

# INTERNATIONAL SEARCH REPORT

Information on patent family members

International application No

PCT/JP2012/066823

Patent document cited in search report	Publication date	Patent family member(s)	Publication date
WO 0010242	A1	24-02-2000	
		AU 5675699 A	06-03-2000
		JP 2002524009 A	30-07-2002
		US 6097114 A	01-08-2000
		WO 0010242 A1	24-02-2000
-----			
JP 2007185086	A	19-07-2007	NONE
-----			
US 2006097585	A1	11-05-2006	
		JP 4566697 B2	20-10-2010
		JP 2006136154 A	25-05-2006
		US 2006097585 A1	11-05-2006
		US 2008170214 A1	17-07-2008
-----			
WO 2006075291	A2	20-07-2006	
		CN 101107571 A	16-01-2008
		EP 1842101 A2	10-10-2007
		JP 2008527964 A	24-07-2008
		KR 20070099609 A	09-10-2007
		US 2008203828 A1	28-08-2008
		WO 2006075291 A2	20-07-2006
-----			