

Nov. 6, 1934.

J. DUNNER

1,979,321

ARTIFICIAL EYES FOR DOLLS, TOYS, AND THE LIKE

Filed Jan. 6, 1932

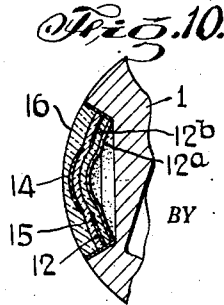
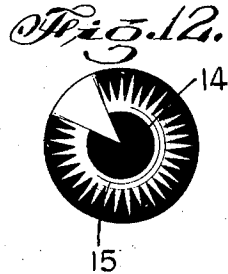
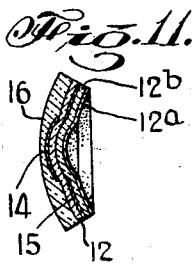
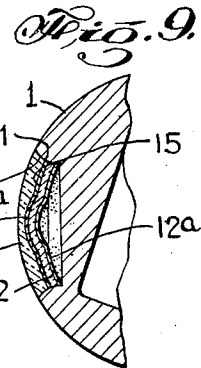
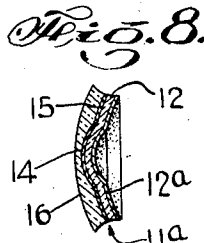
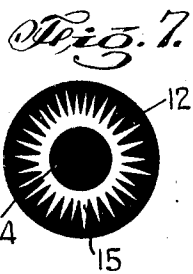
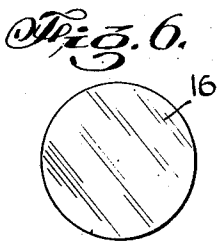
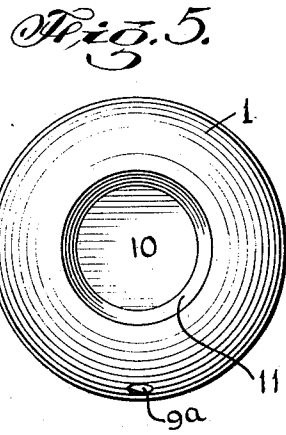
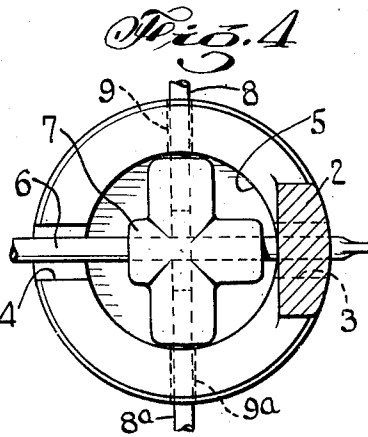
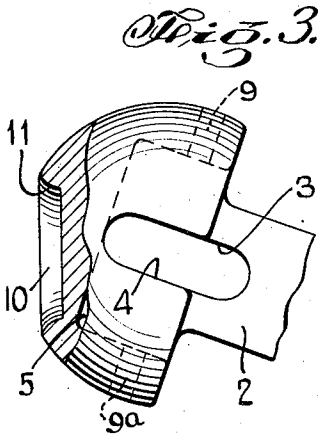
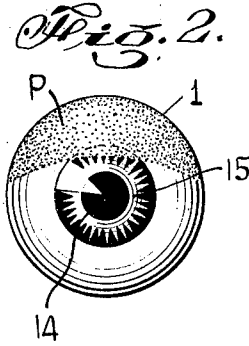
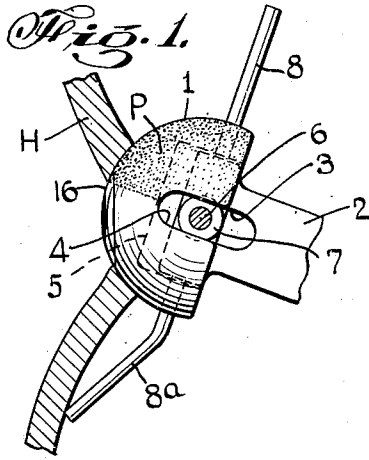

Julius Dunner
INVENTOR.

BY Mock & Blum
ATTORNEYS.

UNITED STATES PATENT OFFICE

1,979,321

ARTIFICIAL EYES FOR DOLLS, TOYS, AND THE LIKE

Julius Dunner, Brooklyn, N. Y., assignor to Ideal Novelty & Toy Co., Brooklyn, N. Y., a corporation of New York

Application January 6, 1932, Serial No. 584,982

10 Claims. (Cl. 46—40)

My invention relates to a new and improved artificial eye.

One of the objects of my invention is to provide an improved artificial eye for use in dolls, toys, and the like.

Another object of my invention is to provide an artificial eye which can be simply and economically manufactured and which shall be of solid and durable construction.

Another object of my invention is to provide an artificial eye which can be made wholly of celluloid or other material which can be readily formed into shape.

Another object of my invention is to provide an artificial eye which shall have a life-like appearance.

Other objects of my invention will be set forth in the following description and drawing which illustrates a preferred embodiment thereof, it being understood that the above general statement of the objects of my invention is intended merely to generally explain the same and not to limit it in any manner.

Fig. 1 is a side elevation partially in section, the supporting arm for the eyeball member being shown broken away.

Fig. 2 is a front elevation of the improved eye.

Fig. 3 is a side elevation partially in section of the eyeball member with the insert removed.

Fig. 4 is a rear elevation of Fig. 3.

Fig. 5 is a front elevation of Fig. 3.

Fig. 6 is an elevation of a disc made of celluloid or similar material, said disc forming the front member of the insert.

Fig. 7 is a front elevation of a disc of celluloid or other flexible material on which the representation of the pupil and of the iris is painted or printed or otherwise suitably depicted.

Fig. 8 is a vertical central section showing how the insert is prepared by combining the members shown in Fig. 6 and Fig. 7.

Fig. 9 is a vertical central section showing the insert assembled with the eyeball member.

Fig. 10 is a view similar to Fig. 9 and showing a modified form of the invention.

Fig. 11 is a vertical central sectional view of the modified insert shown in Fig. 10.

Fig. 12 shows the modified pupil and iris member which is used in the embodiment shown in Figs. 10 and 11.

Artificial eyes of various types have been heretofore proposed for use in manufacturing dolls, toys, and the like. The manufacture of such eyes has been either expensive, or else such eyes have been of relatively fragile construction.

According to my invention, a life-like and durable eye can be manufactured at relatively low cost.

Referring to Fig. 1, the invention is illustrated in connection with a doll-head H. The eyeball member 1 preferably has the general outer shape of a hemisphere and it can be made of any suitable transparent or other material which can be readily shaped, such as metal or celluloid. The eyeball member 1 is rigid and it can be made either from a substantially colorless and transparent celluloid, or from celluloid having a light gray color. In the latter case, the eyeball member 1 is translucent so that it permits some light to pass through. However, the eyeball member 1 could be made of any desired degree of opacity and of any suitable color. The upper half of the outer surface of the eyeball member 1 can be covered with a layer of material P and this preferably has a pink color, so as to simulate the eyelid.

The eyeball member 1 can have a lug 2 provided with a slot 3. This lug 2 may be integral with the eyeball member 1. If desired, the lug 2 may be made of metal and it can be suitably connected to the eyeball member 1. The portion of the eyeball member 1 which is diametrically opposite to the lug 2 is also provided with a cutout or recess 4, in order to permit the free rolling movement of the eye. The eyeball member 1 is also provided with openings 9 and 9a at the top and at the bottom thereof.

As shown in Figs. 1 and 4, the eyeball member is provided with a relatively deep depression 5 in the rear surface thereof. A cross-shaped member 7 is located in said depression 5 and said cross-shaped member 7 is held in position by means of pins 8 and 8a which pass through the openings 9 and 9a of the eyeball member 1. A shaft 6 passes through the recess 4 and the slot 3, so that the eyeball member and its member 7 can freely turn in unison with respect to the shaft 6. The pins 8 and 8a also serve to limit the up and down turning movement of the eyeball member 1.

As shown in Fig. 3, the front of the eyeball member 1 is provided with a recess 10 for receiving an insert which simulates the pupil and the iris.

As shown in Figs. 3 and 5, the wall 11 of the recess 10 is convex and said wall flares outwardly.

Referring to Fig. 7, a flexible disc 12 of celluloid or other suitable material has painted, imprinted, or otherwise impressed thereon the rep-

resentation 14 of the pupil and the representation 15 of the iris. These parts 14 and 15 can be depicted in any desired colors. The disc 16 which is shown in Fig. 6 is also made of flexible celluloid.

As shown in Fig. 8, the rear of said disc 16 can be provided with a cup-shaped depression. The parts 12 and 16 are assembled by means of suitable dies, in order to form the assembly shown in Fig. 8. The action of the dies causes the iris portion 14 to enter the cup-shaped depression provided in the rear of the member 16. The rear of the member 15 is covered with a layer 12a of white and opaque material which can be any suitable paint or the like.

Since the member 16 is colorless and transparent, the light is reflected from the front surface of the member 12. Since the member 12 is preferably transparent or translucent, the white opaque rear layer 12a reflects any light which passes through the member 12. The unitary insert which is thus formed has a peripheral wall 11a which is concave in longitudinal section so that it corresponds in shape to the wall 11 of the recess 10. Hence, when the insert is forced into the recess 10, a firm interlocking connection is secured. The insert therefore has a drive fit in the recess 10.

In the embodiment shown in Fig. 12, the representation 14 of the pupil is painted, printed, or otherwise impressed upon the front of the disc 12 and the representation of the iris member 15 is painted, printed, or otherwise impressed upon the rear of said disc.

This construction gives a more natural effect, because in the natural eye, the pupil protrudes in front of the iris. Likewise, the representation of the iris may be printed or otherwise formed, up to the edge of the pupil. If the pupil and iris are on the same side, there is danger of these representations overlapping.

Likewise, the disc 12 may be made of celluloid having powdered glass imbedded in its rear surface or front surface. The glass crystals may be connected to the celluloid disc by pressure, or by the use of a suitable transparent adhesive. Likewise, the glass crystals may be connected to the celluloid by the use of acetone or other material which softens celluloid. A celluloid cement can also be used and any suitable transparent adhesive lacquer may be employed. These fine crystals should be sufficiently separated from each other so as to break up the light and simulate the natural sparkle of the human eye. The member 16 is formed of flexible, transparent celluloid, as previously described, and the members 16 and 12 are assembled by means of suitable pressure. Of course it is well known to use heated dies in order to press or otherwise shape celluloid, and heat and pressure may be employed. Likewise, I do not wish to be limited to the use of celluloid, or to the use of material which must be molded by means of heat or pressure, and the method of working will depend upon the material selected.

In the embodiment shown in Fig. 11, an additional backing member 12b, which may be made of transparent and flexible celluloid, is utilized, and the white opaque layer 12a is formed upon the rear surface of the backing member 12b. Likewise, in this embodiment the peripheral wall of the insert is straight in longitudinal section, and the corresponding wall of the recess (shown in Fig. 10) is also straight in longitudinal section. In order to assemble the in-

sert shown in Fig. 10 with the eyeball member 1, a suitable adhesive can be employed. Likewise, the various parts of the insert can be connected by means of suitable adhesive which is preferably colorless and transparent. The use of such adhesive is necessary in utilizing some materials that cannot be readily formed under heat and pressure. For example, I do not wish to exclude the use of glass, although I prefer to use celluloid, since celluloid can be much more easily worked and it is not fragile.

As shown in Figs. 9 and 10, the outer surface of the insert has the same general contour as the outer surface of the eyeball member 1.

Referring to Figs. 8 and 10, it will be noted that the insert comprises a rigid composite member having a front member made of substantially transparent and colorless material. The rear member 12 has a projection which is located within and which interlocks with a depression which is provided in the rear surface of said front member. In addition, when the members 12 and 16 are joined by means of suitable heat and pressure, they are more or less welded together, in order to provide a very firm union. Since the completed insert is rigid, it can be forced under suitable pressure into the opening 10. The insert may have a certain amount of flexibility when it is completed, so that it can be readily forced into position, and then be retained in position due to its flexibility.

While I have shown a preferred method of making the improved article specified herein, the claims for the article of manufacture are not to be limited to the specific method disclosed herein.

I have shown a preferred embodiment of my invention, but it is clear that numerous changes and omissions can be made without departing from its spirit.

I claim:

1. An artificial eye comprising a light-permeable member having a body and a projection which extends forwardly from said body, the front of said projection having the representation of the pupil, the rear surface of said member having an annular representation of the iris around the rear of said projection.

2. An artificial eye comprising a light-permeable member made of non-vitreous material and having discrete light-refracting particles connected thereto, said member having the representation of the pupil and of the iris thereon.

3. An artificial eye comprising a light-permeable celluloid member having discrete light-refracting particles connected thereto, said member having the representation of the pupil and of the iris thereon.

4. An artificial eye comprising a light-permeable celluloid member having discrete light-refracting particles connected thereto, said member having the representation of the pupil and of the iris thereon, said member having a backing member of celluloid connected thereto, said light refracting particles being located at the adjacent surfaces of said members.

5. An artificial eye comprising an eyeball member having a recess which extends inwardly from the front wall of said eyeball member, said recess having a wall which is directly adjacent the front wall of the eyeball member, said wall of the recess having a convex shape in longitudinal section, and an insert made of bendable material and located in said recess, said insert simulating the pupil and the iris, said

80

35

90

95

100

105

110

115

120

125

130

135

140

145

150

insert having a wall which abuts said wall of said recess, said wall of the insert being concave in longitudinal section, the adjacent walls of said recess and of said insert closely abutting each other.

6. An artificial eye comprising an eyeball member having a recess which extends inwardly from the front wall of said eyeball member, said recess having a wall which is directly adjacent the front wall of the eyeball member, said wall of the recess having a convex shape in longitudinal section, and an insert made of bendable material and located in said recess, said insert simulating the pupil and the iris, said insert having a wall which abuts said wall of said recess, said wall of the insert being concave in longitudinal section, the adjacent walls of said recess and of said insert closely abutting each other, said insert having a drive fit in said recess.

7. An artificial eye including a composite member which simulates the pupil and the iris, said composite member comprising a front member and a rear member each of which is made of bendable and light-permeable material, said members being connected to each other, said front member having a recess in the rear surface thereof, the rear member having a projection which extends forwardly from its body which fits snugly in said recess, said projection simulating the pupil and the adjacent surrounding portion of said rear member simulating the iris.

8. An artificial eye including a composite member which simulates the pupil and the iris,

said composite member comprising a front member and a rear member each of which is made of bendable and light-permeable material, said members being connected to each other, said front member having a recess in the rear surface thereof, the rear member having a projection which extends forwardly from its body which fits snugly in said recess, said projection simulating the pupil and the adjacent surrounding portion of said rear member simulating the iris, said rear member having a white opaque layer located on the rear surface thereof.

9. An artificial eye including a composite member which simulates the pupil and the iris, said composite member comprising a front member and a rear member each of which is made of bendable and light-permeable material, said members being connected to each other, said front member having a recess in the rear surface thereof, the rear member having a projection which extends forwardly from its body which fits snugly in said recess, said projection simulating the pupil and the adjacent surrounding portion of said rear member simulating the iris, the front surface of the front member being of substantially uniform curvature.

10. An artificial eye comprising a light-permeable member having a projection, one side of said light-permeable member having the representation of the pupil formed on one side thereof at said projection, said member having the representation of the iris formed on the other side thereof.

JULIUS DUNNER.

5	80
10	85
15	90
20	95
25	100
30	105
35	110
40	115
45	120
50	125
55	130
60	135
65	140
70	145
75	150