

(19) World Intellectual Property Organization
International Bureau



(43) International Publication Date
29 April 2004 (29.04.2004)

PCT

(10) International Publication Number
WO 2004/036549 A1

(51) International Patent Classification⁷: **G10L 19/02**

(21) International Application Number:
PCT/IB2003/001660

(22) International Filing Date: 22 April 2003 (22.04.2003)

(25) Filing Language: English

(26) Publication Language: English

(30) Priority Data:
02079303.0 14 October 2002 (14.10.2002) EP

(71) Applicant (for all designated States except US): **KONINKLIJKE PHILIPS ELECTRONICS N.V.** [NL/NL]; Groenewoudseweg 1, NL-5621 BA Eindhoven (NL).

(72) Inventors; and

(75) Inventors/Applicants (for US only): **BREEBAART, Dirk, J.** [NL/NL]; c/o Prof. Holstlaan 6, NL-5656 AA Eindhoven (NL). **SCHUIJERS, Erik, G., P.** [NL/NL]; c/o Prof. Holstlaan 6, NL-5656 AA Eindhoven (NL).

(74) Agent: **GROENENDAAL, Antonius, W., M.**; Philips Intellectual Property & Standards, Prof. Holstlaan 6, NL-5656 AA Eindhoven (NL).

(81) Designated States (national): AE, AG, AL, AM, AT, AU, AZ, BA, BB, BG, BR, BY, BZ, CA, CH, CN, CO, CR, CU, CZ, DE, DK, DM, DZ, EC, EE, ES, FI, GB, GD, GE, GH, GM, HR, HU, ID, IL, IN, IS, JP, KE, KG, KP, KR, KZ, LC, LK, LR, LS, LT, LU, LV, MA, MD, MG, MK, MN, MW, MX, MZ, NI, NO, NZ, OM, PH, PL, PT, RO, RU, SC, SD, SE, SG, SK, SL, TJ, TM, TN, TR, TT, TZ, UA, UG, US, UZ, VC, VN, YU, ZA, ZM, ZW.

(84) Designated States (regional): ARIPO patent (GH, GM, KE, LS, MW, MZ, SD, SL, SZ, TZ, UG, ZM, ZW), Eurasian patent (AM, AZ, BY, KG, KZ, MD, RU, TJ, TM), European patent (AT, BE, BG, CH, CY, CZ, DE, DK, EE, ES, FI, FR, GB, GR, HU, IE, IT, LU, MC, NL, PT, RO, SE, SI, SK, TR), OAPI patent (BF, BJ, CF, CG, CI, CM, GA, GN, GQ, GW, ML, MR, NE, SN, TD, TG).

Published:
— with international search report

For two-letter codes and other abbreviations, refer to the "Guidance Notes on Codes and Abbreviations" appearing at the beginning of each regular issue of the PCT Gazette.

(54) Title: SIGNAL FILTERING

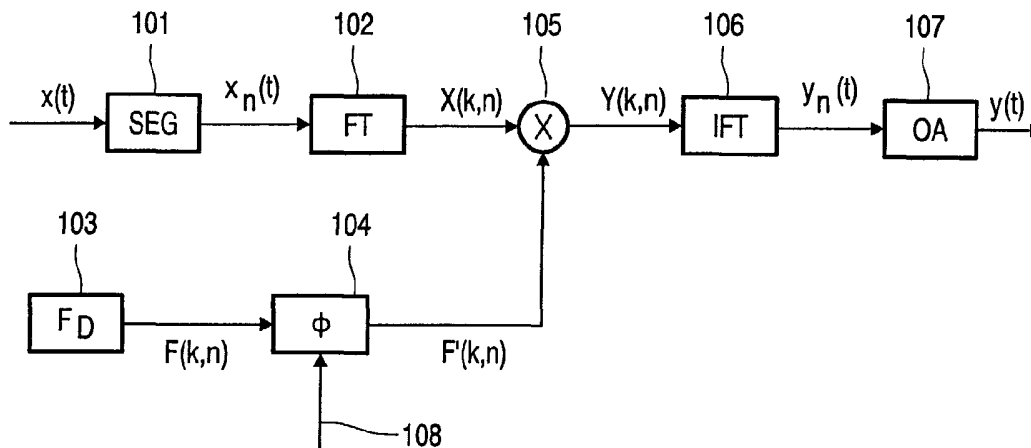

(57) Abstract: A method of filtering an information signal ($x(t)$), the method comprising modifying frequency domain components ($X(k,n)$) of the information signal according to a desired filter response ($F(k,n)$); wherein the step of modifying frequency domain components further comprises modifying (105) frequency domain components of a first frame of said information signal according to a first actual filter response ($F'(k,n)$), the first actual filter response being a function (Φ) of the desired filter response and information (108) related to a previous frame of the information signal.

WO 2004/036549 A1

Signal filtering

This invention relates to the filtering of an information signal and, in particular, to the filtering of an information signal by modifying frequency domain components of the information signal according to a desired filter response.

5

In the field of signal processing, it is known to perform a filtering of an information signal, such as an audio signal, by segmenting the information signal using overlapping frames, transforming the frames into the frequency domain, modifying the frequency-domain components of the signal frame, inverse transforming the modified frequency-domain components back into the time domain, and performing an overlap-add operation (see e.g. Oppenheim & Shafer: "Discrete-time signal processing", Prentice Hall signal processing series, 1989).

The above prior art involves the problem that the overlap-add operation of successive frames may result in undesirable artifacts, if the filtering step, i.e. the modification of the frequency-domain components, includes a processing with dynamically varying parameters, in particular with a varying phase. For example, it may happen that a certain frequency component adds in-phase for the overlap of two consecutive frames n and $n+1$, while the same components may be out-of-phase, if frame $n+1$ is compared to $n+2$. In the case of audio signals, these artifacts may result in unstable sound quality, e.g. modulations. In general, such artifacts may occur for any block-based implementation, i.e. an implementation where a filter transform is updated at a rate lower than the sample rate of the signal, thereby generating artifacts due to block-varying phases.

The above and other problems are solved by a method of filtering an information signal, the method comprising modifying frequency domain components of the information signal according to a desired filter response; wherein the step of modifying frequency domain components further comprises modifying frequency domain components of a first frame of said information signal according to a first actual filter response, the first actual filter response being a function of the desired filter response and information related to a previous frame of the information signal.

Hence, by modifying the frequency domain components of a current signal frame according to an actual filter response which is a function of the desired filter response and information related to a previous frame of the information signal, the filter response of a processing step is transformed taking a previous processing step into consideration.

5 Consequently, artifacts due to phase changes across consecutive frames are efficiently reduced.

In general, the processing of a filter may be described by its filter response. In the frequency domain, the filter output for a given frequency component may be expressed as a corresponding input frequency component multiplied with a, in general complex, filter response or weight factor. The term desired filter response comprises the filter response or weight factors corresponding to the desired filter function. Methods for determining desired filter responses for a given filter are known in the art of signal processing (see e.g. Oppenheim & Shafer, "Discrete-time signal processing", Prentice Hall signal processing series, 1989). The term actual filter response comprises the filter response actually applied to the input signal according to the invention.

In a preferred embodiment of the invention, the method further comprises

- segmenting an information signal into a number of signal frames;
- transforming the signal frames to obtain frequency domain components of the respective signal frames;
- 20 - inverse transforming the modified frequency domain components to obtain filtered signal frames; and
- performing a recombination operation of the filtered signal frames to obtain a filtered information signal.

Hence, an efficient filtering method is provided which reduces the amount of distortions introduced due to the filtering.

Preferably, the function of the desired filter response and information related to a previous frame is selected as to reduce artifacts introduced by the step of performing a recombination operation, thereby improving the perceptual quality of the information signal.

Here, the term recombination operation comprises any recombination technique for recombining the modified signal from the modified signal frames. Examples of such recombination operations comprise an overlap-add method, an overlap-save method, or the like.

The information related to a previous frame may comprise a filter response of a previous frame, the modified frequency components of a previous frame, or the like.

In a preferred embodiment, the information related to a previous frame comprises at least one of the actual filter response and the desired filter response of a previous frame of the information signal. Hence the actual filter response may be a function of the desired filter response of one or more previous frames and/or the actual filter response applied to one or more previous frames, thereby providing a method which may be adapted to a large variety of applications.

It is noted that the function may further depend on additional information, such as information about the current frame, e.g. a tonality measure of the current frame.

In another preferred embodiment, the step of modifying frequency domain components of a first frame further comprises

- determining a desired filter response for the first frame;
- determining the first actual filter response for the first frame as a function of the desired filter response and at least a second filter response related to a previous frame of the information signal; and
- applying the determined actual first filter response to the first frame to obtain modified frequency domain components of the first frame.

It is further preferred that the function of the desired filter response and the second filter response is selected as to reduce phase changes of the filter response.

In a further preferred embodiment, the step of determining the first actual filter response comprises

- determining a phase difference of a frequency component of the desired filter response for the first frame and a corresponding frequency component of the filter response of a previous frame;
- determining a desired phase change as a function of the determined phase difference; and
- determining a frequency component of the first actual filter response as the corresponding frequency component of the filter response of a previous frame modified by a phase change factor comprising the determined desired phase change.

Hence, a method is provided for efficiently limiting the phase change of the filter response between consecutive frames, thereby reducing perceptible artifacts in the resulting signal.

In a yet further preferred embodiment, the function of the determined phase difference is a cut-off function limiting the phase difference to be smaller than a predetermined threshold value. Hence a determination of the phase difference is provided that only requires little computational resources. Furthermore, as the threshold value may be

selected according to the actual application, e.g. as a fixed value, a time and/or frequency dependant value, or the like, the method may be adapted to a variety of applications.

Alternatively, other relations between the determined and the desired phase difference may be chosen, e.g. a soft-knee behavior provided by a saturated input-output function.

5 In a yet further preferred embodiment, said reduction of phase changes of the filter response is made dependant on a measure of tonality. For example, for a noise-like signal, phase jumps between consecutive samples may occur in the input signal. Limiting the phase difference for such samples may change the perceptual properties of the filtered signal in an undesired way. For example, in the case of audio signals, a noise-like signal would
10 become more tonal which is often perceived as a synthetic or metallic sound. Hence by only - or at least predominantly - limiting the phase difference of signal frames having a high level of tonality, the above undesired effects may be reduced.

 The present invention can be implemented in different ways including the method described above and in the following, an arrangement, and further product means,
15 each yielding one or more of the benefits and advantages described in connection with the first-mentioned method, and each having one or more preferred embodiments corresponding to the preferred embodiments described in connection with the first-mentioned method and disclosed in the dependant claims.

 It is noted that the features of the method described above and in the following
20 may be implemented in software and carried out in a data processing system or other processing means caused by the execution of computer-executable instructions. The instructions may be program code means loaded in a memory, such as a RAM, from a storage medium or from another computer via a computer network. Alternatively, the described features may be implemented by hardwired circuitry instead of software or in combination
25 with software.

 The invention further relates to an arrangement for filtering an information signal, the arrangement comprising means for modifying frequency domain components of the information signal according to a desired filter response; wherein the means for modifying frequency domain components of the information signal comprises means for
30 modifying frequency domain components of a first frame of said information signal according to a first actual filter response, the first actual filter response being a function of the desired filter response and information related to a previous frame of the information signal.

It is noted that the above arrangement including the means for modifying the frequency components may be implemented as general- or special-purpose programmable microprocessors, Digital Signal Processors (DSP), Application Specific Integrated Circuits (ASIC), Programmable Logic Arrays (PLA), Field Programmable Gate Arrays (FPGA),
5 special purpose electronic circuits, etc., or a combination thereof.

The invention further relates to an electronic device comprising such an arrangement. The term electronic device comprises any device suitable for the processing of an information signal. Examples of such devices comprise audio equipment including an audio decoder for decoding coded audio information, such as audio players, recorders, etc.

10 The invention further relates to a filtered information signal generated by the method described above and in the following. The filtered information signal may further be processed, e.g. coded according to a known coding scheme, such as an MPEG coding scheme.

The invention further relates to a storage medium having stored thereon such a
15 filtered information signal.

Here, the term storage medium comprises but is not limited to a magnetic tape, an optical disc, a digital video disk (DVD), a compact disc (CD or CD-ROM), a mini-disc, a hard disk, a floppy disk, a ferro-electric memory, an electrically erasable programmable read only memory (EEPROM), a flash memory, an EPROM, a read only memory (ROM), a static
20 random access memory (SRAM), a dynamic random access memory (DRAM), a synchronous dynamic random access memory (SDRAM), a ferromagnetic memory, optical storage, charge coupled devices, smart cards, a PCMCIA card, etc.

25 These and other aspects of the invention will be apparent and elucidated from the embodiments described in the following with reference to the drawing in which:

fig. 1 illustrates a method of filtering an information signal according to an embodiment of the invention;

fig. 2 illustrates an embodiment of the transformation of the filter response;

30 fig. 3 illustrates examples of functional forms used in the embodiment of fig. 2; and

fig. 4 illustrates another embodiment of the transformation of the filter response.

Fig. 1 illustrates a method of filtering an information signal according to an embodiment of the invention. In an initial step 101, an incoming information signal $x(t)$ is segmented into a number of frames. The incoming signal is assumed to be a suitably sampled waveform, e.g. representing an audio signal or the like. For example, in the case of an audio signal, t represents a discrete time. Therefore, we will refer to signals indexed by t as signals in the time domain. However, it is understood that, for other types of information signals, t may represent other coordinates, such as spatial coordinates. The segmentation step 101 splits the signal into frames $x_n(t)$ of a suitable length, for example in the range 500-5000 samples, e.g. 1024 or 2048 samples. Preferably, the segmentation is performed using overlapping window functions, thereby suppressing artefacts which may be introduced at the frame boundaries (see e.g. Princen, J. P., and Bradley, A. B.: "Analysis/synthesis filterbank design based on time domain aliasing cancellation", IEEE transactions on Acoustics, Speech and Signal processing, Vol. ASSP 34, 1986).

In step 102, each of the frames $x_n(t)$ is transformed into the frequency domain by applying a Fourier transformation, preferably implemented as a Fast Fourier Transform (FFT). The resulting frequency representation of the n -th frame $x_n(t)$ comprises a number of frequency components $X(k,n)$ where the parameter n indicates the frame number and the parameter k indicates the frequency component or frequency bin corresponding to a frequency ω_k , $0 < k < K$. In general, the frequency domain components $X(k,n)$ are complex numbers.

In step 103, the desired filter for the current frame is determined. In many applications the calculation of the desired filter is performed adaptively, i.e. in response to predetermined properties of the incoming signal, or controlled by time-varying parameters, i.e. in response to other signals or parameters, or the like. For example, in the field of parametric audio coding a stereo signal is often synthesized from a coded mono signal and predetermined additional parameters, such as a correlation between the left and right channels, etc. During synthesis of the stereo signal, each channel is filtered according to the desired properties of the resulting stereo signal. In another example, received communications signals are often filtered according to estimated channel properties.

The desired filter is expressed as a desired filter response comprising a set of K complex weight factors $F(k,n)$, $0 < k < K$, for the n -th frame. The filter response $F(k,n)$ may be represented by two real numbers, i.e. its amplitude $a(k,n)$ and its phase $\phi(k,n)$ according to

$$F(k,n) = a(k,n) \cdot \exp[j \varphi(k,n)].$$

In the frequency domain, the filtered frequency components are $Y(k,n) = F(k,n) \cdot X(k,n)$, i.e. they result from a multiplication of the frequency components $X(k,n)$ of the input signal with the filter response $F(k,n)$. As will be apparent to a skilled person, this multiplication in the frequency domain corresponds to a convolution of the input signal frame $x_n(t)$ with a corresponding filter $f_n(t)$.

According to the invention, in step 104, the desired filter response $F(k,n)$ is modified before applying it to the current frame $X(k,n)$. In particular, the actual filter response $F'(k,n)$ to be applied is determined as a function of the desired filter response $F(k,n)$ and of information 108 about previous frames. Preferably, this information comprises the actual and/or desired filter response of one or more previous frames, according to

$$\begin{aligned} F'(k,n) &= a'(k,n) \cdot \exp[j \varphi'(k,n)] \\ &= \Phi[F(k,n), F(k,n-1), F(k,n-2), \dots, F'(k,n-1), F'(k,n-2), \dots]. \end{aligned}$$

Hence, by making the actual filter response dependant of the history of previous filter responses, artifacts introduced by changes in the filter response between consecutive frames may be efficiently suppressed. Preferably, the actual form of the transform function Φ is selected to reduce overlap-add artifacts resulting from dynamically-varying filter responses.

For example, the transform function Φ may be a function of a single previous response function, e.g. $F'(k,n) = \Phi_1[F(k,n), F(k,n-1)]$ or $F'(k,n) = \Phi_2[F(k,n), F'(k,n-1)]$. In another embodiment, the transform function may comprise a floating average over a number of previous response functions, e.g. a filtered version of previous response functions, or the like. Preferred embodiments of the transform function Φ will be described in greater detail below.

In step 105, the actual filter response $F'(k,n)$ is applied to the current frame by multiplying the frequency components $X(k,n)$ of the current frame of the input signal with the corresponding filter response factors $F'(k,n)$ according to

$$Y(k,n) = F'(k,n) \cdot X(k,n).$$

In step 106, the resulting processed frequency components $Y(k,n)$ are transformed back into the time domain resulting in filtered frames $y_n(t)$. Preferably, the inverse transform is implemented as an Inverse Fast Fourier Transform (IFFT).

Finally, in step 107, the filtered frames are recombined to a filtered signal $y(t)$ by an overlap-add method. An efficient implementation of such an overlap add method is disclosed in Bergmans, J. W. M.: "Digital baseband transmission and recording", Kluwer, 1996.

Fig. 2 illustrates an embodiment of the transformation of the filter response. According to this embodiment, the transform function Φ of step 104 in fig. 1 is implemented as a phase-change limiter between the current and the previous frame.

In step 201, the phase change $\delta(k)$ of each frequency component $F(k,n)$ compared to the actual phase modification $\varphi'(k,n-1)$ applied to the previous sample of the corresponding frequency component is computed, i.e.

$$\delta(k) = \varphi(k,n) - \varphi'(k,n-1).$$

In step 202, the phase component of the desired filter $F(k,n)$ is modified in such a way that the phase change across frames is reduced, if the change would result in overlap-add artifacts. According to this embodiment, this is achieved by ensuring that the actual phase difference does not exceed a predetermined threshold c , e.g. by simply cutting of the phase difference, according to

$$(k, n) = \begin{cases} F(k, n) & \text{if } |\delta(k)| < c \\ F'(k, n-1).e^{j.c.\text{sign}[\delta(k)]} & \text{otherwise} \end{cases} \quad (1)$$

The threshold value c may be a predetermined constant, e.g. between $\pi/8$ and $\pi/3$ rad. In one embodiment, the threshold c may not be a constant but e.g. a function of time, frequency, and/or the like. Furthermore, alternatively to the above hard limit for the phase change, other phase-change-limiting functions may be used.

Fig. 3 illustrates examples of functional forms used in the embodiment of fig. 2. In general, in the above embodiment, the desired phase-change across subsequent time frames for individual frequency components is transformed by an input-output function $P(\delta(k))$ and the actual filter response $F'(k,n)$ is given by

$$F'(k,n) = F'(k,n-1) \cdot \exp[j P(\delta(k))]. \quad (2)$$

Hence, according to this embodiment, a transform function P of the phase
 5 change across subsequent time frames is introduced.

Fig. 3 illustrates two examples of functional forms of the transform function P .
 The solid curve illustrates the hard limit described above, which limits the phase change to be
 smaller than the threshold c , as illustrated by the dotted lines 303. As an alternative to the
 above "hard-knee" input-output relation, a "soft-knee" input-output relation may be used as
 10 illustrated by the dashed line 302 in fig. 3. Such a smooth transition may be implemented by
 a differentiable, monotonous function, e.g. $P(x) = c \tanh(\alpha x)$, where c is the above threshold
 and the parameter α determines the slope of the curve.

Again referring to fig. 2, in step 203, the actual filter response $F'(k,n)$ is
 determined according to eqn. (2) above.

15 Fig. 4 illustrates another embodiment of the transformation of the filter
 response. According to this embodiment, the phase limiting procedure is driven by a suitable
 measure of tonality, e.g. a prediction method as described below. This has the advantage that
 phase jumps between consecutive frames which occur in noise-like signals may be excluded
 from the phase-change limiting procedure according to the invention. This is an advantage,
 20 since limiting such phase jumps in noise like signals would make the noise-like signal sound
 more tonal which is often perceived as synthetic or metallic.

According to the embodiment of fig. 4, in step 401, a predicted phase error

$$\theta(k) = \varphi(k,n) - \varphi(k,n-1) - \omega_k \cdot h$$

25

is calculated. Here, ω_k denotes the frequency corresponding to the k -th frequency component
 and h denotes the hop size in samples. Here, the term hop size refers to the difference
 between two adjacent window centers, i.e. half the analysis length for symmetric windows. In
 the following, it is assumed that the above error is wrapped to the interval $[-\pi, +\pi]$.

30

In step 402, a prediction measure P_k for the amount of phase predictability in
 the k -th frequency bin is calculated according to

$$P_k = (\pi - |\theta(k)|) / \pi \in [0,1],$$

where $|\cdot|$ denotes the absolute value.

Hence, the above measure P_k yields a value between 0 and 1 corresponding to the amount of phase-predictability in the k -th frequency bin. If P_k is close to 1, the underlying signal may be assumed to have a high degree of tonality, i.e. has a substantially sinusoidal waveform. For such a signal, phase jumps are easily perceivable, e.g. by the listener of an audio signal. Hence, phase jumps should preferably be removed in this case. On the other hand, if the value of P_k is close to 0, the underlying signal may be assumed to be noisy. For noisy signals phase jumps are not easily perceived and may, therefore, be allowed.

Accordingly, in step 403, the phase limiting function is applied if P_k exceeds a predetermined threshold, i.e. $P_k > A$, resulting in the actual filter response $F'(k,n)$. For example, a phase limiting function as described in connection with figs. 2 and 3 may be applied if $P_k > A$, according to

$$F'(k, n) = \begin{cases} F(k, n), & \text{if } P_k < A \\ F'(k, n-1) \cdot e^{j \cdot P[\delta(k)]}, & \text{otherwise} \end{cases}$$

Here, A is limited by the upper and lower boundaries of P which are +1 and 0, respectively. The exact value of A depends on the actual implementation. For example, A may be selected between 0.6 and 0.9.

It is understood that, alternatively, any other suitable measure for estimating the tonality may be used. In yet another embodiment, the allowed phase jump c described above may be made dependant on a suitable measure of tonality, e.g. the measure P_k above, thereby allowing for larger phase jumps if P_k is large and vice versa.

It is noted that the above methods may be implemented by corresponding arrangements, e.g. implemented as general- or special-purpose programmable microprocessors, Digital Signal Processors (DSP), Application Specific Integrated Circuits (ASIC), Programmable Logic Arrays (PLA), Field Programmable Gate Arrays (FPGA), special purpose electronic circuits, etc., or a combination thereof. Hence, figs. 1, 2, and 4 above may be read as block diagrams of such arrangements.

It should further be noted that the above-mentioned embodiments illustrate rather than limit the invention, and that those skilled in the art will be able to design many alternative embodiments without departing from the scope of the appended claims.

It should further be noted that even though the invention has primarily been described in connection with an audio signal, the scope of the invention is not restricted to

audio signals. It is understood that the invention may also be applied to other information signals, such as multimedia signals, video signals, animations, graphics, still images, or the like.

5 The method according to the invention may be applied to the filtering of a large variety of information signals. As an example, the method may be applied in the field of parametric stereo coding. As is known in the field of parametric stereo coding, in a decoder of such a coding system, two output signals are synthesized, both having time-varying phase modifications. Using the method according to the present invention, the inventors have observed a considerable improvement of the quality of the synthesized output signals of such
10 a system.

In the claims, any reference signs placed between parentheses shall not be construed as limiting the claim. The word "comprising" does not exclude the presence of elements or steps other than those listed in a claim. The word "a" or "an" preceding an element does not exclude the presence of a plurality of such elements.

15 The invention can be implemented by means of hardware comprising several distinct elements, and by means of a suitably programmed computer. In the device claim enumerating several means, several of these means can be embodied by one and the same item of hardware. The mere fact that certain measures are recited in mutually different dependent claims does not indicate that a combination of these measures cannot be used to
20 advantage.

CLAIMS:

1. A method of filtering an information signal, the method comprising modifying frequency domain components of the information signal according to a desired filter response; wherein the step of modifying frequency domain components further comprises modifying frequency domain components of a first frame of said information signal
5 according to a first actual filter response, the first actual filter response being a function of the desired filter response and information; related to a previous frame of the information signal.
2. A method according to claim 1, wherein the method further comprises
10 - segmenting an information signal into a number of signal frames;
- transforming the signal frames to obtain frequency domain components of the respective signal frames;
- inverse transforming the modified frequency domain components to obtain filtered signal frames; and
15 - performing a recombination operation of the filtered signal frames to obtain a filtered information signal.
3. A method according to claim 2, wherein the function of the desired filter response and information related to a previous frame is selected as to reduce artifacts
20 introduced by the step of performing a recombination operation.
4. A method according to claim 2, wherein the recombination operation comprises an overlap-add operation.
- 25 5. A method according to claim 1, wherein the information related to a previous frame is comprises at least one of the actual filter response and the desired filter response of a previous frame of the information signal.

6. A method according to claim 1, wherein the step of modifying frequency domain components of a first frame further comprises
- determining a desired filter response for the first frame;
 - determining the first actual filter response for the first frame as a function of the desired filter response and at least a second filter response related to a previous frame of the information signal; and
 - applying the determined actual first filter response to the first frame to obtain modified frequency domain components of the first frame.
7. A method according to claim 6, wherein the step of determining the first actual filter response comprises
- determining a phase difference of a frequency component of the desired filter response for the first frame and a corresponding frequency component of the filter response of a previous frame;
 - determining a desired phase change as a function of the determined phase difference; and
 - determining a frequency component of the first actual filter response as the corresponding frequency component of the filter response of a previous frame modified by a phase change factor comprising the determined desired phase change.
8. A method according to claim 7, wherein the function of the determined phase difference is a cut-off function limiting the phase difference to be smaller than a predetermined threshold value.
9. A method according to claim 6, wherein the function of the desired filter response and information related to a previous frame is selected to reduce phase changes of the filter response.
10. A method according to claim 9, wherein said reduction of phase changes of the filter response is made dependant on a measure of tonality.
11. A method according to claim 1, wherein the information signal is an audio signal.

12. An arrangement for filtering an information signal, the arrangement comprising means for modifying frequency domain components of the information signal according to a desired filter response; wherein the means for modifying frequency domain components of the information signal comprises means for modifying frequency domain
5 components of a first frame of said information signal according to a first actual filter response, the first actual filter response being a function of the desired filter response and information related to a previous frame of the information signal.

13. An electronic device comprising an arrangement for filtering an information
10 signal, the arrangement comprising means for modifying frequency domain components of the information signal according to a desired filter response; wherein the means for modifying frequency domain components of the information signal comprises means for modifying frequency domain components of a first frame of said information signal according to a first actual filter response, the first actual filter response being a function of
15 the desired filter response and information related to a previous frame of the information signal.

14. A filtered information signal generated by a method of filtering an information
20 signal, the method comprising modifying frequency domain components of the information signal according to a desired filter response; wherein the step of modifying frequency domain components further comprises modifying frequency domain components of a first frame of said information signal according to a first actual filter response, the first actual filter response being a function of the desired filter response and information related to a previous
25 frame of the information signal.

15. A storage medium having stored thereon a information signal according to
claim 14.

1/2

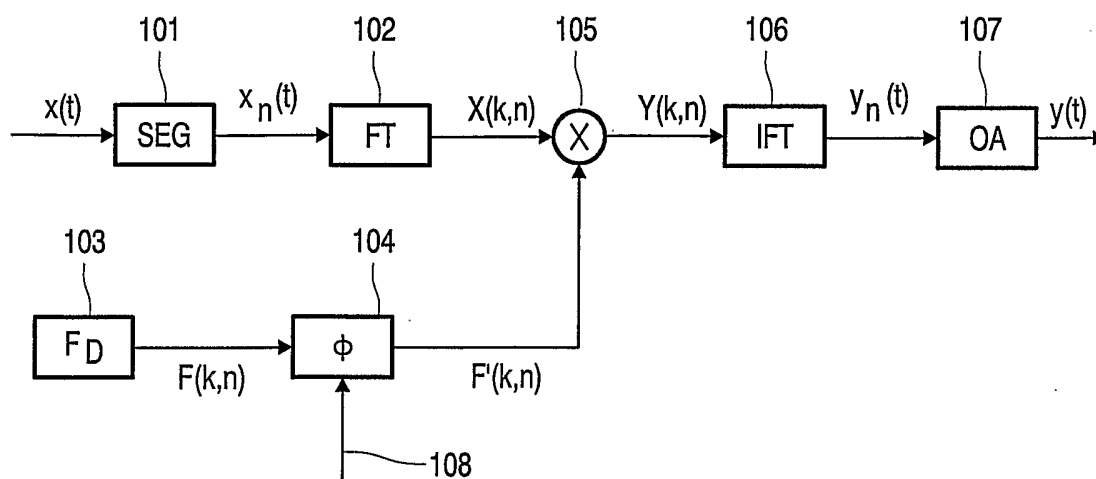

FIG. 1

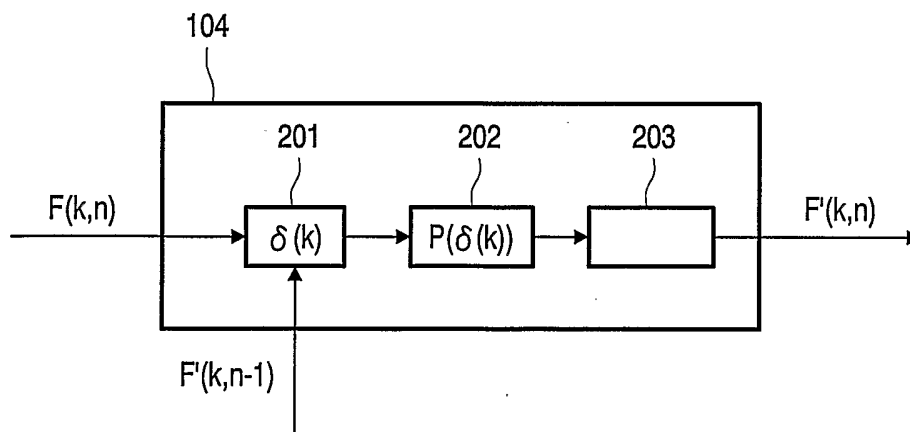

FIG. 2

2/2

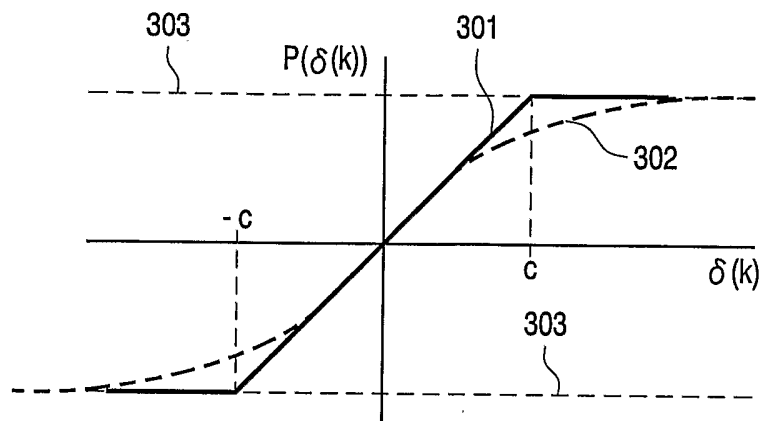

FIG. 3

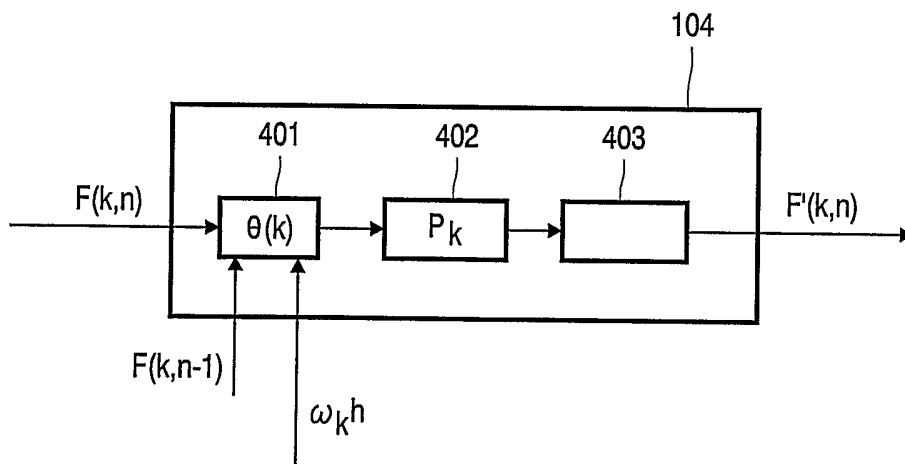

FIG. 4

INTERNATIONAL SEARCH REPORT

Internat'l Application No
PCT/TB 03/01660

A. CLASSIFICATION OF SUBJECT MATTER
IPC 7 G10L19/02

According to International Patent Classification (IPC) or to both national classification and IPC

B. FIELDS SEARCHED

Minimum documentation searched (classification system followed by classification symbols)
IPC 7 G10L G06F H04N H04S

Documentation searched other than minimum documentation to the extent that such documents are included in the fields searched

Electronic data base consulted during the international search (name of data base and, where practical, search terms used)

EPO-Internal, WPI Data, PAJ, INSPEC

C. DOCUMENTS CONSIDERED TO BE RELEVANT

Category °	Citation of document, with indication, where appropriate, of the relevant passages	Relevant to claim No.
A	US 6 112 169 A (DOLSON MARK) 29 August 2000 (2000-08-29) abstract	1-15
A	WO 89 09985 A (MASSACHUSETTS INST TECHNOLOGY) 19 October 1989 (1989-10-19) abstract	1-15
A	EP 0 538 877 A (MICOM COMMUNICATIONS CORP) 28 April 1993 (1993-04-28) abstract	1-15
A	US 5 475 629 A (TAKAHASHI SUSUMU) 12 December 1995 (1995-12-12) abstract	1-15
	-/--	

Further documents are listed in the continuation of box C.

Patent family members are listed in annex.

° Special categories of cited documents :

- "A" document defining the general state of the art which is not considered to be of particular relevance
- "E" earlier document but published on or after the international filing date
- "L" document which may throw doubts on priority claim(s) or which is cited to establish the publication date of another citation or other special reason (as specified)
- "O" document referring to an oral disclosure, use, exhibition or other means
- "P" document published prior to the international filing date but later than the priority date claimed

- "T" later document published after the international filing date or priority date and not in conflict with the application but cited to understand the principle or theory underlying the invention
- "X" document of particular relevance; the claimed invention cannot be considered novel or cannot be considered to involve an inventive step when the document is taken alone
- "Y" document of particular relevance; the claimed invention cannot be considered to involve an inventive step when the document is combined with one or more other such documents, such combination being obvious to a person skilled in the art.
- "&" document member of the same patent family

Date of the actual completion of the international search

26 June 2003

Date of mailing of the international search report

11.07.2003

Name and mailing address of the ISA

European Patent Office, P.B. 5818 Patentlaan 2
NL - 2280 HV Rijswijk
Tel. (+31-70) 340-2040, Tx. 31 651 epo nl,
Fax: (+31-70) 340-3016

Authorized officer

MARKUS STÄLÖ/JA A

INTERNATIONAL SEARCH REPORT

Intern: Application No

PCT/TB 03/01660

C.(Continuation) DOCUMENTS CONSIDERED TO BE RELEVANT

Category °	Citation of document, with indication, where appropriate, of the relevant passages	Relevant to claim No.
A	US 2001/023396 A1 (CUPERMAN VLADIMIR ET AL) 20 September 2001 (2001-09-20) abstract	1-15

INTERNATIONAL SEARCH REPORT

Intern: Application No

PCT/TB 03/01660

Patent document cited in search report		Publication date	Patent family member(s)	Publication date
US 6112169	A	29-08-2000	EP 1008138 A1 WO 9820481 A1	14-06-2000 14-05-1998
WO 8909985	A	19-10-1989	US 4937873 A AU 3736289 A CA 1337665 C WO 8909985 A1	26-06-1990 03-11-1989 28-11-1995 19-10-1989
EP 0538877	A	28-04-1993	US 5189701 A DE 69232904 D1 DE 69232904 T2 EP 0538877 A2	23-02-1993 27-02-2003 18-06-2003 28-04-1993
US 5475629	A	12-12-1995	JP 3310682 B2 JP 5216482 A EP 0552927 A2 US 5392231 A	05-08-2002 27-08-1993 28-07-1993 21-02-1995
US 2001023396	A1	20-09-2001	US 6233550 B1 WO 9910719 A1	15-05-2001 04-03-1999