

May 31, 1966

D. S. CHISHOLM

3,253,473

MECHANICAL LINKAGE

Filed Sept. 2, 1964

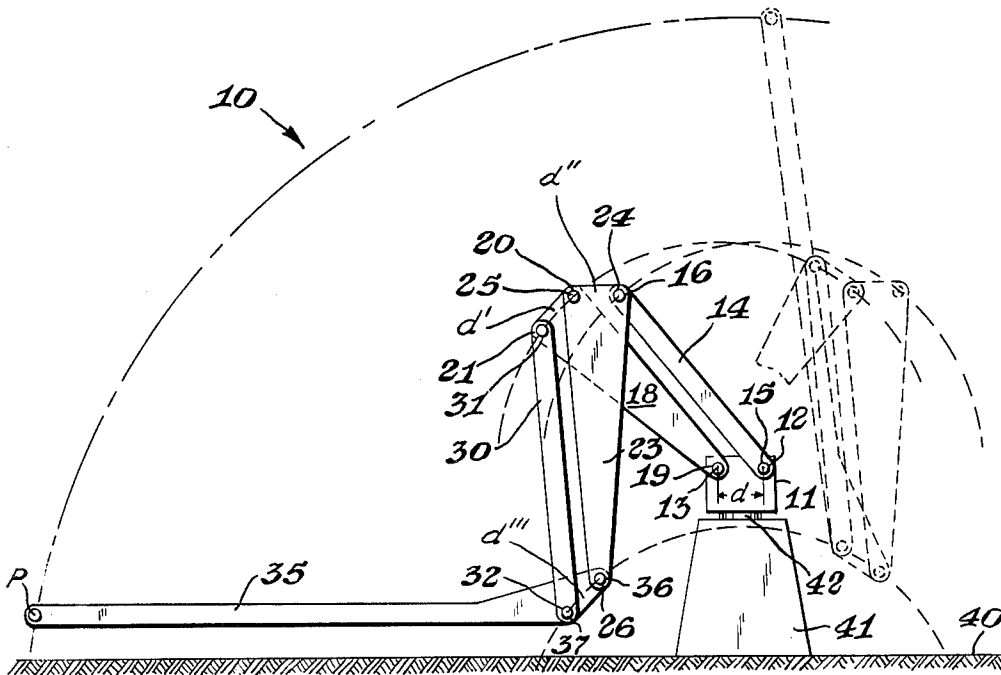

Fig. 1

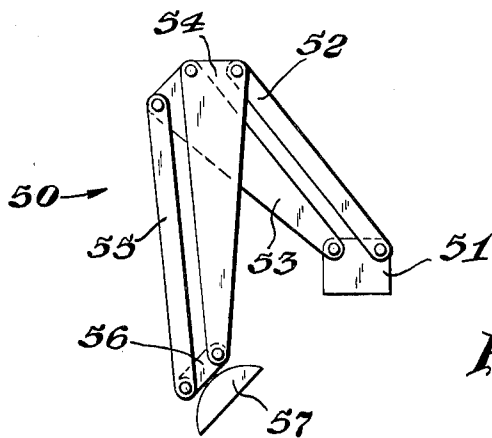

Fig. 2

INVENTOR
Douglas S. Chisholm
BY *Robert H. Graham*
AGENT
Jerome Rudix
ATTORNEY

3,253,473

MECHANICAL LINKAGE

Douglas S. Chisholm, Midland, Mich., assignor to The Dow Chemical Company, Midland, Mich., a corporation of Delaware

Filed Sept. 2, 1964, Ser. No. 394,025
7 Claims. (Cl. 74-96)

This invention relates to an improved mechanical linkage and in particular relates to a linkage which is capable of tracing circular and non-circular curves and spherical and non-spherical surfaces.

Oftentimes in the construction of buildings of a dome-like configuration, it is desired to provide surfaces or arcs which have a center that is not readily accessible. This is particularly true in the construction of buildings having spherical surfaces. By the term "spherical surface" is meant the surface or portion of a surface or a polygonal surface having a sufficient number of faces that it approximates a sphere. Oftentimes it is necessary to employ jigs, templates and the like where a center of generation is not readily available. In certain instances, it is also desirable to rotate a body such as, for example, a radar antenna or a source of high energy ionizing radiation, for example, in a radiation treatment of a specific location external to the treating apparatus.

An object of this invention is to provide a mechanical linkage for the generation of arcs.

A further object of this invention is to provide an improved mechanical linkage for the generation of curved surfaces.

Another object of this invention is to provide a mechanical linkage for the generation of circular and spherical segments without need for access to the center of such arc or segment.

These benefits and other advantages in accordance with the present invention are achieved in a mechanical linkage having 6 arms, 7 pivot points and two 4-bar linkages, which comprise in cooperative combination a base arm having a first pivot and a second pivot, the first and second pivots of the base arm being separated by a distance d , a first linkage arm having a first pivot and a second pivot, the first pivot of the first linkage arm being connected to the first pivot of the base arm, a first linkage second arm having a first pivot, a second pivot and a third pivot, the first pivot of the first linkage second arm being operatively connected to the second pivot of the base arm, a second linkage first arm having a first pivot, a second pivot and a third pivot, the first pivot of the second linkage first arm being in cooperative connection with the second pivot of the first linkage first arm, the second pivot of the second linkage first arm being in cooperative combination with the second pivot of the first linkage second arm, the first linkage second arm having the second and third pivots disposed about equally distant from the first pivot, the second linkage first arm having the first and second pivots disposed about equally distant from the third pivot, a second linkage second arm having a first and second pivot, the first pivot of the second linkage second arm being pivotally attached to the third pivot of the first linkage second arm, a second linkage third arm having first and second pivots, the first pivot of the second linkage third arm being pivotally attached to the third pivot of the second linkage first arm and the second pivot of the second linkage third arm being pivotally attached to the second pivot of the second linkage second arm, all of the foregoing arm pivots pivoting about parallel axes.

Further benefits, features and advantages of the present invention will become more apparent from the following specification when taken in connection with the drawings wherein:

FIGURE 1 is a schematic representation of the basic

linkage configuration of the present invention employing a swiveling base arm.

FIGURE 2 is a schematic representation of a radiation source mounted upon a linkage in accordance with the invention.

In FIGURE 1 there is a schematic representation of a linkage in accordance with the invention generally designated by the representative numeral 10. The apparatus 10 comprises in cooperative combination a base arm 11 having a first pivot or point 12 and a second pivot 13. The pivots 12 and 13 are separated by a distance designated as d . A first linkage first arm 14, having a first pivot 15 and a second pivot 16, is operatively connected to the first pivot 12 of the base arm 11 by the first pivot 15 of the arm 14. A first linkage second arm 18 has a first pivot 19, a second pivot 20 and a third pivot 21, the pivots 20 and 21 are separated by a distance d' and are equally distant from the pivot 19. The pivot 19 is operatively connected to the pivot 13 of the base arm 11. The distance between the pivots 15 and 16 is equal to the distance between the pivot 19 and the pivots 20 and 21. A second linkage first arm 23 has a first pivot 24, a second pivot 25 and a third pivot 26. The pivot 24 of the arm 23 is operatively connected to the second pivot 16 of the arm 14 and the pivot 25 of the arm 23 is operatively connected to the pivot 20 of the first linkage second arm 18. The pivots 24 and 25 are separated from each other by a distance d'' . A second linkage second arm 30 has a first pivot 31 and a second pivot 32. The first pivot 31 is pivotally connected to the third pivot 21 of the first linkage second arm 18. A second linkage third arm 35 has a first pivot 36 and a second pivot 37 and a position thereon described by the letter "p." The first pivot 36 of the arm 35 is operatively connected to the pivot 26 of the second linkage first arm 23. The second pivot 37 of the second linkage third arm 35 is operatively connected to the pivot 32 of the second linkage second arm. The pivots 36 and 37 are separated by a distance d''' . Beneath the apparatus 10 is disposed a plane 40. The plane 40 supports a fixed base 41. A base pivoted 42 is supported by the base 41 and is in operative engagement with the base arm 11 of the apparatus 10. Each of the pivots of the apparatus 10 with the exception of the base pivot 42 is adapted to pivot about axes which are parallel to each other. The pivot 42 is so constructed and arranged so as to permit rotation about an axis which lies in a plane lying generally normal to the axis of the pivots of the apparatus 10.

Operation of the linkage of the apparatus 10 is most readily understood by considering the apparatus to consist of two 4-bar linkages assembled from six arms wherein two of the arms have three pivots and each represents two bars of different interconnected 4-bar linkages. Thus, the first linkage consists of the arms or portions of arms joining the pivots 12, 16, 19 and 20. The second 4-bar linkage consists of the portion of the arms joining the pivot points 20, 26, 37 and 21. The point "p" on the arm 35 and indeed any point on the arm 35 will then trace an arc of a circle if both the first and second 4-bar linkages are parallelograms. This relationship holds true regardless of the relative magnitude of the parallelograms. If either one of the 4-bar linkages does not consist of a parallelogram, for example, if the distance d were not equal to d'' , a non-circular curve would be traced and similarly, if d' and d''' were unequal, a non-circular curve would be traced. Beneficially, by providing the pivot 42, rotation of the apparatus 10 about the pivot 42 permits the generation of a spherical segment. Such an apparatus, by means of the addition of suitable accessories such as a brick-laying machine at point "p" is capable of generating a brick dome or enclosure with-

3

out the necessity of using templates. Advantageously, such bricks may be layed in a spiral manner or alternately in a tiered fashion eliminating the necessity of scaffolding and the like. The addition of a suitable drive means to any one of the arms other than the base arm permits the positioning of the point "p" at any desired location along a circular arc within the limit of travel determined by the mechanical interference of the arms.

In FIGURE 2 there is illustrated an apparatus generally designated by the reference numeral 50. The apparatus 50 comprises a base arm 51 pivotally connected to a first arm 52 and a second arm 53, a third arm 54 and a fourth arm 55 and pivotally connected to a fifth arm 56 which carries a radiation source 57. Each of the arms is pivotally connected in the manner of the arms of the apparatus 10 in such a way that two 4-bar linkages are formed each having the form of a parallelogram, thus permitting the radiation source 57 to be moved through an arc of a circle having a center on a point remote from the apparatus 50. The embodiment is particularly advantageous for the rotation of radar antennas and to rotate heavy equipment where a circular track is undesirable or inconvenient and for the support of radioactive materials which emit high energy ionizing radiation, and are adapted for the treatment of a point within a body within which a center of rotation is undesirably positioned.

As is apparent from the foregoing specification, the apparatus of the present invention is susceptible of being embodied with various alterations and modifications which may differ particularly from those that have been described in the preceding specification and description. For this reason, it is to be fully understood that all of the foregoing is intended to be merely illustrative and is not to be construed or interpreted as being restrictive or otherwise limiting of the present invention, excepting as it is set forth and defined in the hereto appended claims.

What is claimed is:

1. A mechanical linkage having at least six arms, seven pivot points and two 4-bar linkages which comprise in cooperative combination

a base arm having a first pivot and a second pivot, the first and second pivots of the base arm being separated by a distance d ,

a first linkage first arm having a first pivot and a second pivot, the first pivot of the first linkage first arm being operatively connected to the first pivot of the base arm, a first linkage second arm having a first pivot, a second pivot and a third pivot, the first pivot of the first linkage second arm being operatively connected to the second pivot of the base arm,

a second linkage first arm having a first pivot, a second pivot and a third pivot, the first pivot of the second linkage first arm being in operative connection with

4

the second pivot of the first linkage first arm, the second pivot of the second linkage first arm being operatively connected with the second pivot of the first linkage second arm,

the first linkage second arm having the second and third pivots disposed about equidistant from the first pivot and the second linkage first arm having the first and second pivots thereof disposed about equidistant from the third pivot,

a second linkage second arm having a first and second pivot, the first pivot of the second linkage second arm being pivotally attached to the third pivot of the first linkage second arm,

a second linkage third arm having first and second pivots, the first pivot of the second linkage third arm being pivotally attached to the third pivot of the second linkage first arm and the second pivot of the second linkage third arm being pivotally attached to the second pivot of the second linkage second arm, all of the arm pivots pivoting about generally parallel axes.

2. The linkage of claim 1 wherein the distance between the second and third pivots of the first linkage second arm is equal to the distance d .

3. The linkage of claim 2 wherein the distance between the second and third pivots of the second linkage first arm and the distance between the first and second pivots of the second linkage third arm are equal.

4. The linkage of claim 1 wherein the distance between the first and second pivots of the base arm and the first and second pivots of the second linkage third arm are equal.

5. The linkage of claim 1 including a base arm pivot having an axis of rotation substantially perpendicular to the axis of rotation of the axes of rotation of the base arm first and second pivots, a base in operative engagement with the base arm pivot.

6. The apparatus of claim 1 wherein a radiating means is affixed to the second linkage third arm.

7. The linkage of claim 6 wherein the radiating means is directed toward a common point remote from the base arm as the first and second arms of the first linkage are pivoted about the first and second pivots of the base arm.

References Cited by the Examiner

UNITED STATES PATENTS

2,414,684	1/1947	Wohlforth	74-103	X
2,506,151	5/1950	Hoven et al.	74-99	

FOREIGN PATENTS

210,712	8/1960	Austria.
1,266,561	6/1961	France.
763,977	12/1956	Great Britain.

MILTON KAUFMAN, *Primary Examiner.*

D. H. THIEL, *Examiner.*