

(12) STANDARD PATENT APPLICATION (11) Application No. AU 2003262425 A1
(19) AUSTRALIAN PATENT OFFICE

(54) Title
Gaming Machine

(51)⁷ International Patent Classification(s)
A63F 013/08 A63F 013/10

(21) Application No: **2003262425** (22) Date of Filing: **2003.11.19**

(30) Priority Data

(31) Number (32) Date (33) Country
2002-335010 2002.11.19 JP

(43) Publication Date: **2004.06.03**
(43) Publication Journal Date: **2004.06.03**

(71) Applicant(s)
Aruze Corporation

(72) Inventor(s)
Okada, Kazuo

(74) Agent / Attorney
Spruson & Ferguson, Level 35 St Martins Tower 31 Market Street, Sydney, NSW, 2000

GAMING MACHINE

Abstract of the Disclosure

A gaming machine (1) includes an upper display panel (6) of an electrical
5 display able to change the contents of display. The panel display has a transparent acryl
board (19) as a protective cover, an LCD as an electrical display, and a cold-cathode tube
as a backlight. The display contents include a pay table and characters.

FIG.2

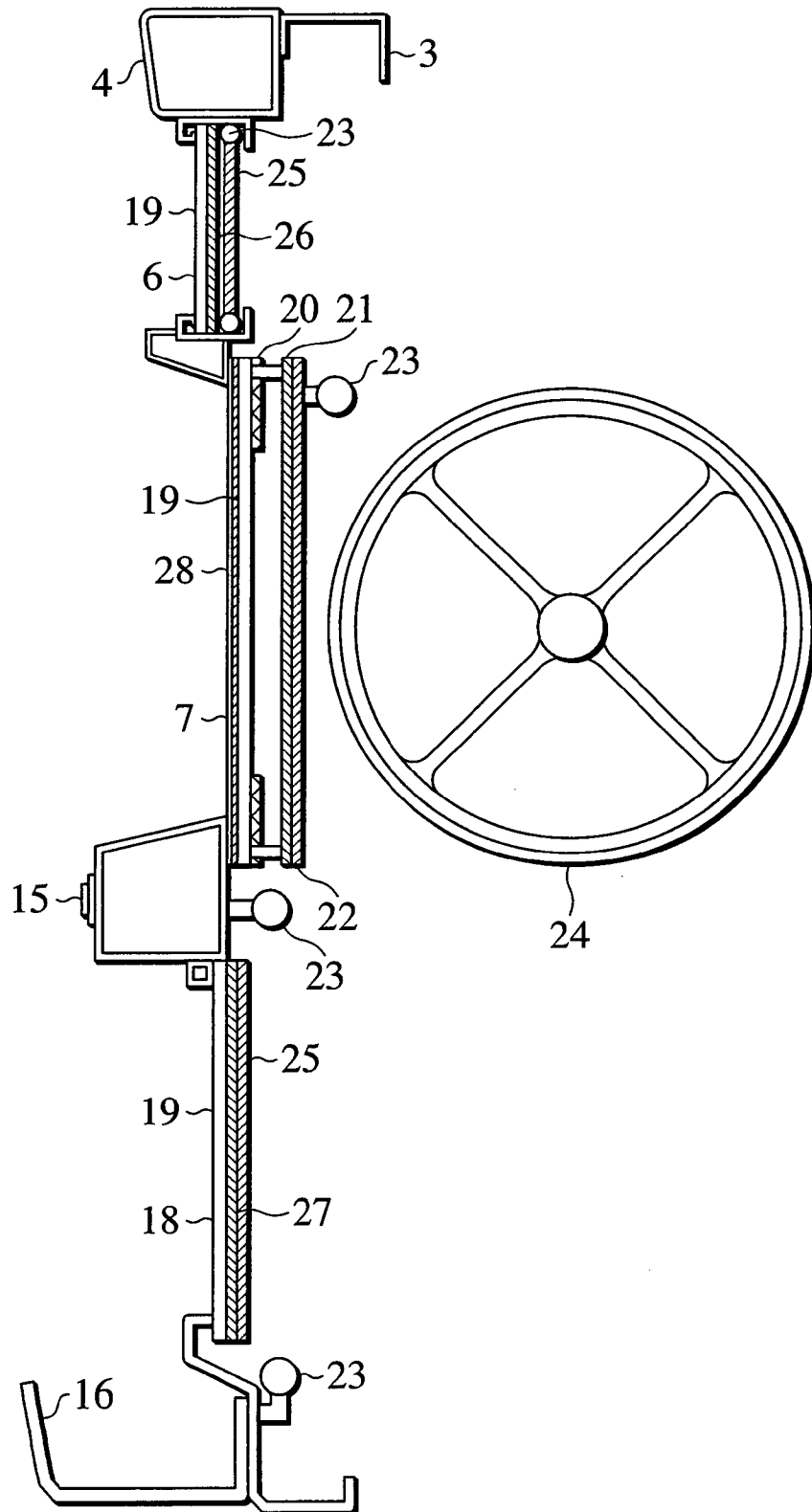

AUSTRALIA

PATENTS ACT 1990

COMPLETE SPECIFICATION

FOR A STANDARD PATENT

Name and Address of Applicant :	Aruze Corporation 1-25, Ariake 3-chome Koto-ku Tokyo Japan
Actual Inventor(s):	Kazuo Okada
Address for Service:	Spruson & Ferguson St Martins Tower Level 35 31 Market Street Sydney NSW 2000 (CCN 3710000177)
Invention Title:	Gaming Machine

The following statement is a full description of this invention, including the best method of performing it known to me/us:-

IP Australia

Documents were received on:

19 NOV 2003

sydney

Batch No:

GAMING MACHINE

CROSS REFERENCE TO THE RELATED APPLICATION

This application is based upon and claims the benefit of priority from the
5 prior Japanese Patent Application No. P2002-335010, filed on November 19,
2002; the entire contents of which are incorporated herein by reference.

BACKGROUND OF THE INVENTION

1. Field of the Invention

10 The present invention relates to symbol combination gaming machines
such as slot machines and pachinko machines, having variably displaying means
for variably displaying various kinds of symbols and the function of controlling
the variable display and awarding a payoff to a player according to the outcome.

2. Description of the Related Art

15 The slot machine is a typical gaming machine of this type. The slot
machine has a plurality of rotary reels with a plurality of symbols arranged on
their peripheries, and is designed to pay out coins or prizes upon winning which
occurs when symbols on the reels which stop rotating are in a predetermined
combination such as the alignment of the same symbols. It is a remarkable
20 feature of the slot machine that it has "chance" factors, generally involving
various sorts of chance to get a prize so that a player cannot fully control the
outcome of a game by his or her skill.

Various methods have conventionally been taken to provide the "chance"
factors. The recent mainstream of the slot machine adopts a control scheme
25 called a "pre-stage determination" using a microcomputer, in which a winning
combination selection is made by software and stop control of the reels is
executed according to the selection. A slot machine described in Japanese
Examined Patent Publication No. 3-72313, for example, relates to a slot machine
with stop buttons, a so-called pachislo machine, having random number
30 selecting means for selecting a random number in response to a player's
operation of a start lever and a winning combination selecting table in which

winning combinations are categorized into random number ranges of "large hit," "medium hit" and "small hit," according to the magnitudes of the symbols.

When a random number selected is included in a winning area of the winning combination selecting table, the corresponding winning combination is

5 determined as a winning combination, and the hit (winning) flag of the winning combination is set. Winning flags include those of a winning combination called a "small winning combination," which indicate that a combination of given symbols (such as "BELL" symbols or "CHERRY" symbols) along an activated pay line causes the payout of some ten coins, and those of a winning
10 combination called a "bonus winning combination," which indicate that an alignment of given symbols (such as "7" symbols or "BAR" symbols) causes a state where winning is more likely to occur than in a normal game state during a certain number of games and leads to the payout of a large amount of some 100 to 400 coins.

15 A state in which a winning flag is set is generally called "internal winning," in which the winning combination along a pay line is enabled but a win does not yet actually occur. To win, the operation of "observation push" in the timing (generally within four symbol segments) to stop rotating winning combination along a pay line is required. If the control timing is bad, no
20 winning occurs despite internal winning, that is, what is a commonly called "miss" occurs.

The miss generally results from failure in observation push and has some patterns. In a first pattern, a target symbol is determined but a player cannot identify varying symbols and performs a stopping operation in a hit-or-miss
25 manner and fails. In a second pattern, there is a plurality of possible winning combinations internally selected for a game and a player cannot determine which symbol to target for stopping and performs the stopping operation in a hit-or-miss manner and fails.

In the former, familiarization of observation push can increase precision
30 to some degree. In the latter, a player even skilled in observation push cannot expect an increased precision of observation push because he or she needs to be

aware of the internal winning state which cannot be seen.

If information about an internal winning combination is given, a game state like a bonus game in which a large amount of coins can be won can be provided even in a normal game state. There is a gaming machine employing such a gaming feature of the pachislo machine and having a function which is popularly called "assist time (AT)." When predetermined conditions are met, the gaming machine lets a player know of an internal winning and also the kind of internal winning combination to reduce misses and pays out a larger amount of coins than in a normal game which gives no information. AT is a "normal game state" among "game states" to be described below. An actual payout of coins may be made in a scheme comparable to that of a bonus game.

There is also a function of "super time (ST)" for making large or small payouts of coins by providing or not providing support for leading an "internal winning state" to a "win." A plurality of "stop tables" is prepared for determining the number of symbol segments by which a rotating reel for which a player presses the stopping button for stop control is rotated before being actually stopped from the symbol position at the stop control. Every time a winning combination is internally selected, a stop table for use is determined by random number selection. Winning does not occur unless a stopping operation is performed in a stop order specified in the stop table even if observation push are made in good timing to stop the winning combination along an activated pay line. Information on the stop table selected may be given or not given. Like the above-described "AT function," the "ST function" provides a payout of a large amount of coins as in a bonus game.

If there are three stopping buttons for stopping a left reel, center reel and right reel, for example, there are six pressing orders "left, center, right," "left, right, center," "right, center, left," "right, left, center," "center, right, left," and "center, left, right." Winning does not occur unless pressing is performed in an operating order specified in a stop table determined by random number selection.

During actual play, a game is switched between a special game state in which winning occurrence probability is increased as compared with a normal

game as described above, and a normal game state in which the special game state does not occur, according to gaming status. In either state, it is required for a player to stop and display a predetermined winning combination along a pay line in order to actually win a payout of coins. A typical gaming machine has a plurality of winning manners with different pay amounts. There are a “CHERRY” winning combination and a “BELL” winning combination as small winning combination, and a “big bonus” winning combination as a bonus winning combination, for example.

Winning combinations are associated with their respective pay amounts in a pay table displayed on a display panel to be seen by a player (see, e.g., Japanese Patent Laid-open Publication No. 6-261972). The display panel is comprised of a transparent acryl board and a translucent cell sheet printed with winning combinations and pay amounts superimposed on the acryl board. The graphics are illuminated by light such as a fluorescent lamp from within the gaming machine. A typical slot machine has a plurality of display panels as described above. Specifically, the slot machine is provided with a reel display panel having in its middle a display window through which a player can see reels provided within the gaming machine, an upper panel having a smaller area than the reel display panel provided above the reel display panel, and a lower panel usually printed with characters of the pachislo gaming machine and the name of the machine, provided below the reel display panel.

In a typical pachislo gaming machine, the same material is used for the cabinet and the front door in view of production efficiencies and costs. Display panels are printed with patterns according to the theme of the machine, serving to differentiate the gaming machine from other gaming machines.

Display panels are printed with different patterns for different machines. If products are left unsold, for example, display panels of the products cannot be used for other products, unlike the cabinet and the front door, resulting in a bad inventory. The assembly of the product requires the step of mounting the display panel unit to the front door, resulting in an increased number of production steps.

SUMMARY OF THE INVENTION

It is an object of the present invention to solve the problem of bad inventory caused by production of different display panels for different products, reduce the number of steps conventionally required for assembling display panels, and provide gaming machines with good cost performance.

A gaming machine according to a first aspect of the present invention comprises a variable display unit for variably displaying a plurality of symbols; a selector for selecting a winning combination; and an electrical display provided above the variable display unit.

In this invention, the electrical display constitutes an upper panel display provided above the variable display unit, on which various kinds of game information including pay tables, character images and a name logo are displayed. The electrical display may be a liquid crystal display, CRT display, electroluminescent display, plasma display, or the like.

The above configuration can solve the problems of bad inventory and increased assembly steps caused by use of physical acryl boards and pictorial cell sheets for display panels, resulting in the provision of gaming machines with good cost performance.

According to a second aspect of the present invention, the gaming machine further comprises a translucent electrical display provided in front of the variable display unit.

The reel display panel generally has a central portion made from a transparent glass plate or acryl board to allow rotary reels provided inside the cabinet to be seen. In this invention, the translucent electrical display is provided in front of the rotary reels to enhance the displaying effects. On the translucent electrical display, various images are displayed with variations in game state.

The above configuration allows appropriate display of various symbols on the reel display panel on which fixed symbols have conventionally been displayed, and provides a reel display panel with the visibility of reel symbols by

use of the translucent electrical display for the electrical display.

According to a third aspect of the present invention, the gaming machine further comprises a special game controller for generating a special game state which gives an advantage to a player based on a predetermined condition; in
5 which, the translucent electrical display executes a shielding control for making the variable display unit invisible to the player during the special game state, based on a prescribed condition.

The translucent liquid crystal display enables effective display control in conjunction with reel movement control in a special game state which gives
10 advantage to a player. When the special game is an ST game in which a player is given advantageous information about a stop order, for example, translucent control is executed only for a reel to be stopped and shielding control is executed for the other reels, which is an exemplary possible displaying manner.

The above configuration allows a player to play an ST game without
15 turning the eyes from a video display on which a stop order is displayed to reels to perform a stopping operation in the ST game, reducing fatigue of the player. Instantaneous switching between transmitting and shielding can be done according to game states and shielded areas can be controlled by software, so that more detailed display control becomes possible.

20 The above configuration can solve the problems of bad inventory and increased assembly steps caused by use of physical acryl boards and pictorial cell sheets for display panels, resulting in the provision of gaming machines with good cost performance.

25 BRIEF DESCRIPTION OF THE DRAWINGS

FIG. 1 is a perspective view of the outside of a pachislo machine according to an embodiment of the present invention;

FIG. 2 is a cross-sectional view of a front door;

FIG. 3 is a block diagram of a main control circuit;

30 FIG. 4 is a block diagram of a sub control circuit;

FIG. 5 is a block diagram of an image control circuit;

FIG. 6 is a view of display panels;

FIG. 7 is a diagram of pay lines;

FIG. 8 is a diagram of reels and back lamps;

FIG. 9 is a diagram of rows of symbols displayed on the peripheries of
5 reels;

FIG. 10 shows winning combinations and pay amounts of winning combinations;

FIG. 11 shows stop tables to be selected upon internal winning of
"BELL" winning combination;

10 FIG. 12 shows a winning combination selecting table;

FIG. 13 is a diagram of command lists to be transmitted to the sub control circuit;

FIGS. 14A to 14C are enlarged views of a reel display panel;

FIG. 15 is an enlarged view of the reel display panel;

15 FIGS. 16A to 16C show display screens in an ST game;

FIGS. 17A to 17C show display screens in an ST game;

FIGS. 18A to 18C show informational display screens;

FIGS. 19A and 19B show informational display screens;

20 FIG. 20 is an informational display occurrence and display type determining table;

FIGS. 21A and 21B are BR occurrence and BR continuation determining tables;

FIGS. 22A and 22B illustrate a support menu;

FIG. 23 is a diagram of a payout scheme setting screen;

25 FIG. 24 is a diagram of a payout scheme setting screen;

FIG. 25 is a diagram of a payout scheme setting screen;

FIGS. 26A and 26B show pay tables;

FIG. 27 is a flowchart of a process at a main control circuit;

FIG. 28 is a flowchart of a process at the main control circuit;

30 FIG. 29 is a flowchart of a process at the main control circuit;

FIG. 30 is a flowchart of an initialization process;

- FIG. 31 is a flowchart of interrupt process 1;
 FIG. 32 is a flowchart of a main process at a sub control circuit;
 FIG. 33 is a flowchart of a parameter changing process;
 FIG. 34 is a flowchart of the parameter changing process;
 5 FIG. 35 is a flowchart of a payout/probability changing process;
 FIG. 36 is a flowchart of the payout/probability changing process;
 FIG. 37 is a flowchart of an input process;
 FIG. 38 is a flowchart of a starting display control process;
 FIG. 39 is a flowchart of a BR occurrence determining process;
 10 FIG. 40 is a flowchart of a BR execution process;
 FIG. 41 is a flowchart of a display control process at the stop of the reels;
 FIG. 42 is a flowchart of a display control process at the end of a game;
 FIG. 43 is a flowchart of an informational display occurrence process;
 and
 15 FIG. 44 is a flowchart of a parameter update process.

DESCRIPTION OF THE PREFERRED EMBODIMENTS

FIG. 1 is a perspective view of the outside of a slot machine with stop buttons, a so-called pachislo machine as a gaming machine embodying the present invention. The pachislo machine 1 has a front door 3 openably and closably attached to a box-shaped cabinet made from plywood. An upper portion of the front door 3 is provided with a game state indicator lump 4 which flashes light in different indication modes upon the occurrence of a bonus game, error and the like, speakers 5L and 5R which generate sound effects, error sounds and the like during a game, and an upper display panel 6 on which pay amounts of winning combinations and a brief description of the game are displayed. A liquid crystal display (LCD) is provided inside the upper display panel 6, on which a variety of data is displayed based on pay amount data of winning combination and the like stored in a ROM. A reel display panel 7 having a substantially vertical surface is provided in the middle of the front door 3.

Left below the reel display panel 7, a 1-BET switch 8, a 2-BET switch

and a MAXBET switch are provided. When there is a credit of coins, a press of the 1-BET switch 8 causes one coin to be bet on a game. A press of the 2-BET switch 9 causes two coins to be bet on a game. A press of the MAXBET switch 10 causes three coins, a maximum number of coins to be bet on a game, to be bet on a game. The operation of these BET switches activates a predetermined pay line(s). A coin slot 11 is provided below right of the reel display panel 7.

A credit/payout (C/P) switch 12 for switching between credit and payout of coins won by a player in a game with push-button control is provided at the left of a middle portion of the front door 3. With the switching of the C/P switch 12, coins are paid out to a coin return 17 provided in a lower portion of the front door 3. The paid-out coins are accumulated in a coin tray 16. A start lever 13 is provided on the right of the C/P switch 12, rotatably over a predetermined angle range. When a player operates the start lever 13, reels provided inside of the reel display panel 7 start rotating.

A stop controller 14 for stopping the reels rotating is provided in a central portion of the front door 3, constituting a stopping means. The stop controller 14 is provided with a left stop button 15L, a center stop button 15c and a right stop button 15R. A player can determine an order in which to press the stop buttons 15L, 15C and 15L at will. A stop control performed when all the reels are rotating is generally referred to as a "first stop control," and a next stop control a "second stop control," and a final stop control a "third stop control." In this embodiment, the press of the left stop button 15L as the first stop control is referred to as "regular-order stopping," the press of the center stop button 15C as the first stop control "center-start stopping," and the press of the right stop button 15R as the first stop control "reverse-order stopping."

A gaming machine with three stop buttons has total of six stop control orders. Pressing the left stop button 15L as the first stop control, the center stop button 15C as the second stop control and the right stop button 15R as the third stop control is referred to as "left, center, right stopping." Pressing the center stop button 15C as the first stop control, the left stop button 15L as the second stop control and the right stop button 15R as the third stop control is referred to

as "center, left, right stopping." Pressing the center stop button 15C as the first stop control, the right stop button 15R as the second stop control and the left stop button 15L as the third stop control is referred to as "center, right, left stopping." Pressing the left stop button 15L as the first stop control, the right stop button 15R as the second stop control and the center stop button 15C as the third stop control is referred to as "left, right, center stopping." Pressing the right stop button 15R as the first stop control, the left stop button 15L as the second stop control and the center stop button 15C as the third stop control is referred to as "right, left, center stopping." Pressing the right stop button 15R as the first stop control, the center stop button 15C as the second stop control and the left stop button 15L as the third stop control is referred to as "right, center, left stopping."

A lower display panel 18 on which the name of the pachislo machine 1, characters appearing in the game and the like are displayed is provided below the stop controller 14. An LCD is provided inside of the lower display panel 18, on which various images are displayed on the basis of image data stored in a sub control circuit which will be described below.

FIG. 2 is a cross-sectional view of the front door 3 of the pachislo machine 1. The front door 3 has three display panels, the upper display panel 6, reel display panel 7 and lower display panel 18 from top to bottom, on which the name logo, characters and images according to game states are displayed. The reel display panel 7 has a lamination of a touch panel 28 for detecting a coordinate position of a player's touch, a transparent acryl board 19 as a protective cover, a pictorial sheet 20 of a transparent film on which various graphics are printed, facing the inside of the transparent acryl board 19, a reel LCD 21 of a transparent LCD such as an ITO, and an electronic shutter 22 of a liquid crystal film or the like. Cold-cathode tubes 23 serving as a back light of the reel LCD 21 and a lighting system for illuminating symbols on reels 24L, 24C and 24R are provided at upper and lower portions of the inside of the reel display panel 7. Graphics printed on the pictorial sheet 20 are always visible to a player in any display control state of the pachislo machine 1. The reel LCD 21 constitutes a display area for image displays such as a big winning display and

various informational displays. The electronic shutter 22 can switch between transmitting and shielding of predetermined areas, depending on its voltage applied state, that is, it allows switching between the visible state and the invisible state of symbols on the reels 24L, 24C and 24R through the reel display panel 7 so as to switch video display on the reel LCD 21 between a normal display (in which only images displayed are visible with the reels 24 shielded by the electronic shutter 22) and a translucent display (in which reel symbols are visible through images displayed).

The upper display panel 6 is provided above the reel display panel 7. The upper display panel 6 includes, on the inside of a transparent acryl board 19 as a protective cover, an upper LCD 26, a cold-cathode tube 23 as a backlight source, and an optical waveguide 25 for transmitting light from the cold-cathode tube 23 over the entire LCD 26.

The lower display panel 18 is provided below the reel display panel 7. The lower display panel 18 includes, on the inside of a transparent acryl board 19 as a protective cover, a lower LCD 27, a cold-cathode tube 23 as a backlight source, and an optical waveguide 25 for transmitting light from the cold-cathode tube 23 over the entire LCD 27.

FIG. 3 shows a block diagram of an exemplary circuit for the operation of the pachislo machine 1 shown in FIG. 1. A game control means of this embodiment largely consists of two control circuits. A main control circuit 101 controls various peripherals electrically connected thereto, based on input signals from various detecting means. A sub control circuit 201 controls images displayed on various LCDs and sound effects produced by the speakers 5L and 5R, based on game information sent from the main control circuit 101 and inputs from the touch panel 28 provided at the reel display panel 7.

The main control circuit 101 has a microcomputer 102 as the main component disposed on a circuit board and also has a circuit for random number selection. The microcomputer 102 includes a ROM 104 in which game programs and data are stored, a CPU 103 for performing control operations according to the game programs in the ROM 104, and a RAM 105 providing

work area required for the control operations.

Connected to the CPU 103 are a clock pulse generator 106 for generating reference clock pulses, a divider 107, a random number generator 108 for generating random numbers for selection, and a sampler 109 for selecting a
5 random number in response to a signal from the start lever 13 described below. The microcomputer 102 may alternatively perform random number selection by software processing as a random number selecting means. In that case, the random number generator 108 and the sampler 109 can be eliminated.

The ROM 104 in the microcomputer 102 stores, in addition to the control
10 programs for controlling various operations of the pachislo machine 1, a winning combination selecting table for use in the determination of win or loss of a random number obtained by the operation of the start lever 13 in a probability selection process to be described below, a stop table for determining the stop positions of the reels 24L, 24C and 24R according to the operations of the stop
15 buttons 15L, 15C and 15R, various game information commands to be sent to the sub control circuit 201, and the like.

The various peripherals (actuators) are connected to the CPU 103 via an input/output (I/O) port 110.

A motor drive circuit 111 drives stepping motors 112L, 112C and 112R
20 for rotating the reels 24L, 24C and 24R, respectively, according to drive signals from the CPU 103. The motor drive circuit 111 stops the stepping motors 112L, 112C and 112R in response to stop control signals from the CPU 103.

A hopper drive circuit 113 drives a hopper 114 as a coin payout device based on a payout command from the CPU 103.

25 A seven-segment drive circuit 122 drives various displays (bonus information display 33, credit display 34 and payout display 35) of seven-segment LEDs.

A lamp drive circuit 116 controls the lighting of various indicators in the form of lamps (REPLAY lamp 30, WAIT lamp 31, WIN lamp 32 and START
30 lamp 36).

There are other display means such as the reel LCD 21, electronic shutter

22 and reel backlights, which are controlled by the sub control circuit 201.

Main input signal generating means for generating input signals necessary for the microcomputer 102 to generate control signals to the drive circuits includes the start lever 13, the 1-BET switch 8, the 2-BET switch 9, the
5 MAXBET switch 10, the C/P switch 12, an inserted coin sensor 117, a reel stop signal circuit 118, a reel index detector circuit 115 and a payout detector circuit 119. These are also connected to the CPU 103 via the I/O port 110.

The start lever 13 detects a start control by a player. The inserted coin sensor 17 detects coins inserted through the coin slot 11 and passed through a
10 selector for screening irregular-shaped coins and the like. The reel stop signal circuit 118 detects the presses of the stop buttons 15L, 15C and 15R and generates stop signals. The reel index detector circuit 115 receives signals from rotational reference position detection switches in the stepping motors 112L, 112C and 112R and supplies symbol position reset signals to the CPU 103. The
15 payout detector circuit 119 receives signals from a coin detector 120 in the hopper 114 and supplies payout amount signals to the CPU 103.

Now a description will be made of how the drive circuits are controlled during the sequence of a game. The random number generator 108 has
20 generated random numbers in a certain numeric range since the power switch of the pachislo machine 1 was turned on. If the inserted coin sensor 117 detects coin insertion by a player or there is a credit of coins, a bet operation with the 1-BET switch 8, 2-BET switch 9 or MAXBET switch 10 causes the reel LCD 21 to display an active line(s) according to the bet amount. As shown in the enlarged view of FIG. 7, a bet of one coin causes the center line L1 to be an
25 active pay line (hereinafter abbreviated as an active line), a bet of two coins causes the top line L2A and the bottom line L2B in addition to the center line L1 to be active lines, and a bet of three coins causes the center line L1, top line L2A and bottom line L2B and also diagonal lines L3A and L3B to be active lines.

Then, in the timing when the start lever 13 detects a game start by a
30 player, the sampler 109 selects a random number. The selected random number is checked against the winning combination selecting table stored in the ROM

104. When the number corresponds to a winning combination, the winning flag thereof is set. This software selection process is referred to as a "probability selecting process," and will be described in detail below.

Drive pulses are supplied to the stepping motors 112L, 112C and 112R through the motor drive circuit 111. The reels 24L, 24C and 24R start rotating. The CPU 103 monitors the drive pulses supplied and updates "pulse counters" provided in the RAM 105. When the values of the pulse counters monitored reach a predetermined value, the CPU 103 determines a one-symbol (one-segment) shift and adds 1 to the values of "symbol counters" provided in the RAM 105.

When the stepping motors 112L, 112C and 112R are adapted to rotate 360 degrees by 400 pulses and twenty-one symbols are arranged on a reel periphery, for example, about 19 pulses cause a one symbol segment shift. When the values of the pulse counters reach 19 pulses, the CPU 103 determines a one-symbol shift and adds 1 to the values of the "symbol counters."

Every time the reference points of symbols on the reels 24L, 24C and 24R pass the center line L1 shown in FIG. 7, index detection signals are generated and reset pulses are transmitted to the CPU 103 via the reel index detector circuit 115. The CPU 103 detects the input of the reset pulses and clears the values of the symbol counters in the RAM 105 to ensure consistency between symbol positions calculated by software and actually displayed symbol positions.

When the reels 24L, 24C and 24R are at constant-speed rotation after a lapse of a given time since the start of rotation, the stop buttons 15L, 15C and 15R can be operated. When a player performs stop controls, reel stop signals are supplied to the CPU 103 via the reel stop signal circuit 118. After software processing such as the selection of stop positions, stop pulses are supplied to the stepping motors 112L, 112C and 112R via the motor drive circuit 111 to stop the reels 24L, 24C and 24R.

In the stop control of the reels 24L, 24C and 24R, the CPU 103, upon receiving stop signals from the reel stop signal circuit 118, stores in a

predetermined area of the RAM 105 the code numbers of symbols along the center line L1 as stop control positions, and accesses the stop table in which stop control positions are associated with symbols to be stopped and displayed along the center line L1. The CPU 103 stores symbol stop positions corresponding to the stop control positions in a predetermined area of the RAM 105, calculates how many pulses (how many segments) to be supplied to stop and display the target symbols, supplies the calculated number of pulses, and then performs stop control.

When all the reels 24L, 24C and 24R are stopped, a winning search is performed. In the winning search, first, a symbol table stored in the ROM 104 and the symbol stop positions stored in the RAM 105 are checked to discover the stopped manner of the game. The symbol table corresponds to symbol rows printed on the peripheries of the reels 24L, 24C and 24R, and associates code numbers indicating the sequences of symbols from the reference positions with symbol codes corresponding to the code numbers, serving as software reel strips. Then, the presence or absence of winning on the active lines L1, L2A, L2B, L3A and/or L3B is determined by checking the stopped manner and a winning combination table stored in the ROM 104. The winning combination table associates winning combinations with the numbers of coins to be paid out upon winning. The winning combination table is switched when active winning combinations or pay amounts are changed for different game states, for example.

When determining "winning" in the winning search, the CPU 103 supplies a payout signal to the hopper drive circuit 113 to pay out a predetermined number of coins from the hopper 114. At that time, the coin detector 120 counts the number of coins paid out from the hopper 114 and stops the drive signal to the hopper drive circuit 113 to stop the coin payout when the counted number reaches the predetermined number.

The block diagram of FIG. 4 illustrates the arrangement of the sub control circuit 201. The sub control circuit 201 controls peripheries such as the LCDs and the speakers 5L and 5R for providing effects based on game information from the main control circuit 101 and input signals from the touch

panel 28. The function of the sub control circuit 201 can be realized by the main control circuit 101, in this case, it is not necessary for the sub control circuit 201 to be provided.

The sub control circuit 201 has a sub microcomputer 202 as the main component and includes an upper display panel image control circuit 250, a reel display panel image control circuit 251 and a lower display panel image control circuit 252 for driving the LCDs, a sound generator IC 230 for controlling the sounding of the speakers 5L and 5R, a power amp 231 as an amplifier, a reel back lamp control circuit 240, and an electronic shutter control circuit 270 for controlling the shielding of the reel display panel 7. These control circuits are arranged on a circuit board separate from that of the main control circuit 101.

The sub microcomputer 202 includes a sub CPU 203, a sub ROM 204 as a storage means, and a sub RAM 205. The sub control circuit 201 in FIG. 5 includes, like the main control circuit 101, a clock pulse generator, a divider, a random number generator and a sampler which are not shown. The sub ROM 204 stores a sequence program for communications with the main control circuit 101, a display/sound effect selecting table for selection from among various effects on the basis of game information received, a sound sequence program, and the like. The sub RAM 205 is used as work area for executing these control programs.

The sub CPU 203 determines which type of effect is to be provided by the various display/sound effect control circuits based on commands transmitted from the main control circuit 101, and transmits the determination to the control circuits.

The reel back lamp control circuit 240 is used for controlling image display such as winning displays and winning flag information.

The electronic shutter control circuit 270 controls the transmitting/shielding control of the electronic shutter 22 disposed between the reel LCD 21 and the reels 24L, 24C and 24R, based on whether a voltage is applied or not. Specified display areas are shielded based on a determination by the sub microcomputer 202 to shield the areas on the inside of the reel LCD 21

from the view of the player. During an ST game, a special game in which information on an appropriate stop order is given according to a selected stop table, for example, only a reel to be stopped first is made visible upon the operation of the start lever 13 and the other reels are shielded so as to let the
5 player know which reel to stop first.

Image control circuits include a plurality of control circuits for controlling the LCDs 21, 26 and 27 provided at the display panels 6, 7 and 18, that is, the upper display panel image control circuit 250, the reel display panel image control circuit 251 and the lower display panel image control circuit 252.
10 FIG. 5 illustrates a block diagram of the reel display panel image control circuit 251 as an exemplary block diagram of the image control circuits. The reel display panel image control circuit 251 controls images displayed on the reel LCD 21, including an image control CPU 253, an image control ROM 254, an image control RAM 255, an image ROM 257, a video RAM 258 and an image
15 control IC 256. The image control CPU 253 receives parameters determined by the sub microcomputer 202 via an image control circuit IN port 259, and determines display contents on the reel LCD 21 under an image control sequence program stored in the image control ROM 254. The image control ROM 254 stores a sequence program for receiving image display commands transmitted
20 from the sub microcomputer 202, an image control sequence program for controlling the image control IC 256 and the like. The image control RAM 255 is used as work area for executing the image control program.

The image control IC 256 creates an image according to the display contents determined at the image control CPU 253, using graphic data stored in
25 the image ROM 257, temporarily stores the image in the video RAM 258, and outputs the image to the reel LCD 21 via the image control circuit OUT port 260 in appropriate timing for display.

FIG. 6 is the front view of the pachislo machine 1, illustrating especially the upper display panel 6, reel display panel 7 and lower display panel 18. In
30 this embodiment, every display panel is provided with an LCD as an electrical display for displaying various images according to game states. In the reel

display panel 7, symbols on the reels 24L, 24C and 24R are visible through the reel LCD 21 and the electronic shutter 22. When the reel LCD 21 and the electronic shutter 22 are controlled to be transparent, reel symbols are visible to a player. When an image is displayed on the reel LCD 21 or the electronic shutter 22 is controlled to be opaque (to be a mask), reel symbols are invisible.

The lower display panel 18 has the lower LCD 27 on which the name of the machine and images according to the theme of the gaming machine are mainly displayed. In the figure, the name of the machine "DON-NAVI" is displayed. These images are displayed on the basis of image data stored in an image ROM of the lower display panel image control circuit 252 in the sub control circuit 201. Replacement of the sub control circuit 201 or the lower display panel image control circuit 252 for different models can eliminate the need to produce different lower display panels for different models and the need to attach different lower display panels in the production process, facilitating the production of various models.

The upper display panel 6 has the upper LCD 26 for mainly displaying a pay table. In this embodiment, pay amount is changeable by a certain input operation, and the contents of the pay table are displayed according to changed parameters. The details will be described below.

FIG. 8 is an enlarged view of the reels 24L, 24C and 24R. Reel strips 40L, 40C and 40R of the reels 24L, 24C and 24R are made of translucent film material, having on their surfaces different symbols such as "CHERRY" symbols and "7" symbols printed in light-transmitting colored inks. Remaining areas are masked with a light blocking ink. Lamp housings 41L, 41C and 41R are provided behind the reel strips 40L, 40C and 40R to prevent light emitted from lamps from affecting other symbol areas. Reel back lamps 42L, 42C and 42R are included in the lamp housings 41L, 41C and 41R, respectively. The reel back lamp control circuit 240 controls the flashing of the reel back lamps 42L, 42C and 42R based on parameters determined at the sub microcomputer 202. For example, the reel back lamps 42L, 42C and 42R behind symbols on a pay line are caused to flash at the payout of coins, or different flashing modes are

prepared for different internal winning combinations to display the setting of the respective winning flags, and thereby to let a player know which winning combination to stop.

5 FIG. 9 illustrates the reel strips 40L, 40C and 40R developed in a plan view. Each reel has twenty-one symbols. The symbols are given symbol numbers 1 to 21 which are stored in the ROM 104 in a symbol table. The symbols in symbol rows 40L', 40C' and 40R' are sequentially displayed in the order of the symbol numbers (from bottom to top) with the rotation of the reels 24L, 24C and 24R.

10 FIG. 10 is a diagram of a pay table showing pay amounts in association with winning combinations in different game states.

Internal winning, prize winning and game states will now be described. Internal winning is a state in which a random number selected is checked against the winning combination selecting table in the above-described probability
15 selecting process and determined as a win, and the winning flag of the corresponding winning combination is set.

All winning combinations generally have their respective winning flags. The winning flags are roughly classified into two categories by their characteristics. Those of one category is of winning combinations of relatively
20 small pay amounts called small winning combinations, which are not transferred to the next game. Those of the other category is of winning combinations called big bonus (BB) and regular bonus (RB) which increase probabilities of internal selection of winning combinations, each of which is not only effective in a game with the winning flag on but also transferred until winning occurs to provide
25 payout of a large amount of coins.

Small winning combinations include a "CHERRY" winning combination which gives a prize when stopped on the left reel 24L active line, a "BELL" winning combination and a "WATERMELON" winning combination which give a prize when three BELL or WATERMELON symbols are stopped along an
30 active line, for example. Bonus winning combinations include a regular bonus and a big bonus. A regular bonus (RB) occurs by the combination of

“BAR-BAR-BAR” along an active pay line, for example, and provides a first payout of fifteen coins at the winning. The RB is effective until twelve one-bet bonus games (called JAC games) are played or eight wins occur. A big bonus (BB) occurs by the combination of “RED 7-RED 7-RED 7” along an active line, for example, and provides a first payout of fifteen coins upon winning. During a BB round, a maximum of thirty games called normal games in which the winning probabilities of small winning combinations and RB are increased can be played. During this period, a maximum of three RB games can be played. RB winning occurs in a normal game by the combination of “BAR-BAR-BAR,” for example. RB winning in a normal game during a BB round occurs with the combination of “REPLAY-REPLAY-REPLAY.” The winning combination of the REPLAY symbols causes an automatic insertion of the same number of coins as the coins having inserted, so that the next game can be played without the insertion of coins. A single bonus (SB) occurs by the combination of “SWORD 7-SWORD 7-SWORD 7” along an active line, for example, and provides a first payout of fifteen coins at the winning. Then a JAC game can be played once. The SB is named with the word “bonus,” but permits no transferring of the winning flag. The winning flag is effective only in a game such as small winning combination.

Now game states will be described. Game states are generally classified into three states according to whether winning flags of bonus winning combinations are on and off. The three states are: a normal game state in which no bonus winning combinations have yet internally selected; a bonus internal winning state in which bonus internal winning occurs in the probability selecting process but the bonus winning combinations are not yet formed along an active line; and a bonus game state in which a bonus winning combination is formed along an active line during bonus internal winning and a bonus game is played.

The bonus internal winning state is further divided into a BB internal winning state and an RB internal winning state, according to the kinds of bonuses. The bonus game state is also divided into a BB game state and an RB game state.

In addition to the bonus game states, there are game states which give

advantage to a player to get a large amount of coins.

For example, a special state called a "C-Type" is known, in which two SB winning probability tables in a normal game, that is, a high probability table (e.g., an SB internal winning probability of 1/2) and a low probability table (e.g., an SB internal winning probability of 1/20), are prepared. When using the low probability table, whether to switch to the high probability table is determined by a selection (generally called a "launch selection"). Conversely, when using the high probability table, whether to switch to the low probability table is determined by a selection (generally called a "punk selection"). The number of coins is gradually increased in use of the high probability table.

Also, a special state called an "assist time (AT) function" is known. When several winning combinations which cannot occur at the same time are provided (e.g., the winning combinations of "BELL-BELL-RED 7," "BELL-BELL-BLUE 7" and "BELL-BELL-WHITE 7" with the symbols "RED 7," "BLUE 7" and "WHITE 7" on the right reel spaced from one another with four or more symbol segments therebetween), a player does not know which "7" to stop because they are not given information on the kind of the internal winning combination in a normal state, and theoretically has a 1/3 chance of winning after internal winning. In a state called an AT period in which information on the internal winning type is given, a player can know which "7" symbol to stop, so that precise observation push theoretically provides a 100% chance of winning after internal winning and the number of coins is gradually increased.

There is also a special state called a "super time (ST) function" in which, even if a winning combination is internally selected and precise observation push are done, a stop control for preventing formation of a winning combination is performed unless the winning combination is formed by stopping in a predetermined order. For example, when six kinds of stop order tables "No. 1" to "No. 6" are prepared for winning combination "BELL" as shown in FIG. 11 and "BELL" is internally selected in the probability selecting process, one of the stop tables is selected for use by a random number selection or the like. If the stop table of table "No. 3" is selected in a game, the first press of the center stop

button 15c, the second press of the left stop button 15L and the third press of the right stop button 15R lead to a win. The other five stop orders cause stop control to prevent an alignment of BELL symbols on an active line even when "BELL" is internally selected.

5 Information on a stop order is not given in a normal state, so that a player only has a 1/6 chance of winning in theory after internal winning. In a state called an ST period in which information on a selected stop table is given, in other words, information on an appropriate stop order is given, a player theoretically has a 100% chance of winning after internal winning, and coins are
10 gradually increased. In this embodiment, the pay amount of the same winning combination differs depending on the game state. For example, the WATERMELON winning combination provides a payout of three coins in a normal game state and in a bonus internal winning state, but provides a payout of fifteen coins in a normal game in a BB round. The combination
15 "REPLAY-REPLAY-REPLAY" is a REPLAY winning combination in a normal game state and in a bonus internal winning state. The combination, however, becomes an RB winning combination in a normal game in a BB round, and becomes a symbol winning combination with a payout of fifteen coins in a JAC game.

20 In this embodiment, the above described "ST" is adopted as an advantageous state for a player, in addition to bonus winning combinations. When a predetermined condition is met in a normal game, an ST game is operated. More specifically, upon the internal winning of the SB winning combination or the BELL winning combination, stop order information necessary
25 for the formation of the winning combination is given to a player. Under the internal winning of the SB winning combination or the BELL winning combination during the period of this special state, the player performs stopping operation in the given order without fail and wins a prize. In this embodiment, a certain input operation can change the pay amounts of the winning
30 combinations in the basic pay table shown in FIG. 10.

FIG. 12 shows the winning combination selecting table for use in the

above-described probability selecting process. A random number is selected from among the range of "0 to 16383." When the selected random number is in a winning range associated with a winning combination, the winning combination is internally selected. For example, when a random number selected in a game is "10000," the number is in the winning range of "2299" to "11024" of the BELL winning combination and the BELL winning combination is internally selected. When a random number selected in a game is "15000," the number is in the losing range of "13669 to 16383," and no winning combination is internally selected and the game is lost.

FIG. 13 illustrates tables of game information commands from the main control circuit 101. In this embodiment, the main control circuit 1 for controlling winning determination, coin payout and the like is formed on a separate board from that of the sub control circuit 201 for controlling the reel LCD 21 and the speakers 5L and 5R. Controls at the sub control circuit 201 require game information on the winning combination internal winning state and the stopped states of the reels 24L, 24C and 24R which is processed at the main control circuit 101. The two circuit boards are connected by a strait cable for sequential transmission of required information. Commands transmitted include a "start command" transmitted at the operation of the start lever 13 by a player, a "reel stop command" transmitted at a press of the stop button 15L, 15C or 15R for stopping the rotating reel 24L, 24C or 24R, a "1-game end command" transmitted at the completion of a game, a "parameter change request command" instructing parameter changes for changing pay amounts and internal winning probabilities at power-on of the pachislo machine 1, a "key switch off command" transmitted when a key switch is turned off, and an "initialization command" for instructing the LCDs to display initial screens.

FIGS. 14A to 14C illustrate several members constituting the reel display panel 7. FIG. 14A is a front view of the reel display panel 7. The reel display panel 7 is a transparent acryl board to which the touch panel 28 is laminated, serving as a protector against physical impact from the outside. FIG. 14B is a front view of the pictorial sheet 20. The pictorial sheet 20 is a transparent film

material on which a picture is printed in translucent inks. In this embodiment, a picture of a tree is printed at the left of the sheet 20. FIG. 14C is a front view of the electronic shutter 22. The electronic shutter 22 is made of a liquid crystal film and switches between transparent and opaque states, depending on a voltage applied state. Lamps at the right of the electronic shutter 22 and display areas of seven-segment displays are kept transparent regardless of the application and non-application of voltage, and are always visible to a player.

FIG. 15 is an enlarged view of the reel display panel 7 with the electronic shutter 22 in a shielding state (under no voltage application) in its entire area. This display is shown when the pachislo machine 1 is powered off, for example. The reels 24R, 24C and 24L are hidden behind the electronic shutter 22 and are invisible to a player. The pictorial sheet 20, which is provided in front of the electronic shutter 22 (on the side of a player) under no influence of the controlled state of the electronic shutter 22, is visible to a player. The lamp indicators and the seven-segment displays at the right of the reel display panel 7, which are disposed inward of the electronic shutter 22 in the cabinet, are visible to a player because the corresponding display areas of the electronic shutter 22 are always transparent.

FIGS. 16A to 16C illustrate display screens in an ST game as a special game state. FIG. 16A illustrates a screen on the reel display panel 7 displayed before a first stop control when "BELL" is internally selected in a game and the stop table No. 5 in FIG. 11 is selected, as an example of the image control in an ST game. In this embodiment, in the display control in an ST game, the electronic shutter 22 is made transparent only in its display area of a reel corresponding to a stop button to be pressed and is made to shield the other display areas to instruct an appropriate stopping operation. In the stop table No. 5, the right stop button 15R is a button to be pressed first, so that the display areas except the area of the right reel 24R are shielded to make only the right reel 24R rotating visible to a player to instruct the player to press the right stop button 15R. The transparent control herein means the control of the electronic shutter 22 so that reel symbols behind becomes visible. As long as reel symbols are

visible to a player, the electronic shutter 22 may be translucent or colored instead of being completely transparent. Similarly, the shielding state may include a translucent state to a degree that reel symbols behind are invisible, in addition to a state in which light is completely blocked off.

5 FIG. 16B illustrates a screen on the reel display panel 7 when the player presses the right stop button 15R in the state of FIG. 16A. The first press of the right stop button 15R is the correct stopping operation, so that only the BELL symbol as the internal winning combination is made visible in the display area of the right reel 24R which has been visible in its entirety during rotation in FIG. 10 16A, and the other display areas are shielded, thereby to let the player know that it was the correct stopping operation. The display area of the left reel 24L which has been shielded in FIG. 16A is made transparent to make the left reel 24L in rotation visible so as to instruct the player to stop the left reel 24L.

 FIG. 16C illustrates a screen on the reel display panel 7 when the player 15 presses the left stop button 24L in the state of FIG. 16A. The second press of the left stop button 24L is the correct stopping operation, so that only the BELL symbol as the internal winning combination is made visible in the display area of the left reel 24L which has been visible in its entirety during rotation in FIG. 16B and the other display areas are shielded so as to let the player know that it was 20 the right stopping operation. The display area of the center reel 24C which has been shielded in FIG. 16B is made transparent so that the center reel 24C in rotation is visible, thereby to instruct the player to stop the center reel 24C.

 FIG. 17A illustrates a screen on the reel display panel 7 when all stopping operations are correctly done in an ST game and a win occurs. In FIG. 17A, the 25 electronic shutter 22 is made transparent only at portions of the BELL symbols as the winning combination to make the BELL symbols on the reels 24L, 24C and 24R visible, and in alphabet "GET" is displayed on the reel LCD 21 to let the player know of the winning of a BELL prize.

 FIG. 17B illustrates a screen on the reel display panel 7 when stopping 30 operation is incorrectly done in an ST game and the game is lost. In FIG. 16B, for example, a screen is shown when, instead of the left stop button 15L being

pressed, the center stop button 15C is wrongly pressed. A large mark "X" is displayed in the center of the display to let the player know that it was a wrong stopping operation.

5 The screens provided in FIGS. 17A and 17B are displayed for a certain period of time. Thereafter, as shown in FIG. 17C, all the shielded areas are made transparent to terminate the display control in the game.

FIGS. 18A to 18C illustrate informational display screens generated with a predetermined probability after all the reels 24L, 24C and 24R are stopped. In a specific display sequence, first, the reels 24L, 24C and 24R in rotation are
10 displayed through the display panel 7 (FIG. 18A). A player then stops all the reels 24L, 24C and 24R by stopping operations (FIG. 18B). After the stopping of all the reels 24L, 24C and 24R, the electronic shutter 22 is made in a shielding state. The reels 24L, 24C and 24R which have been displayed are hidden behind the electronic shutter 22 as shown in FIG. 18C.

15 Then, an informational display based on an internal winning combination in the game is provided. In this embodiment, the informational display shows the degree of reliability in the setting of a bonus winning combination with different degrees of agreement between the displayed positions of the BELL symbols displayed on the reel LCD 21 and the stopped positions of the BELL
20 symbols on the reels 24L, 24C and 24R stopped and displayed. FIG. 21A illustrates an informational display occurrence table. The informational display occurrence table is referred to when "BB," "RB," "WATERMELON" or "SB" is internally selected in the probability selecting process and a determination of whether or not to provide an informational display is made. For example, when
25 "WATERMELON" is internally selected in the game and a random number for display selection is 15, an informational display occurs. When the internal winning symbol is "SB" and a random number for display selection is 15, an informational display does not occur.

FIG. 21B illustrates a display type selection table. The display type
30 selection table is referred to to determine the contents of informational display whose occurrence is determined with the informational display occurrence table.

The display contents are classified based on the degree of agreement between BELL symbol stopped positions on the reels 24L, 24C and 24R and BELL symbol stopped positions on the reel LCD 21. The higher the degree of agreement is, higher the probability of internal winning of a bonus winning combination. For example, "ALL" in the column of the number of BELL images in the figure indicates a complete agreement between those displayed positions. "Appearance - 2" indicates a disagreement at a maximum of two positions between those displayed positions. When the internal winning combination is "SB" and a random number for display selection is 118 in the game, for example, display of "Appearance - 4" is selected. If there are only two BELL symbols stopped and displayed on the reels 24L, 24C and 24R, a display manner in which all displayed positions are in disagreement is selected. If five BELL symbols are displayed, four displayed positions are shown to be in disagreement and one displayed position is shown to be in agreement.

FIGS. 19A and 19B illustrate a specific example of an informational display manner. FIG. 19A shows a screen displayed when the reels 24L, 24C and 24R are stopped in a manner shown in FIG. 18B and one of "Appearance - 2," "Appearance - 3," "Appearance - 4," and "Appearance - 5" in the display type selecting table in FIG. 21B is selected. In the reel stopped manner in FIG. 18B, BELL symbols are displayed on the center reel 24C center line and on the right reel 24R top line. On the reel LCD 21, however, BELL symbols are displayed on the center reel 24C bottom line and on the right reel 24R center line. The player can see that the informational display has low reliability with the disagreement in the displayed positions.

FIG. 19B shows a screen displayed when the reels 24L, 24C and 24R are stopped in a manner shown in FIG. 18B and "Appearance - 1" in the display type selecting table in FIG. 21B is selected. BELL symbols are displayed on the center reel 24C center line and on the right reel 24R top line. On the reel LCD 21, BELL symbols are displayed on the center reel 24C center line and on the right reel 24R center line. There is a disagreement in the displayed position on the right reel 24R, but there is an agreement in the displayed position on the

center reel 24C. The player can see that the informational display has high reliability.

FIG. 20 illustrates a table for determining BR occurrence and the number of BR continuations. In this embodiment, whether or not to generate a BR and the number of BR continuations are determined by a selection with a certain probability when a given winning combination is internally selected. In the table, a BR occurs at the rate of 16/128 when "WATERMELON" is internally selected, and at 11/128 when "TWO CHERRIES" are internally selected, and at 25/128 when no winning combination is selected.

FIG. 22 illustrates a support menu for a hall assistant to change or select a payout scheme of the pachislo machine 1. A support menu screen is displayed when the pachislo machine 1 is powered on with a key switch (not shown) provided in a power box in the pachislo machine 1 tuned on. The support menu includes three modes. In mode 1, pay amounts and internal winning probabilities of winning combinations are changed, in which a desired scheme is selected in a payout scheme setting screen to be described below. In mode 2, pay amounts and probabilities of occurrence of ST games of winning combinations are changed. In mode 3, six-stage setting is performed. Each mode is selected by touching its displayed area. At the completion of setting, "END" is selected to return to a normal game state.

FIG. 22B illustrates a password input screen which is displayed when mode 1 is selected. In mode 1, internal winning probabilities and pay amounts of winning combinations are changed to change the payout scheme of the pachislo machine 1. Variation of the payout scheme directly influences the business results of a pachinko hall. For increased security, an input of a password is required to proceed to the setting screen. The password specified is input with an alphabet input means of the touch panel 28 displayed in a lower central portion of the screen. After the input of the password, an "END" command in the alphabet input means is entered for verification of the password. When the input is correct, the setting screen is displayed. To end the input operation, "RETURN" is selected to return to the support menu screen.

FIGS. 23 to 25 illustrate payout scheme setting screens. In this embodiment, several payout scheme setting screens are prepared, including different pay amounts and internal winning probabilities of winning combinations. FIG. 23 illustrates a payout scheme setting screen A which is displayed after the input of a password on the password input screen. In the setting screen A, a standard payout scheme can be selected. In association with winning combinations listed in the left column of the screen, pay amounts and internal winning probabilities both in a normal game state and a normal game state during a BB round are specified. For example, "WATERMELON" in a normal game state has the internal winning probability of 141/16384 and the payout of three coins at winning. A screen switching icon is displayed in an upper central portion of the screen. Touching the icon switches the display to the next screen. If it is the screen to be used, a "DECISION" icon located in a left lower portion of the screen is touched for decision, and the display is returned to the support menu screen in FIG. 22A.

FIG. 24 illustrates a payout scheme setting screen B. In the setting screen B, pay amounts and internal winning probabilities of small winning combinations in a normal game state are increased (the internal winning probability of "WATERMELON" in a normal game state is to 356/16384, and the pay amount is to 15, and the internal winning probability of "BELL" is to 7688/16384, and the pay amount is to 6), to enable a longer normal game play. On the other hand, the internal winning probability of BB is 38/16384 to reduce the total odds to a certain value.

FIG. 25 illustrates a payout scheme setting screen C. In the setting screen C, the internal winning probability of "BELL" in a normal game is increased to lengthen game play. On the other hand, the number of available RB games in a BB round is reduced from 3 to 2 to reduce the total odds to a certain value.

As described above, the selection of one of the several prepared payout scheme setting screens allows the change of the game characteristics. It may be possible to make data values in the payout scheme setting screens changeable for

fine adjustments of the game characteristics.

FIGS. 26A and 26B illustrate pay tables to be displayed on the upper display panel 6. In this embodiment, as described above, the pay amounts and internal winning probabilities of winning combination are changeable. Display of the pay tables is controlled based on parameters determined. FIG. 26A illustrates a pay table to be displayed when the contents of the payout scheme setting screen A shown in FIG. 23 are selected.

FIG. 26B illustrates a pay table to be displayed when the contents of the payout scheme setting screen B shown in FIG. 24 are selected. In comparison with the pay table shown in FIG. 26A, the pay amount of "WATERMELON" in a normal game is changed from "3" to "15" and the pay amount of "CHERRY" is from "1" to "2."

Now the control operation of the main control circuit 101 and the CPU 103 will be described with reference to main processing shown in FIGS. 27 to 29.

First, in advance of a game start, the CPU 103 executes initialization (step [hereinafter abbreviated as S] 501). In the initialization, the above-described support menu screen is opened for changing pay amounts and internal winning probabilities before activating the pachislo machine 1. The details will be described below.

Then, the CPU 103 determines whether an automatic coin insertion request is made, that is, whether a replay is won in the previous game or not (S502). When the answer is "YES," the number of coins according to the insertion request are automatically inserted (S503), and the process proceeds to S505. When the answer is "NO" in S502, it is determined whether new insertion of coins is made, that is, whether there is an input from the inserted coin sensor 117 caused by a player's insertion of coins into the coin slot 11, or whether there is an input caused by the operation of one of the BET switches 8, 9 and 10 or not (S504). When the answer is "YES," the process proceeds to S505. When the answer is "NO," monitoring of an input signal is continued until a BET operation is performed.

Then, the CPU 103 determines whether there is an input caused by the

operation of the start lever 13 or not (S505). When the answer is "YES," the process proceeds to S506. When the answer is "NO," monitoring of an input signal is continued until the start lever 13 is operated.

Then, the probability selecting process is performed (S506). In the
5 probability selecting process, first a random number for selection is selected from among the range of "0 to 16383" by use of the random number generator 108 and the sampler 109. Then, using the winning combination selecting table (see FIG. 12) in which winning random number ranges (winning ranges) are determined according to game states and the number of inserted medals, it is determined
10 which winning range the selected random number is in and the corresponding internal winning combination (winning flag) is determined.

Then, a WIN lamp lighting process is executed (S507). In the WIN lamp lighting process, it is determined whether or not to light the WIN lamp
15 which is adapted to be lighted with a certain probability when a bonus winning combination is internally selected.

Then, game information at the start of a game is transmitted from the main control circuit 101 to the sub control circuit 201 (S508). Commands transmitted include, as shown in "start commands" of game information
20 commands in FIG. 13, a winning flag determined in the probability selecting process, a game state at that time and a stop table number determined according to the winning flag.

Then, it is determined whether or not a 1-game watchdog timer which has been set in the previous game counts to a specified time, e.g., 4.1 sec. (S509). When the answer is "YES," a 1-game watchdog timer for the next game is set
25 (S511). When the answer is "NO," after waiting a lapse of the rest of the specified time (S510), a 1-game watchdog timer for the next game is set (S511).

Then, the CPU 103 controls the motor drive circuit 111 to rotate the reels 24L, 24C and 24R (reel rotating process) (S512). In the reel rotating process, the reels 24L, 24C and 24R are accelerated from stopped states to a certain speed
30 at which a constant-speed rotating process is executed. Under the constant-speed rotation, the stop buttons 15L, 15C and 15R are activated to be

able to stop the reels 24L, 24C and 24R.

Then, the CPU 103 determines whether one of the stop buttons 15L, 15C and 15R is pressed (turned on) or not, that is, the presence or absence of a stop signal transmitted from the reel stop signal circuit 118 when one of the stop buttons 15L, 15C and 15R is pressed by a player (S513). When the answer is "YES," the process proceeds to S515. When the answer is "NO," the process returns to S514. In S514, it is determined whether the value of an automatic stop timer is "0" or not. Automatic stop means a process of automatically stopping the reels 24L, 24C and 24R rotating without the operation of the stop buttons 15L, 15C and 15R after a lapse of a certain period of time (e.g., 40 sec.) since a reel rotation start. When the answer is "YES," that is, when the automatic stop timer is "0," the process proceeds to S515 to automatically stop the reels 24L, 24C and 24R. When the answer is "NO," the process proceeds to S513 to continuously monitor reception of a stopping operation.

In S515, the CPU 103 executes a "segmental shift determination process." In the "segmental shift determination process," the number of symbol segments by which a reel corresponding to a pressed stop button is rotated before stopping is determined. The expression "segmental shift" means the number of symbols (the number of segments) by which the reels 24L, 24C and 24R are rotated before stopped (the actually stopped positions are referred to as "stopped positions") from the symbol positions (which are referred to as "stopping operation positions") displayed in display windows 43L, 43C and 43R when the stop buttons 15L, 15C and 15R are pressed.

Then, the CPU 103 controls the motor driving circuit 111 to stop a reel corresponding to a pressed stop button after rotation by a determined number of segmental shifts (S516).

Then, the CPU 103 transmits a "reel stop command" indicating the stop of the reel to the sub control circuit 201 (S517). The reel stop command includes, as shown in the "reel stop commands" in the game information commands in FIG. 13, a stopping order status (the how-manieth press the press is) and a stopped reel status (which reel is stopped).

Then, the CPU 103 determines whether all the reels 24L, 24C and 24R are stopped or not (S518). When the answer is "YES," the process proceeds to S519. When the answer is "NO," the process returns to S513 because there remains a rotating reel(s).

5 Then, the CPU 103 executes a winning search (S519). In the winning search, it is determined whether or not the symbol stopped manner corresponds to a win. When the answer is "YES," the winning flag of the corresponding winning combination is stored in the RAM 105. More specifically, the code numbers of symbols on the center line L1 are checked against the winning
10 combination selecting table stored in the ROM 104 for determination.

It is checked whether the prize flag agrees with the winning flag to determine whether the win is normal or not (S520). When the answer is "NO," an illegal error is displayed and the execution of the game program is terminated. When the answer is "YES" in S250, the payout of coins is performed in
15 accordance with the kind of the verified winning combination and the game state (S522).

When the game state is changed at the end of the game, the transition process is executed (S523). The process is executed when a final prize in a bonus game is won, or a bonus is internally selected in a game, or the
20 combination of "7-7-7" is stopped on an active line and a bonus game is started.

The kind of the verified winning combination, the game state and the like are transmitted to the sub control circuit 201 as a "1-game termination commands" shown in the game information command table in FIG. 13 (S524).

FIG. 30 illustrates a flowchart of initialization. First, the CPU 103
25 entirely clears the RAM 105 (S530) and then determines whether a key switch is on or not (S531). The key switch is used for determining whether to perform a parameter changing process for changing pay amounts or changing internal winning probabilities. When the power is turned on with the key switch turned off, the sub control circuit 201 executes the parameter changing process. When
30 the power is turned on with the key switch turned off, the parameter changing process is not performed and initialization at the start of a game is performed.

When the answer is "YES," a parameter update request command is transmitted to the sub control circuit 201 for executing the parameter changing process (S532). Then, it is determined whether the key switch is turned off or not (S533). When the answer is "NO," an initialization command is transmitted 5 (S537) to return to the main processing. When the answer is "YES," a key switch off command is transmitted to the sub control circuit 201 (S534) to finish the parameter changing process. When the answer is "NO," the process skips to S534. Then, it is determined whether or not a parameter changing completion command indicating the completion of the parameter changing process at the sub 10 control circuit 201 is received (S535). When the answer is "YES," rewiring of pay amounts or winning probabilities is executed based on the contents of the received command (S536). An initialization command is transmitted (S537) to return to the main flow. When the answer is "NO," a command reception is monitored in S535 because update is still performed.

15 Now the control operation of the sub CPU 203 in the sub control circuit 201 will be described.

FIG. 31 is a flowchart of interrupt process 1. The interrupt process 1 is executed every 3 ms. to store commands transmitted from the main control circuit 101 in the sub RAM 205.

20 First, the sub CPU 203 checks an input buffer (S600) to determine whether there is an input signal in the input buffer (S601). When the answer is "NO," the process is terminated. When the answer is "YES," a reception flag is tuned on (S602) and the contents of the received command are set in the RAM 205 (S603) to finish the process. Then, the received command is checked to 25 determine whether the received command is an initialization command or not (S604). When the answer is "YES," a used payout scheme setting and image data based on the scheme are checked (S605) to display images on the LCDs (S606) and the process is terminated. When the answer is "NO," the process is terminated.

30 FIG. 32 is a flowchart of the main processing in the sub control circuit 201. First, the sub CPU 203 checks a reception flag in the sub RAM 205 to

determine whether or not a parameter change request command is transmitted from the main control circuit 101 (S620). When the answer is "YES," the parameter changing process is executed (S621), and the process proceeds to S622. When the answer is "NO," S621 is skipped. In the parameter changing process, pay amounts and probabilities can be changed. The details will be described below.

Then, it is determined whether or not a start command is received (S622). When the answer is "YES," a starting display control process is executed (S622). In the starting display control process, a BR control process is performed during a BR. The details will be described below.

Then, it is determined whether or not a reel stop command is received (S624). When the answer is "NO," the process skips S625 and proceeds to S626. When the answer is "YES," a display control process at a reel stop is executed (S625). The display control process at a reel stop includes a BR occurrence determining process, a stop order instruction in a BR and displaying according to the degree of agreement between the contents of information and an actual stopping operation. The details will be described below.

Then, it is determined whether a 1-game termination command is received or not (S626). When the answer is "NO," the process skips S627 and returns to S620 to repeat the same processing. When the answer is "YES," a display control process at the end of a game is executed (S627). The display control process at the end of a game includes an informational display process and a process of updating the number of BR continuations when the game is in a BR round at that time. The details will be described below.

After the completion of S627, the process returns to S620 to repeat the same processing. In this manner, the main processing in the sub control circuit 201 includes separate displaying processes repeatedly executed on the basis of commands transmitted from the main control circuit 101.

FIG. 33 is a flowchart of the parameter changing process. First, the CPU 103 displays the support menu screen in FIG. 22A (S540). The support menu includes three modes to select one of the modes. The sub CPU 203

determines whether mode 1 is selected or not (S541). When the answer is "YES," a payout/probability changing process is executed (S542), and the process proceeds to S547. When the answer is "NO," it is determined whether mode 2 is selected or not (S543). When the answer is "YES," an ST occurrence probability changing process is performed (S544), and the process proceeds to S547. When the answer is "NO," it is determined whether mode 3 is selected or not (S545). When the answer is "YES," a setting changing process is performed (S546), and the process proceeds to S547. When the answer is "NO," no processing in any mode is executed, and the process proceeds to S547.

10 Then, it is determined whether or not the key switch is turned off, that is, whether or not a key switch off command is received from the main control circuit 101 (S547). When the answer is "YES," the pay amount data and probability data stored at that time are transmitted as a parameter change completion command to the main control circuit 101 (S548). The process quits the support menu and returns to initialization. When the answer is "NO," the process returns to S540 to repeat the same processing until a selection of any mode or an operation of the key switch is entered.

FIG. 35 is a flowchart of the payout/probability changing process. First, the CPU 103 displays the password input screen in FIG. 22B (S550). Then, it is determined whether or not there is an input of alphabets using the pseudo-keyboard displayed on the screen (S551). When the answer is "YES," the input alphabets are displayed on an input alphabet display area in FIG. 22B (turned, however) (S552), and the process returns to S551. When the answer is "NO," it is determined whether or not a key "CORRECT" in a right lower portion of the pseudo-keyboard is operated (S553). When the answer is "YES," the previously input alphabets are deleted (S554), and the process returns to S551.

When the answer is "NO" in S553, it is determined whether or not a key "END" in a right lower portion of the pseudo-keyboard is operated (S555). When the answer is "YES," it is determined whether or not the input and determined password is the correct password (S556). When the answer is "YES," an input process is executed (S557). When the answer is "NO" in S556, a

wrong password is input. The fact that the password is inappropriate is displayed (S559), and the process returns to S550 to prompt for reentry of a password.

When the answer is "NO" in S555, it is determined whether or not a key
5 "RETURN" in a right lower portion of the password input screen in FIG. 22B is operated (S558). When the answer is "YES," the process returns to S540, the starting step of the parameter changing process. When the answer is "NO," the process returns to S550.

FIG. 37 is a flowchart of the input process. First, the CPU 103 displays
10 the payout scheme setting screen A in FIG. 23 as an initialization screen (S560). Then, it is determined whether or not a screen switching button above the payout scheme setting screen is operated (S561). When the answer is "YES," a payout scheme setting screen according to the input operation is displayed (S562), and the process returns to S561. When the answer is "NO," it is determined whether
15 or not a decision button displayed in a left lower portion of the payout scheme setting screen is pressed (S563). When the answer is "YES," the payout scheme displayed at that time is stored and retained (S564), and the process returns to the payout/probability changing process. When the answer is "NO," the process returns to S561 to wait for the next input.

FIG. 38 is a flowchart of the starting display control process. First, the
20 sub CPU 203 executes the BR occurrence determining process (S660). In the BR occurrence determining process, it is determined whether or not to generate a battle rush as a special game. The details will be described below. Then, a BR execution process is executed (S680). In the BR execution process, stop order
25 information is given during a BR. The details will be described below.

FIG. 39 is a flowchart of the BR occurrence determining process. First,
the sub CPU 203 checks a BR flag stored in the sub RAM 205 to determine
whether a BR game is played or not at that time (S661). When the answer is
"YES," the process returns to the starting display control process. When the
30 answer is "NO," the table for determining BR occurrence and the number of BR continuations in FIG. 20 is referred to to determine whether any number of BR

continuations is selected or not (S662, 663). When the answer is "NO" (losing), the process returns to the starting display control process. When the answer is "YES," the BR flag in the sub RAM 205 is turned on to set the number of continuations selected in the BR continuation selection (S664). A BR
5 occurrence display is provided (S665), and the process returns to the starting display control process.

FIG. 40 is a flowchart of the BR execution process. First, the sub CPU 203 checks the BR flag and a BR save flag in the sub RAM 205 to determine whether or not a BR is played at that time or a BR is suspended with the
10 occurrence of a bonus game during the BR (S681). When the answer is "NO," a BR is not played and the process returns to the starting display control process. When the answer is "YES," a reception flag in the sub RAM 205 is checked to determine whether a bonus winning combination is internally selected or not (S682). When the answer is "YES," the BR is suspended and the BR flag in the
15 sub RAM 205 is turned off and the BR save flag is turned on (S683) to play the bonus game. The process returns to the starting display control process.

When the answer is "NO" in S682 and the BR is saved, the BR save flag in the sub RAM 205 is turned off and the BR flag is turned on to restart the BR (S684). Then, to check whether the BR has been continued predetermined times,
20 the number of the BR continuations in the sub RAM 205 is checked to determine whether the number of continuations becomes 0 or not (S685). When the answer is "YES," the BR should be ended. The BR flag is turned off (S686) and the process returns to the starting display control process.

When the answer is "NO," the BR game has not been played a specified
25 number of times. The reception flag in the sub RAM 205 is checked to determine whether or not "BELL" or "SB" is internally selected or not in the game (S687). When the answer is "YES," a selected stop table type stored in the reception flag in the sub RAM 205 is referred to to instruct an appropriate stop order (S688), and the process returns to the starting display control process.
30 When the answer is "NO," no information is given and the process returns to the starting display control process.

Now, a display control process with the stop buttons 15L, 15C and 15R operated in a BR will be described. FIG. 41 is a flowchart of a display control process at a reel stop. First, the sub CPU 203 checks the BR flag in the sub RAM 205 to determine whether a BR is played or not at that time (S700). When the answer is "NO," the process returns to the sub main processing. When the answer is "YES," a stop command in the reception flag in the sub RAM 205 is checked to compare stop order data and stopped reel data against a used table number data to determine whether or not the press order is the correct order specified in the stop table (S701). When the answer is "YES," the fact that the press order is correct (S702) is displayed. When the answer is "NO," the fact that the press order is wrong (S703) is displayed and the process returns to the sub main flow.

Now a display control process executed after all the reels 24L, 24C and 24R are stopped will be described. FIG. 42 is a flowchart of a display control process at the end of a game. First, the sub CPU 203 executes an informational display occurrence process to determine whether or not to generate an informational display of an internal winning combination (S720). If the game state at that time is a BR, a parameter update process for updating related parameters is executed (S740). When the generation of informational display is determined in the informational display occurrence process, the display control is executed (S760), and the process returns to the sub main process.

FIG. 43 is a flowchart of the informational display occurrence process. First, the sub CPU 203 checks the reception flag in the sub RAM 205 to determine whether or not the game state at that time is a normal game state (S721). When the answer is "YES," the informational display occurrence table in FIG. 21A is referred to to execute an informational display occurrence determination (S722). Then, it is determined whether there is a win or not (S723). When the answer is "YES," the display type selection table in FIG. 21B is referred to to execute a display mode determination process for determining the mode of informational display (S724). The process returns to the display control process at the end of a game. When the answer is "NO," the process

returns to the display control process at the end of a game.

FIG. 44 is a flowchart of the parameter update process. First, the sub CPU 203 checks the 1-game termination command in the reception flag stored in the sub RAM 205 to determine whether or not the game state at that time is a
5 bonus game (S741). When the answer is "YES, the game is not in a BR, and the process returns to the display control process at the end of a game. When the answer is "NO," the BR flag stored in the sub RAM 205 is checked to determine whether or not a BR game is played at that time (S742). When the answer is
10 "NO," the process returns to the display control process at the end of a game. When the answer is "YES," the value of a BR continuation counter in the sub RAM 205 is reduced (S743) and the process returns to the display control process at the end of a game.

The present embodiment has been described with the ST period as an advantageous state for a player. Instead, the above-described AT may be used,
15 or winning flags of other specific winning combination may be set or internal winning probabilities of winning combination may be increased for providing an advantageous state to a player.

In addition to the slot machine in the above-described embodiment, the present invention is also applicable to pachinko machines and arcade game
20 machines with electrical displays, and also to home video game machines which simulate the above-described functions by software.

The present invention is not restricted to the slot machine described above in which the reels stop by the stop button 15L through 15R being operated by the player. That is, the present invention is applicable to a slot machine for a
25 casino in which the reels stop automatically after being rotated for a prescribed period of time. While the slot machine adopting mechanical reels is explained in this embodiment, the present invention can also be applied to a video-type slot machine.

The present invention is not restricted to the slot machine
30 described above in which coins, medals and the like are used as gaming media. The present invention is also applicable to a gaming machine in which tokens or

cards are used as the gaming media.

Additional advantages and modifications will readily occur to those skilled in the art. Therefore, the invention in its broader aspects is not limited to the specific details and the representative embodiment shown and described
5 herein. Accordingly, various modifications may be made without departing from the spirit or scope of the general inventive concept as defined by the appended claims and their equivalents.

The claims defining the invention are as follows:

1. A gaming machine comprising:
variable display unit for variably displaying a plurality of symbols;
a selector for selecting a winning combination; and
5 an electrical display provided above the variable display unit.
2. A gaming machine as set forth in claim 1, further comprising a
translucent electrical display provided in front of the variable display unit.
- 10 3. A gaming machine as set forth in claim 1 or claim 2, further
comprising:
a game controller for generating a special game state which gives an
advantage to a player based on a predetermined condition; wherein,
the translucent electrical display executes shielding control for making at
15 least a part of the variable display unit invisible to the player during the special
game state, based on a prescribed condition.
4. A gaming machine as set forth in claim 1 through claim 3, wherein the
electrical display displays a pay table in which the winning combination is
20 associated with a predetermined prize to be awarded when the winning
combination is formed.
5. A gaming machine as set forth in claim 4, further comprising a switch
for switching the pay table to another table.
25
6. A gaming machine as set forth in claim 1 through claim 5, wherein the
electrical display displays an image for decorating the gaming machine.
7. A gaming machine as set forth in claim 3 through claim 6, wherein the
30 translucent electrical display displays an image according to a game state while
executing the shielding control.

8. A gaming machine as set forth in claim 3 through claim 7, wherein the translucent electrical display executes the shielding control to indicate an advantageous way of operating the gaming machine to the player.

5 9. A gaming machine substantially as herein described with reference to an embodiment as shown in the accompanying drawings.

DATED this nineteenth Day of November, 2003

Aruze Corporation

10

Patent Attorneys for the Applicant

SPRUSON & FERGUSON

FIG. 1

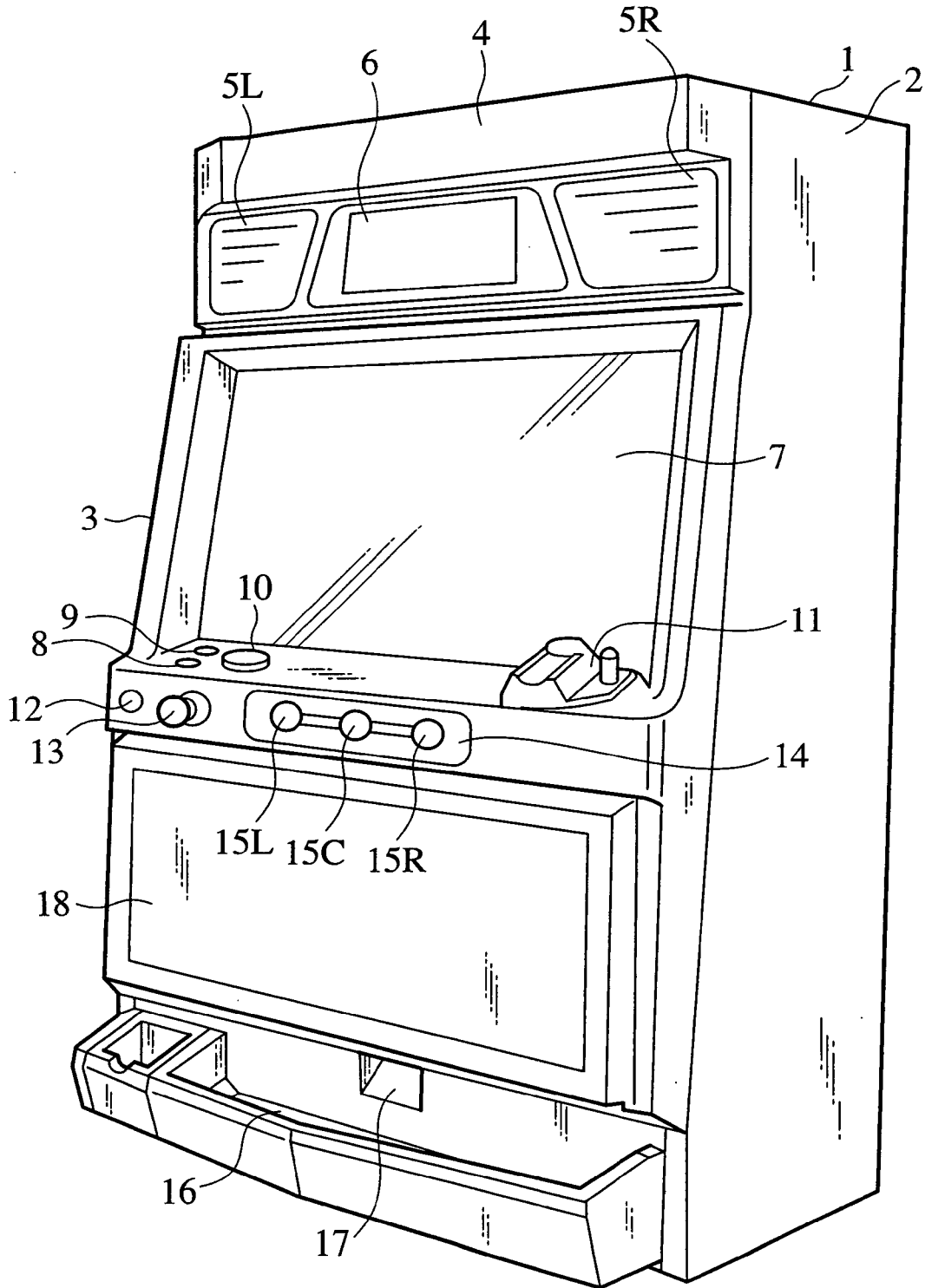

FIG.2

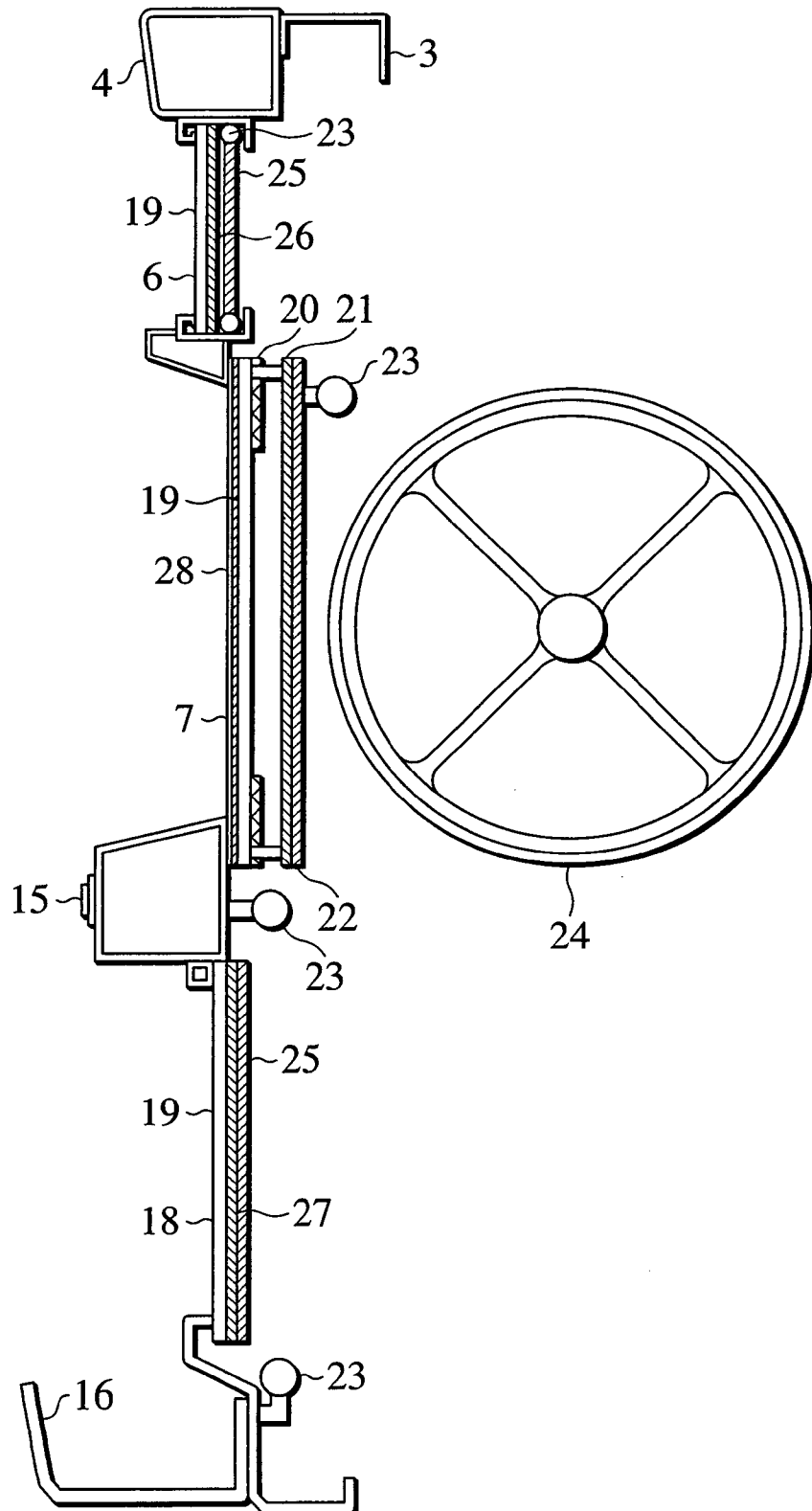

FIG.3

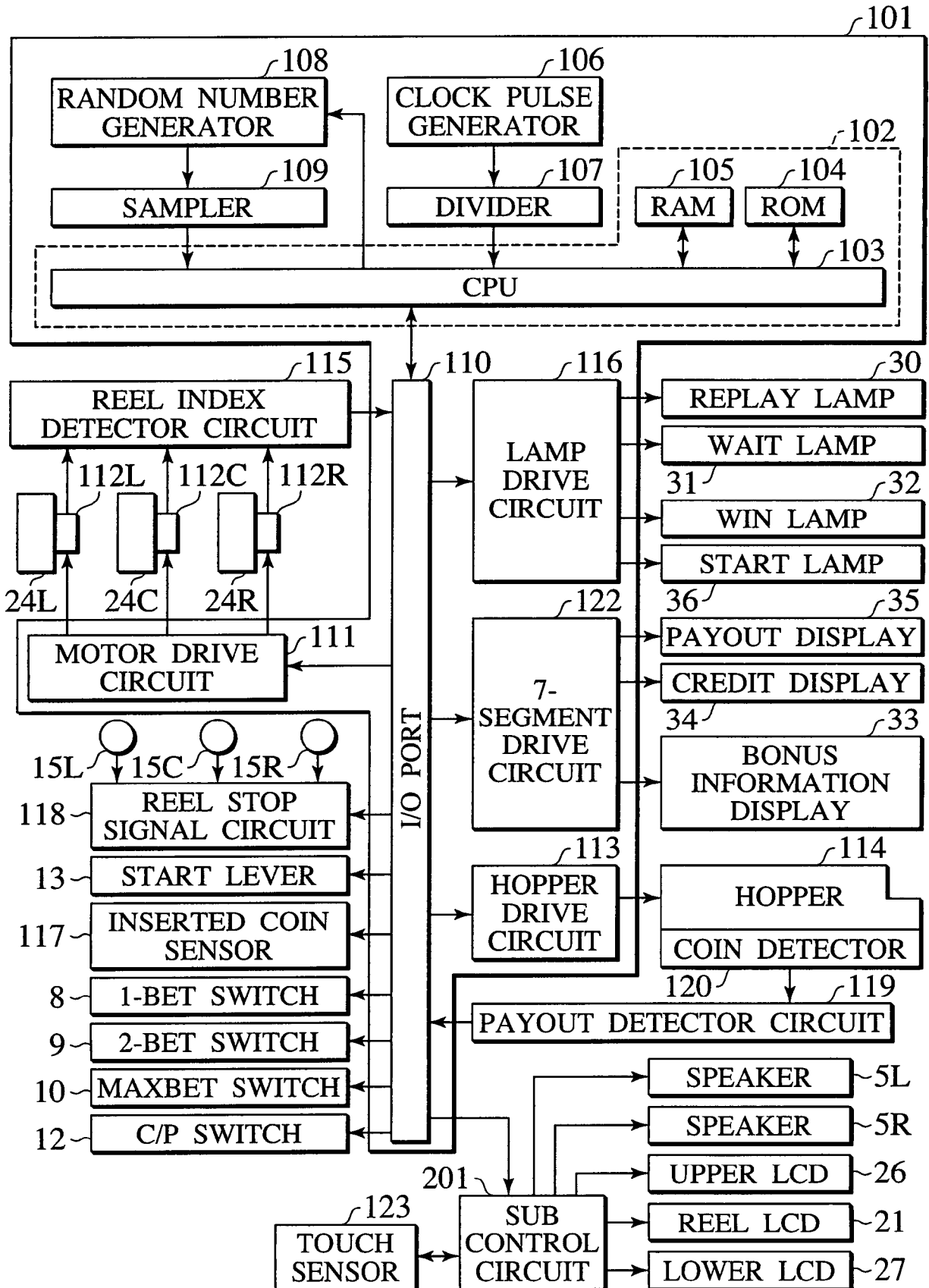

FIG.4

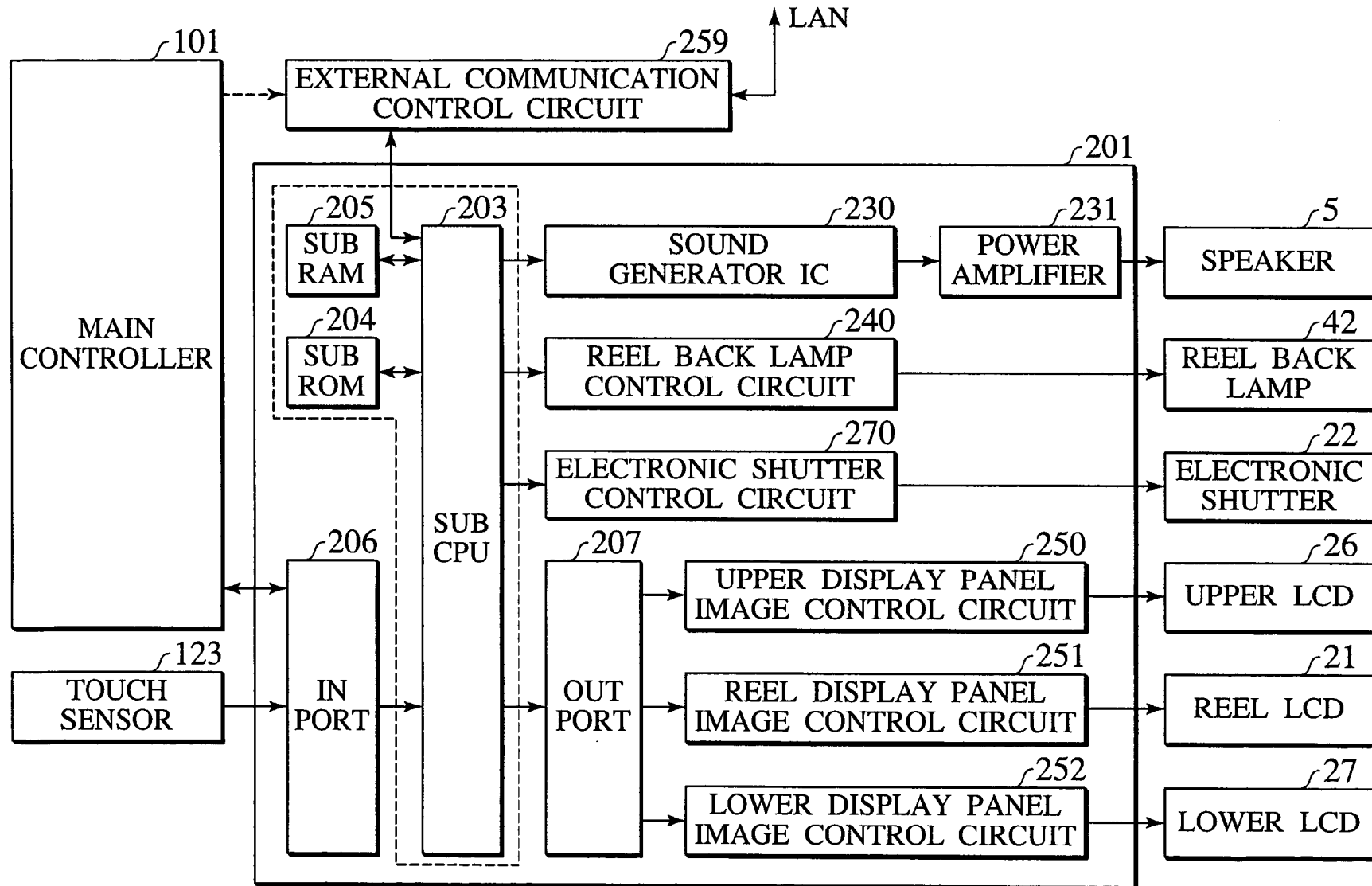

FIG.5

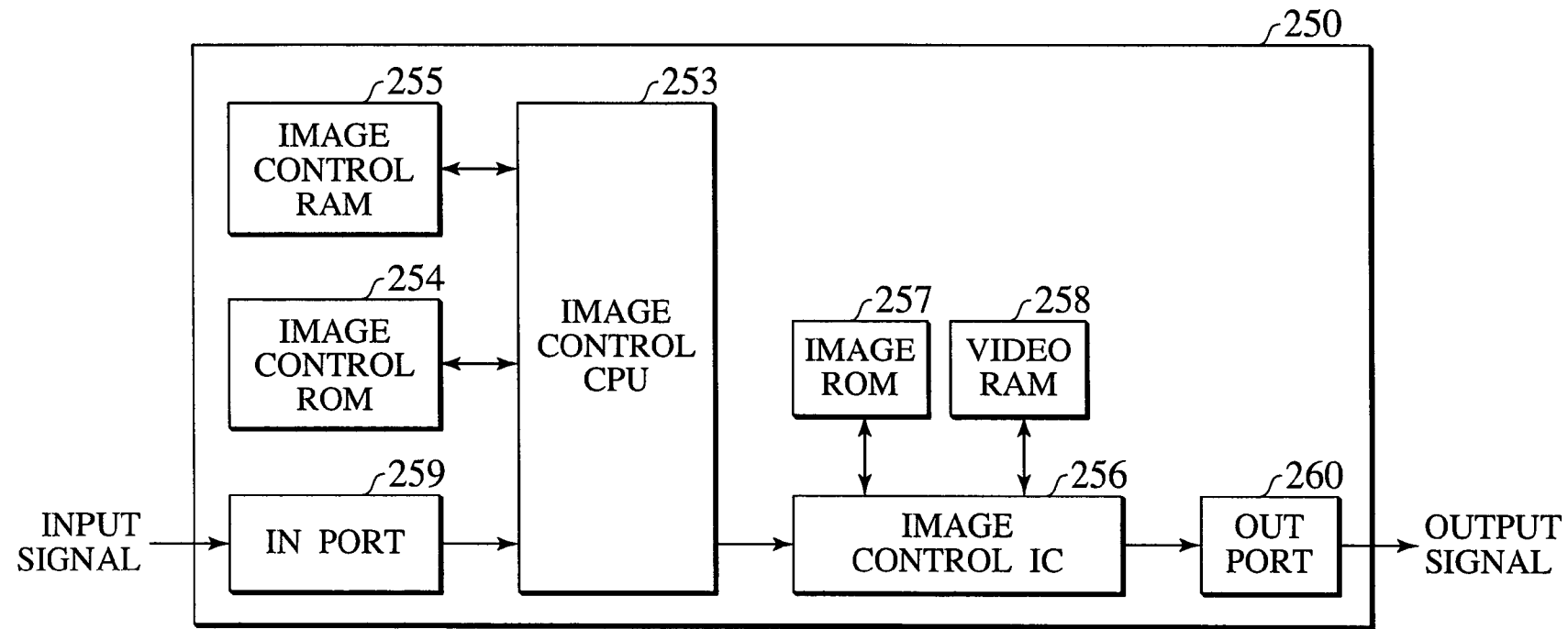

FIG. 6

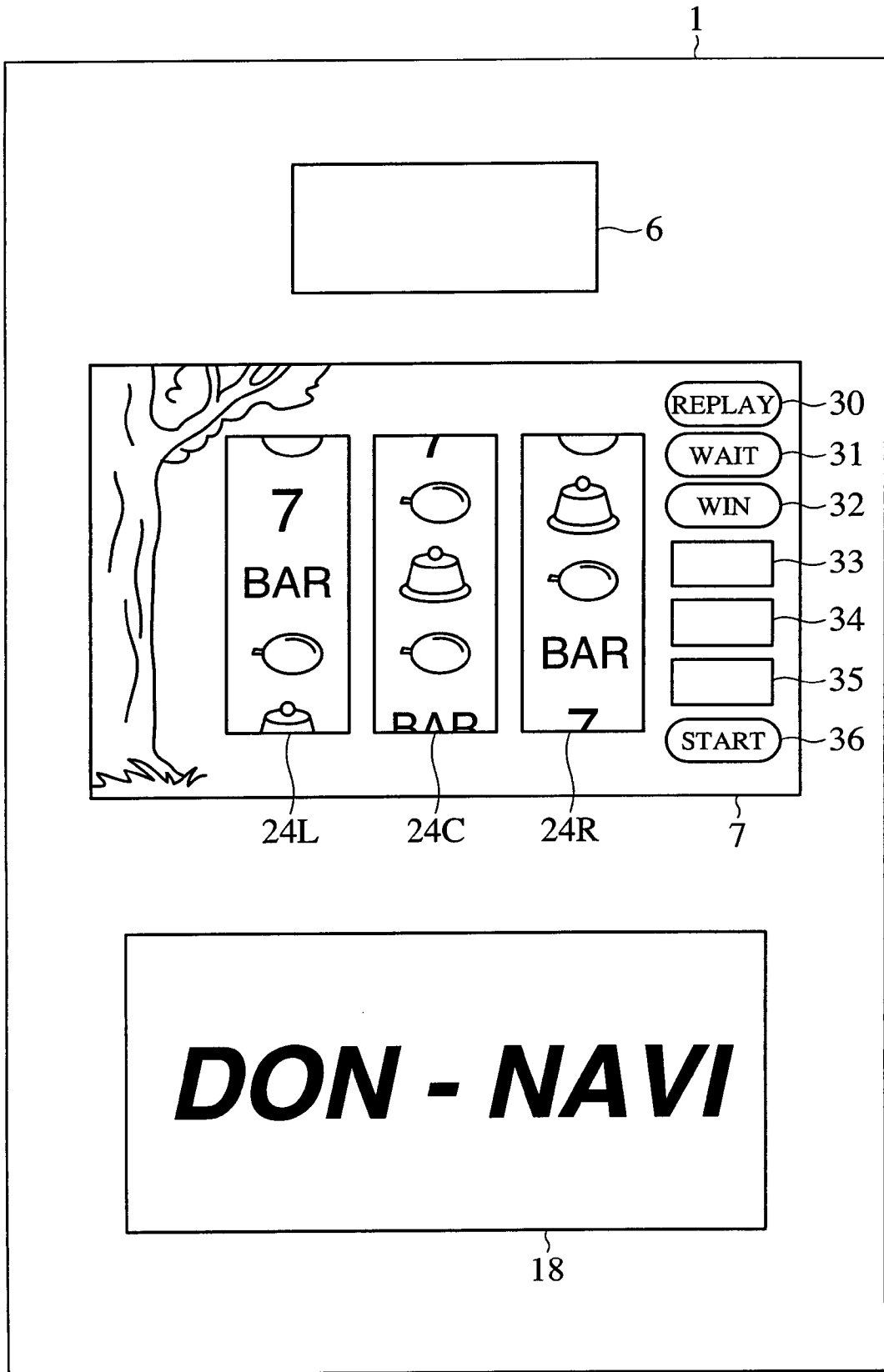

FIG. 7

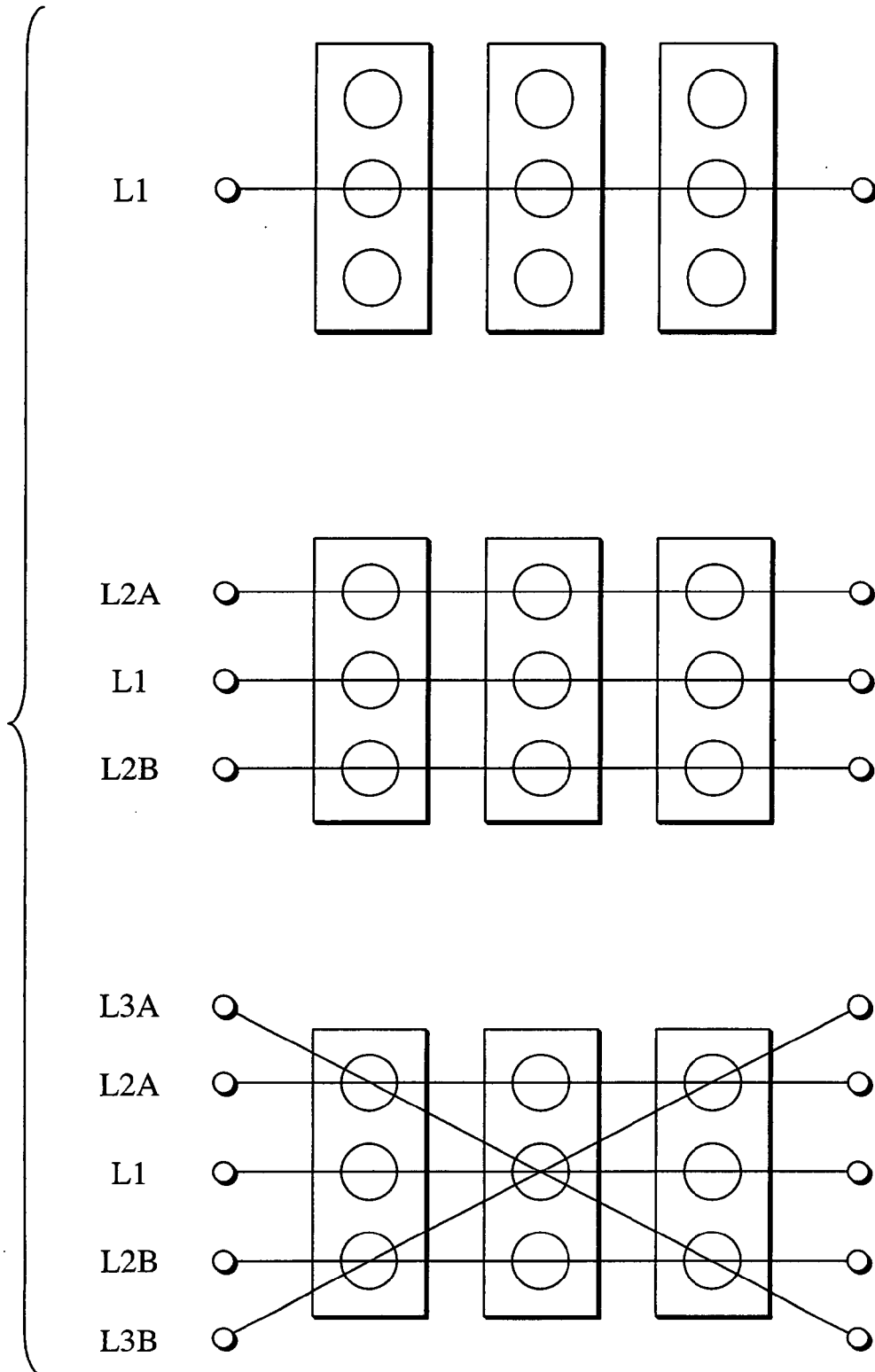

FIG. 8

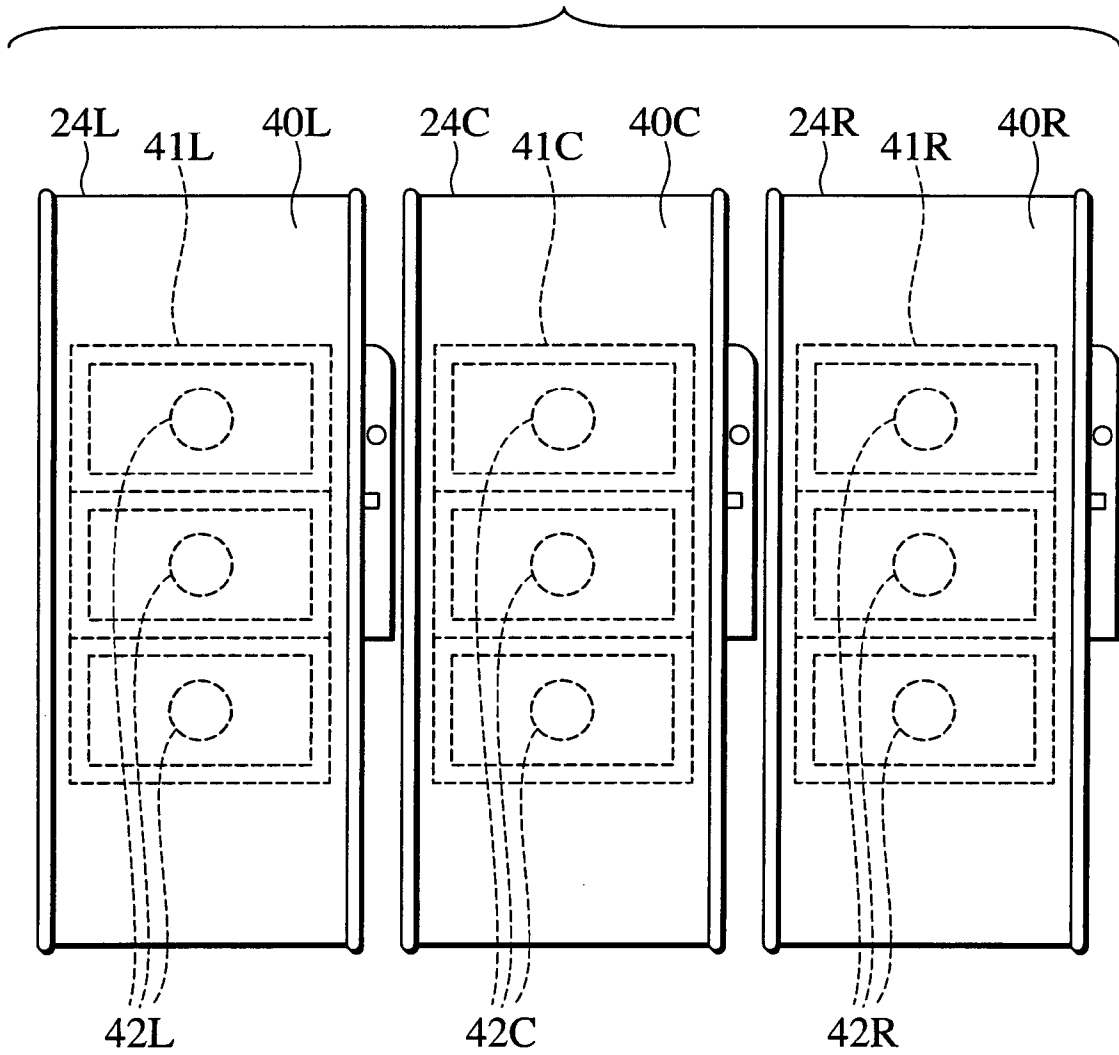

FIG.9

LEFT REEL		CENTER REEL		RIGHT REEL	
21	RED 7	21	RED 7	21	CHERRY
20	CHERRY	20	REPLAY	20	BELL
19	BELL	19	WATERMELON	19	REPLAY
18	REPLAY	18	SWORD 7	18	SWORD 7
17	RED 7	17	BELL	17	WATERMELON
16	BAR	16	SWORD 7	16	BELL
15	REPLAY	15	REPLAY	15	REPLAY
14	BELL	14	CHERRY	14	SWORD 7
13	SWORD 7	13	BELL	13	BAR
12	CHERRY	12	SWORD 7	12	BELL
11	BELL	11	REPLAY	11	REPLAY
10	REPLAY	10	WATERMELON	10	SWORD 7
9	BAR	9	BAR	9	WATERMELON
8	SWORD 7	8	BELL	8	REPLAY
7	BELL	7	RED 7	7	BELL
6	REPLAY	6	REPLAY	6	REPLAY
5	SWORD 7	5	BELL	5	BAR
4	WATERMELON	4	REPLAY	4	RED 7
3	BELL	3	BAR	3	BELL
2	REPLAY	2	SWORD 7	2	REPLAY
1	SWORD 7	1	BELL	1	SWORD 7
	40L'		40C'		40R'

FIG.10

WINNING COMBINATION	NORMAL GAME BONUS INTERNAL WINNING	NORMAL GAME DURING BB	JAC GAME
RED7-RED7-RED7	15 + BB		
BAR-BAR-BAR	15 + RB		
SWORD7-SWORD7-SWORD7	15 + SB		
WATERMELON-WATERMELON-WATERMELON	3	15	
BELL-BELL-BELL	6	7	
CHERRY-ANY-ANY	1	1	
REPLAY-REPLAY-REPLAY	REPLAY	1 + RB	15

FIG.11

TABLE NO.	L-C-R	L-R-C	C-L-R	C-R-L	R-L-C	R-C-L
1	○	×	×	×	×	×
2	×	○	×	×	×	×
3	×	×	○	×	×	×
4	×	×	×	○	×	×
5	×	×	×	×	○	×
6	×	×	×	×	×	○

○ ... WINNING

×

* SEEING AND PUSHING TIMING UNRELATED

FIG.12

WINNING COMBINATION	RANDOM NUMBER RANGE	WINNING PROBABILITY
SB	0 - 2298	2299 / 16384
BELL	22990 - 011024	8726 / 16384
WATERMELON	11025 - 11165	141 / 16384
CHERRY	11166 - 11385	220 / 16384
REPLAY	11386 - 13630	2245 / 16384
BB	13631 - 13668	38 / 16384
RB	13669 - 13696	27 / 16384
REPLAY	13697 - 16383	2686 / 16384

RANDOM NUMBER RANGE : 0 - 16383

FIG.13

START COMMAND		REEL STOP COMMAND		1-GAME TERMINATION COMMAND			
1	INTERNAL WINNING COMBINATION	1	STOPPING ORDER	1	WINNING TYPE		
	SB		FIRST STOP		SB		
	BELL		SECOND STOP		BELL		
	WATERMELON		THIRD STOP		WATERMELON		
	2		CHERRY			CHERRY	
			REPLAY			REPLAY	
			BB			BB	
			RB			RB	
	LOSS		LOSS				
3	GAME STATE	3	STOPPED REEL	3	BONUS GAME STATE		
	NORMAL GAME		LEFT REEL		NORMAL GAME 1 IN BB		
	RB INTERNAL WINNING		CENTER REEL		NORMAL GAME 2 IN BB		
	BB INTERNAL WINNING		RIGHT REEL		NORMAL GAME 3 IN BB		
	4		RB ROUND			RB GAME 1	
			BB ROUND			RB GAME 2	
						RB GAME 3	
			RB END				
		BB END					
5	SELECTED STOP TABLE	5	STOPPED POSITION	PARAMETER CHANGE COMMAND			
	TABLE NO.1		6	0 - 21	1	CHANGE REQUEST	
	TABLE NO.2					KEY SWITCH OFF COMMAND	
	TABLE NO.3				1	KEY SWITCH OFF	
	TABLE NO.4					INITIALIZATION COMMAND	
	TABLE NO.5					1	INITIALIZATION REQUEST
	TABLE NO.6						

FIG.14A

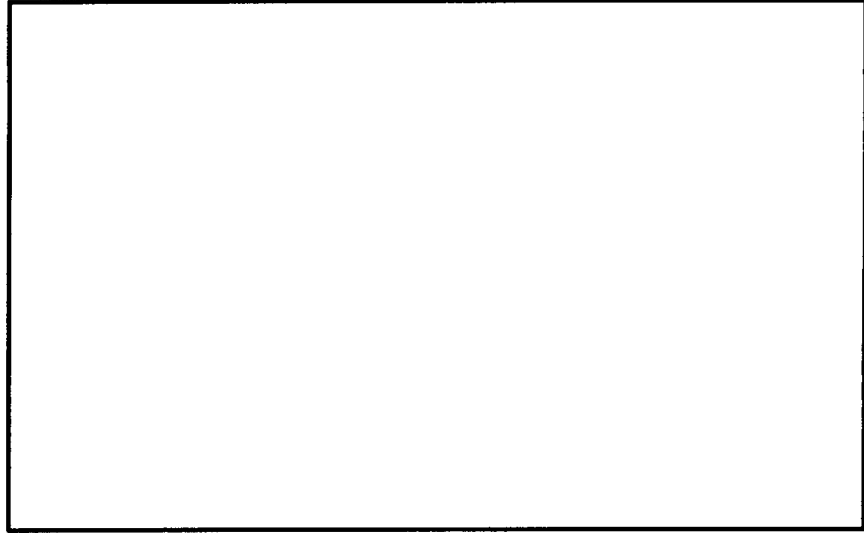

FIG.14B



FIG.14C

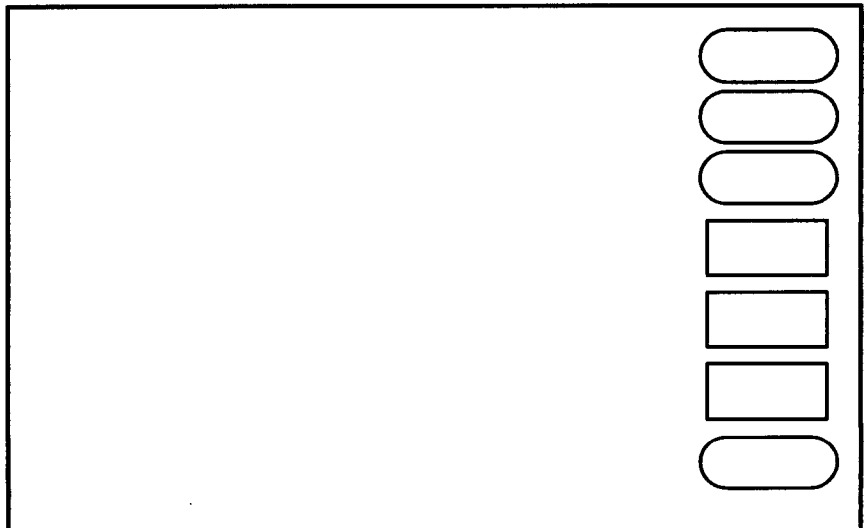

FIG.15



FIG.16A

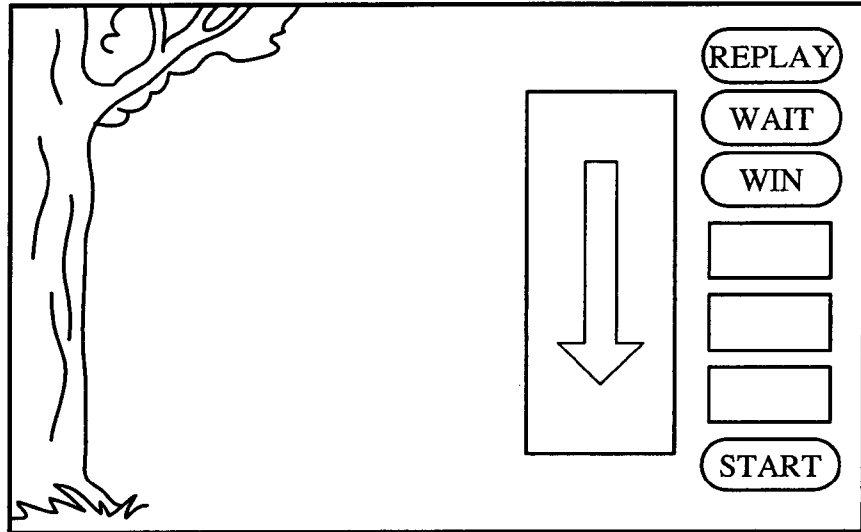

FIG.16B

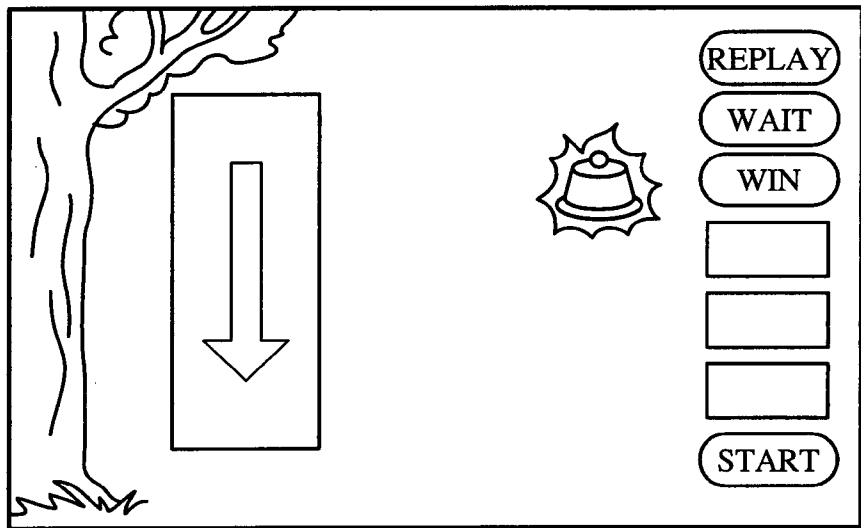

FIG.16C

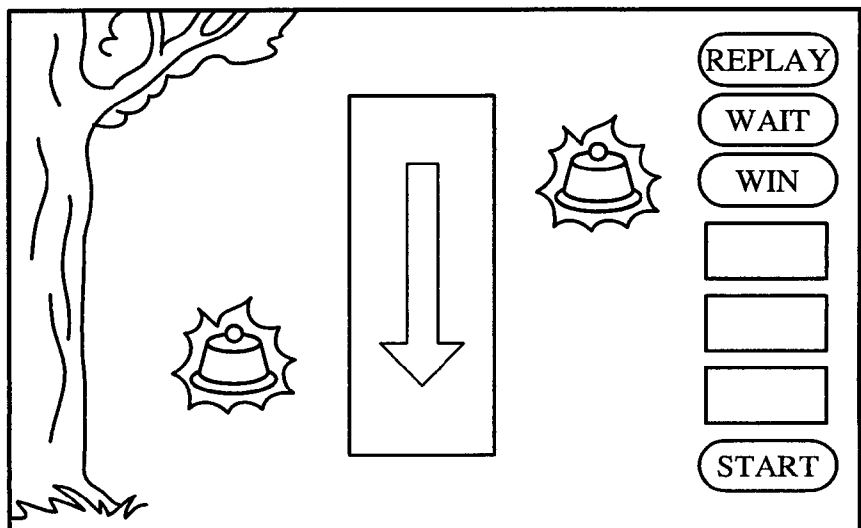

FIG.17A

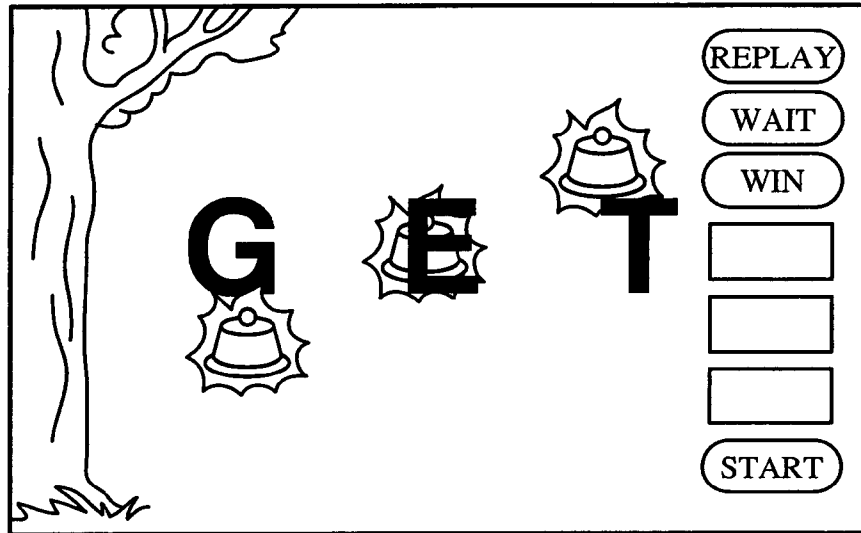

FIG.17B

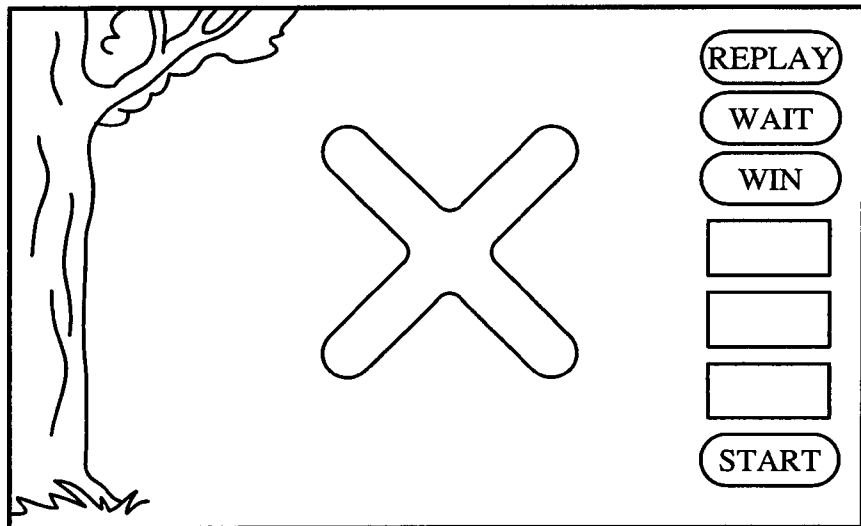

FIG.17C

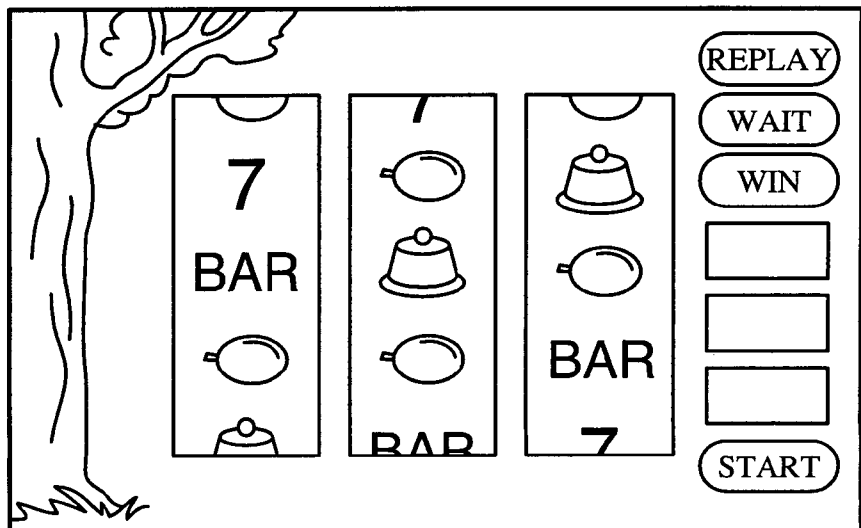

FIG.18A

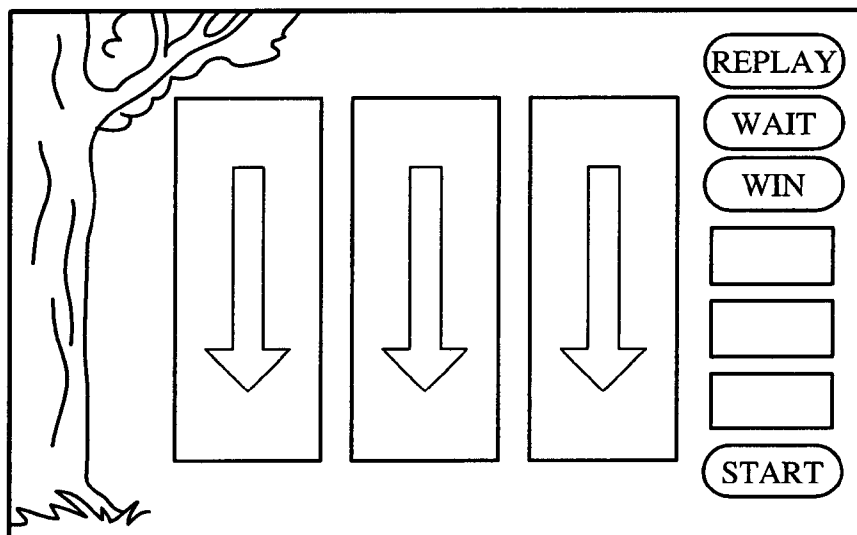

FIG.18B

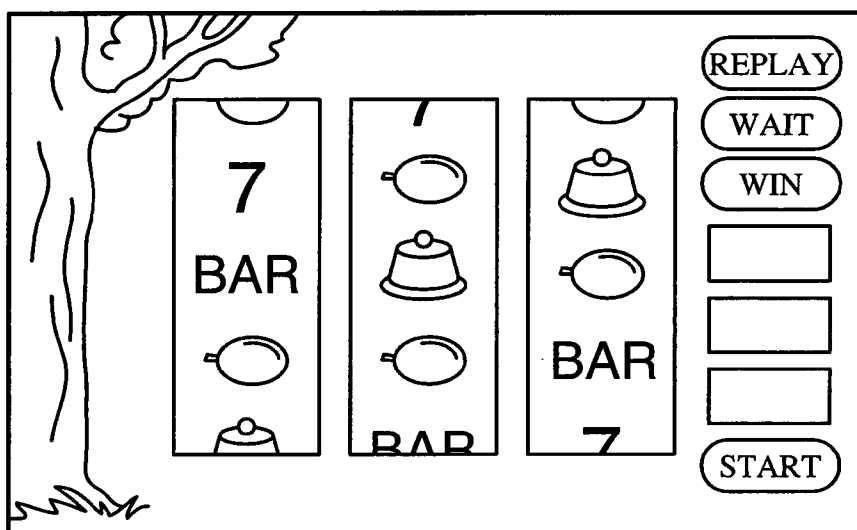

FIG.18C

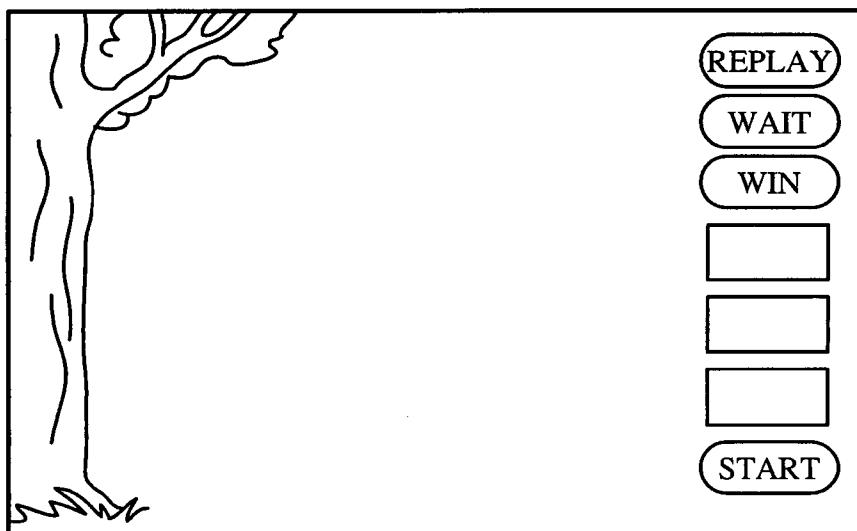

FIG.19A

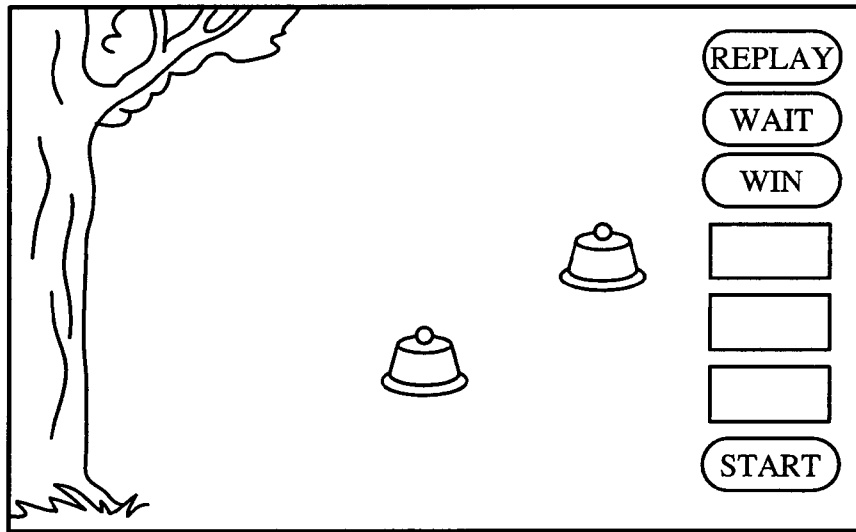

FIG.19B

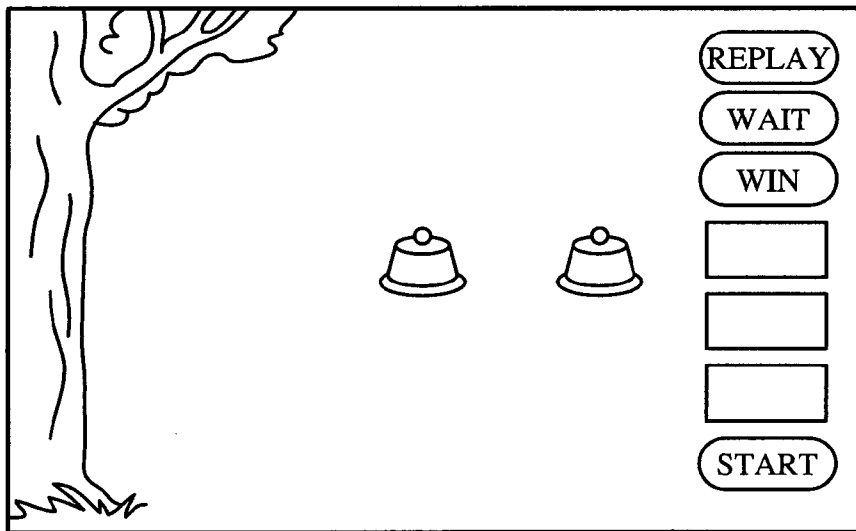

FIG.20

SET FLAG	THE NUMBER OF BR CONTINUATIONS			
	10 GAMES	50 GAMES	100 GAMES	LOSS
WATERMELON	0 - 10	11 - 13	14 - 15	16 - 127
2 CHERRYS	0 - 6	7 - 10	-	11 - 127
LOSS	0 - 14	-	15 - 24	25 - 127

RANDOM NUMBER RANGE : 0 - 127

FIG.21A

WINNING TYPE	WINNING KIND			
	BB	RB	WATER-MELON	SB
WIN	0 - 45	0 - 56	0 - 20	0 - 11
LOSS	46 - 127	57 - 127	21 - 127	12 - 127

RANDOM NUMBER RANGE : 0 - 127

FIG.21B

THE NUMBER OF BELL IMAGES	WINNING KIND			
	BB	RB	WATER-MELON	SB
ALL	0 - 84	0 - 96	0 - 20	0 - 8
APPEARANCE - 1	85 - 121	97 - 127	21 - 52	9 - 21
APPEARANCE - 2	122 - 127	-	53 - 90	22 - 38
APPEARANCE - 3	-	-	91 - 116	39 - 95
APPEARANCE - 4	-	-	117 - 123	96 - 120
APPEARANCE - 5	-	-	124 - 127	121 - 127

RANDOM NUMBER RANGE : 0 - 127

FIG.22A

SELECT MODE

MODE 1
(PAY AMOUNT AND WINNING PROBABILITY CHANGE)

MODE 2
(ST OCCURRENCE PROBABILITY CHANGE)

MODE 3
(SETTING CHANGE)

KEY SWITCH OFF → END

FIG.22B

ENTER PASSWORD

>*****■

A	B	C	D	E	F	G
H	I	J	K	L	M	N
O	P	Q	R	S	T	U
V	W	X	Y	Z	CORRECT	END

RETURN

FIG.23

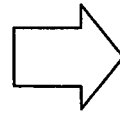

A

WINNING COMBINATION	NORMAL GAME		NORMAL GAME IN BB	
	PAY AMOUNT	INTERNAL WINNING PROBABILITY	PAY AMOUNT	INTERNAL WINNING PROBABILITY
RED7-RED7-RED7	15 + BB	38 / 16384	-	-
BAR-BAR-BAR	15 + RB	27 / 16384	-	-
SWORD7-SWORD7-SWORD7	15 + SB	2299 / 16384	-	-
WATERMELON-WATERMELON-WATERMELON	3	141 / 16384	15	2100 / 16384
BELL-BELL-BELL	6	8726 / 16384	7	7080 / 16384
CHERRY-ANY-ANY	1	220 / 16384	1	230 / 16384
REPLAY-REPLAY-REPLAY	REPLAY	2245 / 16384	1 + (3)	5400 / 16384
LOSS		2686 / 16384		1574 / 16384

DECISION

FIG.24

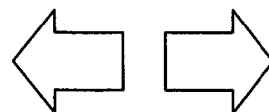

B

WINNING COMBINATION	NORMAL GAME		NORMAL GAME IN BB	
	PAY AMOUNT	INTERNAL WINNING PROBABILITY	PAY AMOUNT	INTERNAL WINNING PROBABILITY
RED7-RED7-RED7	15 + BB	38 / 16384	-	-
BAR-BAR-BAR	15 + RB	27 / 16384	-	-
SWORD7-SWORD7-SWORD7	15 + SB	2299 / 16384	-	-
WATERMELON-WATERMELON-WATERMELON	15	356 / 16384	15	2100 / 16384
BELL-BELL-BELL	6	7688 / 16384	7	7080 / 16384
CHERRY-ANY-ANY	2	892 / 16384	1	230 / 16384
REPLAY-REPLAY-REPLAY	REPLAY	2245 / 16384	1 + (3)	5400 / 16384
LOSS		2837 / 16384		1574 / 16384

DECISION

FIG.25

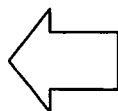

c

WINNING COMBINATION	NORMAL GAME		NORMAL GAME IN BB	
	PAY AMOUNT	INTERNAL WINNING PROBABILITY	PAY AMOUNT	INTERNAL WINNING PROBABILITY
RED7-RED7-RED7	15 + BB	51 / 16384		-
BAR-BAR-BAR	15 + RB	38 / 16384		-
SWORD7-SWORD7-SWORD7	15 + SB	1238 / 16384		-
WATERMELON-WATERMELON-WATERMELON	15	152 / 16384	3	3841 / 16384
BELL-BELL-BELL	6	8726 / 16384	3	6046 / 16384
CHERRY-ANY-ANY	2	220 / 16384	1	210 / 16384
REPLAY-REPLAY-REPLAY	REPLAY	2245 / 16384	1 + RB (2)	1524 / 16384
LOSS				4763 / 16384

DECISION

25/40

FIG.26A











7	7	7	15 + BIG BONUS
BAR	BAR	BAR	15 + REG BONUS
7	7	7	15 + REG BONUS
			3 (IN BB : 15)
			6 (IN BB : 7)
	—	—	1
			REPLAY (IN BB : +RB)

FIG.26B











7	7	7	15 + BIG BONUS
BAR	BAR	BAR	15 + REG BONUS
7	7	7	15 + REG BONUS
			15 (IN BB : 15)
			6 (IN BB : 7)
	—	—	2 (IN BB : 1)
			REPLAY (IN BB : +RB)

FIG.27

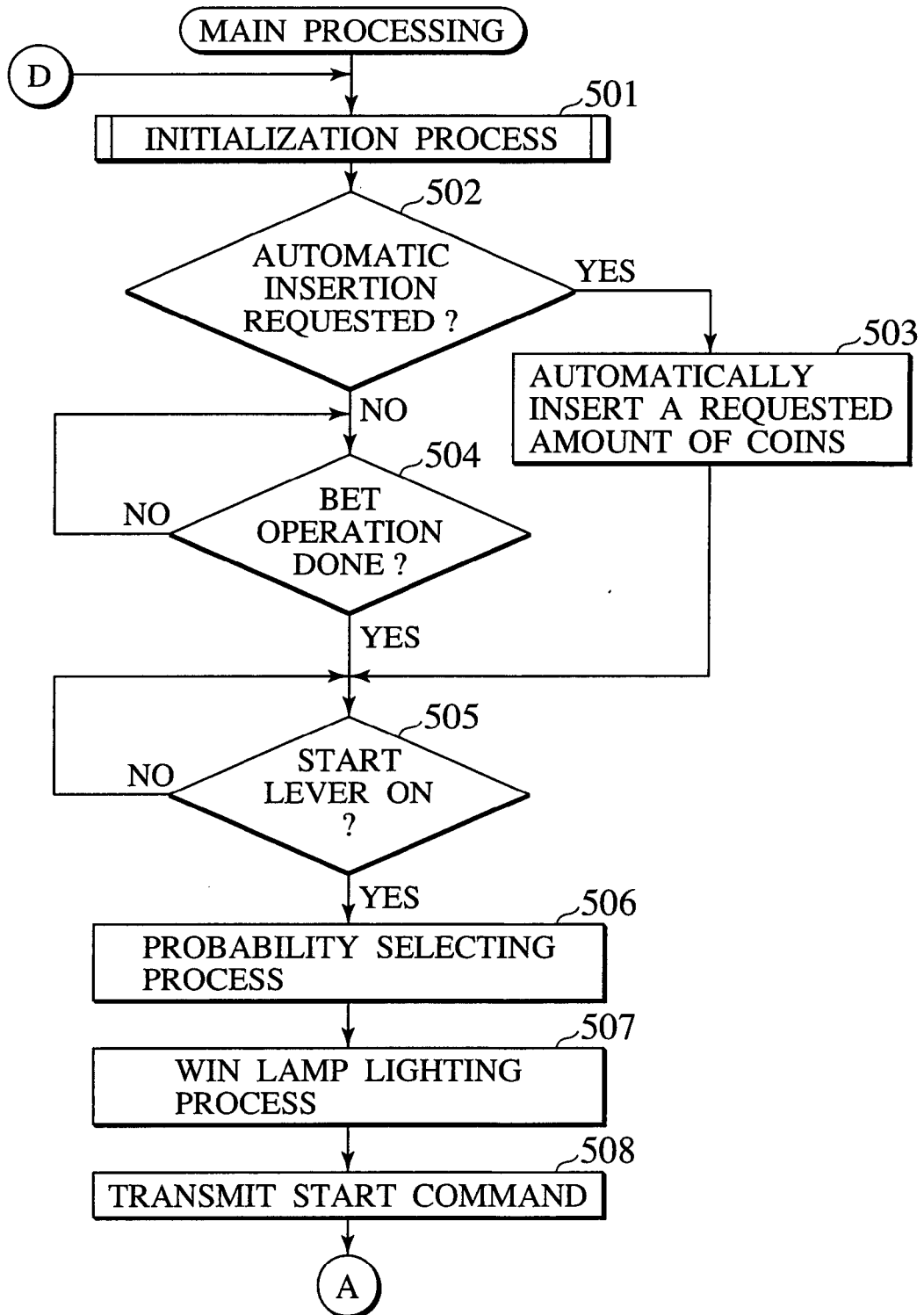

FIG.28

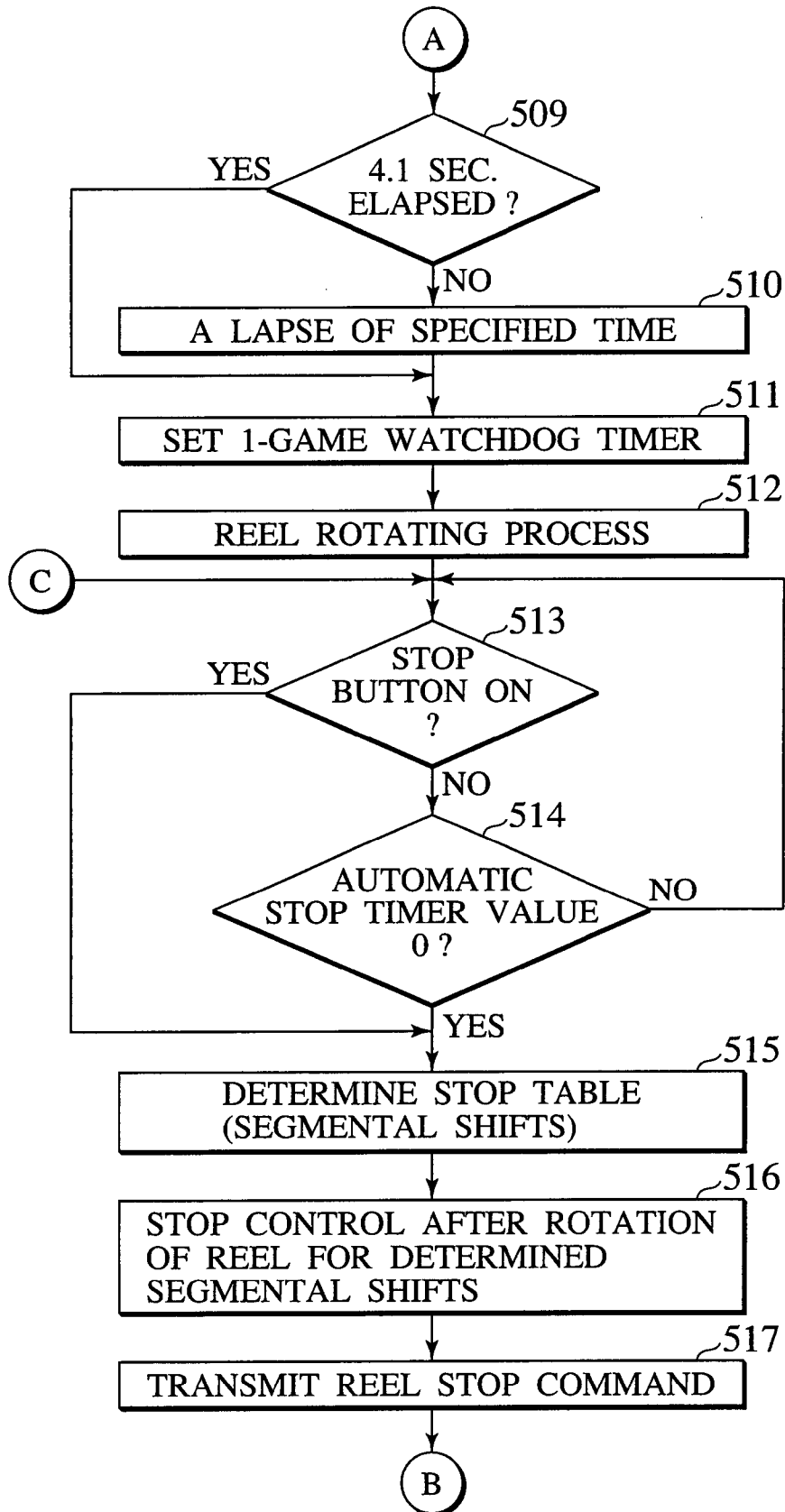

FIG.29

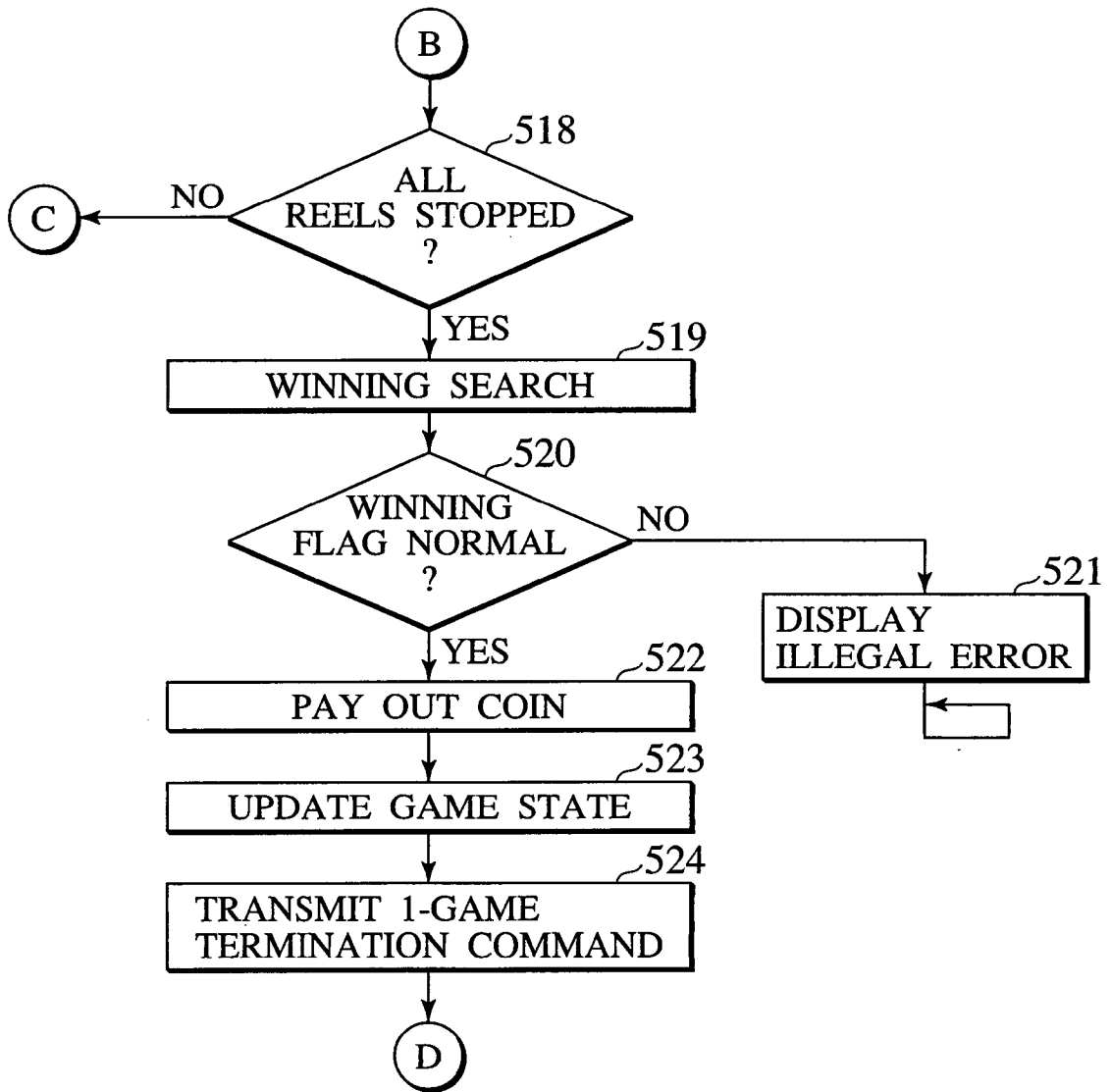

FIG.30

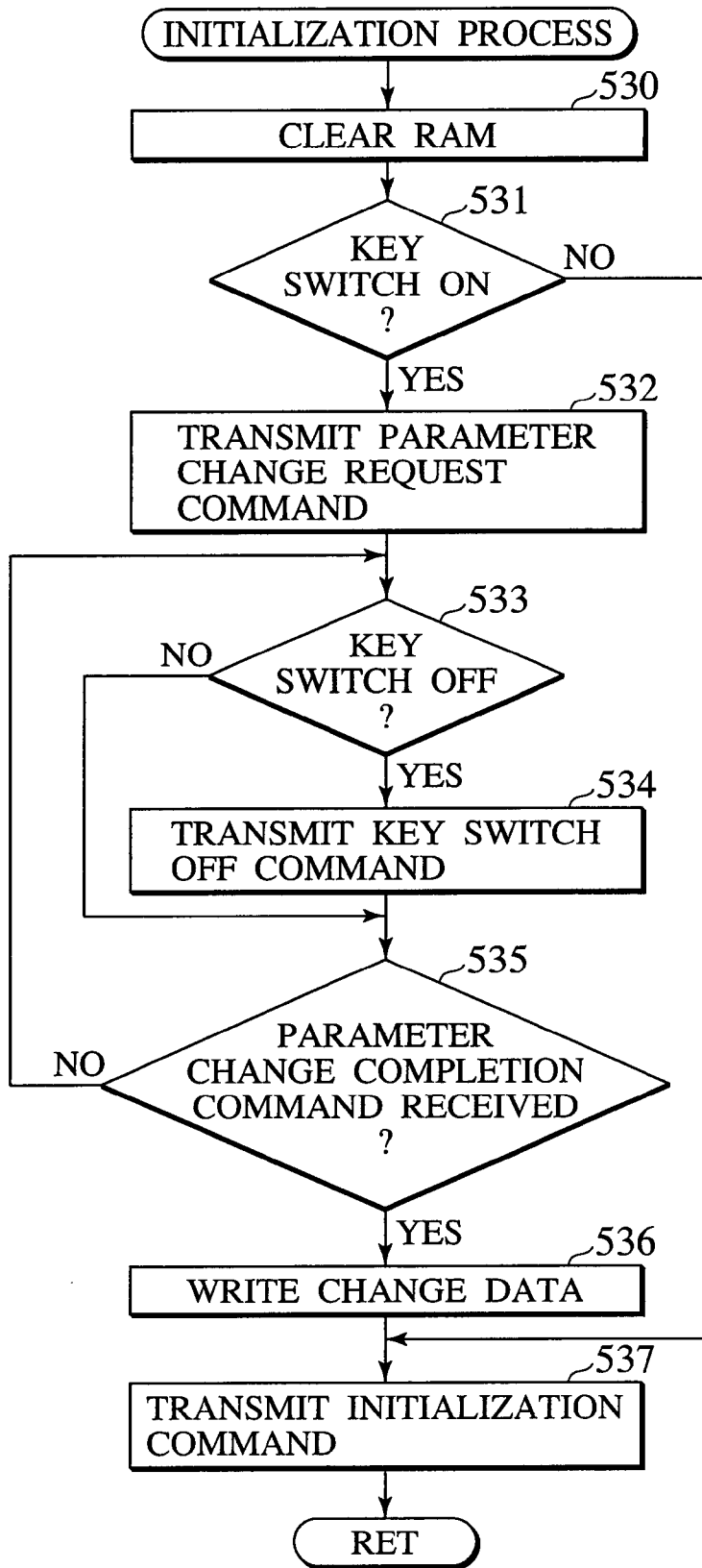

FIG.31

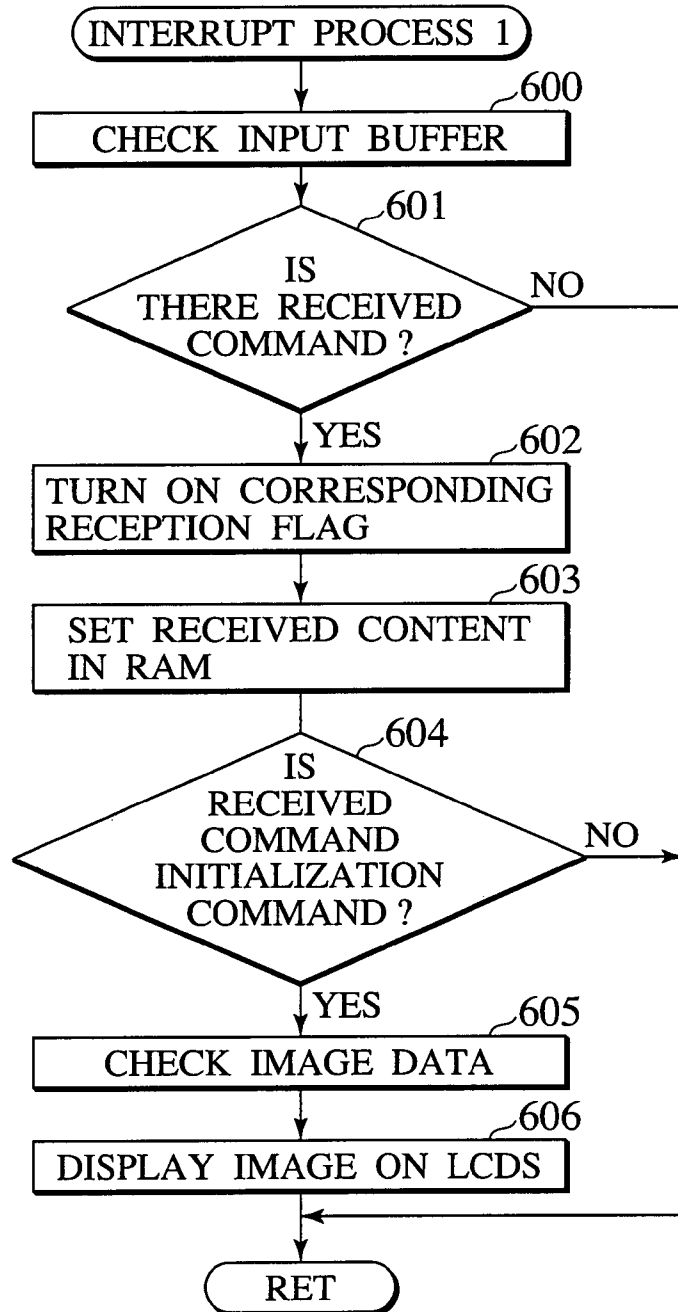

FIG.32

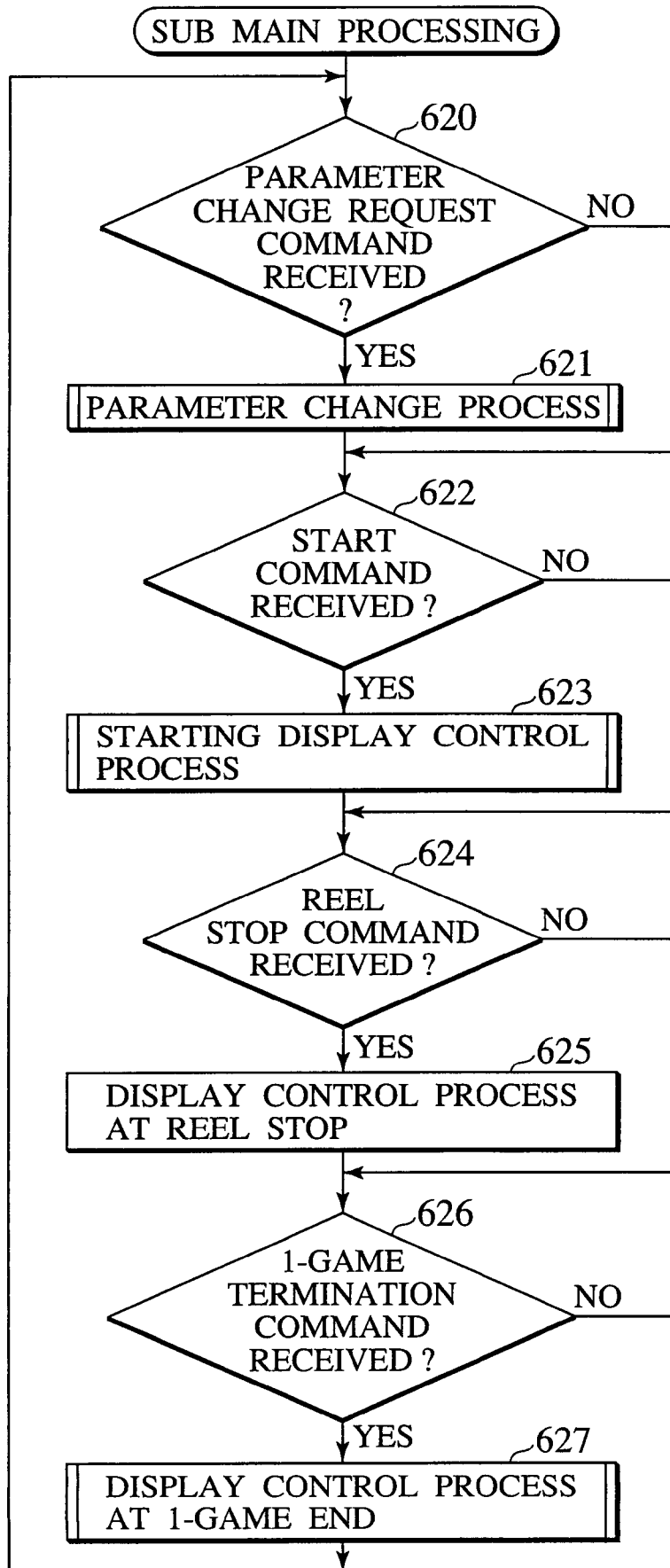

FIG.33

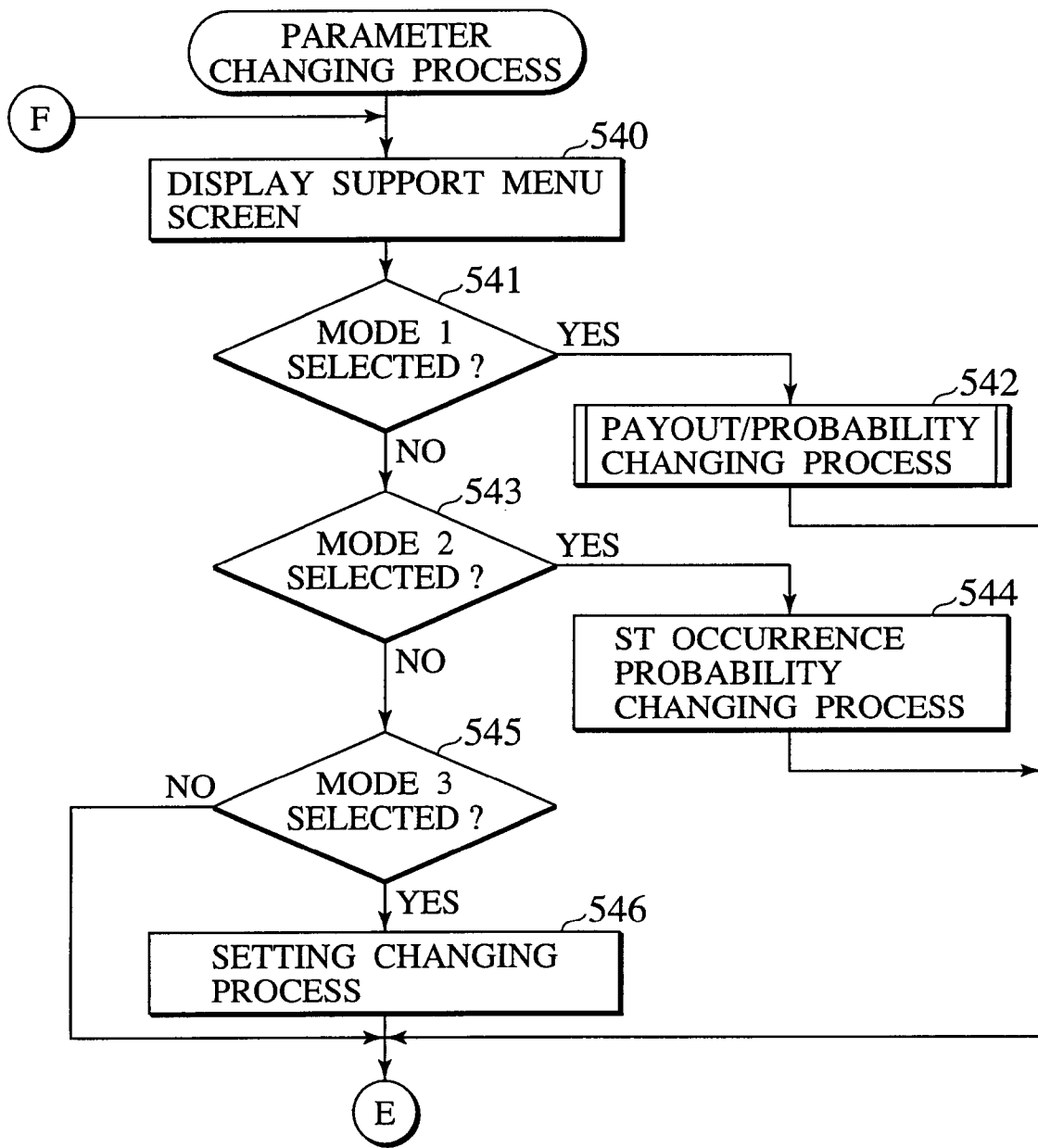

FIG.34

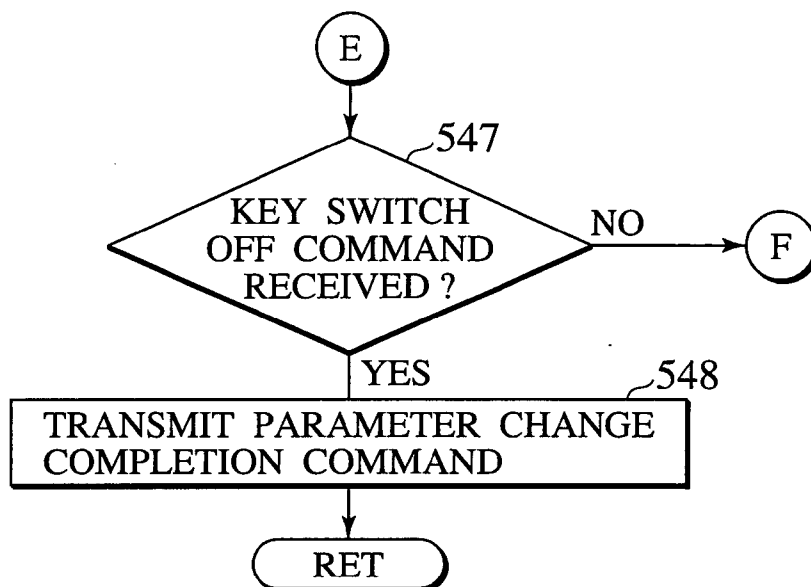

FIG.35

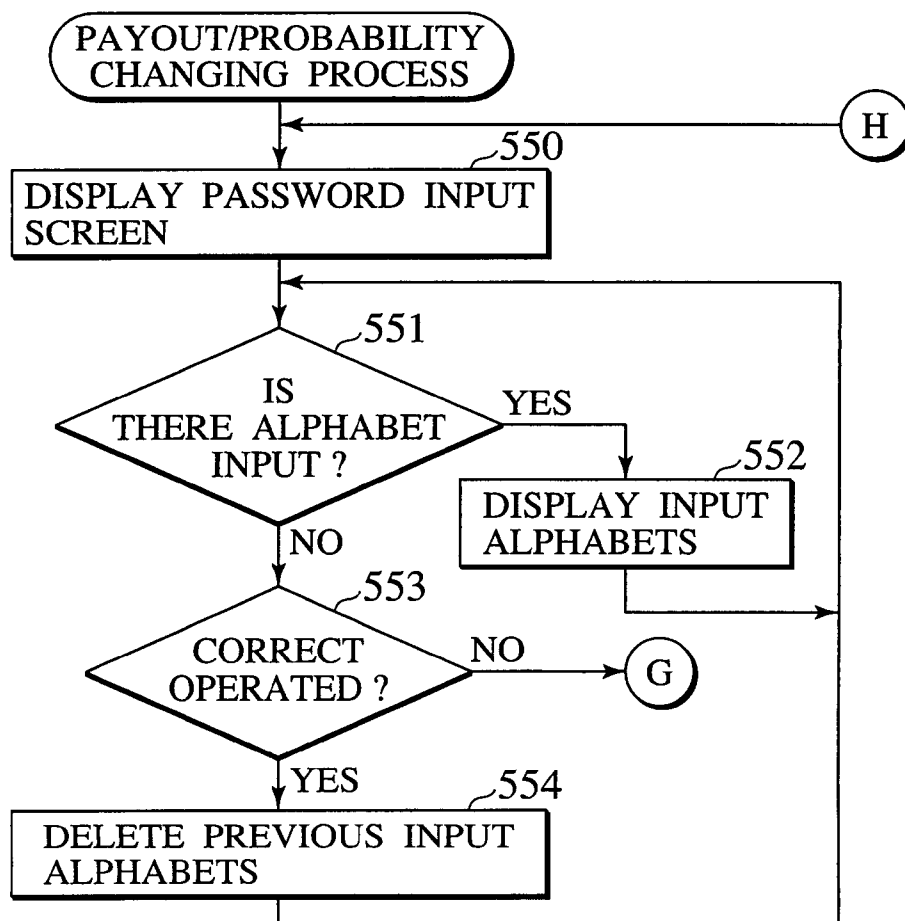

FIG.36

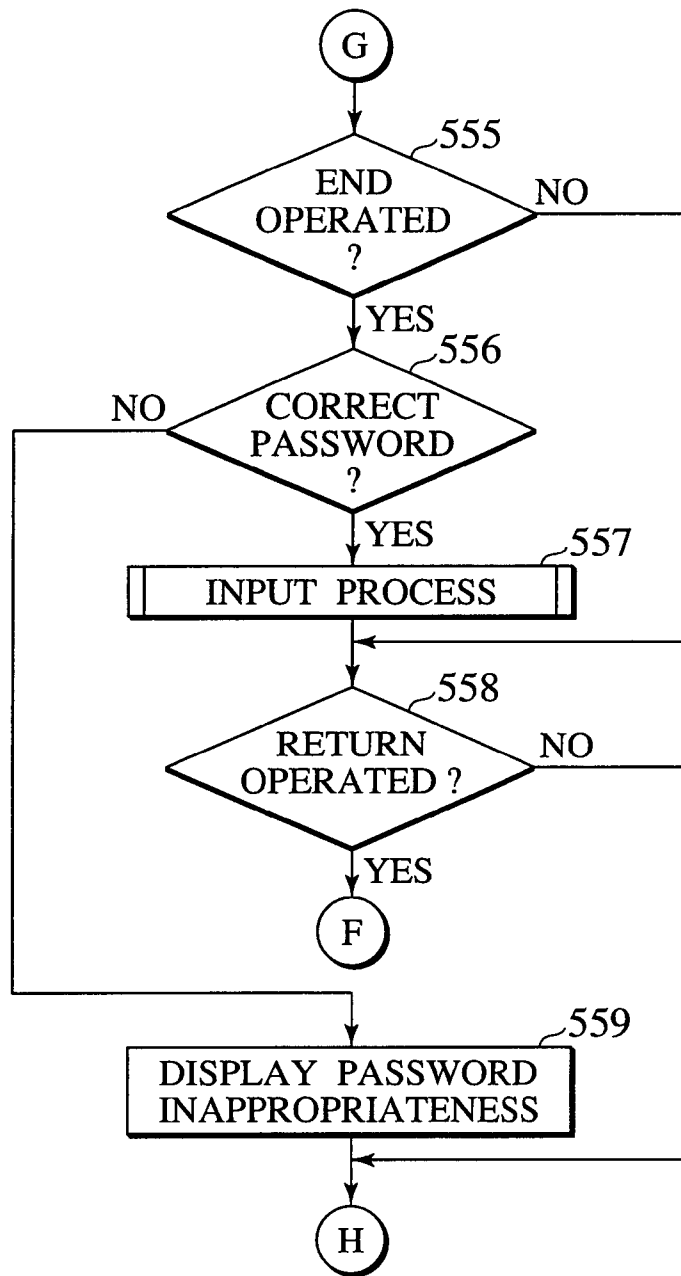

FIG.37

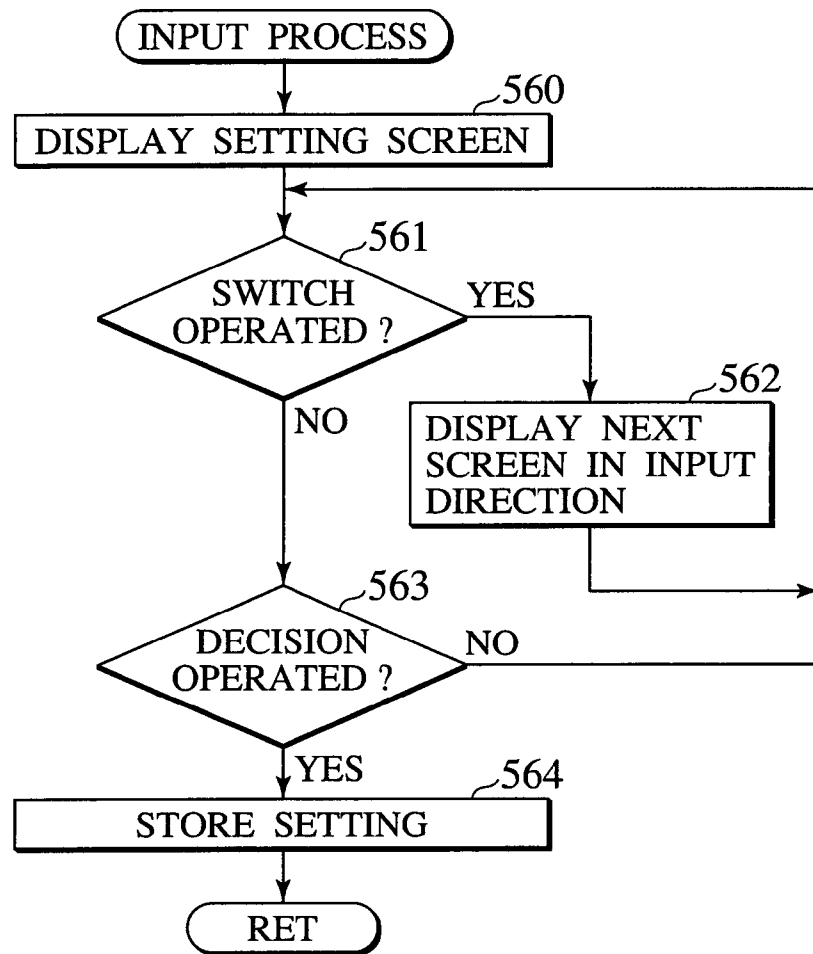

FIG.38

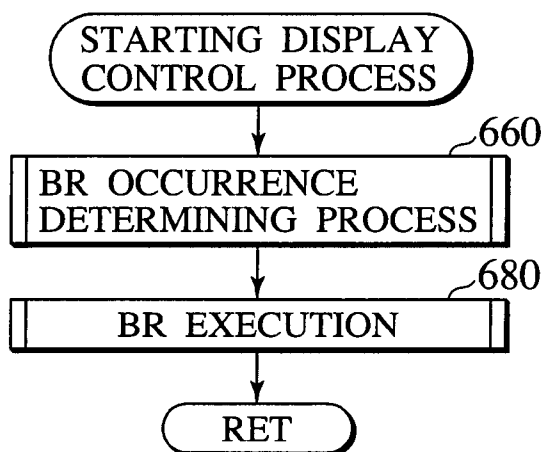

FIG39

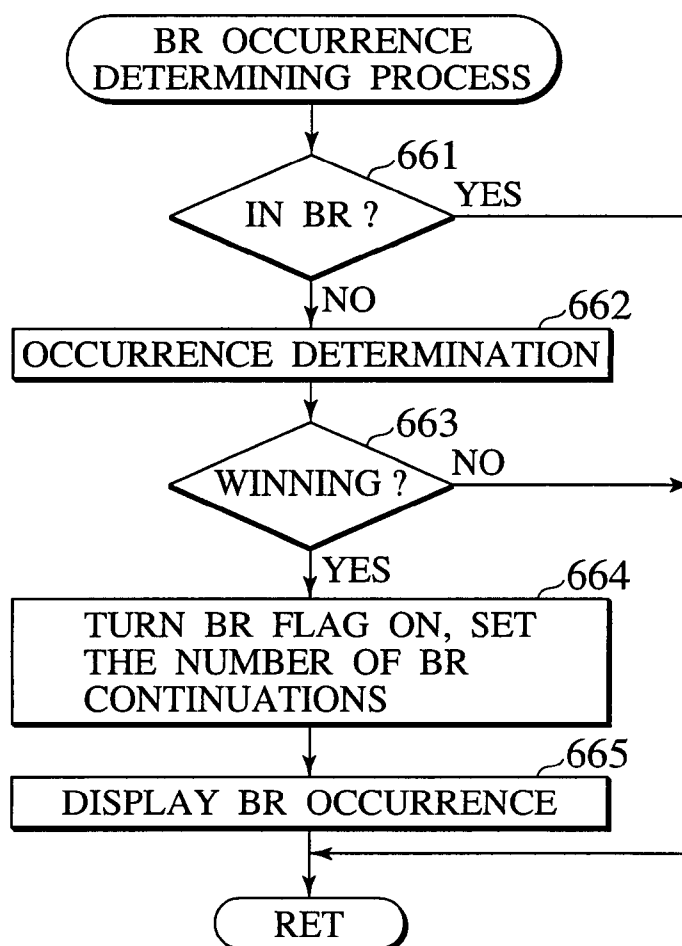

FIG.40

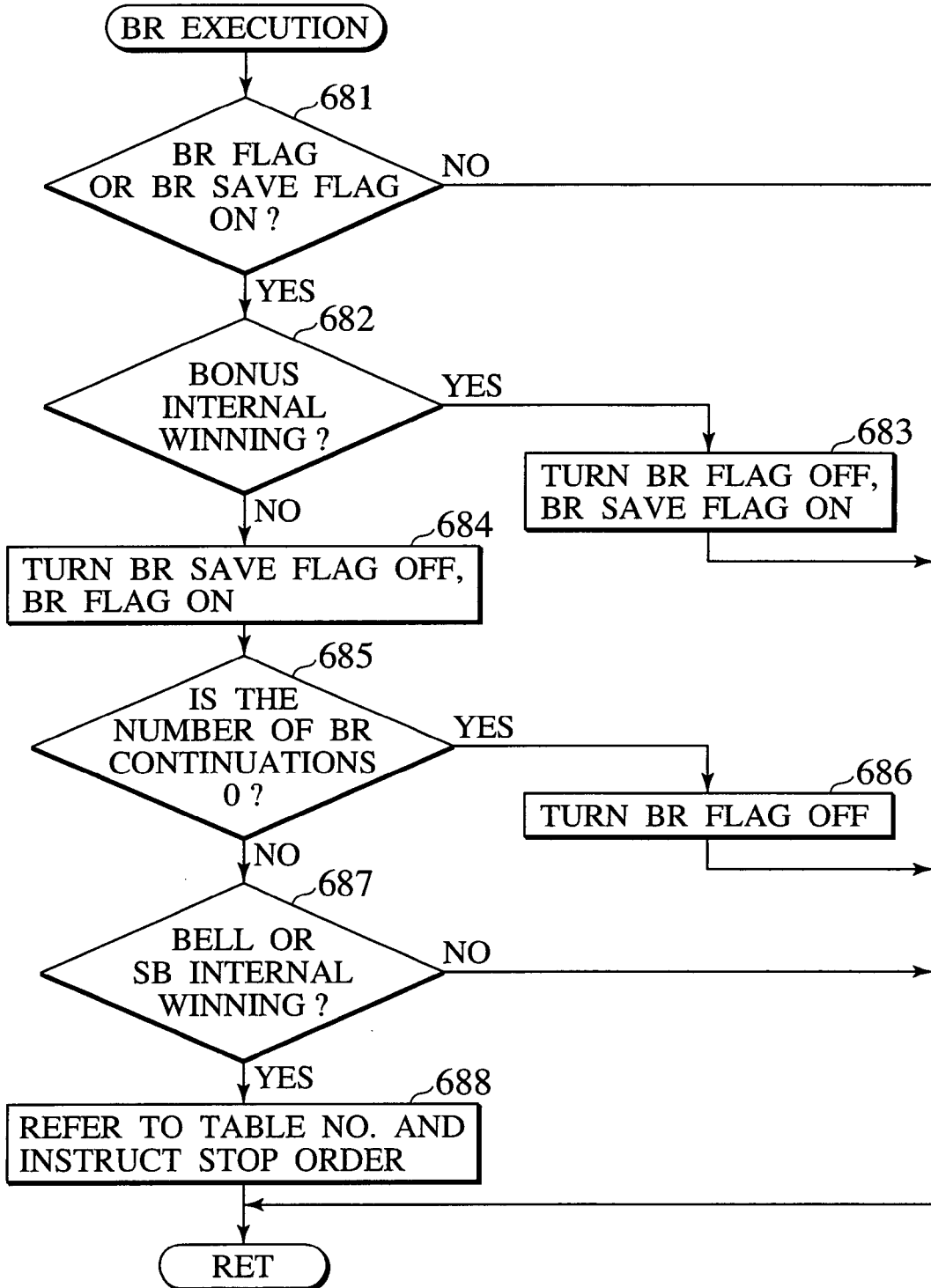

FIG.41

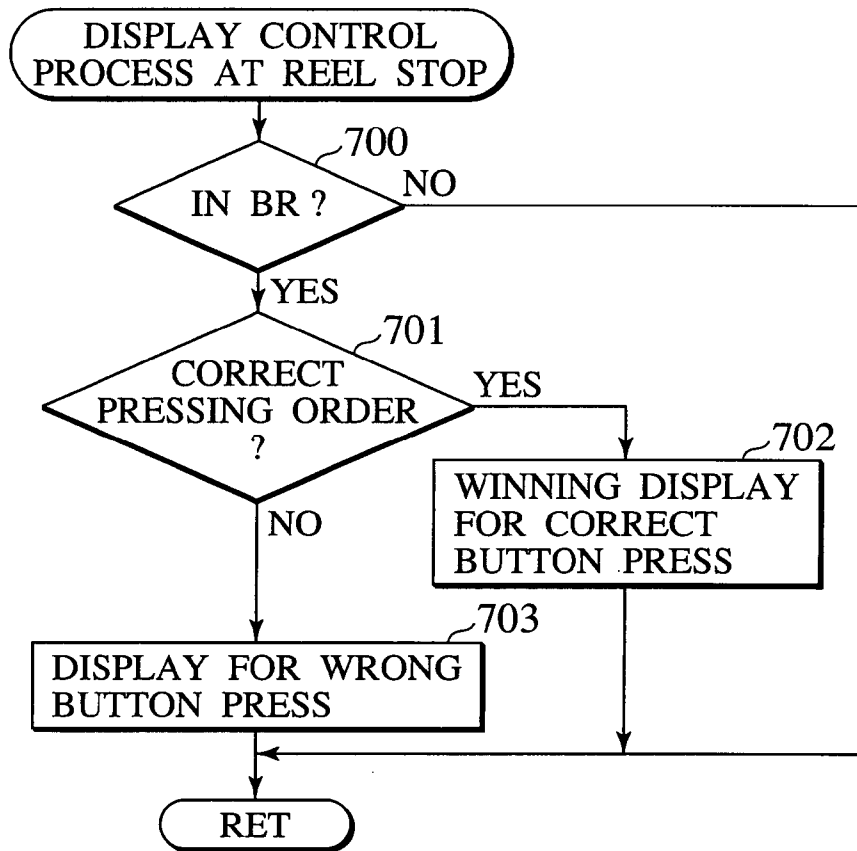

FIG.42

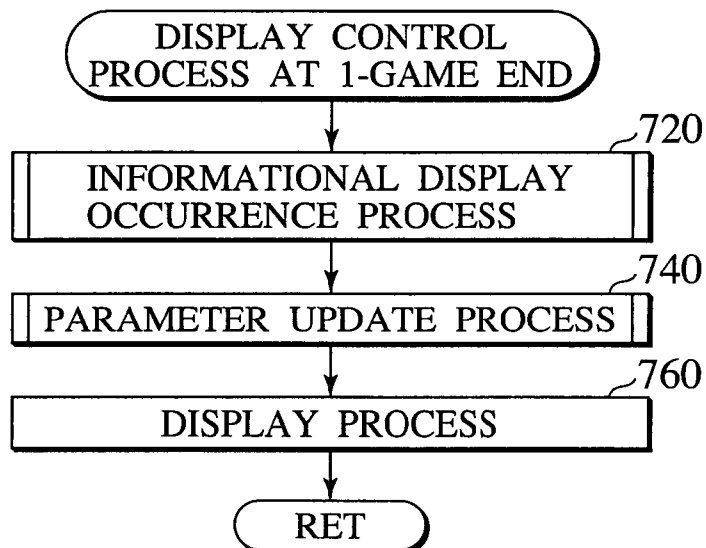

FIG.43

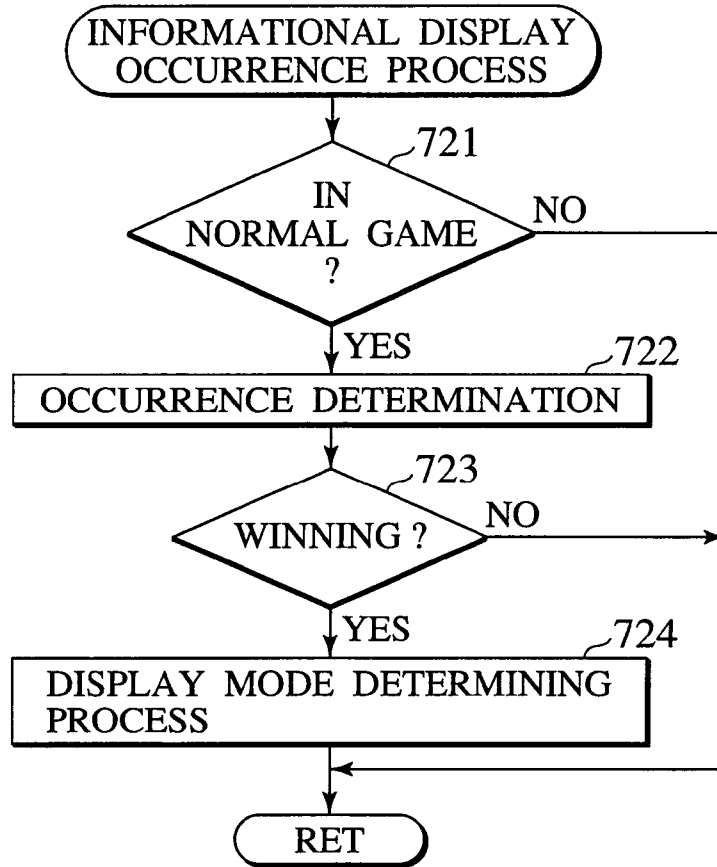

FIG.44

