



(12) EUROPEAN PATENT APPLICATION

(43) Date of publication:
13.05.1998 Bulletin 1998/20

(51) Int Cl. 6: B66C 13/06, B66C 13/08

(21) Application number: 97308691.1

(22) Date of filing: 30.10.1997

(84) Designated Contracting States:
AT BE CH DE DK ES FI FR GB GR IE IT LI LU MC
NL PT SE
Designated Extension States:
AL LT LV RO SI

(72) Inventors:
• Fujii, Noriyuki
Tokyo-to (JP)
• Kawase, Akira
Higashikurume-shi, Tokyo-to (JP)
• Asano, Hiroshi
Tokyo-to (JP)
• Yamashita, Yasushi
Urawa-shi, Saitama-ken (JP)

(30) Priority: 07.11.1996 JP 294912/96
14.11.1996 JP 302953/96

(74) Representative: Jennings, Nigel Robin et al
KILBURN & STRODE
20 Red Lion Street
London WC1R 4PJ (GB)

(71) Applicant: ISHIKAWAJIMA-HARIMA
JUKOGYO KABUSHIKI KAISHA
Chiyoda-ku Tokyo-to (JP)

(54) Container crane

(57) A container crane includes a trolley (9) adapted to be moved in a traverse direction along traverse rails (8), a head block (15) hoistably suspended from the trolley and a spreader (16), which is connected to the head block (15) and is adapted to grip and lift a container (4). Vibration or oscillation sensors (28) are arranged on the head block (15) or spreader (16) and are adapted to sense oscillation or vibration of the head block or spreader in the traverse direction of the trolley. The sensors (28) are arranged symmetrically with respect to the

transverse centre line (L) of the head block or spreader. Damping means (31) are also arranged on the head block or spreader, each of which includes a mass (29) movable in the traverse direction of the trolley and an actuator (30) arranged to move the movable mass in response to oscillation of the head block or spreader sensed by the sensors in a direction to counteract or suppress the oscillation. The damping means are also arranged symmetrically with respect to the transverse centre line (L) of the head block or spreader.

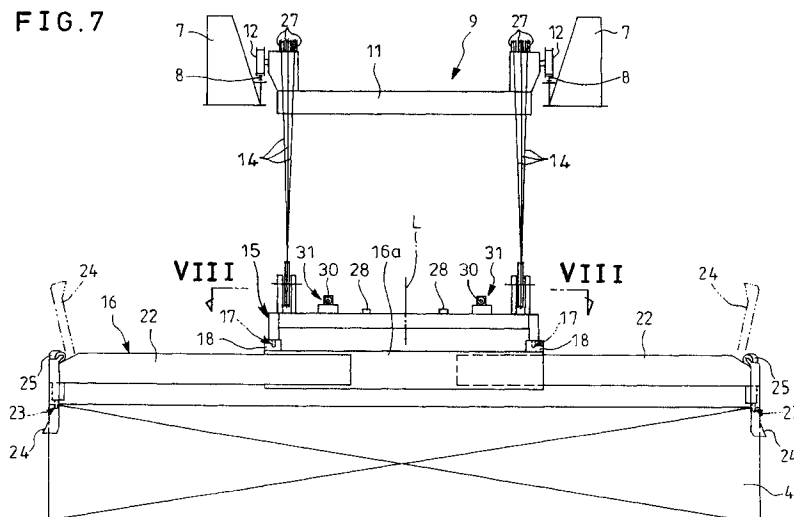

Description

The present invention relates to a container crane of the type including a trolley adapted to be moved in a traverse direction along traverse rails, a head block hoistably suspended from the trolley and a spreader which is connected to the head block and is adapted to grip a container.

A known container crane of this type is illustrated schematically in Figures 1 to 6 of the accompanying drawings, in which:

Figure 1 is a side view of the container crane;

Figure 2 is a side view of the head block and spreader of the container crane shown in Figure 1;

Figure 3 is a front view of the head block and spreader shown in Figure 2;

Figure 4 is an enlarged vertical sectional view of the twist lock shown in Figure 3;

Figure 5 is a view in the direction of the arrows V in Figure 4; and

Figure 6 is a view in the direction of the arrows VI in Figure 3.

The illustrated known container crane 3 is intended for loading and unloading containers 4 onto and from a container ship 1 moored at a quay 2. The crane 3 comprises upstanding legs 6 adapted to run along rails 5 on the quay 2, girders 7 on top of the legs 6 and extending substantially horizontally towards the sea, traverse rails 8 extending along the girders 7 and a trolley 9 adapted to be moved in a traverse direction along the rails 8.

As shown in Figures 2 and 3, the trolley 9 comprises a trolley body 11 with traverse wheels 12 for rolling on the rails 8. Tied to the trolley body 11 are opposite ends of a traverse rope 13 which is wound around a traverse drum (not shown) in a machine room 10 (see Figure 1) and which extends under tension longitudinally of the girders 7. Rotation of the traverse drum in the normal or reverse direction causes the trolley 9 to be moved in the traverse direction.

The trolley 9 carries a head block 15 which is suspended from the trolley 9 by winding ropes 14 which in turn are wound around a hoist drum (not shown) in the machine room 10 and which extend under tension longitudinally of the girders 7. Rotation of the hoist drum in the normal or reverse direction causes the head block 15 to be hoisted up or down.

Detachably interlocked with the head block 15 by means of twist locks 17 is a spreader 16 which grips a container 4.

As shown in Figures 4 and 5, each of the twist locks 17 comprises a lock pin 20 which is inserted into a cor-

responding suspender 18 of the spreader 16 through a slot 19 in the suspender 18 and is turned by actuation of a hydraulic cylinder 21 to interlock the head block 15 with the spreader 16.

As shown in Figures 3 and 6, the spreader 16 comprises a spreader body 16a with extension frames 22, each of which is mounted on the body 16a to be slidable by a drive (not shown) perpendicularly of the traverse direction of the trolley 9. Each frame 22 is provided at its outer corners with twist locks 23 for gripping the container 4 and with guide arms 24 for moving the twist locks 23 into position for engagement with the container 4. The spreader 16 can grip containers 4 of different lengths since the difference in length of the containers 4 can be compensated for by sliding displacement of the frames 22.

Like the twist locks 17, the twist locks 23 can interlock the spreader 16 with a container 4 by inserting a lock pin of a twist lock 23 into the container 4 through a slot therein and turning it by actuation of a hydraulic cylinder. The guide arms 24 can be swung from an upper, turned-over open position into position for engagement with a corner of the container 4 by actuation of a hydraulic motor 25. Therefore, the spreader 16 can be correctly positioned with respect to the container 4 and the twist locks 23 can be positively engaged with the container 4 even if there may be some positional inaccuracy in lowering the spreader 16 interlocked with the head block 15 onto the container 4.

In general, when a container 4 is to be loaded onto the container ship 1 by the container crane 3, the container 4 is gripped by the spreader 16 interlocked with the head block 15 suspended from the trolley 9. The spreader 16 is then hoisted up and the trolley 9 is moved in the traverse direction to a predetermined position above the container ship 1. The spreader 16 is then lowered or hoisted down to place the container 4 on the container ship 1.

The container 4 generally has a predetermined destination on the container ship 1. Therefore, in accordance with the coordinates of the destination of the container 4, the trolley 9 may be automatically moved in the traverse direction and only hoisting-up and -down of the spreader 16 need be carried out manually by an operator in an operation room 26.

However, in automatically operated traverse movement operation of the trolley 9 in which the trolley 9 is simply accelerated to a preset speed and is then moved at a uniform speed and is decelerated to stop at the predetermined position (the destination of the container 4), the spreader 16 gripping the container tends to swing or oscillate due to inertia when accelerated or decelerated or as a result of any wind that may be blowing, resulting in difficulties in the loading and unloading operation.

Conventionally, in order to prevent the container 4 from swinging or oscillating during traversing movement of the trolley 9, the sheaves 27 on the trolley 9, which

support the hoist ropes 14 for the head block 15 and spreader 16, are separated from each other by drive means (not shown) so that the hoist ropes 14 for the head block 15 and spreader 16 are in the shape of the letter V in order to suppress swinging or oscillation of the head block 15 and spreader 16. Such a mechanical swing- or oscillation-suppressing mechanism is effective only to suppress sway (pendulum-like swinging or oscillation; see Figure 2) and is substantially ineffective to suppress rocking (rotational swinging or oscillation around an axis below the suspended position; see Figure 2) or skew (swinging or oscillation in a horizontal plane; see Figure 6).

It is therefore the object of the present invention to provide a container crane which can suppress not only sway but also rocking and skew of the head block and spreader and can thereby render efficient loading and unloading operations possible.

According to the present invention, a container crane of the type referred to above is characterised by two or more oscillation sensors arranged on the head block or spreader and adapted to sense oscillation of the head block or spreader in the traverse direction of the trolley, the sensors being arranged symmetrically with respect to the transverse centre line of the head block or spreader, respectively, and two or more damping means arranged on the head block or spreader, each including a mass movable in the traverse direction of the trolley and an actuator arranged to move the movable mass in response to oscillation of the head block or spreader sensed by the sensors in a direction to counteract the oscillation, the damping means being arranged symmetrically with respect to the transverse centre line of the head block or spreader, respectively.

Thus if swinging oscillation or vibration of the head block or spreader, which are interlocked together, should occur, such movement in the traverse direction of the trolley is sensed by the vibration sensors which produce a signal indicative of such movement of the head block or spreader at the position of the sensor in question. This signal is supplied to the actuator of the associated damping means, or possibly two or more associated damping means, which moves the associated mass in a direction and at a rate which counteracts and thus substantially suppresses the vibration or oscillation of the head block and spreader.

If only a single damping means were provided, it would be able to cope with and suppress sway and rocking of the head block but could not suppress skew. However, the provision in accordance with the invention, of two or more vibration sensors and damping means which are arranged symmetrically with respect to the transverse centre line of the elongate head block or elongate spreader means that any type of vibration or oscillation, such as sway, rocking or skew, of the head block and spreader can be coped with and suppressed.

Further features and details of the invention will be apparent from the following description of two specific

embodiments which is given by way of example with reference to Figures 7 to 10 of the accompanying drawings, in which:

5 Figure 7 is a front view of one embodiment of the present invention;

Figure 8 is a view in the direction of the arrows VIII in Figure 7;

10 Figure 9 is a front view of a further embodiment of the present invention; and

15 Figure 10 is a view in the direction of the arrows X in Figure 9.

Figures 7 and 8 illustrate an embodiment of the present invention in which the same components as in Figures 11 to 6 are referred to by the same reference numerals and whose basic arrangement is the same as that in the known system shown in Figures 1 to 6. As shown, vibration or oscillation sensors 28, such as acceleration sensors or speed sensors, for sensing any oscillation of the head block 15 in the traverse direction of the trolley 9 are arranged symmetrically with respect to the transverse centre line L of the head block 15. Active damping means 31 each having a mass 29 movable in the traverse direction of the trolley 9 and an actuator 30 for driving the movable mass 29 in the direction to counteract the oscillation of the head block 15 sensed by the vibration sensor 28 are also arranged symmetrically with respect to the transverse centre line L of the head block 15.

Each of the damping means 31 includes a nut member 33 screwed onto a screw shaft 32 extending in the traverse direction of the trolley 9 and the movable mass 29 is integrally mounted on the nut member 3. Rotation of the screw shaft 32 by the actuator 30 forcibly causes the movable mass 29 to be moved in the same cycle and with the same wavelength as the oscillation of the head block 15 but with a phase difference of 90° therefrom.

In use, when oscillation of the head block 15 occurs, this oscillation in the traverse direction of the trolley 9 is sensed by each of the oscillation or vibration sensors 28, which are arranged symmetrically with respect to the transverse centre line L of the head block 15. In response to the sensed oscillation of the head block 15, the movable mass 29 of each of the damping means 31 is driven independently by the associated actuator 30 so as to counteract or damp the oscillation.

If only one damping means 31 were provided, it could cope with sway and rocking of the head block 15 but could not cope with skew. However, in the embodiment shown in Figures 7 and 8, both the vibration sensors 28 and the damping means 31 are arranged symmetrically with respect to the transverse line L of the head block 15 and can cope with and suppress any type

of oscillation such as sway, rocking or skew of the head block 15 and thus of the spreader 16 and any container carried by it. The loading and unloading operations can thus be performed efficiently.

Figures 9 and 10 illustrate a further embodiment of the present invention in which the same components as in Figures 7 and 8 are referred to by the same reference numerals. Oscillation sensors 28, such as acceleration sensors and speed sensors, for sensing oscillation of the spreader 16 in the traverse direction of the trolley 9 are arranged on the spreader 16, symmetrically with respect to the transverse centre line L of the spreader 16. Also, two active damping means 31, each having a mass 29 movable in the traverse direction of the trolley 9, and an actuator 30 for driving the movable mass 29 in a direction to counteract the oscillation of the spreader 16 detected by the vibration sensors 28 are arranged on the spreader 16 symmetrically with respect to its transverse centre line L.

The detailed construction and operation of the damping means are the same as those described above in conjunction with Figures 7 and 8. The same advantages are also obtained in that sway, rocking or skew of the spreader 16 may again be suppressed, thereby permitting loading and unloading operations to be performed efficiently.

Claims

1. A container crane including a trolley (9) adapted to be moved in a traverse direction along traverse rails (8), a head block (15) hoistably suspended from the trolley (9) and a spreader (16), which is connected to the head block (15) and is adapted to grip a container (4), characterised by two or more oscillation sensors (28) arranged on the head block (15) or spreader (16) and adapted to sense oscillation of the head block or spreader in the traverse direction of the trolley (9), the sensors (28) being arranged symmetrically with respect to the transverse centre line (L) of the head block or spreader, respectively, and two or more damping means (31) each arranged on the head block (15) or spreader (16), each including a mass (29) movable in the traverse direction of the trolley (9) and an actuator (30) arranged to move the movable mass (29) in response to oscillation of the head block or spreader sensed by the sensors (28) in a direction to counteract the oscillation, the damping means (31) being arranged symmetrically with respect to the transverse centre line (L) of the head block or spreader, respectively.

55

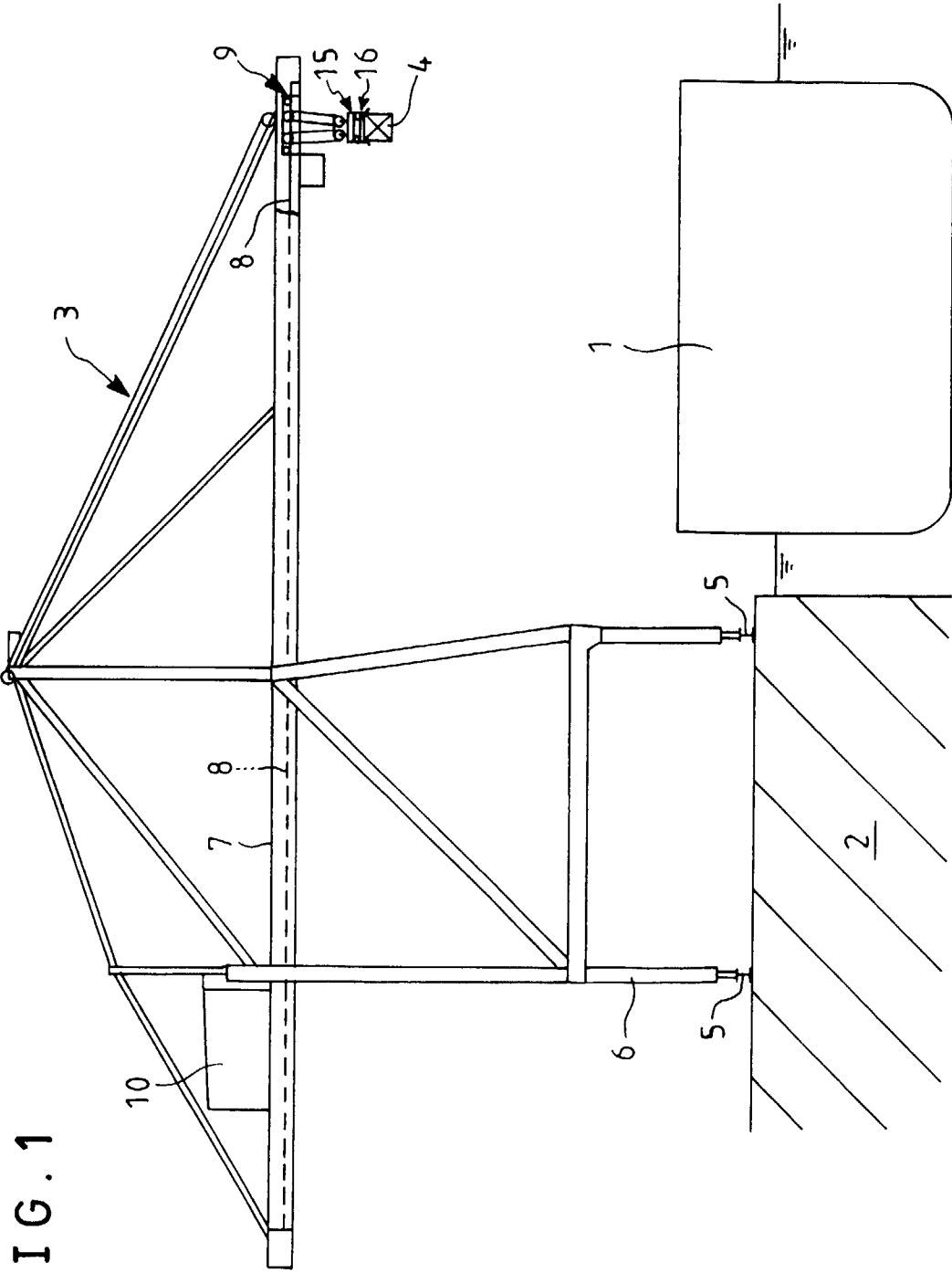
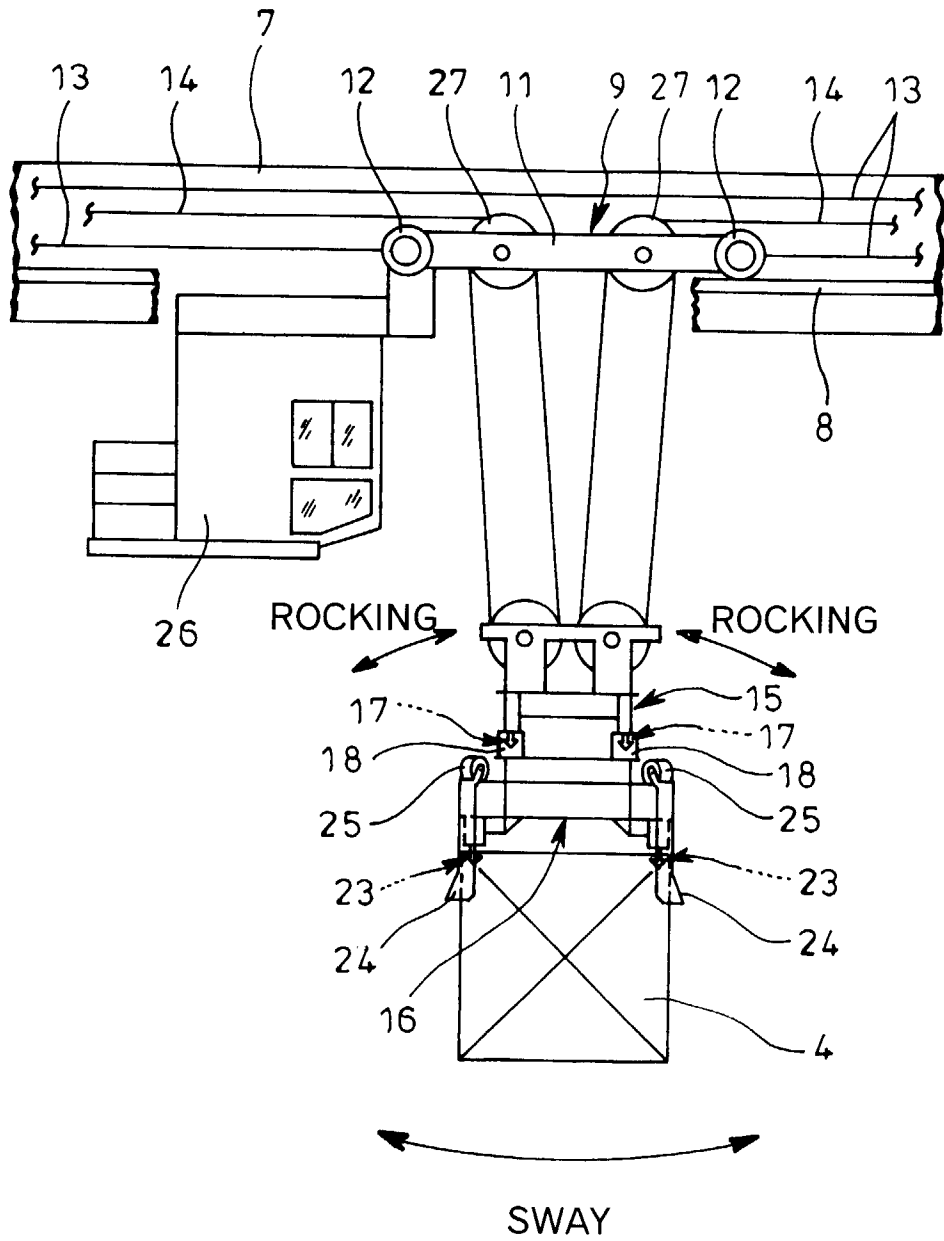

FIG. 1

FIG. 2



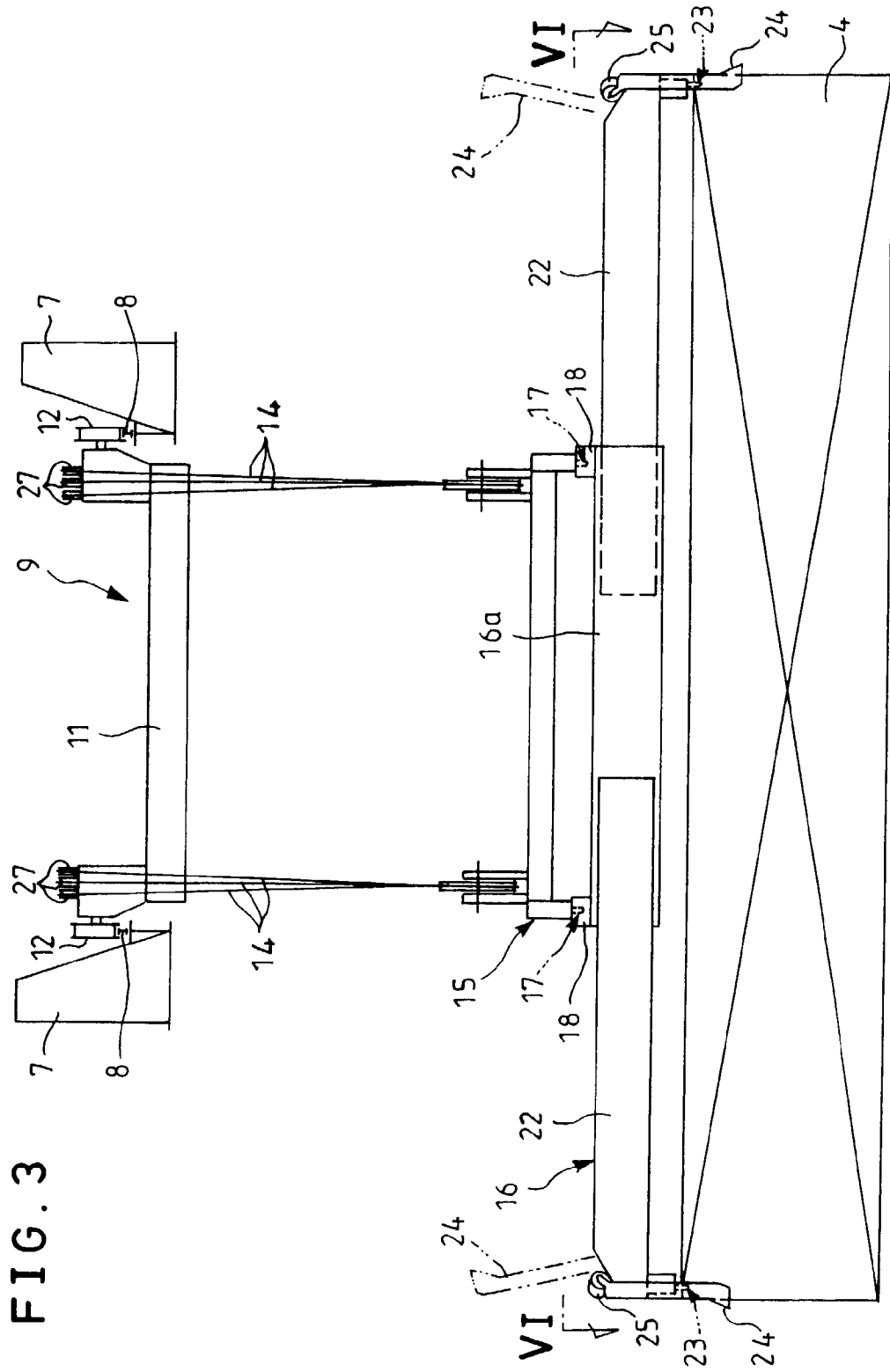

FIG. 3

FIG. 4

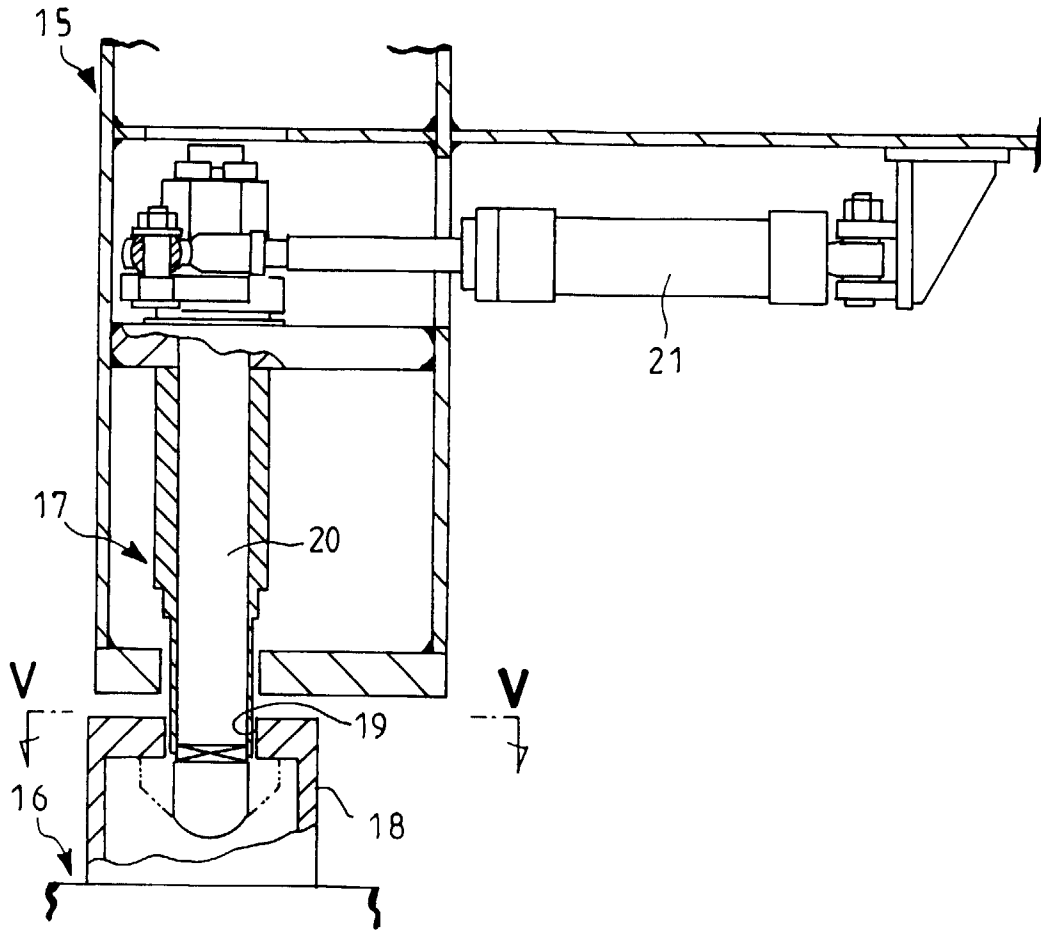

FIG. 5

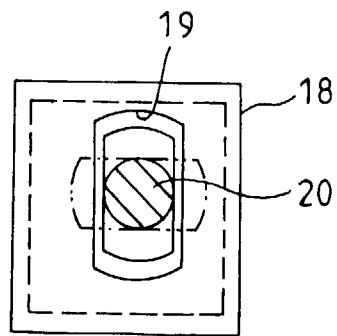
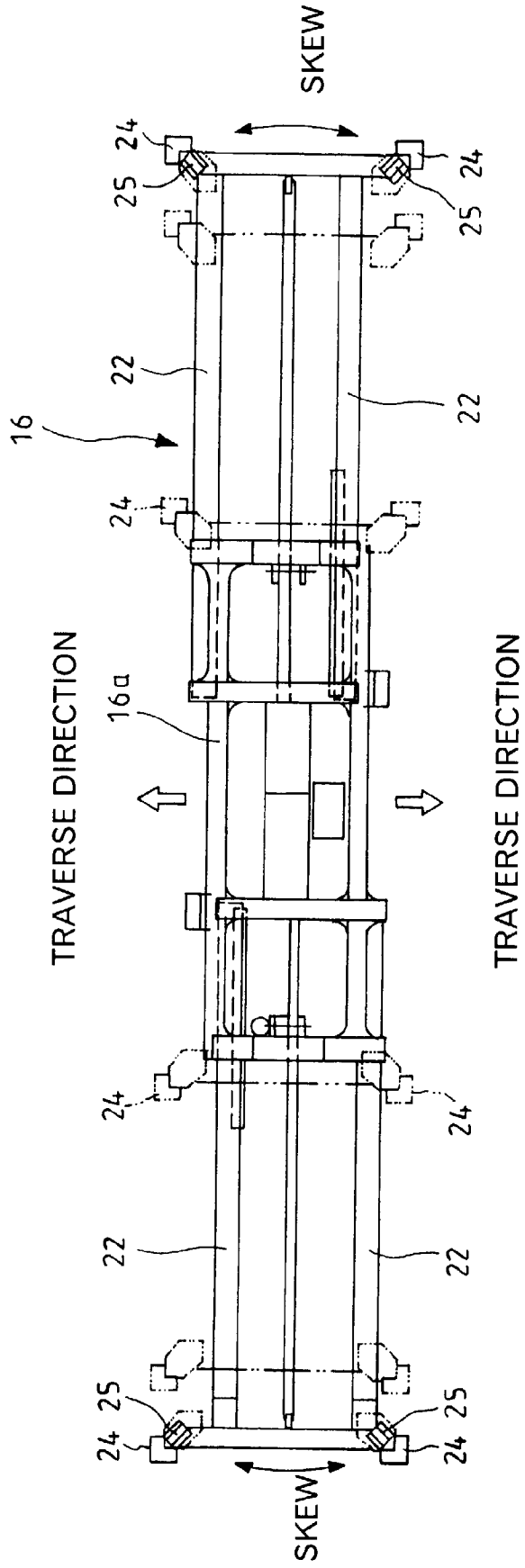

FIG. 6



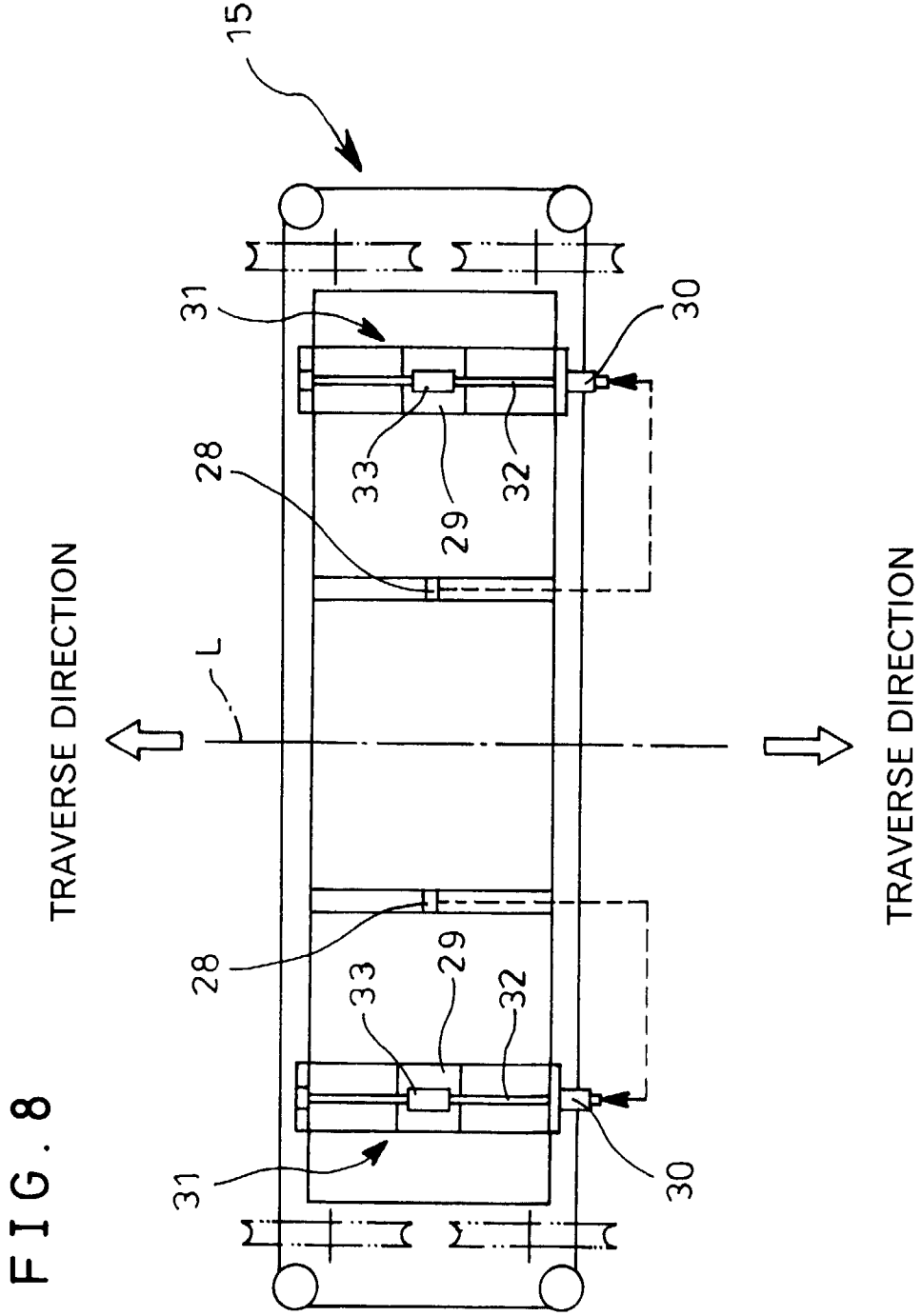

FIG. 9

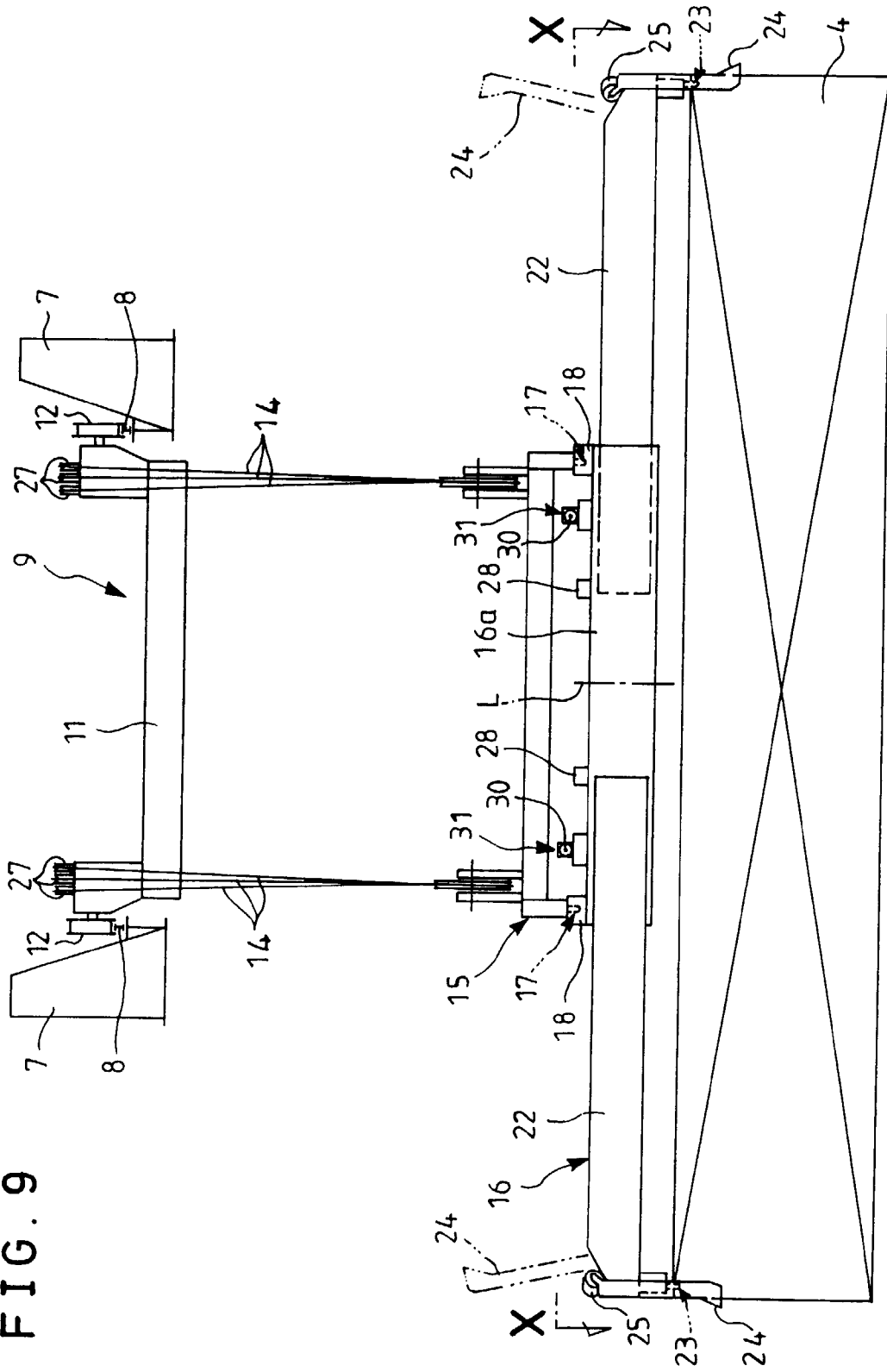
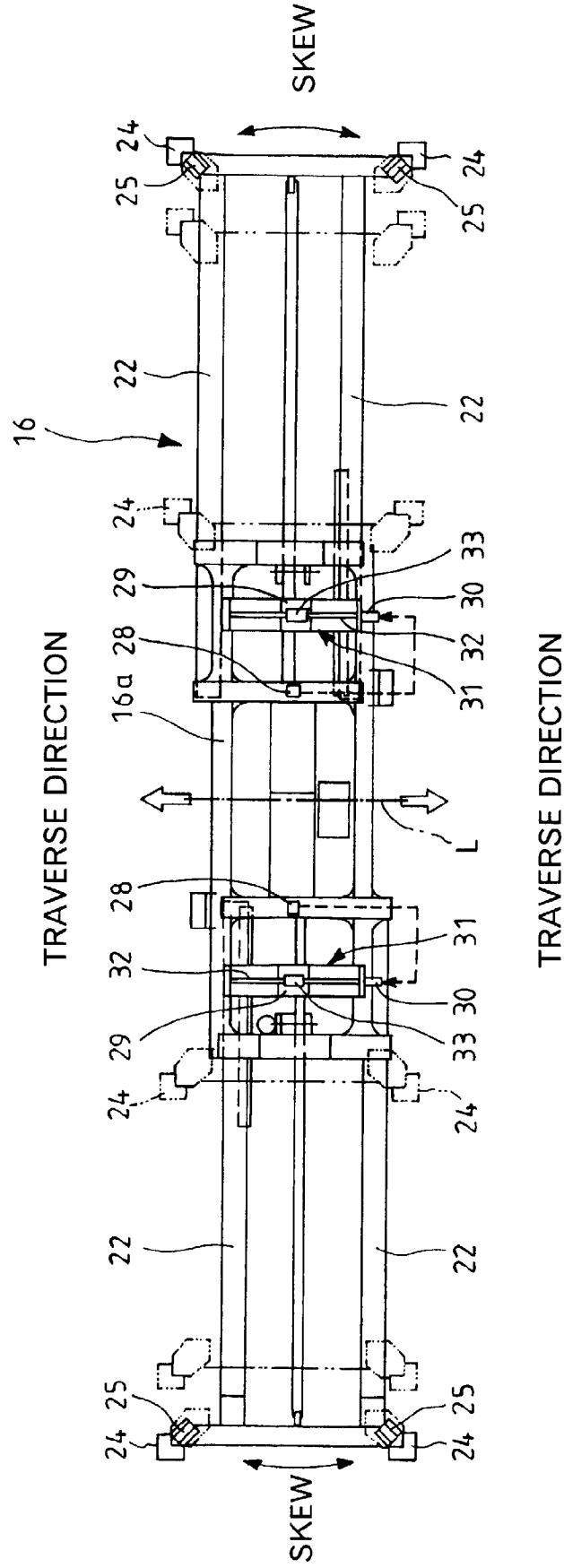

FIG. 10





European Patent
Office

EUROPEAN SEARCH REPORT

Application Number
EP 97 30 8691

DOCUMENTS CONSIDERED TO BE RELEVANT			
Category	Citation of document with indication, where appropriate, of relevant passages	Relevant to claim	CLASSIFICATION OF THE APPLICATION (Int.Cl.6)
A	GB 2 300 177 A (MITSUBISHINJUKOGYO) * the whole document *	1	B66C13/06 B66C13/08
A	US 5 186 342 A (SHIMIZU)		
A	US 1 694 084 A (STRAIGHT)		
A	US 3 210 114 A (LAWTON)		
A	DE 23 56 504 A (FRIED. KRUPP)		
			TECHNICAL FIELDS SEARCHED (Int.Cl.6)
			B66C
The present search report has been drawn up for all claims			
Place of search		Date of completion of the search	Examiner
THE HAGUE		9 February 1998	Van den Berghe, E
CATEGORY OF CITED DOCUMENTS		T : theory or principle underlying the invention E : earlier patent document, but published on, or after the filing date D : document cited in the application - : document cited for other reasons & : member of the same patent family, corresponding document	
X : particularly relevant if taken alone Y : particularly relevant if combined with another document of the same category A : technological background C : non-written disclosure P : intermediate document			

EPO FORM 1503 03 82 (P01/C01)