



US 20080156314A1

(19) **United States**

(12) **Patent Application Publication**
Heuer et al.

(10) **Pub. No.: US 2008/0156314 A1**

(43) **Pub. Date: Jul. 3, 2008**

(54) **VACUUM TUBES FOR SOLAR COLLECTORS WITH IMPROVED HEAT TRANSFER**

(30) **Foreign Application Priority Data**

Jun. 23, 2005 (EP) 05 013 591.2

(75) Inventors: **Dirk Heuer**, Augsburg (DE);
Walter Zimmerly, Augsburg (DE);
Werner Guckert, Baar (DE)

Publication Classification

(51) **Int. Cl.**
F24J 2/50 (2006.01)
F24J 2/48 (2006.01)
(52) **U.S. Cl.** **126/650; 126/652**

Correspondence Address:
LERNER GREENBERG STEMER LLP
P O BOX 2480
HOLLYWOOD, FL 33022-2480

(57) **ABSTRACT**

Heat transfer between an absorber and heat carrier tubes is simplified by using heat conducting elements which are made of compressed graphite expandate in vacuum tubes for solar collectors. The heat conducting element which is made of compressed graphite expandate can, for example, be embodied in a form-locking fit as an intermediate layer between an absorber internal wall and the carrier construction which can receive the heat carrier tubes or as a heat transfer component which is fitted into the absorber tube and which receives the heat carrier tubes in a form-locking fit.

(73) Assignee: **SGL Carbon Aktiengesellschaft**,
Wiesbaden (DE)

(21) Appl. No.: **11/964,291**

(22) Filed: **Dec. 26, 2007**

Related U.S. Application Data

(63) Continuation of application No. PCT/EP2006/004602, filed on May 16, 2006.

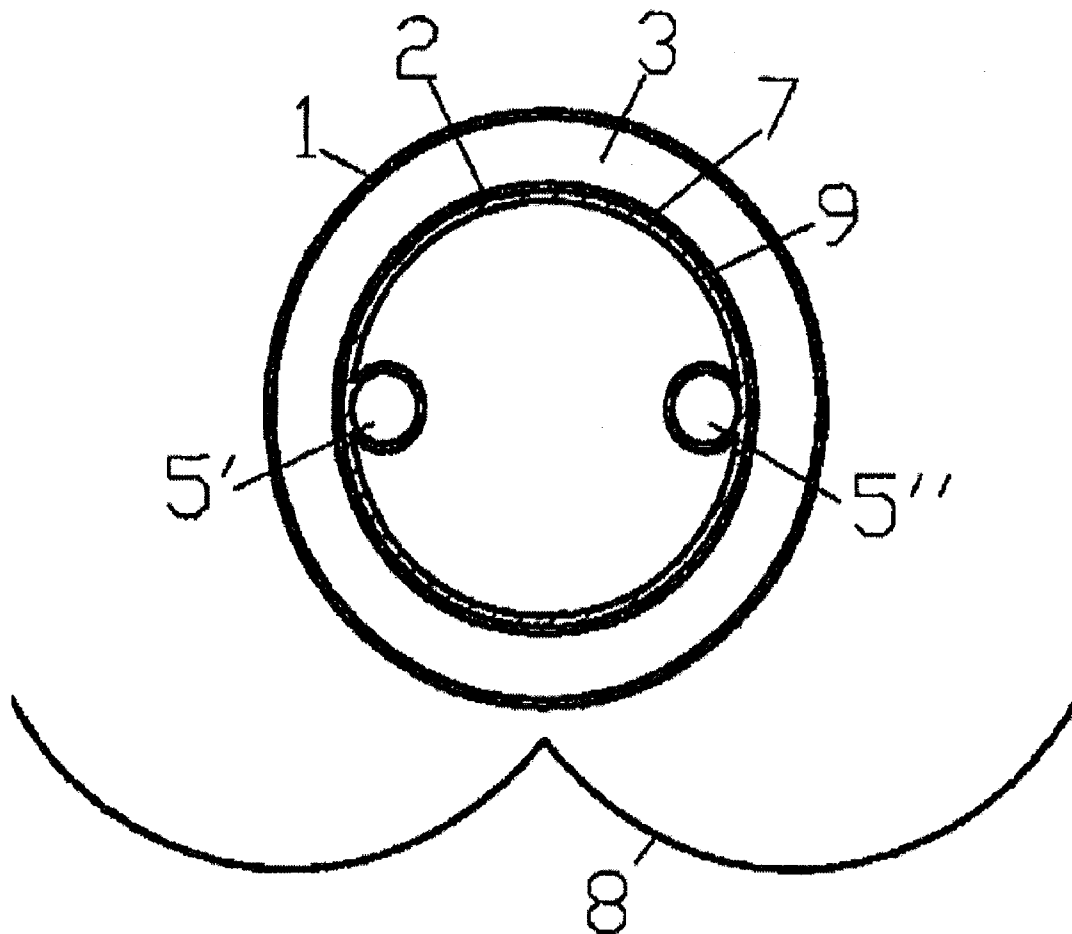

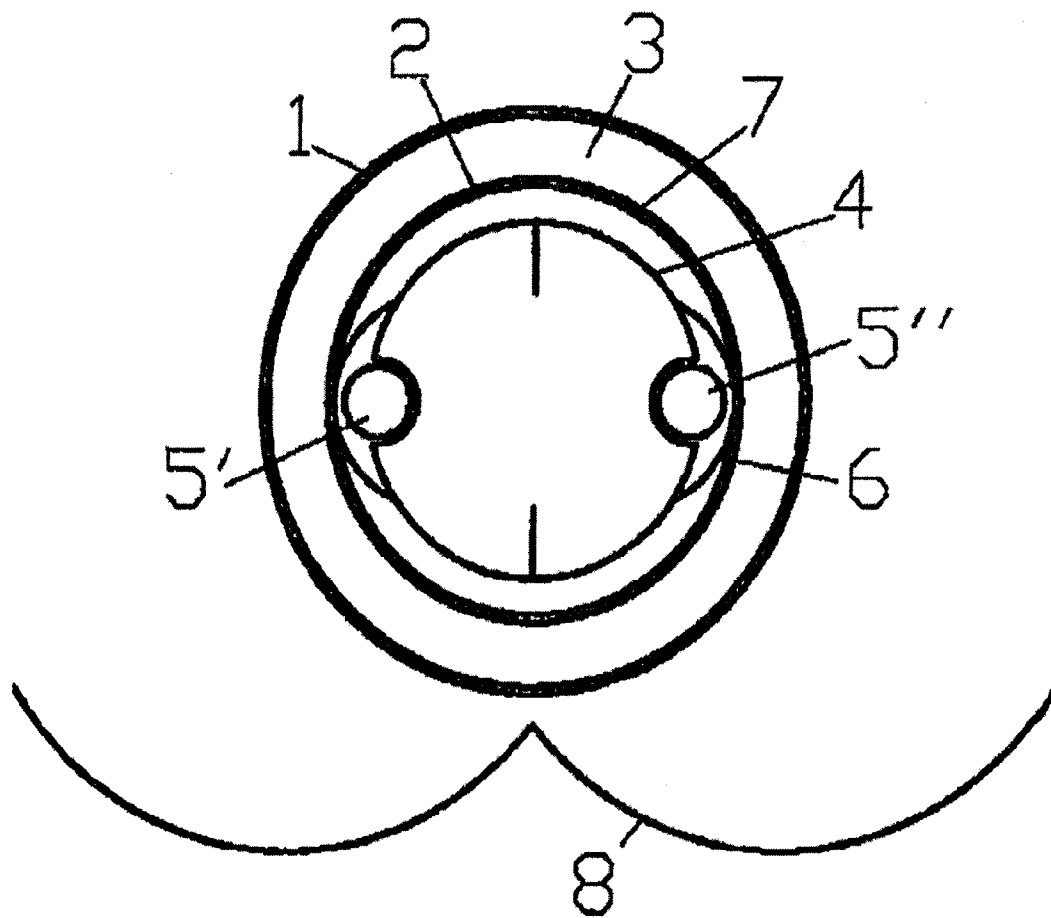

FIG.1
PRIOR ART

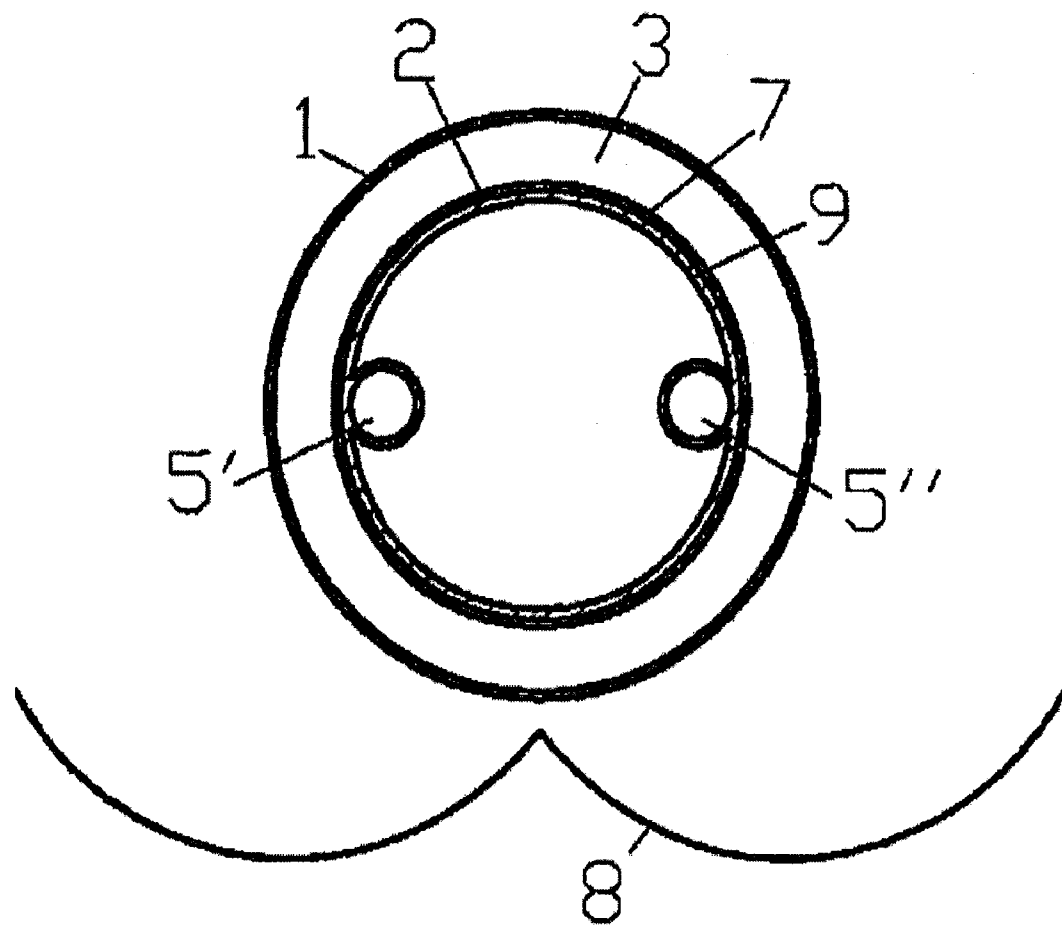

FIG.2

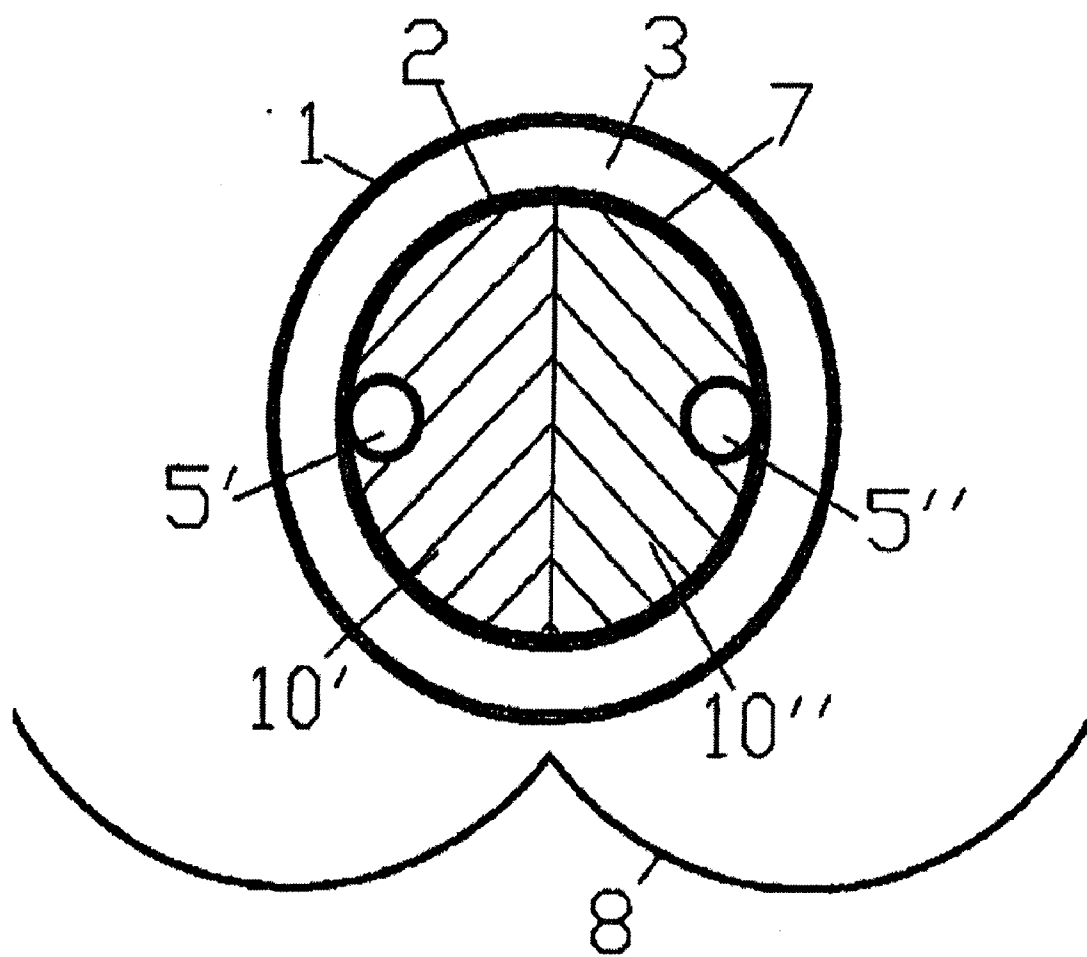

FIG.3

FIG.4A

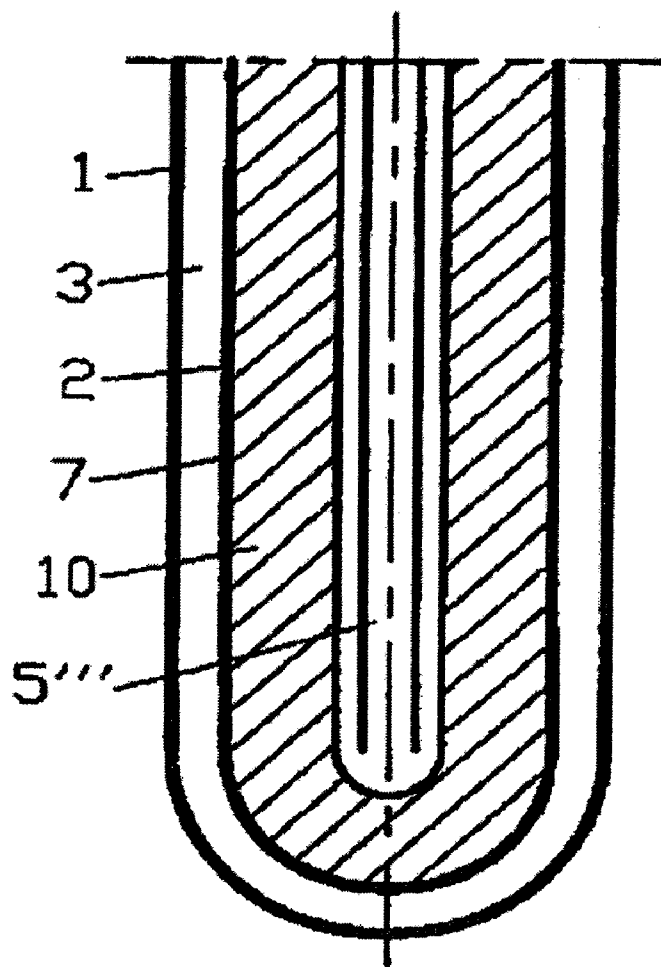
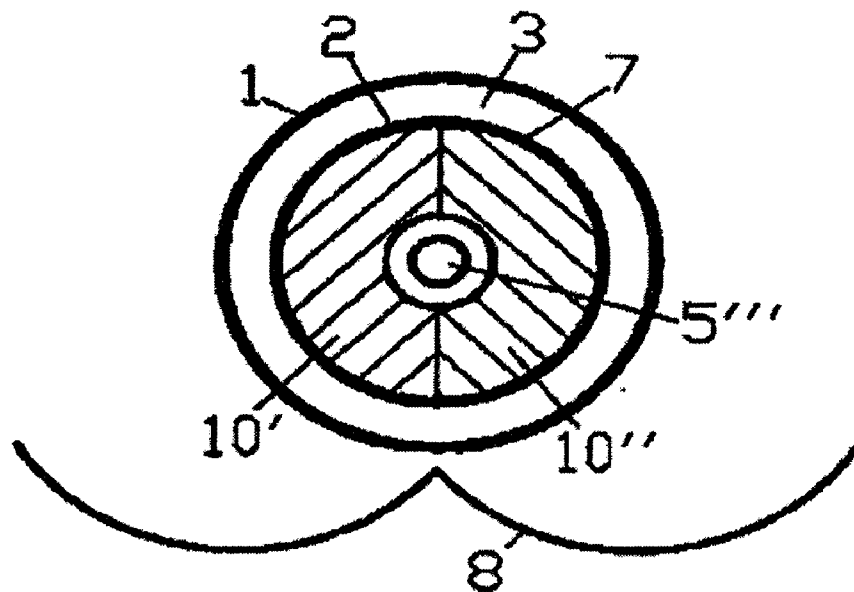

FIG.4B

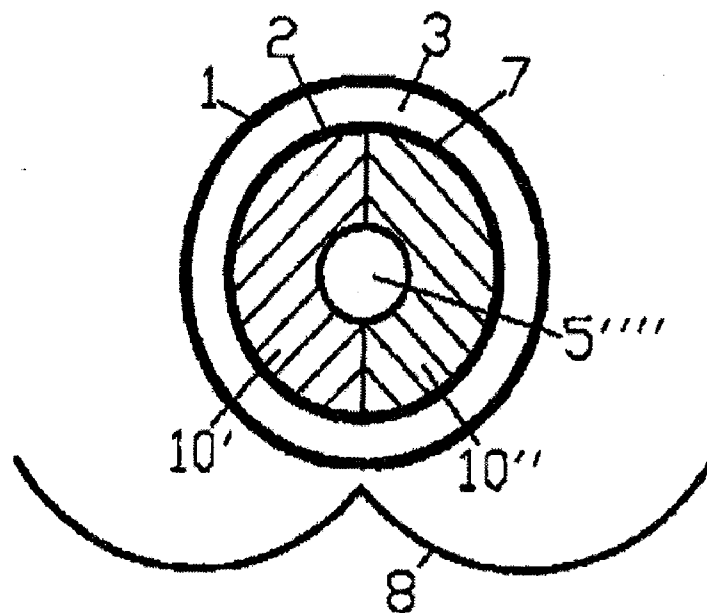

FIG.5A

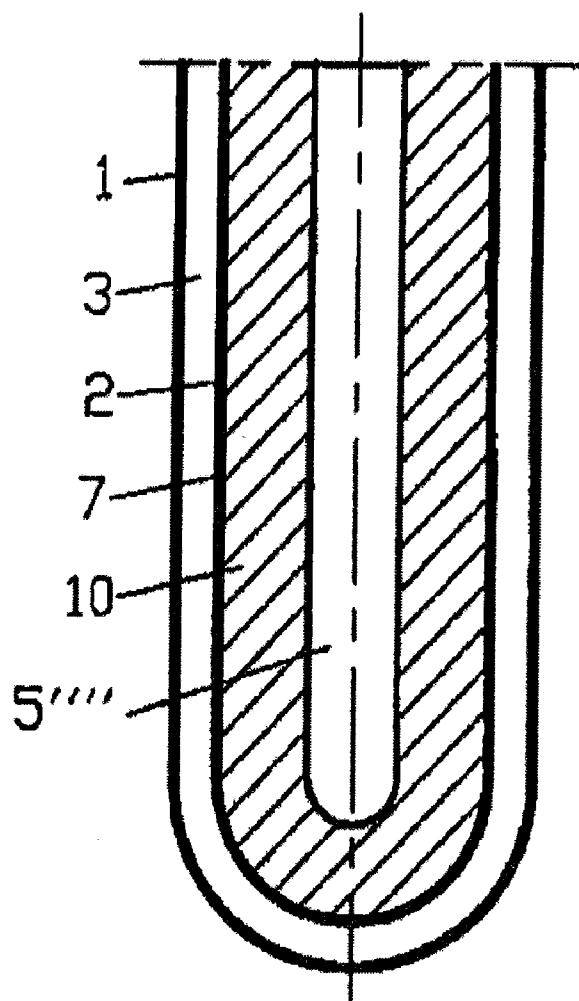

FIG.5B

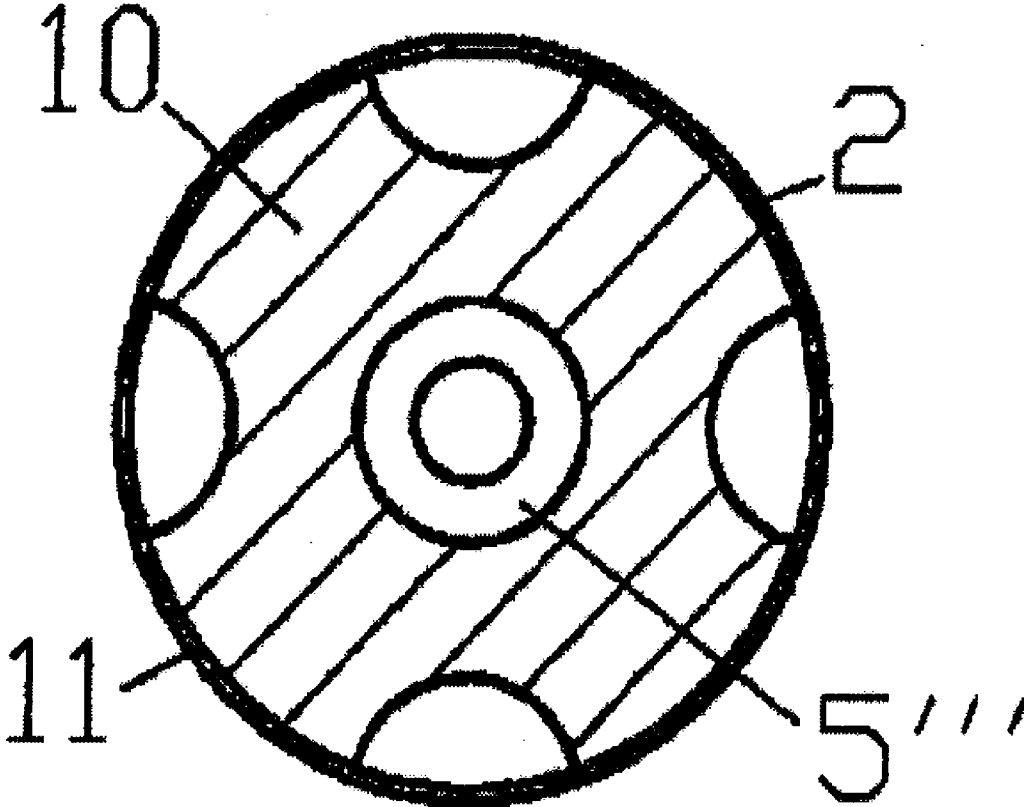

FIG. 6

VACUUM TUBES FOR SOLAR COLLECTORS WITH IMPROVED HEAT TRANSFER

CROSS-REFERENCE TO THE RELATED APPLICATION

[0001] This is a continuing application, under 35 U.S.C. §120, of copending international application No. PCT/EP2006/004602, filed May 16, 2006, which designated the United States; this application also claims the priority, under 35 U.S.C. §119, of European patent application No. EP 05 013 591.2, filed Jun. 23, 2005; the prior applications are herewith incorporated by reference in their entirety.

BACKGROUND OF THE INVENTION

[0002] The present invention relates to vacuum tubes for solar collectors.

[0003] One known configuration of vacuum tube solar collectors (see FIG. 1) contains so-called Sydney tubes. These are dual-walled glass vessels configured like a thermos bottle, are formed of two glass tubes 1 and 2, inserted concentrically one into the other, that are each closed at one end forming a hemisphere, and are fused together at the other end, which is not visible in the cross-section depiction of FIG. 1. A hermetically sealed gap 3 between the glass tubes is evacuated to avoid heat losses.

[0004] In the non-evacuated interior space of interior glass tube 2 there is a heat transfer tube secured in a carrier structure 4, for example a U-shaped tube, which has a heat-transfer fluid flowing through it. The cross-sectional depiction in FIG. 1 shows two posts 5', 5'' of the U tube for inflow of the heat-transfer fluid to be heated, and outflow of heated fluid to the heat exchanger or storage device. For the most part the carrier structure 4 has heat transfer plates 6 made of aluminum or copper, into which heat transfer pipes, customarily formed of copper or brass, are embedded or folded in.

[0005] Along with the U-shaped tube version, other types of configuration and function of heat transfer tubes are also known. For example, the heat transfer fluid can flow through the collector tubes lengthwise, and then the heat transfer tube at the upper and at the lower end of the collector tube is open. The lead-in is located in a receptacle at the lower pipe end, and at the upper pipe end is a receptacle for the return.

[0006] The heat transfer pipe can also have coaxial flow going through it. In this case, the heat transfer pipe formed of two tubes placed coaxially one inside the other, with the open end of the inner coaxial tube (the heat transfer tube) having the outer coaxial tube projecting beyond it. German patent DE 198 21 137, for example, describes a heat transfer fluid guided in this way.

[0007] In addition, instead of a pipe that has a heat transfer fluid flowing through it, it is known to provide a so-called heat pipe, in which there is a fluid vaporized by the absorbed heat. The fluid vapor rises in the heat pipe, and exhausts the absorbed heat via a heat exchanger. The condensed fluid then again flows back to the lower end of the heat pipe. So that the described process of evaporation and condensation can be run, the pipes must be structured with a minimum inclination from the horizontal.

[0008] The inner glass tube (absorber tube) 2 is provided, on its surface that faces the vacuum gap, with a selective absorber layer 7, made for example, from aluminum nitride.

A high-reflection mirror 8 placed behind the collector tubes causes solar radiation to also reach the rear side of the cylindrical absorber tube.

[0009] Heat is absorbed from the incident sunlight in the absorber layer 7. Via the heat transfer plates 6, the heat is transferred to the heat transfer pipes. The heated heat transfer fluid flows to a heat exchanger in which the heat is removed for further exploitation.

[0010] In these solar collector vacuum tubes according to the state of the art, there is a relatively high heat transfer resistance between the absorber tube 2 and the heat transfer pipes 5', 5'', because in the known carrier structure 4 with heat transfer plates 6, only a relatively limited contact surface is available for heat transmission. Between the metallic components or metal and glass, due to the rigidity of these materials and the irregularities and unevenness on the surfaces which is always present, the shape cannot be made to be without gaps, so that insulating air bridges are always present. In addition, as the collector stands idle, increasing degradation of the form fitting is to be expected due to increasing material fatigue based on it frequently undergoing thermally-induced expansion and contraction cycles.

[0011] A further problem is differing thermal expansion of copper and aluminum, if use is made of heat transfer plates made of aluminum and heat transfer pipes made of copper.

SUMMARY OF THE INVENTION

[0012] It is accordingly an object of the invention to provide vacuum tubes for solar collectors with improved heat transfer that overcomes the above-mentioned disadvantages of the prior art devices of this general type.

[0013] With the foregoing and other objects in view there is provided, in accordance with the invention, a solar collector vacuum tube. The solar collector vacuum tube contains two glass tubes including an inner glass tube and an outer glass tube placed one inside another concentrically. Each of the glass tubes is closed in a hemispheric shape at a first end, and fused to each other at a second end. The two glass tubes define a gap there-between and the gap is evacuated. Pipes functioning as heat transfer tubes are disposed in an interior space of the inner glass tube and through which a heat transmission medium flows. A heat conduction element is disposed in the interior space of the inner glass tube and is made of a compressed graphite expandate. The heat conduction element has a first side forming a form-locking connection with the interior wall of the inner glass tube and a second side forming a form-locking connection with adjoining surfaces of the heat transfer tubes.

[0014] A proposal is made according to the invention to facilitate heat transfer between the absorber tube and the heat transfer pipes, by using heat transfer elements made of compressed graphite expandate. Graphite expandate is distinguished both by high thermal conductivity and by being able to be shaped easily, and by outstanding adaptation to adjoining surfaces. Therefore, using compressed graphite expandate, an almost gapless, full-surface form fit can be attained between the heat-conducting components.

[0015] According to the invention, a heat transfer element made of compressed graphite expandate is placed in the inner glass tube, with full-surface form fit on the one hand to the adjoining surfaces of the heat transfer element with the interior wall of the inner glass tube, and on the other hand to the heat transfer tubes and, if necessary, a carrier structure that receives the heat transfer tube. In this regard the invention is

not bound to a certain type of tube placement of the heat transfer medium, but is also suitable for U-shaped as well as ones that flow through from beneath upwards and also coaxial heat transfer tubes or heat pipes or a combination thereof. Therefore, in what follows, the overall term heat transfer tube is used, if reference is not made to a special pipe embodiment.

[0016] Due to the full-surface form fit between the inner wall of the inner glass tube and the heat transfer element of expanded graphite, in the invention-specific arrangement, in contrast to the state of the art, there are no points of frictional contact between the glass and metal. Thereby, damage to the glass tube is avoided.

[0017] The thermal expansion of the expanded graphite is minimal, and therefore during times when the solar collector is idle, no significant material fatigue of the heat transfer element is to be expected.

[0018] For example, the heat transfer element made of compressed graphite expandate can be embodied as a form-fitted intermediate layer between the inner absorber wall and the carrier structure that receives the heat transfer tubes, or as a heat transfer component fitted into the absorber tube, i.e., as a shaped piece that admits the heat transfer tubes in shape-closing fashion and replaces the carrier structure with the heat conduction plates.

[0019] In accordance with an added feature of the invention, the heat transfer tubes are U-shaped tubes, tubes through which a flow of the heat transmission medium moves from below upwards, coaxial heat transfer tubes, heat pipes or a combination thereof.

[0020] In accordance with another feature of the invention, a carrier structure is provided which houses the heat transfer tubes. The second side of the heat conduction element forms the form-locking connection with adjoining surfaces of at least one of the heat transfer tubes and the carrier structure.

[0021] In accordance with a further feature of the invention, the heat conduction element is a graphite foil, which is wound about the carrier structure that receives the heat transfer tubes, and adjoins the inner wall of the inner glass tube in the form-locking connection.

[0022] The graphite foil has a thickness between 0.1 and 1 mm, and a density between 0.5 and 1.5 g/cm³.

[0023] In accordance with an additional feature of the invention, the heat conduction element is a heat transfer component composed of two half-form shapes and the compressed graphite expandate in the heat conduction element has a density between 0.02 and 0.5 g/cm³.

[0024] In accordance with another further feature of the invention, an absorber layer is disposed on the first side of the heat conduction element that faces the inner wall of the inner glass tube.

[0025] In accordance with a concomitant feature of the invention, the heat transfer tubes are in the form-locking connection with the heat conduction element being a heat transfer component made of the compressed graphite expandate. A graphite foil is wound about the heat transfer component and the graphite foil adjoins the inner wall of the inner glass tube in a form-locking connection.

[0026] Other features which are considered as characteristic for the invention are set forth in the appended claims.

[0027] Although the invention is illustrated and described herein as embodied in vacuum tubes for solar collectors with improved heat transfer, it is nevertheless not intended to be limited to the details shown, since various modifications and

structural changes may be made therein without departing from the spirit of the invention and within the scope and range of equivalents of the claims.

[0028] The construction and method of operation of the invention, however, together with additional objects and advantages thereof will be best understood from the following description of specific embodiments when read in connection with the accompanying drawings.

BRIEF DESCRIPTION OF THE SEVERAL VIEWS OF THE DRAWING

[0029] FIG. 1 is a diagrammatic, cross-sectional view of a Sydney vacuum tube collector with heat conduction plates according to the prior art with a U tube for the heat transfer fluid;

[0030] FIG. 2 is a diagrammatic, cross-sectional view of a Sydney vacuum tube collector according to a first embodiment of the invention with an intermediate layer made of graphite foil;

[0031] FIG. 3 is a diagrammatic, cross-sectional view of a Sydney vacuum tube collector according to a second embodiment of the invention with a heat transmission component made of expanded graphite;

[0032] FIG. 4A is a diagrammatic, transverse sectional view of the Sydney vacuum tube according to a second embodiment of the invention with a coaxial tube embedded in the heat transmission component;

[0033] FIG. 4B is a diagrammatic, longitudinal sectional view of the Sydney vacuum tube according to a second embodiment of the invention with a coaxial tube embedded in the heat transmission component;

[0034] FIG. 5A is a diagrammatic, transverse sectional view of the Sydney vacuum tube according to the second embodiment of the invention with a heat pipe embedded in the heat transmission component;

[0035] FIG. 5B is a diagrammatic, longitudinal sectional view of the Sydney vacuum tube according to the second embodiment of the invention with a heat pipe embedded in the heat transmission component; and

[0036] FIG. 6 is a diagrammatic, cross-sectional view of an invention-specific heat transmission component with a modified cross section.

DETAILED DESCRIPTION OF THE INVENTION

[0037] Referring now to the figures of the drawing in detail and first, particularly, to FIGS. 2 and 3 thereof, there is shown two principal embodiments of the invention as examples using a Sydney collector with a U-shaped heat transfer pipe 5', 5", but they are not limited to that. Alternatively, the heat transfer fluid can also be brought through a coaxial tube or a tube that has flow going from below upwards, or a heat pipe is used.

[0038] In a first embodiment of the invention (FIG. 2) the carrier structure with the heat transfer tubes 5', 5" on its surface that faces the inner wall of absorber pipe 2 is wound about by graphite foil 9, which creates a form-fit, thermally conducting contact between absorber tube 2 and the heat transfer pipes 5', 5". The carrier structure itself is not shown in FIG. 2 for better clarity. Heat conduction plates are no longer needed here, so that the weight of the collector tubes is reduced.

[0039] From sealing technology it is known that graphite foil easily adapts to surfaces that are to be sealed, and thereby

compensates for unevenness or other irregularities in the surface of flanges. In the present invention, the graphite foil **9** exactly adapts to the adjoining surfaces of the carrier structure and the heat transfer tubes **5'**, **5''** on the one side, and to the inner wall of the inner glass tube **2** on the other side, and thus compensates for irregularities present in these surfaces. Heat transmission is thereby facilitated.

[0040] As regards thickness, a graphite foil is to be selected that on the one hand has sufficient stability against tearing, and on the other hand is sufficiently flexible so that it can be wound. Suitable graphite foil has a thickness between 0.1 and 1 mm, preferably up to 0.5 mm, and a density between 0.5 and 1.5 g per cm³.

[0041] In a further embodiment of the invention shown in FIGS. 3-5, the carrier structure made of heat conduction plates that receive the heat transfer tubes, is replaced by a shaped piece made of compressed graphite expandate. This is designated in what follows as the heat transmission component **10**. The invention-specific heat transmission components **10** have a generally cylindrical configuration with recesses to admit the heat transfer pipes **5'**, **5''**. The heat transmission component **10** has dimensions so that its circumferential surface is at least partially form-fitting on the inner wall of glass tube **2** (the absorber tube). The heat transfer tubes **5'**, **5''**, depicted as examples in FIG. 3 and U-tubes **5'**, **5''**, are in turn admitted in form-fitting fashion from the heat transmission component **10** made of compressed graphite expandate.

[0042] The heat transmission component **10** may be embodied as a one-piece shaped piece, but for reasons having to do with manufacturing technology, as shown in FIGS. 3-5, it preferably is composed of two half-shape pieces **10'** and **10''**.

[0043] The figures that follow show this same embodiment of the invention with other types of heat transfer pipes.

[0044] FIGS. 4A and 4B show a transverse and longitudinal section of a dual-wall glass tube **1**, **2**, in which the heat transfer fluid is brought through a coaxial pipe **5'''**. The coaxial pipe is embedded in form-fitting fashion between the two half-shape pieces **10'**, **10''**, whose surfaces that abut one another have matching recesses.

[0045] FIGS. 5A and 5B show a further alternative in transverse and longitudinal section of dual-walled glass tube **1**, **2**, in which the heat transfer fluid is brought through a heat pipe **5''''**. The heat pipe is embedded in form-fitting fashion between the two half-shape pieces **10'**, **10''**, whose surfaces that abut one another have matching recesses.

[0046] In the same way, a heat transfer pipe that has the flow coming through it from below upwards can be embedded in form-fitting fashion between the two half-shape pieces **10'**, **10''** that form the heat transfer component **10**, or combinations of various types of heat transfer pipes.

[0047] Graphite expandate is outstanding in having a high capacity to adapt to adjoining surfaces, thus assuring a form-fitting joint, and thus small heat transmission resistance, to the inner wall of the inner glass tube **2** on the one side, and to the heat transfer pipes on the other side. By this measure, heat transfer is facilitated, and heat transfer resistance drops.

[0048] In addition, due to the form-fitting of the heat transfer component **10** with the inner glass tube **2** and the heat transfer pipes, stability of the entire structure of the vacuum tubes is increased.

[0049] In addition, this invention-specific structure eliminates the problem of differing thermal expansions of copper

and aluminum. The heat transfer component **10**, made of compressed graphite expandate, possesses a compression reserve due to its porosity, so that the thermal expansion of the copper pipe can be compensated for.

[0050] A further advantage of this embodiment is that weight is reduced, since the shaped piece **10** made of compressed graphite expandate is considerably lighter than the traditional metal carrier structure.

[0051] Manufacture of graphite expandate and graphite foil is known. Graphite interstitial compounds (graphite salts) such as graphite hydrogen sulfate or graphite nitrate are given shock-type heating in an oven or by microwaves. The volume of the particles increases by a factor of 200 to 400, and the bulk density drops to 2 to 20 g/l. The graphite expandate thus obtained is formed of worm-shaped or accordion-shaped aggregates. During densification the individual aggregates hook together to form a solid mass, so that, without addition of binders, self-supporting surface formations, such as foils or ribbons, or shaped bodies like plates, can be manufactured.

[0052] Another method known from the state of the art for manufacture of three-dimensional shaped bodies made of graphite expandate relates in carrying out the thermal expansion of the graphite interstitial compound or of the graphite salt in an appropriately configured shaping tool. This is done while taking care that the shaping tool must permit gases to escape. Due to the expensive tool configuration, however, this method is not preferred for the manufacture of shaped pieces for the present invention.

[0053] In place of that, a method has proven itself, according to which first, graphite expandate, in a known manner, is compressed into a plate of appropriate thickness, typically between 5 and 50 mm, and blanks are cut out from this plate, which then can be compressed in a tool into the desired shape. The generally cylindrical shaped pieces can be a single piece or be formed by adjoining of two individual shaped pieces manufactured according to this method with each other.

[0054] The density of the graphite expandate in these shaped pieces is in a range between 0.02 and 0.5 g/cm³.

[0055] Alternatively, the shaped pieces can also be manufactured by shape extrusion from pre-manufactured plates.

[0056] If the heat transmission component is to be inserted into a vacuum tube already provided with heat transfer pipes, then recesses must be provided in the shaped piece to admit the heat transfer tubes or the heat pipe. Thanks to the fact that the compressed article is easy to form, the recesses can be indented without difficulty into the shaped piece or be cut out of it. The shaped piece is then pushed from its open end outward into the vacuum tube, whereby the heat transfer pipes glide into the recesses provided for them.

[0057] In another embodiment form of the invention, a complete component is manufactured, including the heat transfer tube and the heat transmission component compressed from graphite expandate. For this, the heat transfer tube is simply pressed into the shaped piece, which if necessary formed of two half-shape pieces placed against each other, or is embedded between the two half-shape pieces, so that it is admitted in interlocked fashion.

[0058] With a cylindrical heat transmission component that corresponds on its entire circumference to the inner dimensions of absorber tube **2**, the invention is implemented optimally due to the full-surface interlocking over the entire available interior wall surface of absorber tube **2**. Deviations are also conceivable in principle from the cylindrical form, for example by recesses or indentations on the round cross sec-

tion of the cylinder. In these areas there then exists no interlocking to the interior wall of the absorber tube, the full-surface interlocking is limited to the adjoining surfaces of the heat transmission component **10** with the inner wall of the absorber tube **2**. Ultimately it depends on the specific applied case, and the specialist must decide which cross section of the heat transmission component **10** to choose, whereby consideration is to be given to efficiency losses with a reduced contact surface between the heat transmission component **10** and the absorber tube **2** on the one hand, and to savings in material due to deviations from cylindrical shape on the other hand.

[0059] Since deviations from cylindrical shape are thus possible, in the context of this invention, shaped pieces “generally cylindrical in shape” are understood to be with a geometry that one can regard as derived from a cylinder so that its original round cross section is provided with indentations or recesses, so that the circumferential surface of this form corresponds to the circumferential surface of a cylinder only in limited areas. These areas form the adjoining surfaces between the heat transmission element **10** and the inner wall of the inner glass tube **2**, and at these adjoining surfaces the interlocking is full-surface.

[0060] FIG. 6 shows one example of such a shape that deviates from cylindrical form of shaped piece **10**, here with an embedded coaxial tube **5**”. The interlocking contact to absorber tube **2** (the outer tube **1** was left out of the illustration for the sake of simplicity) is, however, in these areas nearly full-surface due to the great capacity of the compressed graphite expandate to adapt.

[0061] The two invention-specific embodiments according to FIGS. 2 and 3—graphite foil **9** on the inner side of the absorber tube **2** and assumption of the heat transfer pipe in a shaped piece **10** made of compressed graphite expandate—can also be combined, so that the heat transfer tubes are admitted through a shaped piece **10** made of graphite expandate, that for its part is wound about by graphite foil **9**.

[0062] In yet another embodiment of the invention, instead of the surface of inner glass tube **2** that faces the vacuum gap, the surface of heat transmission component **10** that faces the inner wall of inner glass tube **2** can be provided with an absorber layer. This embodiment has an advantage in that there is no heat transmission through the glass wall of tube **2**.

[0063] For use in environments with strong insolation, such as in southern European or African countries, the absorption layer **7** can fully be dispensed with, and the absorption action of the graphite can be exploited. Efficiency losses implied with that can be compensated by cost reductions for materials and manufacture, which also favors their being used in poorer countries, of which many are located in parts of the earth with strong insolation.

[0064] A form-locking or form-fitting connection is one that connects two elements together due to the shape of the elements themselves, as opposed to a force-locking connection, which locks the elements together by force external to the elements.

1. A solar collector vacuum tube, comprising:

two glass tubes including an inner glass tube and an outer glass tube placed one inside another concentrically, each of said glass tubes being closed in a hemispheric shape at a first end, and fused to each other at a second end, said two glass tubes defining a gap there-between and said gap being evacuated;

pipes functioning as heat transfer tubes disposed in an interior space of said inner glass tube and through which a heat transmission medium flows; and

a heat conduction element disposed in said interior space of said inner glass tube and made of a compressed graphite expandate, said heat conduction element having a first side forming a form-locking connection with said interior wall of said inner glass tube and a second side forming a form-locking connection with adjoining surfaces of said heat transfer tubes.

2. The solar collector vacuum tube according to claim 1, wherein said heat transfer tubes are selected from the group consisting of U-shaped tubes, tubes through which a flow of the heat transmission medium moves from below upwards, coaxial heat transfer tubes, heat pipes and a combination thereof.

3. The solar collector vacuum tube according to claim 1, further comprising a carrier structure housing said heat transfer tubes, and said second side of said heat conduction element forming said form-locking connection with adjoining surfaces of at least one of said heat transfer tubes and said carrier structure.

4. The solar collector vacuum tube according to claim 3, wherein said heat conduction element is a graphite foil, which is wound about said carrier structure that receives said heat transfer tubes, and adjoins said inner wall of said inner glass tube in said form-locking connection.

5. The solar collector vacuum tube according to claim 4, wherein said graphite foil has a thickness between 0.1 and 1 mm, and a density between 0.5 and 1.5 g/cm³.

6. The solar collector vacuum tube according to claim 1, wherein said heat transfer tubes are held in said form-locking connection in said heat conduction element made of said compressed graphite expandate, said heat conduction element forming said form-locking connection with said inner wall of said inner glass tube.

7. The solar collector vacuum tube according to claim 6, wherein said heat conduction element is a heat transfer component composed of two half-form shapes.

8. The solar collector vacuum tube according to claim 6, wherein said compressed graphite expandate in said heat conduction element has a density between 0.02 and 0.5 g/cm³.

9. The solar collector vacuum tube according to claim 6, further comprising an absorber layer disposed on said first side of said heat conduction element that faces said inner wall of said inner glass tube.

10. The solar collector vacuum tube according to claim 1, wherein said heat transfer tubes are in said form-locking connection with said heat conduction element being a heat transfer component made of said compressed graphite expandate; and

further comprising a graphite foil wound about said heat transfer component and said graphite foil adjoining said inner wall of said inner glass tube in a form-locking connection.

11. A heat transfer component for a vacuum-tube solar collector having an inner glass tube with an inner wall, the heat transfer component comprising:

a generally cylindrical shaped piece made of compressed graphite expandate for holding heat transfer tubes in a form-locking manner, and having a circumferential surface forming a form-locking connection with the inner wall of the inner glass tube.

12. The heat transfer component according to claim **11**, wherein said shaped piece has recesses formed therein for receiving the heat transfer tubes in the form-locking manner.

13. The heat transfer component according to claim **11**, wherein the heat transfer tubes are embedded in the form-locking manner in said shaped piece.

14. The heat transfer component according to claim **11**, wherein said shaped piece is formed of two half-form pieces.

15. The heat transfer component according to claim **11**, wherein said graphite expandate has a density between 0.02 and 0.5 g/cm³.

16. The heat transfer component according to claim **11**, further comprising an absorber layer disposed on said circumference surface that faces the inner wall of the inner glass tube.

17. A method of using compressed graphite expandate for heat transmission, which comprises the step of:
placing the compressed graphite expandate in vacuum-tube solar collectors for performing heat transmission functions.

* * * * *