

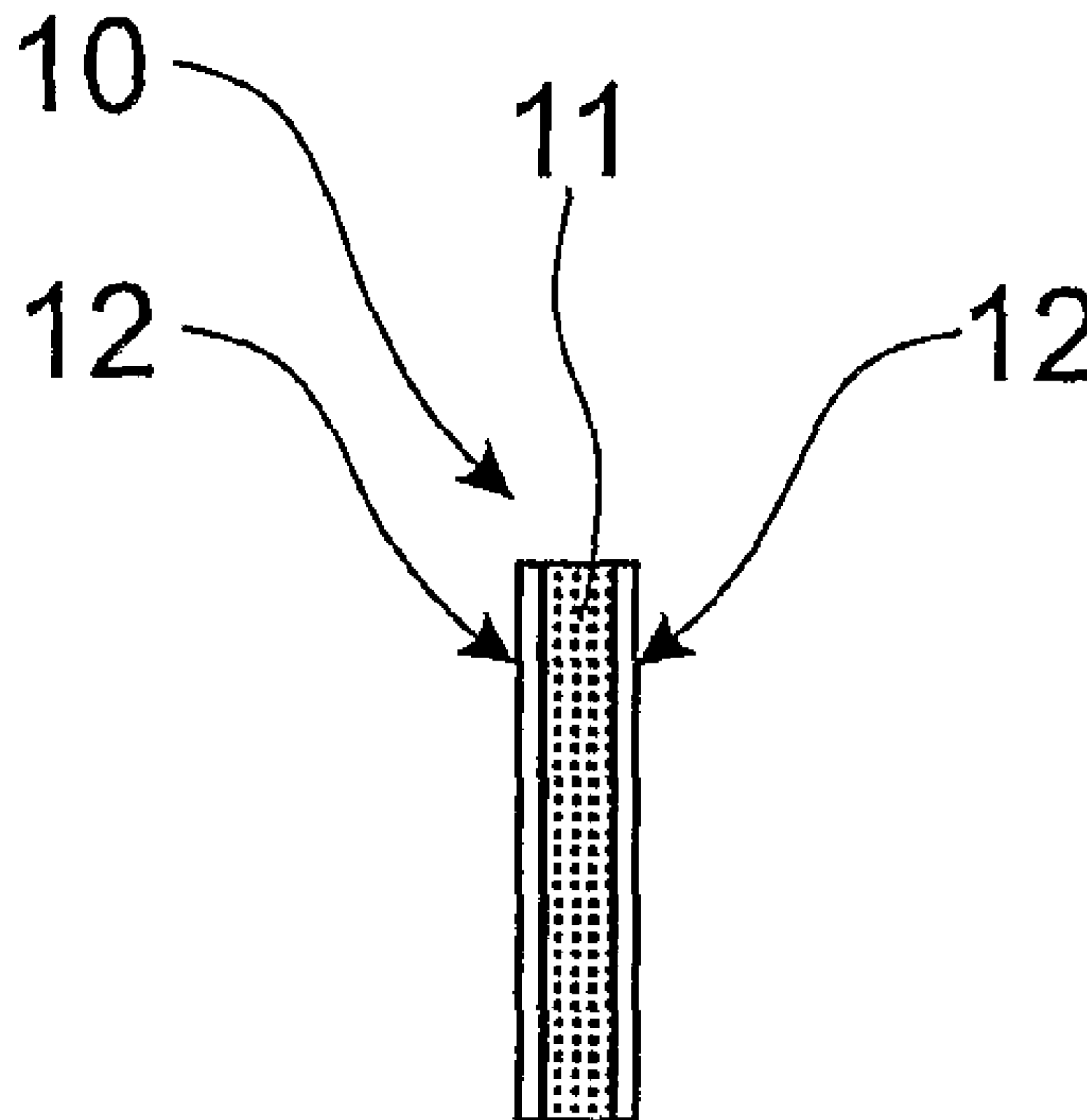

(86) Date de dépôt PCT/PCT Filing Date: 2006/07/26
(87) Date publication PCT/PCT Publication Date: 2007/02/01
(85) Entrée phase nationale/National Entry: 2008/01/25
(86) N° demande PCT/PCT Application No.: AU 2006/001052
(87) N° publication PCT/PCT Publication No.: 2007/012127
(30) Priorité/Priority: 2005/07/26 (AU2005903962)

(51) Cl.Int./Int.Cl. *E04C 2/10* (2006.01),
E04C 2/24 (2006.01), *E04C 2/26* (2006.01),
E04C 2/38 (2006.01)
(71) Demandeur/Applicant:
LOC COMPOSITES PTY LTD., AU
(72) Inventeur/Inventor:
BROWNE, DARREN JAMES, AU
(74) Agent: TORYS LLP

(54) Titre : ELEMENTS STRUCTURAUX CONSTITUES DE PANNEAUX SANDWICH A MOUSSE SYNTACTIQUE
(54) Title: STRUCTURAL ELEMENTS MADE FROM SYNTACTIC FOAM SANDWICH PANELS



(57) Abrégé/Abstract:

A structural member comprising at least one syntactic foam sandwich panel; the sandwich panel having a syntactic foam core and at least one skin; and at least one reinforcement element attached to the sandwich panel.



(12) INTERNATIONAL APPLICATION PUBLISHED UNDER THE PATENT COOPERATION TREATY (PCT)

(19) World Intellectual Property Organization
International Bureau(43) International Publication Date
1 February 2007 (01.02.2007)

PCT

(10) International Publication Number
WO 2007/012127 A3

(51) International Patent Classification:

E04C 2/10 (2006.01) *E04C 2/24* (2006.01)
E04C 2/26 (2006.01) *E04C 2/38* (2006.01)

(21) International Application Number:

PCT/AU2006/001052

(22) International Filing Date: 26 July 2006 (26.07.2006)

(25) Filing Language: English

(26) Publication Language: English

(30) Priority Data:

2005903962 26 July 2005 (26.07.2005) AU

(71) Applicant (for all designated States except US): **CORE-DEV PTY LTD** [AU/AU]; 16 John Street, Cambooya, Queensland 4350 (AU).

(72) Inventor; and

(75) Inventor/Applicant (for US only): **BROWNE, Darren James** [AU/AU]; 3 Banyula Drive, Toowoomba, Queensland 4350 (AU).(74) Agent: **FISHER ADAMS KELLY**; Level 29 Comalco Place, 12 Creek Street, Brisbane, Queensland 4000 (AU).

(81) Designated States (unless otherwise indicated, for every kind of national protection available): AE, AG, AL, AM, AT, AU, AZ, BA, BB, BG, BR, BW, BY, BZ, CA, CH, CN, CO, CR, CU, CZ, DE, DK, DM, DZ, EC, EE, EG, ES, FI, GB, GD, GE, GH, GM, HN, HR, HU, ID, IL, IN, IS, JP, KE, KG, KM, KN, KP, KR, KZ, LA, LC, LK, LR, LS, LT, LU, LV, LY, MA, MD, MG, MK, MN, MW, MX, MZ, NA, NG, NI, NO, NZ, OM, PG, PH, PL, PT, RO, RS, RU, SC, SD, SE, SG, SK, SL, SM, SY, TJ, TM, TN, TR, TT, TZ, UA, UG, US, UZ, VC, VN, ZA, ZM, ZW.

(84) Designated States (unless otherwise indicated, for every kind of regional protection available): ARIPO (BW, GH, GM, KE, LS, MW, MZ, NA, SD, SL, SZ, TZ, UG, ZM, ZW), Eurasian (AM, AZ, BY, KG, KZ, MD, RU, TJ, TM), European (AT, BE, BG, CH, CY, CZ, DE, DK, EE, ES, FI, FR, GB, GR, HU, IE, IS, IT, LT, LU, LV, MC, NL, PL, PT, RO, SE, SI, SK, TR), OAPI (BF, BJ, CF, CG, CI, CM, GA, GN, GQ, GW, ML, MR, NE, SN, TD, TG).

Published:

— with international search report

(88) Date of publication of the international search report:
19 April 2007

For two-letter codes and other abbreviations, refer to the "Guidance Notes on Codes and Abbreviations" appearing at the beginning of each regular issue of the PCT Gazette.

(54) Title: STRUCTURAL ELEMENTS MADE FROM SYNTACTIC FOAM SANDWICH PANELS

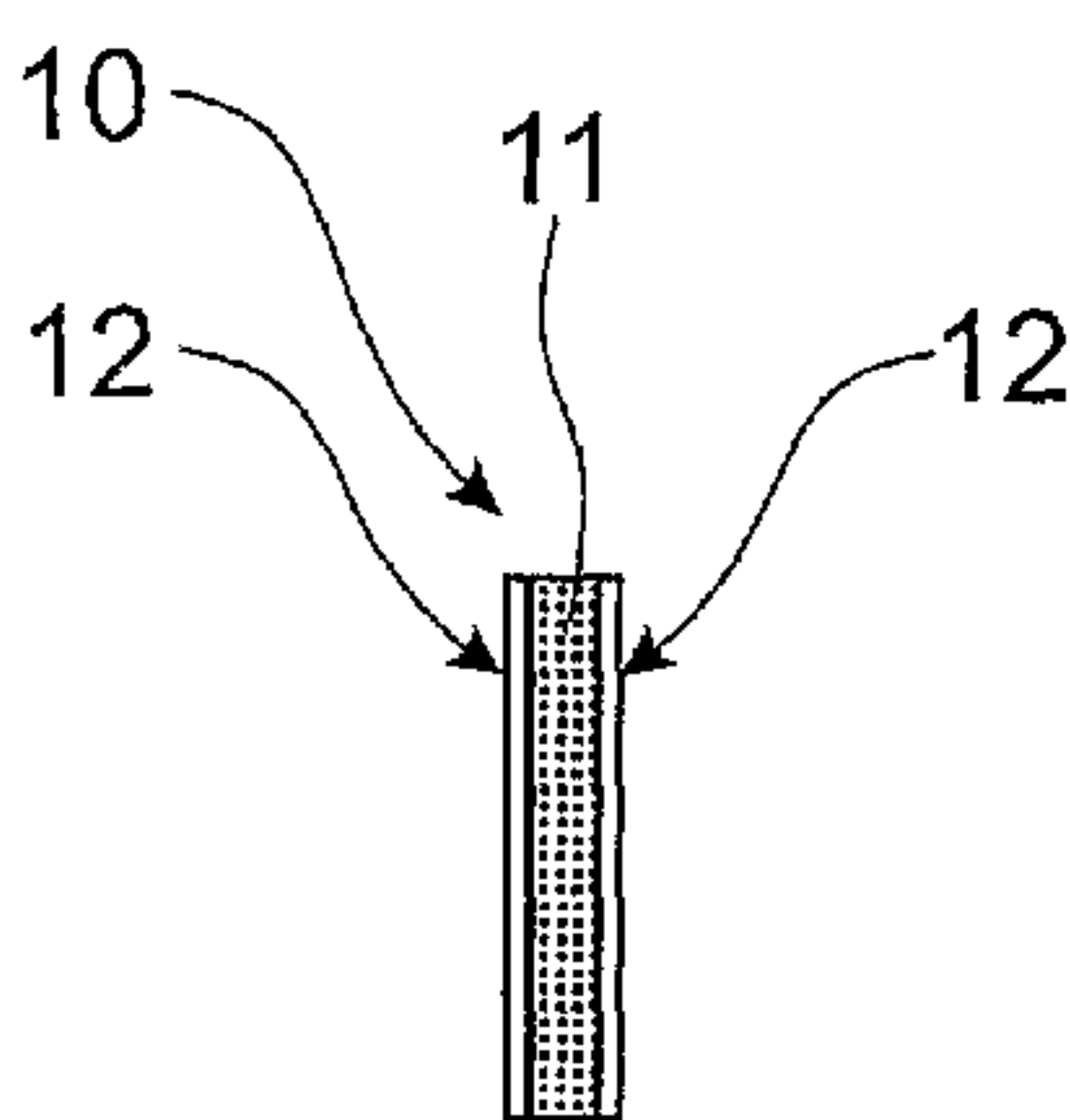

(57) Abstract: A structural member comprising at least one syntactic foam sandwich panel; the sandwich panel having a syntactic foam core and at least one skin; and at least one reinforcement element attached to the sandwich panel.

WO 2007/012127 A3

"STRUCTURAL ELEMENTS MADE FROM SYNTACTIC FOAM
SANDWICH PANELS"

FIELD OF THE INVENTION

5 This invention relates to a method of manufacturing structural elements.

BACKGROUND OF THE INVENTION

10 The superior structural properties of fibre reinforced polymer composites are well recognised. However, to date there have been difficulties with producing viable structural elements of fibre reinforced polymer composites due to cost constraints.

15 A popular approach to producing structural elements using fibre reinforced polymers has been through the use of the pultrusion process. However, the dies and machines needed to produce large structural elements with this method are very expensive. Further, many of the structures being produced require "one-off" construction and therefore are not economically produced using the pultrusion process.

20 It is well known from basic engineering mechanics that in most structural members under load there are areas in the member that are subjected to much higher internal stresses than other areas in the same member. For example in a beam loaded in uniform bending the material near the top and bottom of the beam are subjected to significantly higher bending stresses than material near the centre of the beam. Hence locating large amounts of expensive fibre composite material near the centre of such a beam is generally uneconomical. However, there is limited flexibility in the pultrusion process to incorporate other materials or to vary the orientation of the fibres.

25 In order to incorporate other materials and to optimize the fibre orientation in large structural elements many of them are made using alternative production methods such as hand-lay up or resin infusion methods. However, these methods require large moulds which are generally specific to a particular type of structural member. Hence, if another

30

structural element needs to be produced, another mould is required reducing cost effectiveness. Furthermore, the labour involved in these alternative manufacturing methods is quite significant leading to expensive products.

OBJECT OF THE INVENTION

5 It is an object of the invention to overcome and/or alleviate one or more of the above disadvantages or provide the consumer with a useful or commercial choice.

SUMMARY OF THE INVENTION

10 In one form, the invention resides in a structural member comprising:

a least one syntactic foam sandwich panel; the sandwich panel having a syntactic foam core and at least one skin; and

at least one reinforcement element attached to the sandwich panel.

15 The syntactic foam core may include microspheres made from polymeric materials such epoxy resin, unsaturated polyester resin, silicone resin, phenolics, polyvinyl alcohol, polyvinyl chloride, polypropylene, and polystyrene or from inorganic materials such as glass, silica-alumina ceramics or Cenospheres (hollow fly ash particles)

20 The skins of the syntactic foam sandwich panels may be made from fibre reinforced polymers. The fibres may be made from glass, carbon, Kevlar, thermoplastics or combinations thereof. The polymer may be made of polyester, vinylester, epoxy, polyurethane, thermoplastics or combination thereof. Preferably the polymer used in the skins is the same as that used in the syntactic foam. More preferably the syntactic foam sandwich panel is
25 produced in single manufacturing process, in this way a strong primary bond can be created between the skins and the syntactic foam core.

30 The reinforcement elements may be made from steel, concrete, timber, fibre reinforced polymers or any other material. An adhesive is typically used to adhere the syntactic foam sandwich panels to the reinforcement elements.

If the reinforcement elements are made from fibre reinforced polymers, then the fibres may be made from glass, carbon, Kevlar,

thermoplastic or combinations thereof and the polymer may be made of polyester, vinylester, epoxy, polyurethane, thermoplastic resins or combinations thereof.

5 One or more tie elements may span across the adhesive in order to avoid delamination of the adhesive and provide the assembly with robustness. The tie elements may be made from steel, concrete, timber, fibre reinforced polymers or any other material. The tie elements might also act as a reinforcement element.

10 The structural elements may include bulkheads, diaphragms, strong points and/or internal ties.

In one form, though not the only or broadest form, the invention resides in a method of producing an improved structural element, said method including the steps of:

15 obtaining at least one syntactic foam sandwich panel;
obtaining at least one reinforcement element; and
joining the at least one syntactic foam sandwich panel and reinforcement element to form the improved structural element.

The structural elements produced using this method may be used in conjunction with each other to produce improved structures.

20 BRIEF DESCRIPTION OF THE DRAWINGS

Embodiments of the invention will be described with reference to the accompanying drawings in which:

FIG 1A is a side view of a syntactic foam sandwich panel;

25 FIG 1B is a transverse cross sectional view of the sandwich panel according to FIG 1A;

FIG 2 is a transverse cross sectional view of a structural element according to a first embodiment of the invention;

FIG 3 is a transverse cross sectional view of a structural element according to a second embodiment of the invention;

30 FIG 4 is a transverse cross sectional view of a structural element according to a fourth embodiment of the invention;

FIG 5 is a transverse cross sectional view of a structural element

according to a fourth embodiment of the invention;

FIG 6 is a transverse cross sectional view of a structural element according to a fifth embodiment of the invention;

5 FIG 7 is a transverse cross sectional view of a structural element according to a sixth embodiment of the invention;

FIG 8 is a transverse cross sectional view of a structural element according to a seventh embodiment of the invention;

FIG 9 is a transverse cross sectional view of a structural element according to an eighth embodiment of the invention;

10 FIG 10 is a transverse cross sectional view of a structural element according to a ninth embodiment of the invention;

FIG 11 is a transverse cross sectional view of a structural element according to a tenth embodiment of the invention;

15 FIG 12 is a side view of a reinforcement system that incorporates a number of bulkheads;

FIG 13 shows a perspective view of a structural element according to an eleventh embodiment of the invention;

FIG 14 shows a transverse cross sectional view of a structural element according to a twelfth embodiment of the invention;

20 FIG 15A shows a perspective of a pedestrian bridge which has been produced by combining structural elements according to the invention;

FIG 15B shows an end view of the same pedestrian bridge.

25 FIG 16 shows a transverse cross sectional view of a road bridge which has been produced by combining structural elements according to the present invention.

DETAILED DESCRIPTION OF THE PREFERRED EMBODIMENT

30 FIGS 1A and FIG 1B shows a sandwich panel 10 used to produce structural elements as shown in FIGS 2 to 16. The sandwich panel has a syntactic foam core 11 and two fibre reinforced polymer skins 12. The syntactic foam core in this embodiment is made from epoxy resin with Cenospheres and expanded polystyrene bead fillers. It should be appreciated that the materials used to produce the syntactic foam core may

be varied to specified need of a structural element. The reinforced polymer skins are made from glass fibre and epoxy resin. It should be appreciated that the syntactic fibre reinforced polymer skins may be also made from other materials depending on the structural requirements of a structural member.

FIG 2 shows a cross section of structural member 20 that consists of a syntactic foam panel 10 having two reinforcing elements in the form of two steel reinforcement strips 21. The two steel reinforcement strips 21 are substantially rectangular in transverse cross section.

In order to produce the structural member 20, two grooves are cut in the syntactic foam core 11 of the syntactic panel 10. Adhesive is then placed on the two steel reinforcement strips 21 and the two steel reinforcement strips 21 are located within the grooves to contact the syntactic foam core. The two steel reinforcement strips 21 increase the strength and stiffness.

FIG 3 shows a cross section of a beam 30 having a syntactic foam panel 10 and two reinforcing elements in the form of two fibre reinforced polymer reinforcement strips 31. The two fibre reinforced polymer reinforcement strips 31 have fibres that are made from carbon and the polymer is epoxy resin.

The beam shown in FIG 3 is produced by applying adhesive on the two fibre reinforced polymer reinforcement strips 31. The two fibre reinforced polymer reinforcement strips 31 are the placed on respective ends of the sandwich panel to complete the beam 30. The beam has improved strength and stiffness.

FIG 4 shows a cross section of a beam 40 including a sandwich panel 10 and two reinforcement elements in the form of two fibre reinforced polymer U-shape sections 41. The two fibre reinforced polymer U-shape sections 41 are made from pultruded polyester-glass fibre composites that are relatively inexpensive to manufacture.

The beam 40 is manufactured by applying adhesive to the two fibre reinforced polymer U-shape sections 41 and placing the two fibre

reinforced polymer U-shape sections 41 over respective ends of the sandwich panel. Due to the shape of the fibre reinforced polymer U-shape sections 41, the contact area between the reinforcement modules and the syntactic foam panel 10 is significantly increased compared to the fibre reinforced polymer reinforcement strips 31 in FIG 3. This results in significantly increased resistance against delamination of the two fibre reinforced polymer U-shape sections 41 from the sandwich panel 10. Further, the two fibre reinforced polymer U-shape sections 41 also contact two fibre reinforced polymer skins 12. The strength of the bond between the fibre reinforced skins 12 and fibre reinforced polymer U-shape sections 41 is high compared to the bond formed between the syntactic foam core 11 and the fibre reinforced polymer U-shape sections 41. This also assists in reducing the risk of delamination of the syntactic foam sandwich panel 10 U-shape sections 41 from the sandwich panel 10.

FIG 5 shows a beam 50 that is a variation of beam of FIG 4. In this embodiment filler elements 51 in the form of epoxy resin and Cenospheres are located between the two fibre reinforced polymer U-shape sections 41 adjacent the two fibre reinforced polymer skins 12.

FIG 6 shows a beam 60 that is a variation of the beam 50 that is shown in FIG 5. The beam 60 replaced the single syntactic foam sandwich beam 10 with two half-width syntactic foam sandwich panels 15.

FIG 7 shows a beam 70 produced using a syntactic foam sandwich panel 10, a top reinforcement element in the form of a polymer concrete flange 71 and a bottom reinforcement panel in the form of a pultruded polyester-glass fibre composite U-shape section 72. Adhesive is again used to adhere the polymer concrete flange and the pultruded polyester-glass fibre composite U-shape section 72 to the syntactic foam sandwich panel 10.

FIG 8 shows a transverse cross section of a hollow beam 80 that is formed from four syntactic foam panels 10 and two reinforcement elements in the form of two pultruded fibre reinforced polymer square sections 81.

To produce the hollow beam 80, the four syntactic foam panels 10 are adhered to the two pultruded fibre reinforced polymer square sections 81. The two pultruded fibre reinforced polymer square sections 81. The square reinforcement elements have large planar surfaces which bond strongly to the two fibre reinforced polymer skins 12. The structural member of FIG 8 can be provided with additional bulkheads in the space between the two reinforcement elements as shown in FIG 12. The vertical elements 82 in FIG 12 can be made of sections of syntactic foam panels 10 or the sections of the pultruded fibre reinforced polymer square sections 81.

FIG 9 shows a transverse cross section of a hollow beam 90 made from four syntactic foam sandwich panels 10 and reinforcement elements in the form of four angle sections 91. The angle sections 91 are made of steel. The hollow beam is formed by adhering the four syntactic foam sandwich panels together and adhering the four angle sections in respective corners. The angle sections provide the hollow beam with reinforced corners. The hollow beam may be provided with bulkheads as shown in FIG 12.

FIG 10 shows a larger hollow beam 100 that consists of three syntactic foam panels 10 and two different types of reinforcement elements. The first reinforcement element is in the form of two fibre reinforced polymer U-shape sections 101 whilst the second reinforcement element is in the form of four pultruded fibre reinforced polymer square sections 102. The two fibre reinforced polymer U-shape sections 101 are made of glass fibre reinforced phenolic resin whilst the four pultruded fibre reinforced polymer square sections 102 are made of carbon fibre reinforced vinyl ester resin.

The hollow beam 100 is manufactured by using adhering the four pultruded fibre reinforced polymer square sections 102 and the syntactic foam panels 10 are together using an epoxy adhesive. The fibre reinforced polymer U-shape sections 101 are then adhered to the syntactic foam panels 10 using the phenolic resin. The space between the reinforcement modules 92 can be provided with bulkheads as shown in FIG 12 as is required.

FIG 11 shows a hollow beam 110 that is a variation of beam

100 shown in FIG 10. The hollow beam 110 has a top first reinforcement member in the form of a polymer concrete member 111 that replaces the top fibre reinforced polymer U-shape sections 101. The polymer concrete member 111 combines good compression capacity with excellent durability.

5 FIG 13 shows a solid beam 120 having a syntactic foam sandwich panel 10 and a reinforcement element in the form of a layer of polymer concrete 121. The polymer concrete layer 121 provides the sandwich panel with improved wear resistance and compression capacity.

10 FIG 14 shows a solid beam 130 consisting of two syntactic foam sandwich panels 10 and a reinforcement element in the form of a layer of standard concrete 131.

The solid beam 130 is formed by adhering the two syntactic foam sandwich panels 10 together using an epoxy adhesive. The top of the double syntactic foam sandwich panel is provided with an aggregate interface 132. The aggregate interface 133 is made of aggregate having an average size of 10mm and is adhered to a top fibre reinforced polymer skin 12 of the syntactic foam sandwich panel 10 with epoxy adhesive. The layer of standard concrete 131 is then laid directly onto the aggregate interface. The concrete layer is approximately 150mm thick. During the casting of the standard concrete, the syntactic foam panels act as formwork and support the wet concrete. Once the concrete has cured the syntactic foam sandwich panels act as external fibre composite reinforcement for the concrete. This aggregate interface 133 provides an excellent bonding surface for the layer of polymer concrete 132 to prevent delamination of the layer of standard concrete 132 from the top of the syntactic foam sandwich panel 10.

25 FIG 15A and FIG 15B show an example of a pedestrian bridge consisting of structural elements produced using the current method, which have been used in conjunction with each other to produce improved structures. The bridge has multiple deck planks 135 which are made of the structural element shown in FIG 13. The longitudinal bridge beams 140 are made of the structural element shown in FIG 10. The posts 150 are made from the structural element shown in FIG 9. The rails of the hand rails 160

are made from the structural element shown in FIG 6.

FIG 16 shows an example of a road bridge consisting of structural elements produced using the current method, which have been used in conjunction with each other to produce improved structures. The bridge beams 170 are made using the principles of the structural element shown in FIG 11. The concrete deck 180 is reinforced using the principle of the structural element shown in FIG14. The bottom flange of the bridge beams are tied together using a syntactic foam sandwich panel 190 which is adhered to the beams.

FIG 17 shows another embodiment of a road bridge 200 that consists of five syntactic foam panel beams 210 interlinked by a syntactic foam sandwich panel deck 220. The five syntactic foam panel beams 210 are adhered to the syntactic foam sandwich panel deck 220. Each syntactic foam panel beam 210 includes six syntactic foam panels 211 with adhered reinforcement in the form of nineteen pultruded fibre reinforced polymer square sections 212. Each of the reinforcement sections are made of glass fibre reinforced epoxy resin. Most of the pultruded fibre reinforced polymer square sections 212A are filled with polymer concrete. Some of the pultruded fibre reinforced polymer square sections 212B are filled with a steel reinforcement bar and polymer concrete. The syntactic foam sandwich panel deck 220 is made from six syntactic foam panels 221 adhered together.

The properties of these structural elements such as stiffness, strength and mass can be tailored to specific applications by selection of the materials and dimensions of the syntactic foam sandwich panels and reinforcement elements.

It should be appreciated that various other changes and modifications may be made to the embodiments described without departing from the spirit or scope of the invention.

CLAIMS:

1. A structural member comprising:
at least one syntactic foam sandwich panel; the sandwich panel having a syntactic foam core and at least one skin; and
5 at least one reinforcement element attached to the sandwich panel.
2. The structural member of claim 1 wherein the reinforcement element is made from a section of steel, concrete, timber, fibre reinforced polymers.
3. The structural member of claim 1 wherein an adhesive is used to adhere the at least one syntactic foam sandwich panel to the at least one
10 reinforcement element.
4. The structural member of claim 1 wherein tie elements that span across the glue joints in order to avoid delamination of the adhesive and provide the assembly with robustness. The tie elements may be made from steel, concrete, timber, fibre reinforced polymers or any other material. The
15 tie elements might also act as a reinforcement element.
5. The structural member of claim 1 wherein the at least one reinforcement element is made from fibre reinforced polymers, the fibre being selected from glass, carbon, Kevlar, thermoplastic fibres or combinations therefore and the polymer selected from polyester, vinylester,
20 epoxy, phenolic, polyurethane, thermoplastic resins or combinations thereof.
6. The structural member of claim 1 wherein the syntactic sandwich panel includes microspheres, the microspheres being selected from polymeric materials including epoxy resin, unsaturated polyester resin, silicone resin, phenolics, polyvinyl alcohol, polyvinyl chloride, polypropylene,
25 and polystyrene
7. The structural member of claim 1 wherein the syntactic sandwich panel includes microspheres, the microspheres being selected from inorganic materials such as glass, silica-alumina ceramics or Cenospheres (hollow fly ash particles).
- 30 8. The structural member of claim 1 wherein the syntactic sandwich panel include skins, the skins being made from fibre reinforced polymers, the fibres being selected from glass, carbon, Kevlar, thermoplastics or

combinations thereof and the polymer being selected from polyester, vinylester, epoxy, phenolic, polyurethane, thermoplastics or combination thereof.

5 9. The structural member of claim 1 wherein the skins includes a polymer and the syntactic foam uses a polymer, the polymers being the same.

10. The structural member of claim 1 wherein the syntactic foam sandwich panel is produced in single manufacturing process.

10 11. The structural elements may include bulkheads, diaphragms, strong points and/or internal ties.

12. A method of producing an improved structural element, said method including the steps of:

obtaining at least one syntactic foam sandwich panel;

obtaining at least one reinforcement element; and

15 joining the at least one syntactic foam sandwich panel and reinforcement element to form the improved structural element.

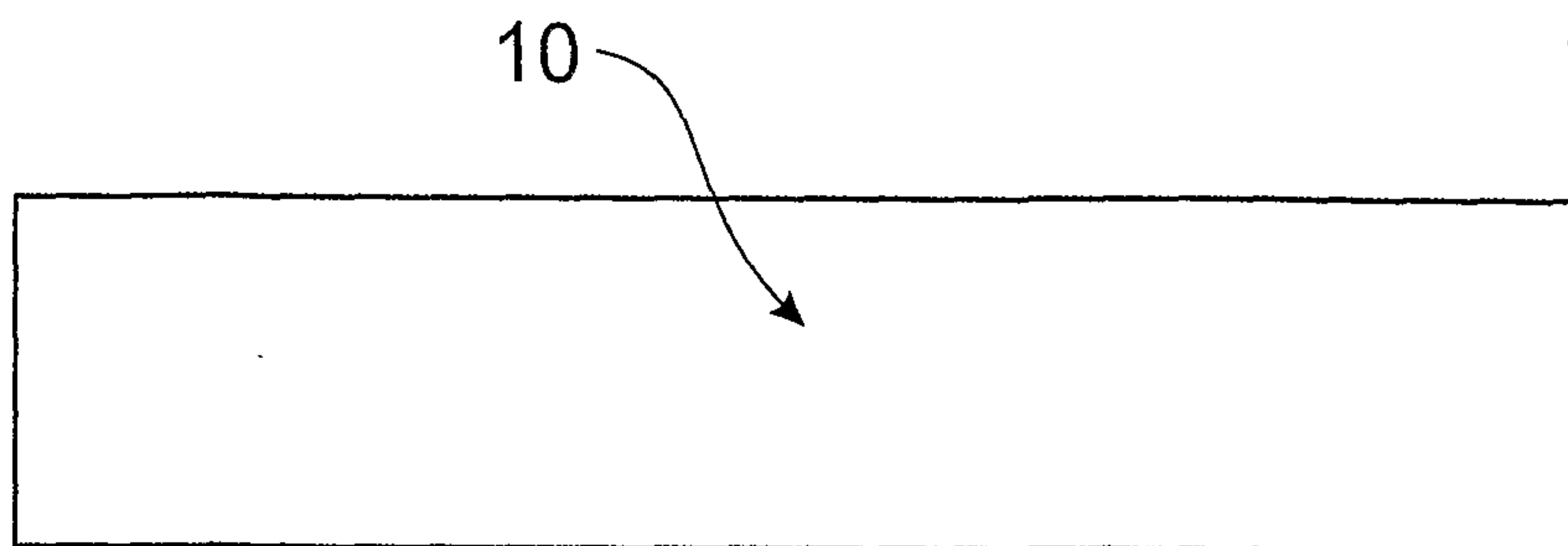

FIG. 1A

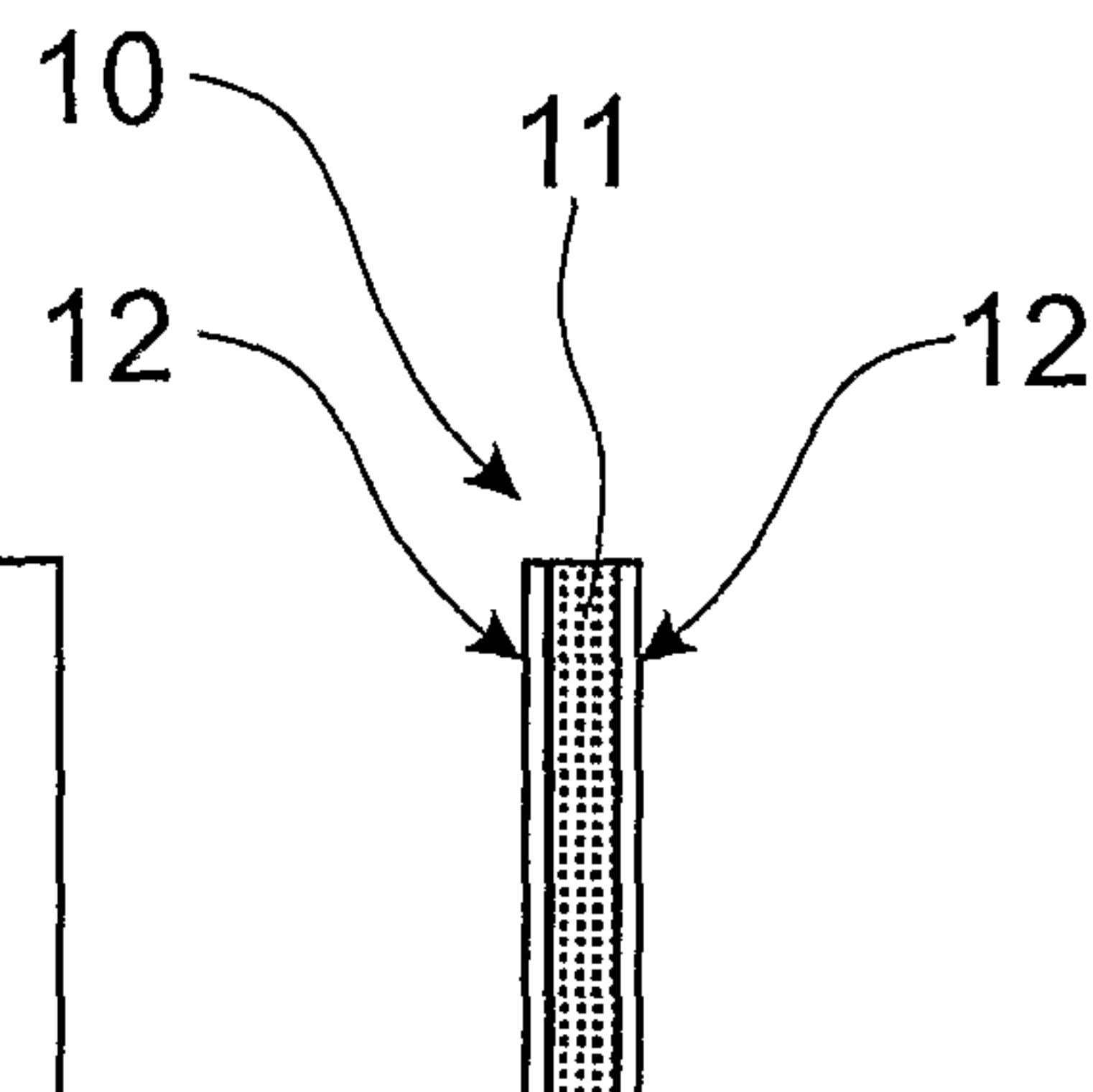

FIG. 1B

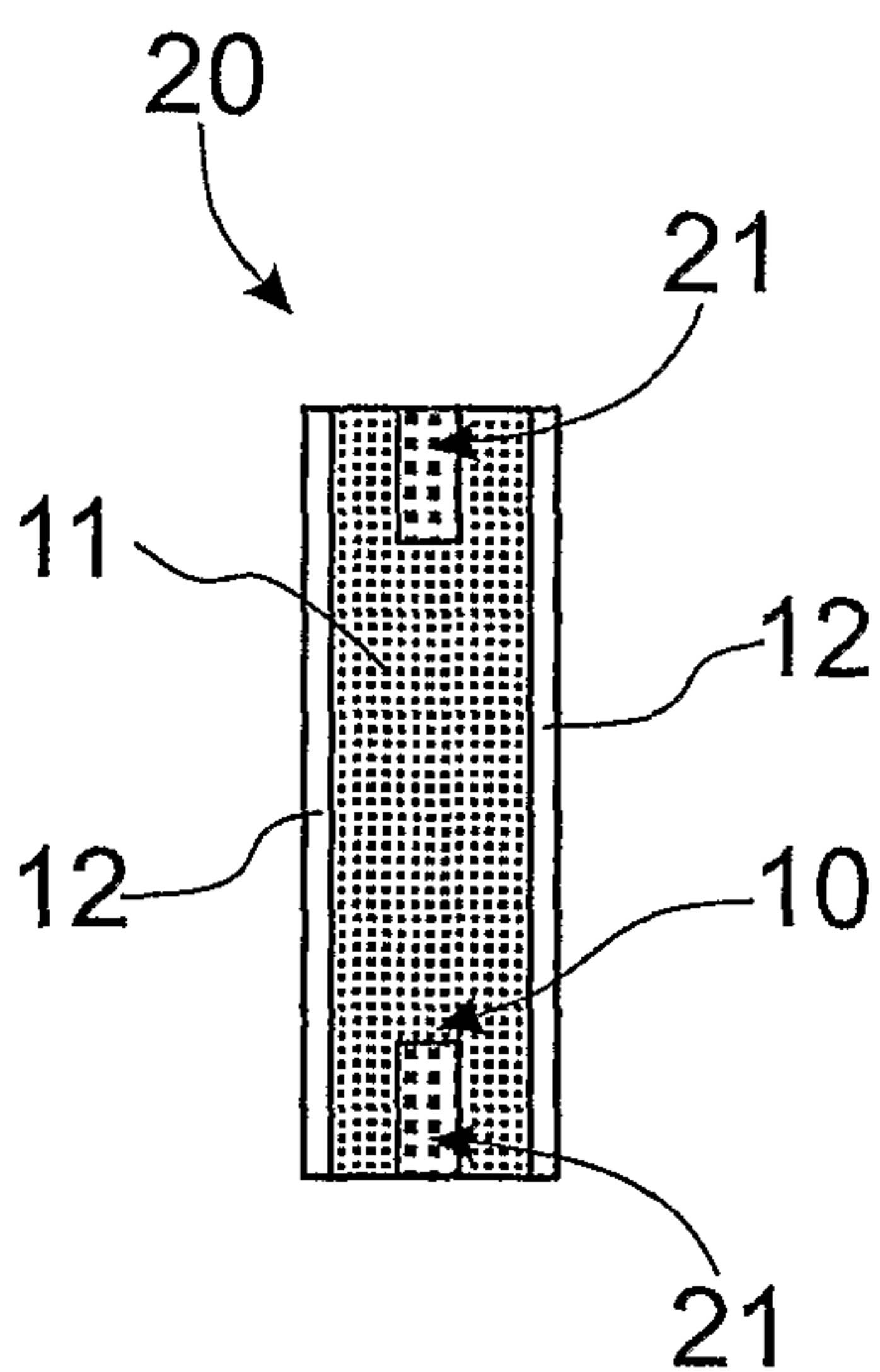

FIG. 2

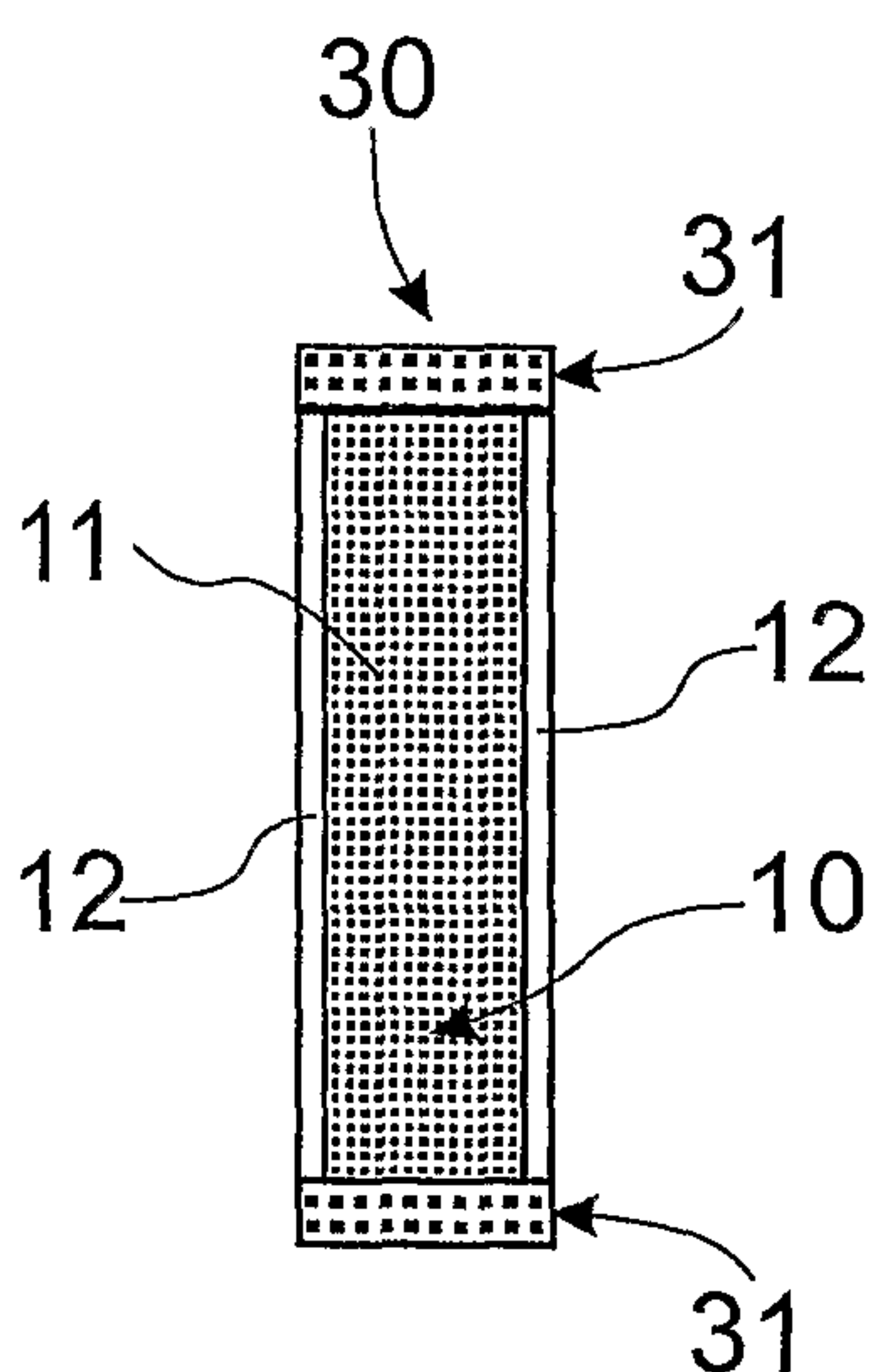

FIG. 3

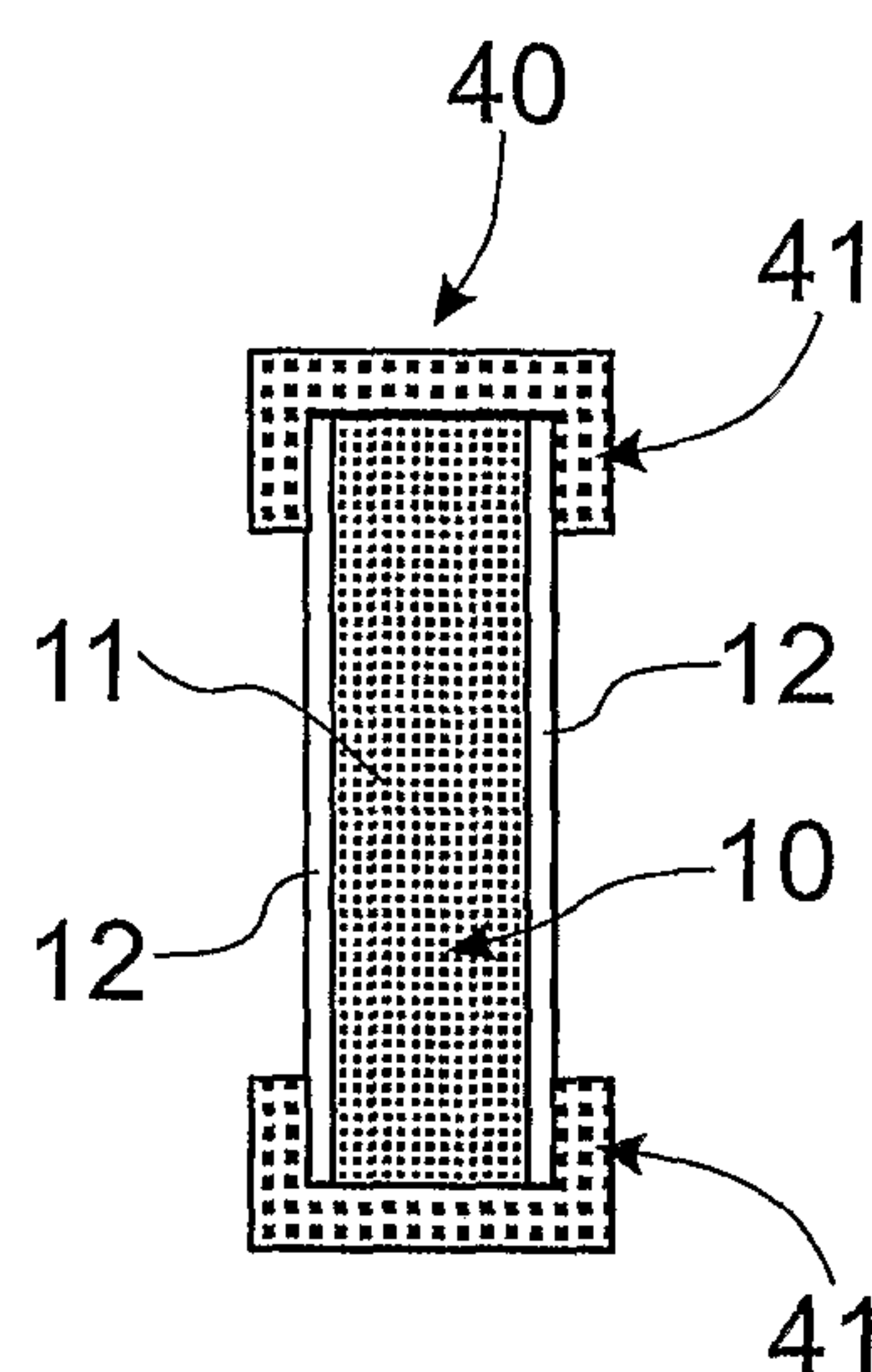

FIG. 4

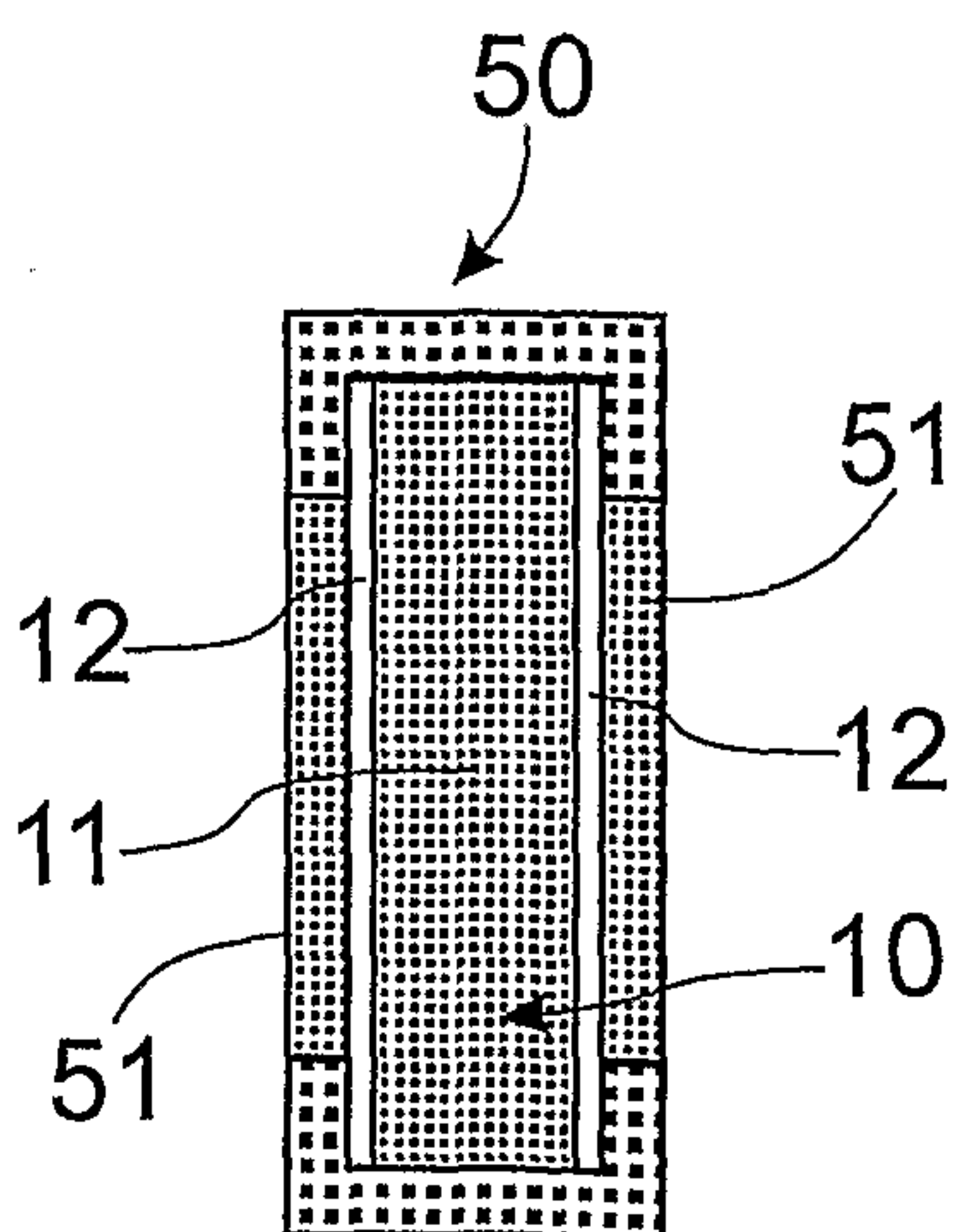

FIG. 5

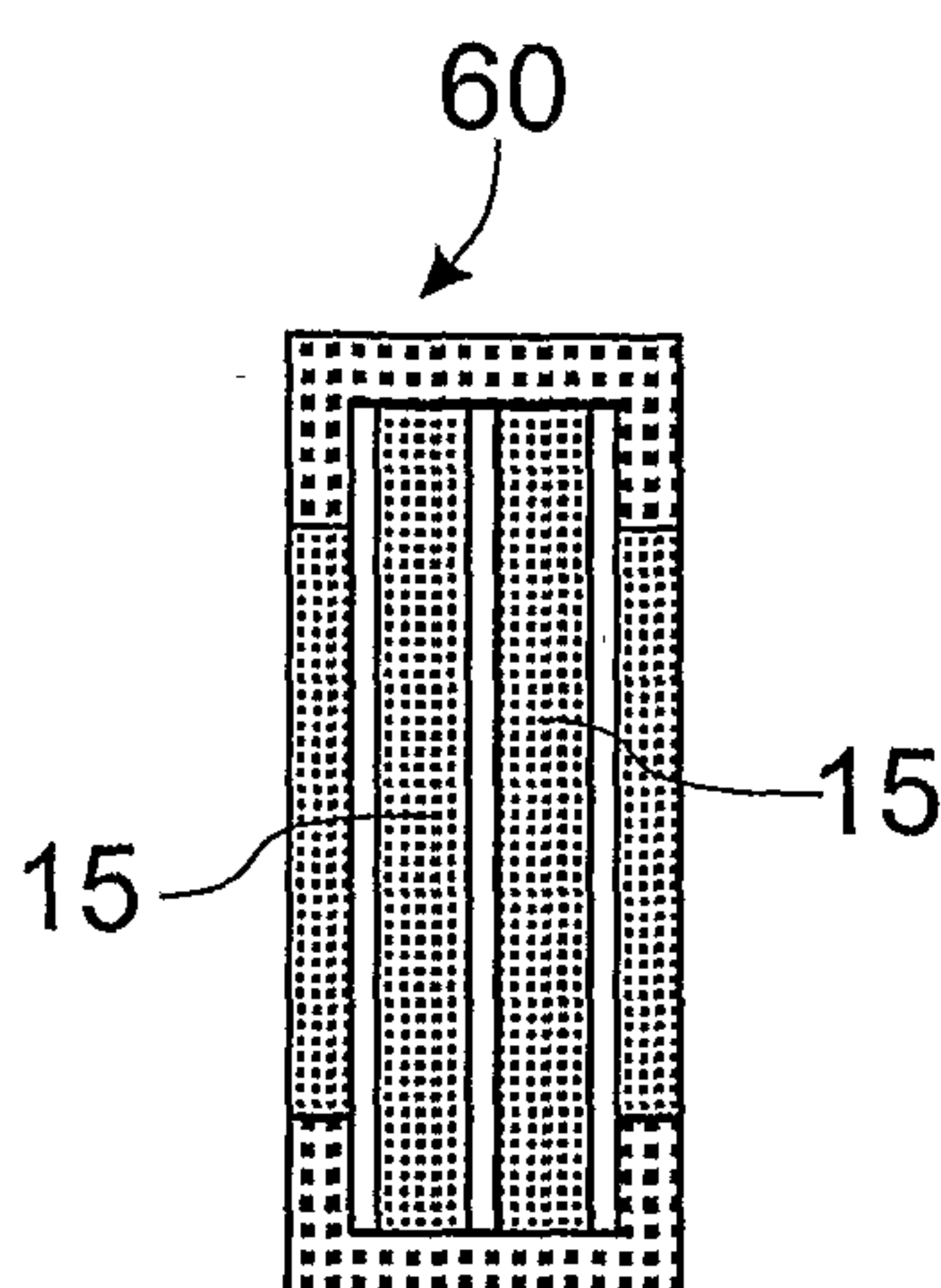

FIG. 6

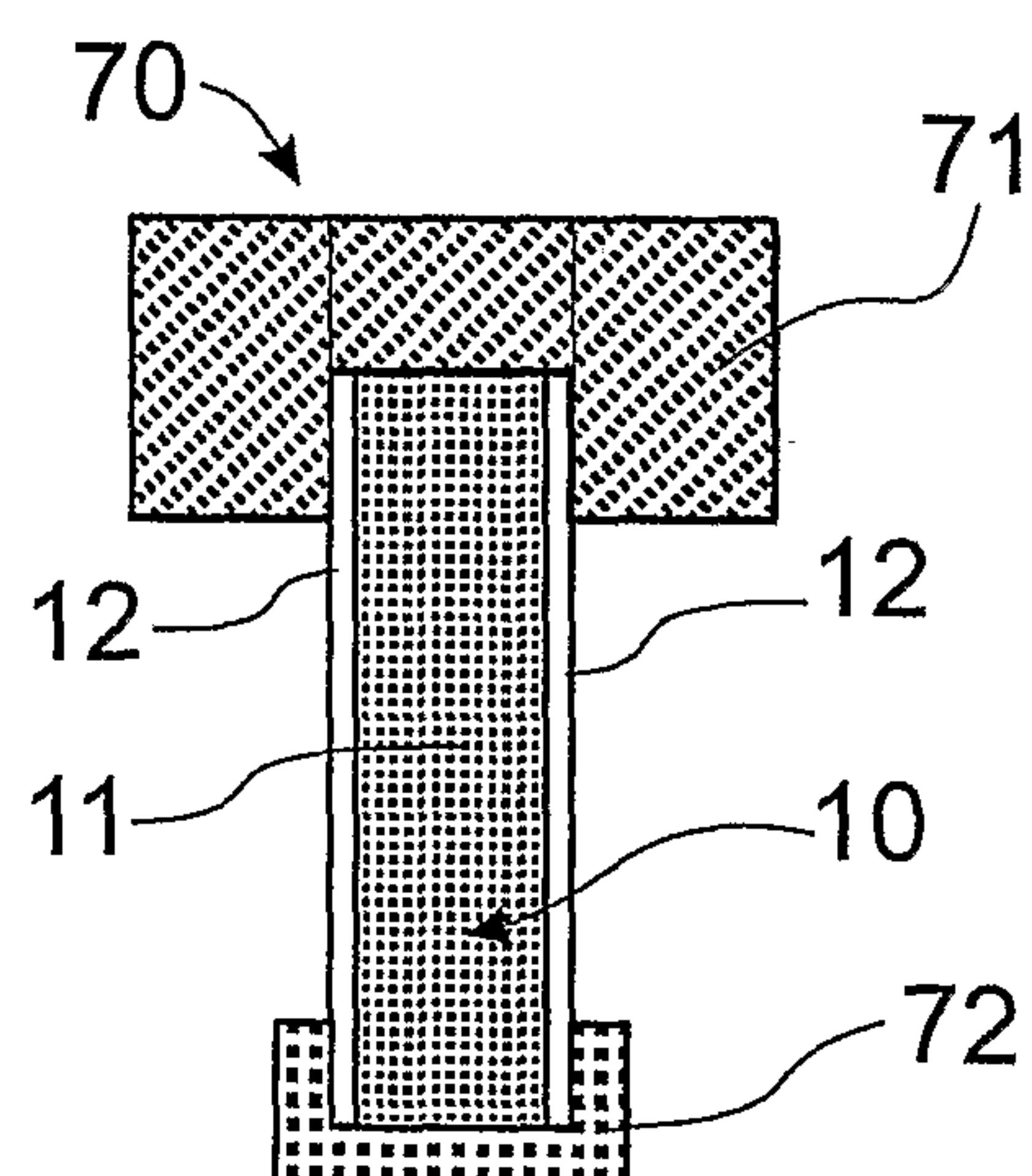

FIG. 7

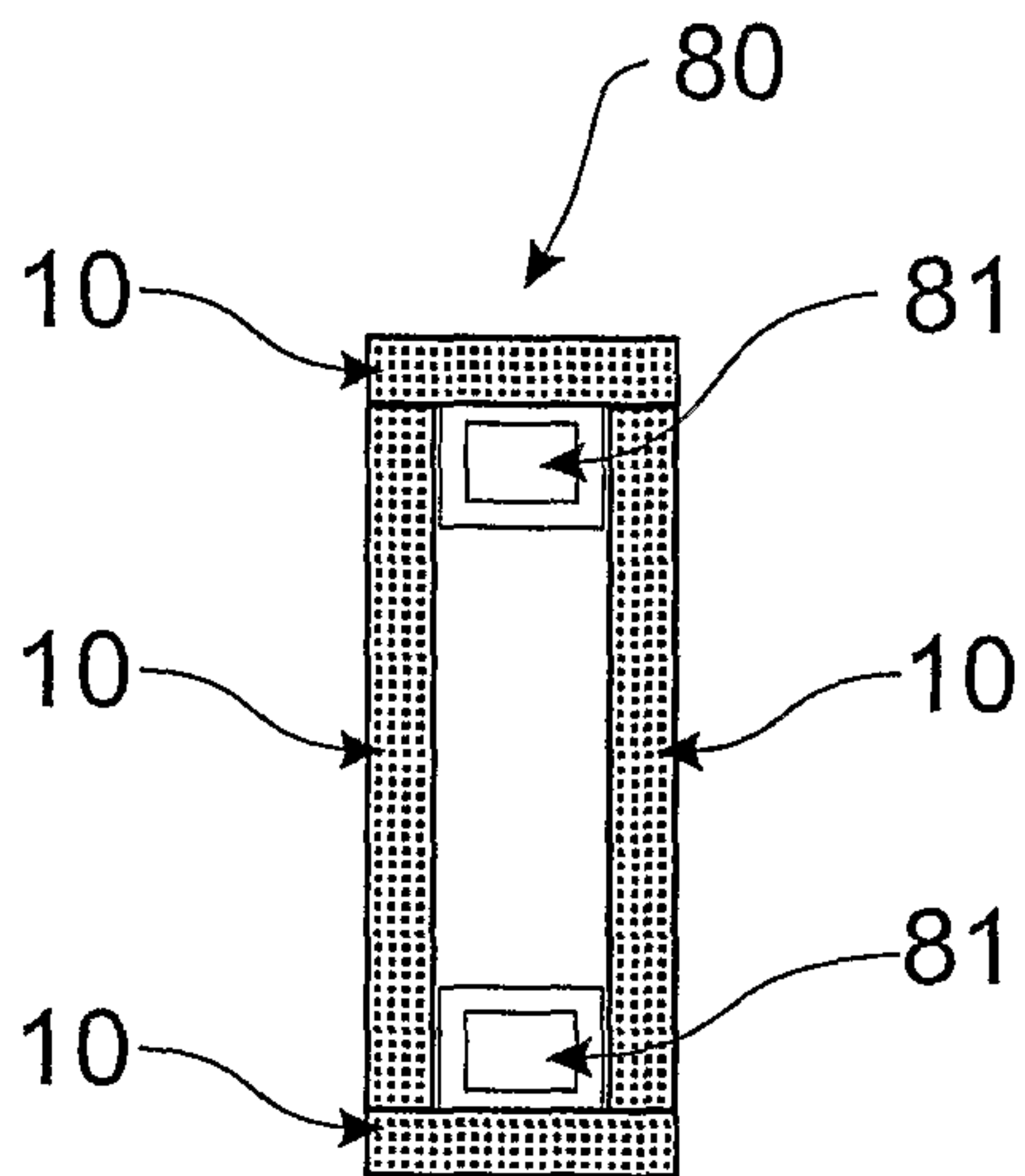

FIG. 8

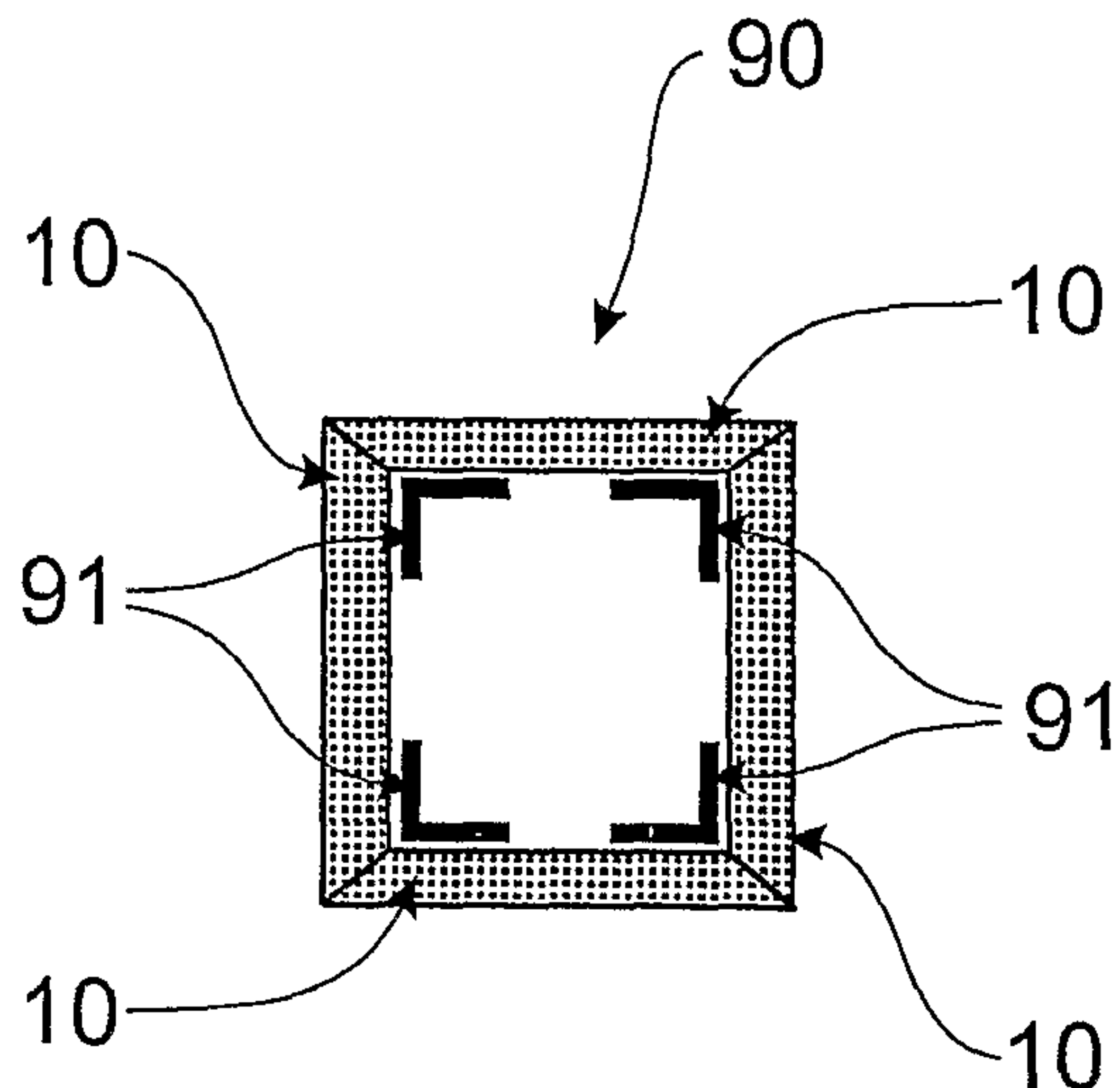

FIG. 9

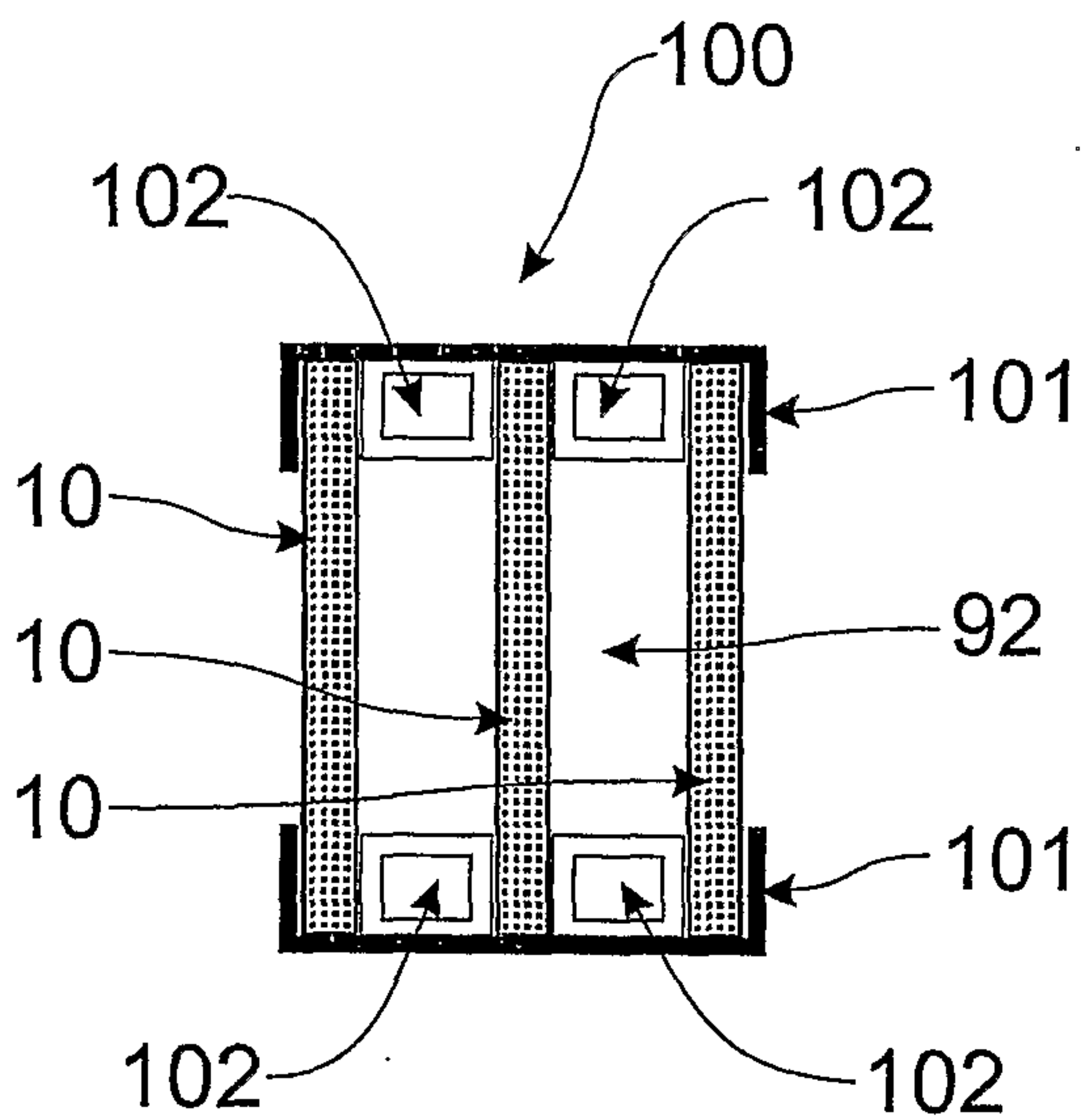

FIG. 10

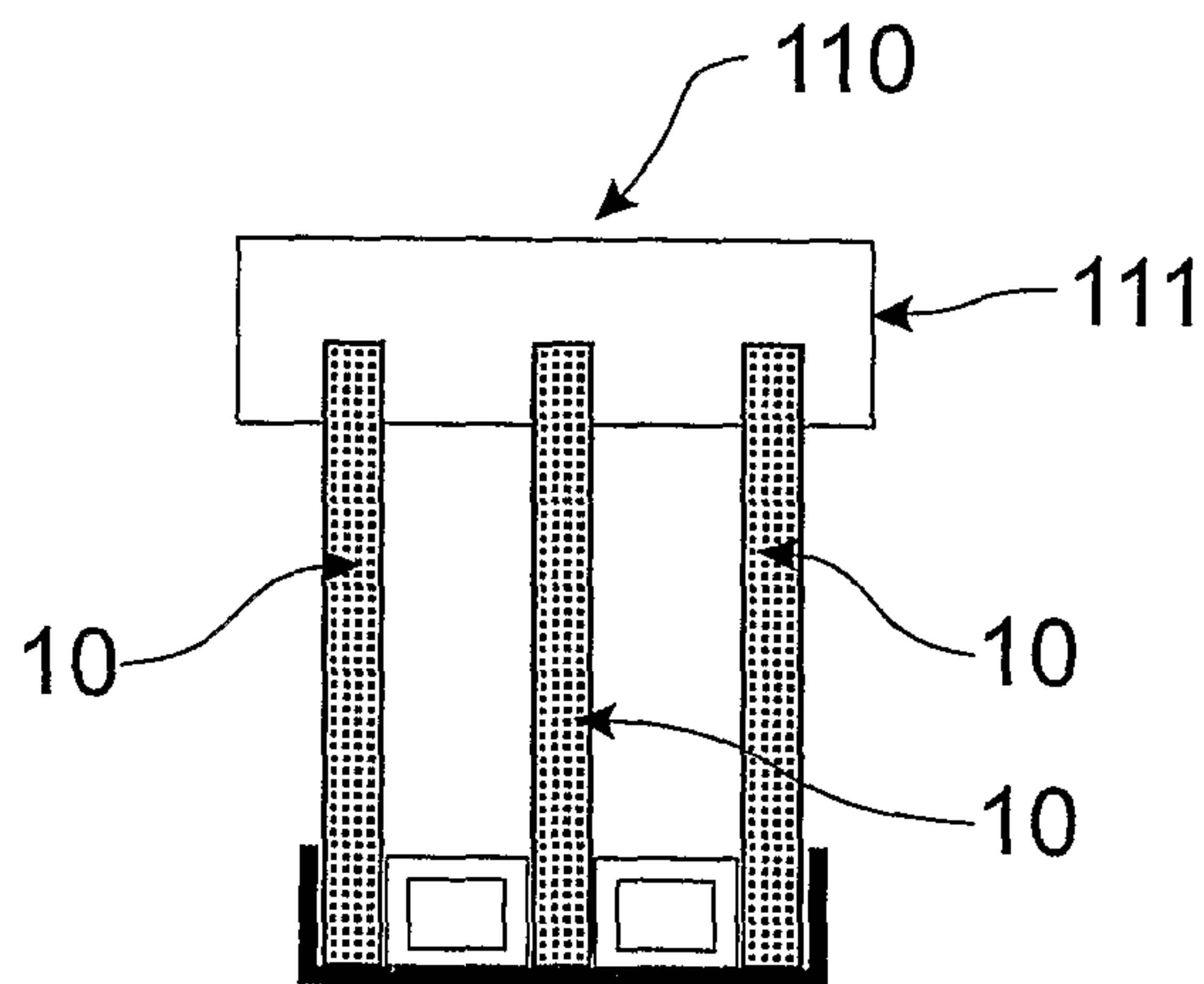

FIG. 11

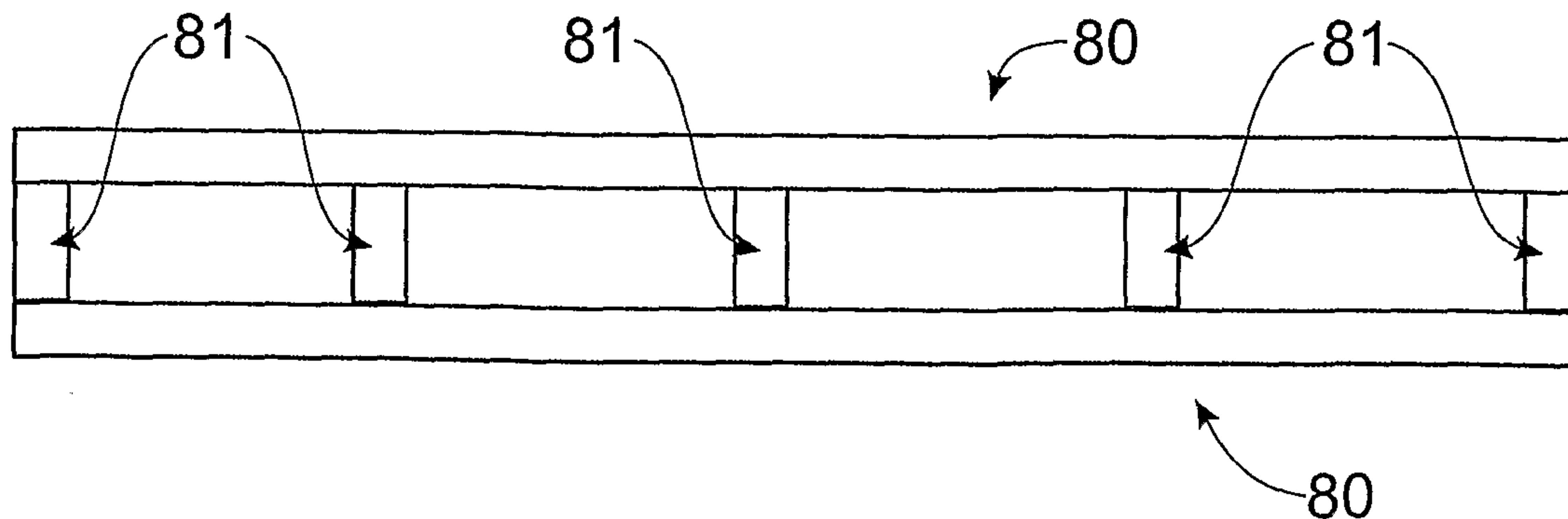

FIG. 12

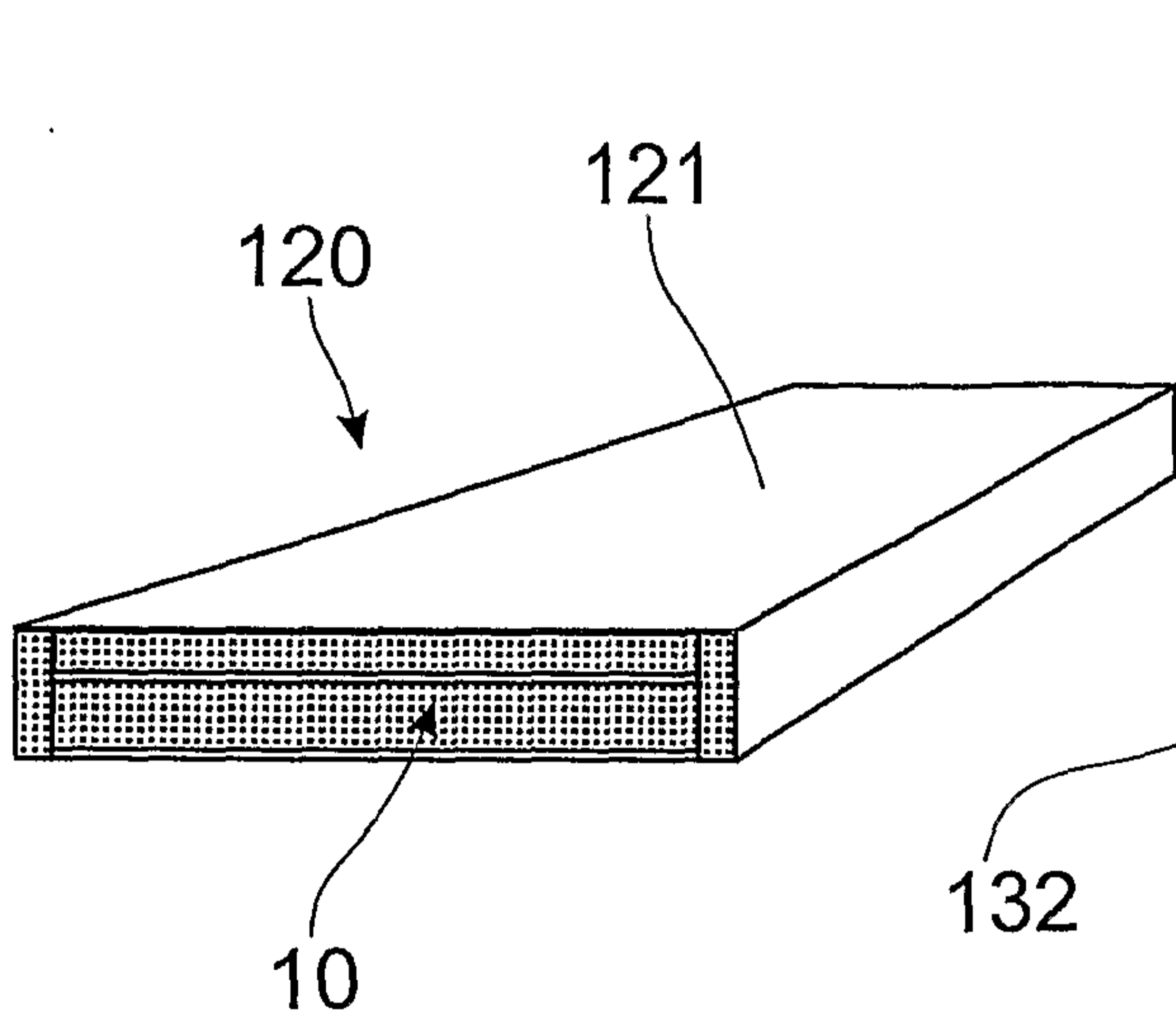

FIG. 13

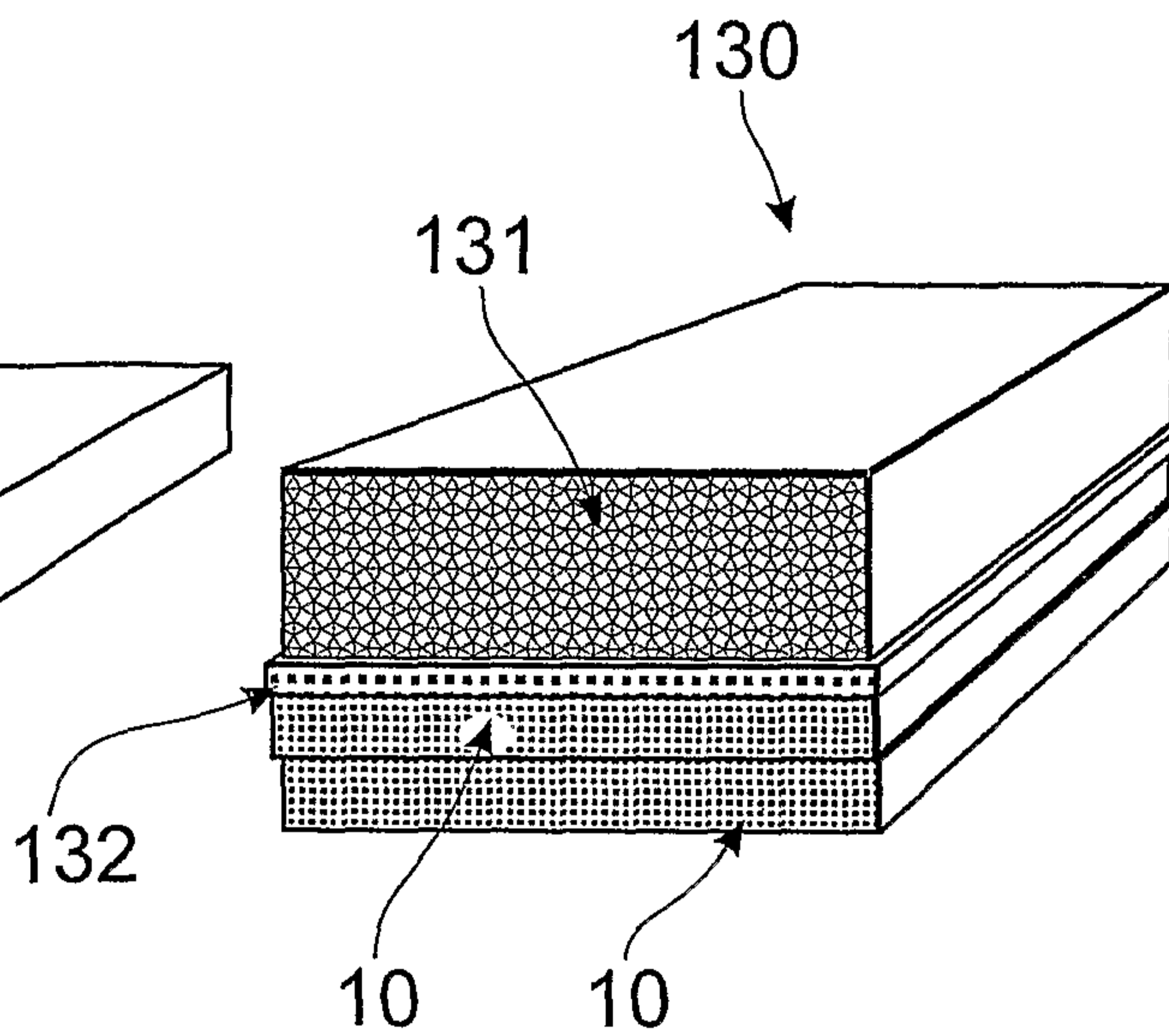

FIG. 14

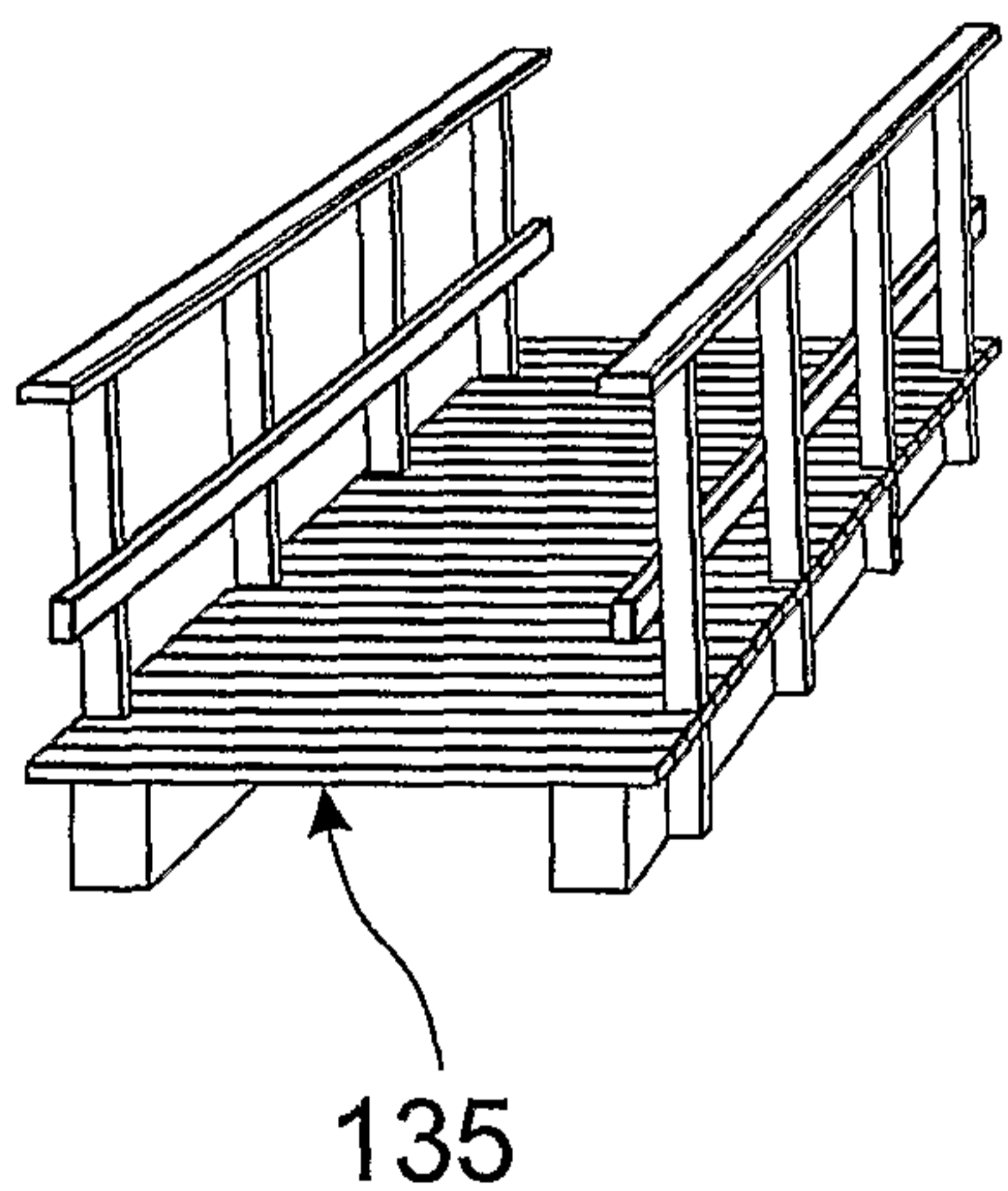

FIG. 15A

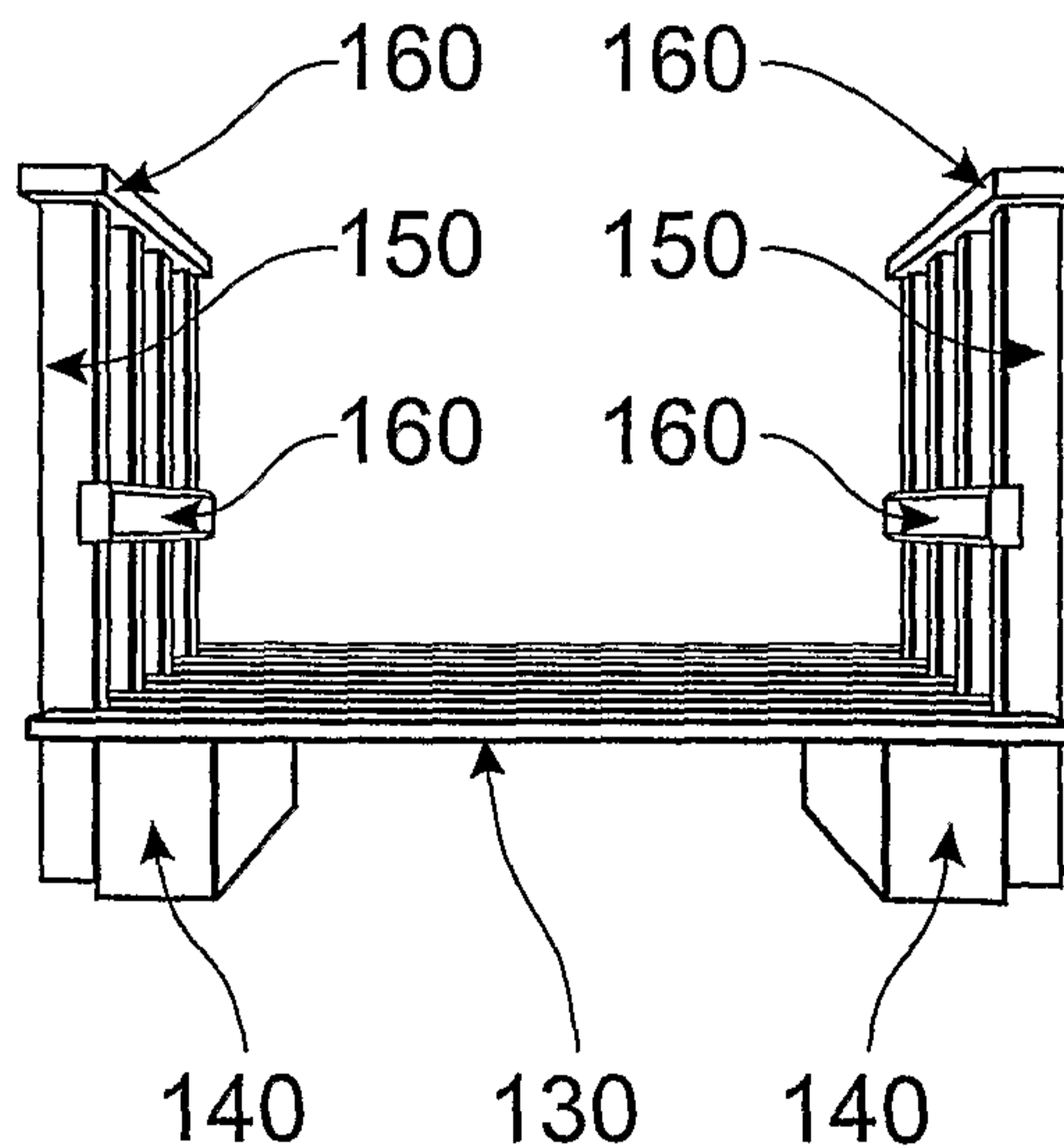

FIG. 15B

4 / 5

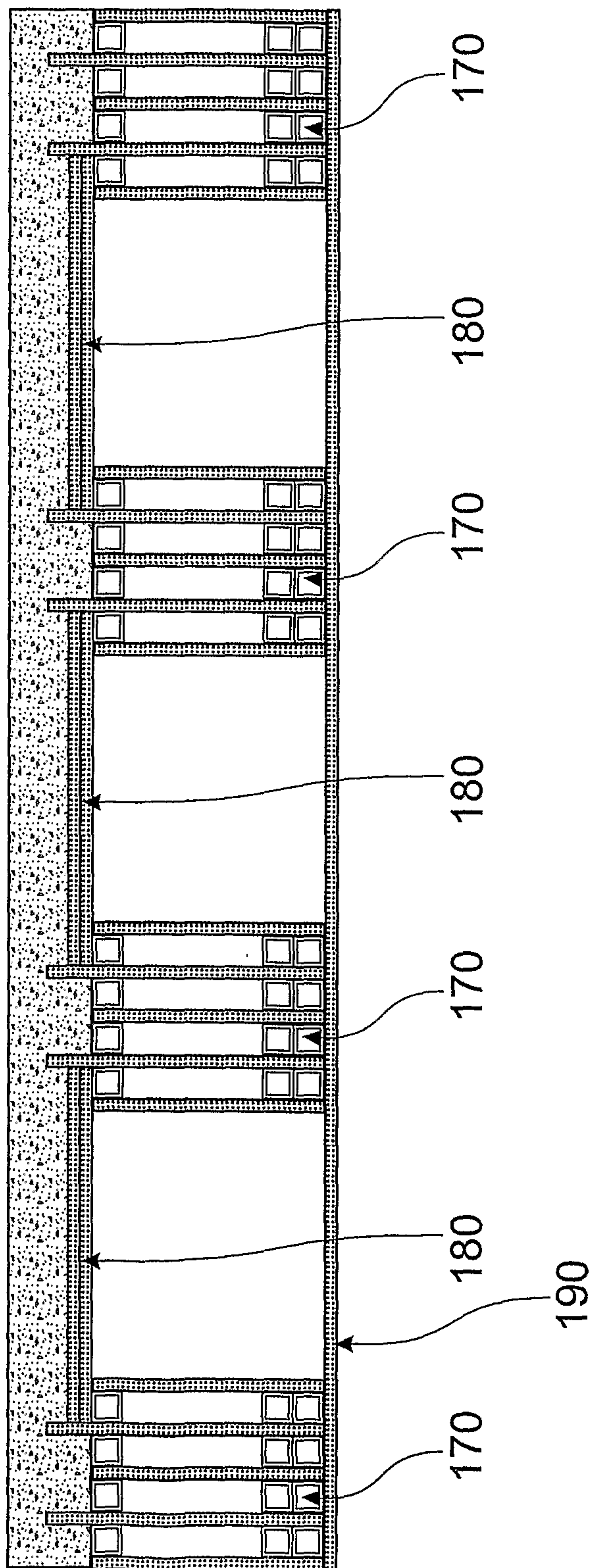

FIG. 16

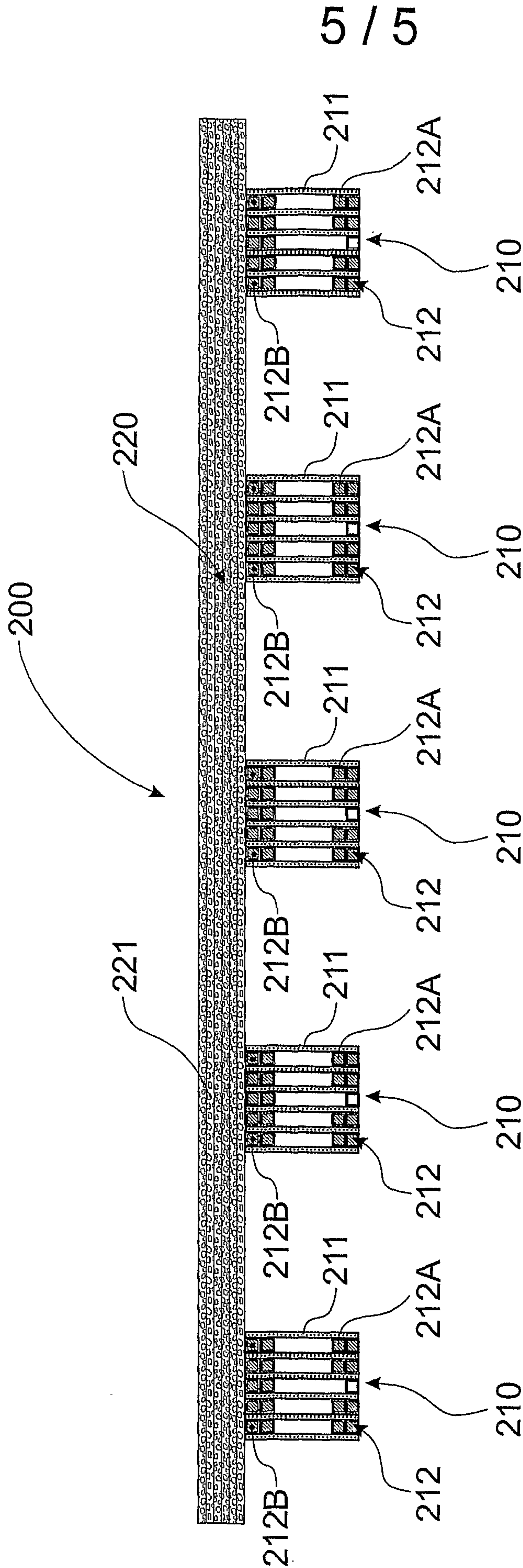

FIG. 17

