

Feb. 10, 1970

C. O. LARSON

3,494,585

ARTICLE SUPPORT CONSTRUCTION

Filed April 15, 1968

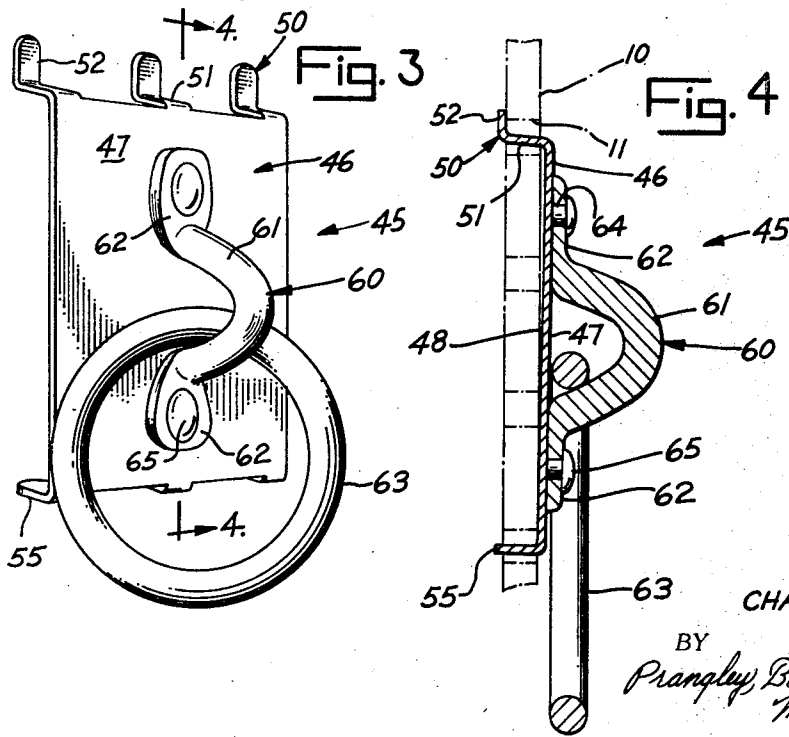
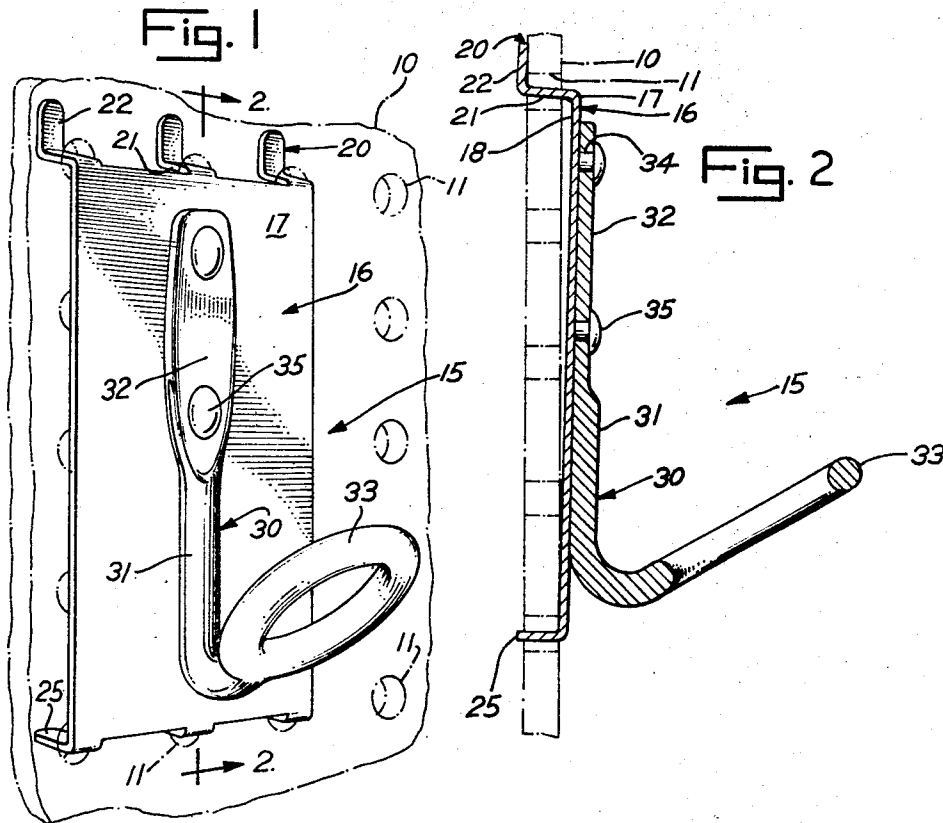

INVENTOR.
CHARLES O. LARSON

BY
*Prangley, Baird, Clayton
Miller & Vogel*
ATTORNEYS

1

3,494,585

ARTICLE SUPPORT CONSTRUCTION

Charles O. Larson, Sterling, Ill., assignor to Chas. O.

Larson, Co., Sterling, Ill., a corporation of Illinois

Filed Apr. 15, 1968, Ser. No. 721,286

Int. Cl. A47f 5/08; A47k 10/12

U.S. Cl. 248—223

6 Claims

ABSTRACT OF THE DISCLOSURE

The article support construction is for use on a apertured panel and comprises a base, a plurality of mounting prongs on the upper edge of the base each including a rearwardly extending first finger and an upwardly extending second finger on the rear end of the first finger and disposed normal thereto, a hanger including an attachment portion having a ring support portion thereon, a ring carried by the ring support portion, the attachment portion being connected to the base, the attachment portion and the ring support portion having a common longitudinal axis normal to the upper edge of the base, the first and second fingers cooperating to mount the hanger on the apertured panel.

This invention is directed to article support constructions for use on an apertured panel and more particularly to an article support construction having a ring thereon.

In summary, the article support construction incorporating the features of the invention is for use on an upstanding apertured panel having a plurality of holes arranged in equidistantly spaced horizontal rows and vertical columns, the article support construction comprising a base having substantially flat front and rear surfaces, a plurality of mounting prongs on one edge of the base, each of the prongs including a first finger extending from the rear surface and disposed substantially normal thereto and having a predetermined length and including a second finger on the outer end of the first finger and extending therefrom in a direction opposite to the base, each of the mounting prongs being spaced from an adjacent mounting prong by a predetermined distance, a hanger including a substantially flat attachment portion and a ring support portion on the attachment portion and a ring carried by the ring support portion, the attachment portion and the ring support portion having a common longitudinal axis, the attachment portion being disposed adjacent to the front surface of the base, and fasteners connecting the attachment portion to the base with the common longitudinal axis generally normal to the one edge of the base, the rear surface of the base bearing in use against the front surface of the associated apertured panel, with the first fingers extending through associated holes in the apertured panel, and the second fingers extending upwardly behind the apertured panel, thereby to mount the hanger on the apertured panel.

Further features of the invention pertain to the particular arrangement of the parts of the article support construction whereby the above outlined and additional operating features thereof are attained.

The invention, both as to this organization and method of operation, together with further objects and advantages thereof, will best be understood by reference to the following specification taken in connection with the accompanying drawing, in which:

FIGURE 1 is a perspective view of one embodiment of an article support construction incorporating the features of the invention;

FIG. 2 is a cross-sectional view of the article support construction of FIG. 1 along the lines 2—2 thereof;

FIG. 3 is a perspective view of another embodiment of the article support construction; and

2

FIG. 4 is a cross-sectional view of the article support construction of FIG. 3 along the lines 4—4 thereof.

Referring now to the drawings, and more particularly to FIGURES 1 and 2 thereof, there is shown an article support construction 15 for use on a apertured panel 10, the apertured panel 10 being shown in phantom and having therein a plurality of holes 11 arranged in equidistantly spaced horizontal rows and vertical columns. The article support construction 15 comprises a base 16 stamped from a unitary metal sheet, the base 16 having a substantially flat front surface 17 and a substantially flat rear surface 18. There are provided three mounting prongs on one edge of the base 16, namely the upper edge thereof as viewed in FIG. 1. Each of the mounting prongs 20 includes a first finger 21 extending rearwardly from the rear surface 18 and disposed substantially normal thereto and having a length approximately equal to the thickness of the apertured panel 10. Each of the mounting prongs 20 further includes a second finger 22 on the outer end of the first finger 21 and extending therefrom in a direction opposite to the base 16, that is, the second finger 22 extends upwardly as viewed in FIG. 1. The mounting prongs 20 are spaced from one another by distances equal to the distance between two of the apertured panel holes 11 in a horizontal row. Three stabilizing prongs 25 are disposed on the lower edge of the base 16 and extend rearwardly from the rear surface 18 and are disposed substantially normal thereto, the stabilizing prongs 25 each being vertically aligned with an associated first finger 21 and spaced therefrom by a distance equal to the distance between two of the apertured panel holes 11 in a vertical column.

The article support construction 15 further comprises a hanger 30, the hanger 30 including a bar having one part thereof flattened to define an attachment portion 32 with the remaining part of the bar defining a ring support portion 31. The hanger 30 further includes a ring 33 integral with the free end of the ring support portion 31, the plane defined by the ring 33 being directed forwardly and upwardly. The attachment portion 32 has therein two axially aligned holes 34, the attachment portion 32 lying adjacent to the front surface 17 of the base 16 and being connected to the base 16 by dropping through the holes 34 hot metal which flows between the abutting surfaces of the attachment portion 32 and the base 16, a round head 35 being formed over each of the holes to give the article support construction 15 an attractive appearance.

In use, the first fingers 21 on the base 16 extend through associated holes 11 in the apertured panel 10, the second fingers 22 extend upwardly behind the apertured panel, and the rear surface 18 of the base 16 bears against the front surface of the apertured panel 10, thereby to mount the hanger 30 on the apertured panel 10 in cantilever fashion. Further, the stabilizing prongs 25 extend through associated holes in the apertured panel 10 to orient and provide additional support for the article support construction 15. The ring 33 then extends upwardly and forwardly, whereby it is adapted to carry an article thereon.

Referring now to FIGS. 3 and 4 of the drawings, there is shown a further article support construction 45 which comprises a base 46 stamped from a unitary metal sheet, the base 46 having a substantially flat front surface 47 and a substantially flat rear surface 48. There are provided three mounting prongs 50 on one edge of the base 46, namely the upper edge thereof as viewed in FIG. 3. Each of the mounting prongs 50 includes a first finger 51 extending rearwardly from the rear surface 48 and disposed substantially normal thereto and having a length approximately equal to the thickness of apertured panel 10. Each of the mounting prongs 50 further includes

a second finger 52 on the outer end of the first finger 51 and extending therefrom in a direction opposite to the base 46, that is, the second finger 52 extends upwardly as viewed in FIG. 1. The mounting prongs 50 are spaced from one another by distances equal to the distance between two of the apertured panel holes 11 in a horizontal row. Three stabilizing prongs 55 are disposed on the lower edge of the base 46 and extend rearwardly from the rear surface 48 and are disposed substantially normal thereto, the stabilizing prongs each being vertically aligned with an associated first finger 51 and spaced therefrom by a distance equal to the distance between two of the apertured panel holes 11 in a vertical column.

The article support construction 45 further comprises a hanger 60, the hanger 60 including a ring support portion 61 which is arched-shaped in longitudinal cross-section, and a pair of attachment flanges 62 respectively integrally joined to the free ends of the ring portion 61. The pair of attachment flanges 62 are disposed in the same plane and in general longitudinal alignment and extend in opposite directions from each other. The attachment flanges 62 are disposed adjacent the front surface 47, with the common longitudinal axis of the ring support portion 61 and the attachment flanges 62 being disposed substantially normal to the upper edge of the base 16. The attachment flanges 62 each have a hole 64 therein, the attachment flanges being connected to the base 16 by dropping hot metal through the holes 64 in the manner described with reference to FIGS. 1 and 2. A ring 63 is loosely supported by the bearing defined between the front surface 47 of the base 46 and the ring support portion 61.

In use, the first fingers 51 on the base 46 extend through associated holes 11 in the apertured panel 10, the second fingers 52 extend upwardly behind the apertured panel, and the rear surface 48 of the base 46 bears against the front surface of the apertured panel 10, thereby to mount the hanger 60 on the apertured panel 10 in cantilever fashion. Further, the stabilizing prongs 55 extend through associated holes in the apertured panel 10 to orient and provide additional support for the article support construction 45. In an operating condition, the ring support portion 61 extends forwardly and the ring 63 is loosely supported thereby and is adapted to carry an article such as a towel thereon.

While there has been described what is at present considered to be the preferred embodiments of the invention, it will be understood that various modifications may be made therein.

What is claimed is:

1. An article support construction for use on an upstanding apertured panel having a plurality of holes arranged in equidistantly spaced horizontal rows and vertical columns, said article support construction comprising a base having substantially flat front and rear surfaces, a plurality of mounting prongs on the edge of said base, each of said prongs including a first finger extending from said rear surface and disposed substantially normal thereto and having a predetermined length and including a second finger on the outer end of said first finger and extending therefrom in a direction opposite to said base, each of said mounting prongs being spaced from an adjacent mounting prong by a predetermined distance, a hanger including a substantially flat attachment portion and a ring support portion on said attachment portion

and a ring carried by said ring support portion, said attachment portion and said ring support portion having a common longitudinal axis, said attachment portion being disposed in contact with the front surface of said base, and fasteners fixedly connecting said attachment portion to said base with said common longitudinal axis generally normal to said one edge of said base, the rear surface of said base bearing in use against the front surface of the associated apertured panel, with said first fingers extending through associated holes in the apertured panel and the second fingers extending upwardly behind the apertured panel, thereby to mount said hanger on the apertured panel.

2. The article support construction set forth in claim 1, and further comprising at least one stabilizing prong on said base and extending from the rear surface thereof and disposed substantially normal thereto and vertically aligned with one of said first fingers, said stabilizing prong extending in use into the associated hole in the apertured panel to orient and provide additional support for the article support construction.

3. The article support construction set forth in claim 1, and further comprising a plurality of stabilizing prongs on the edge of said base opposing said one edge thereof and extending from the rear surface thereof and disposed substantially normal thereto and vertically aligned with the associated first fingers, said stabilizing prongs extending in use into associated holes in the apertured panel to orient and provide additional support for the article support construction.

4. The article support construction set forth in claim 1, wherein a bar has one part thereof flattened to define said attachment portion and the remaining part thereof defines said ring support portion, and said ring is integral with the free end of said ring support portion.

5. The article support construction set forth in claim 4, wherein the plane defined by said ring is directed forwardly and towards said one edge of said base.

6. The article support construction set forth in claim 1, wherein said ring support portion is arch-shaped in longitudinal cross section and is directed forwardly, said attachment portion including a pair of attachment flanges respectively integrally joined to the free ends of said ring support portion, said pair of attachment flanges being disposed in the same plane and in general longitudinal alignment and in opposite directions from each other and adjacent the front surface of said base, said fasteners connecting said attachment flanges to said base, whereby a laterally extending bearing is defined between the front surface of said base and said ring support portion, and said ring is loosely supported by said bearing.

References Cited

UNITED STATES PATENTS

1,506,694	8/1924	Toffey	16—126
2,353,017	7/1944	Denton	248—361
2,842,264	7/1958	Larson	

60 ROY D. FRAZIER, Primary Examiner

J. FRANKLIN FOSS, Assistant Examiner

U.S. Cl. X.R.

65 248—216