

*J. C. Kilgore,*

*Sectional Boiler.*

*No. 107,181.*

*Patented Sept. 6. 1870.*

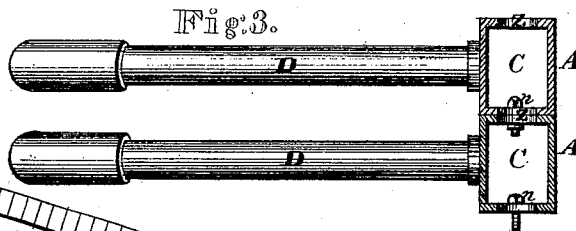
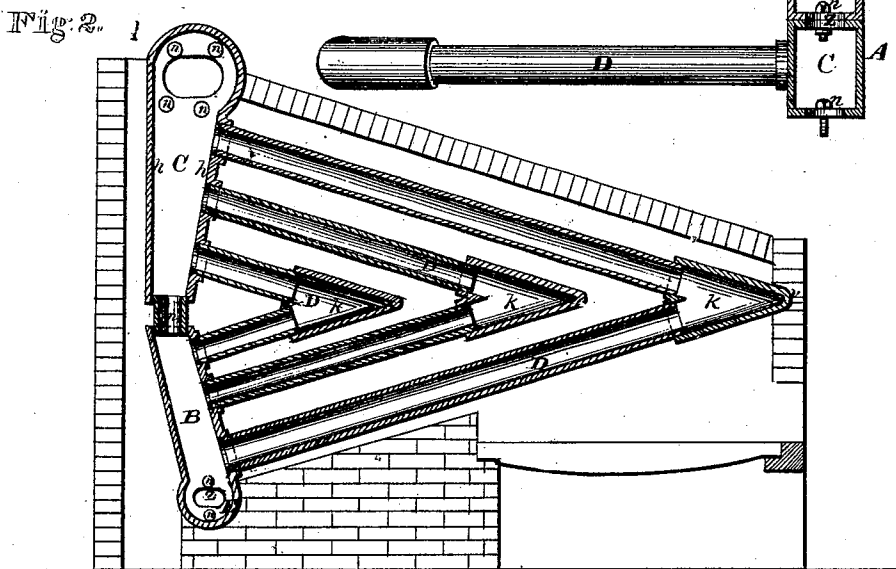
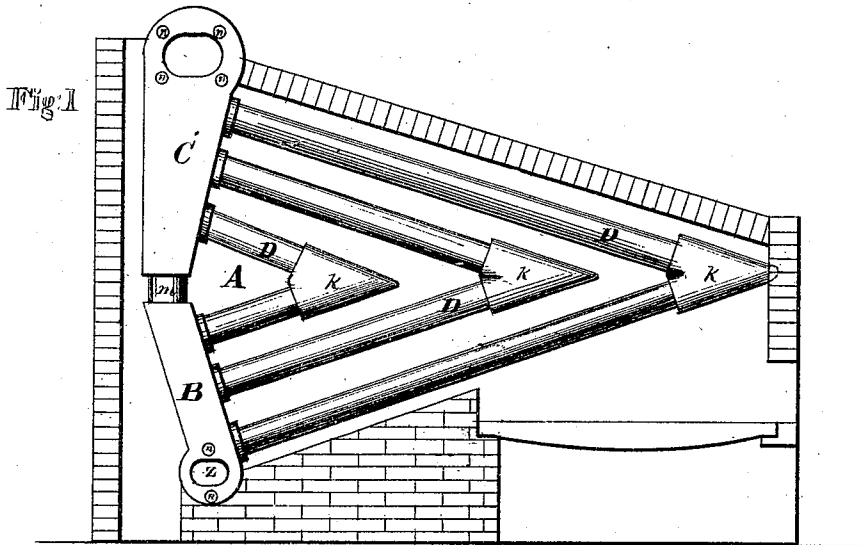

*Witnesses.*

*A. A. Kane*  
*Chas. Kenyon*

*Inventor.*

*J. C. Kilgore,*  
*Chipman Hosmer & Co.*  
*Attorneys.*

# UNITED STATES PATENT OFFICE.

JOHN C. KILGORE, OF PHILADELPHIA, PENNSYLVANIA.

## IMPROVEMENT IN STEAM-GENERATORS.

Specification forming part of Letters Patent No. **107,181**, dated September 6, 1870.

*To all whom it may concern:*

Be it known that I, JOHN C. KILGORE, of Philadelphia, in the county of Philadelphia and State of Pennsylvania, have invented a new and valuable Improvement in Steam-Boilers; and I do hereby declare that the following is a full, clear, and exact description of the construction and operation of the same, reference being had to the annexed drawing, making a part of this specification, and to the letters and figures of reference marked thereon.

Figure 1 of the drawing is a side view of my invention. Fig. 2 is a vertical longitudinal section of the same. Fig. 3 is a top view.

My invention has relation to steam-boilers; and consists in the sectional construction and novel arrangement of the angular pipes and the steam and mud drums; also, in the plan adopted whereby the sections are secured together from the inside.

The object of the invention is to avoid leakage and to prevent the mud or sediment from settling upon the generating-surfaces.

It will be observed that the principle upon which my boiler has been constructed avoids level or horizontal surfaces.

The letter A of the drawing designates one of the sectional boilers. It consists of the mud-drum B and the steam-drum C, and the angular pipes D, connecting the two drums.

The upper portion of the chamber B is bounded by parallel walls, two of which are perpendicular and two oblique to the vertical plane. The latter are designated by the letter *e*. These plane walls are connected at the lower end of the drum with a cylindrical receptacle, E.

Hand-holes *z z* are formed in the ends of the cylinder E, and serve as a means of communication between the sectional drums, and at the same time afford access to the hand in securing the bolts which fasten the sections together.

It will be observed that the vertical walls of the drums are placed in contact with each other, the bolts *n n* being passed through the walls immediately about the edges of the hand-holes, and secured from the inside.

Short bolts or rivets are employed, of sufficient length to span the thickness of the two walls which are in contact.

The oblique walls of the chamber are inclined

upward in a direction perpendicular to the direction of the pipes D.

The mud-drum is connected to the steam-drum above by the short pipe *m*. The upper or steam drum, C, is semi-cylindrical at the top, and thence tapers downward, the converging walls *h h* being oblique to the perpendicular. The other two walls of the drum are vertical and parallel, and in joining the sections are placed in contact. The slope of the inner oblique wall, *h*, is perpendicular to the direction of the upper branch of the angular pipes D.

Hand-holes are formed at the upper part of the steam-drum, and serve similar purposes with those mentioned above in connection with the mud-drum.

The steam-drum is connected to the mud-drum by the short pipes *m*, and by a series of angular >-shaped pipes, D, so arranged that throughout the whole of their extent there shall be no level or horizontal surface for the mud or sediment to collect upon. The angular pipes D consist of two branches, respectively perpendicular in direction to the inner oblique walls of the mud and steam drums. The two branches may be connected by a curve or bend, or by means of an angular thimble, *k*, as shown in the drawing. The number of angular pipes to each section is not limited. The longest pipe starts from the lowest portion of the mud-drum and extends to the upper part of the steam-drum. Within the span of this outer pipe a series of smaller angular pipes may be placed, decreasing gradually in length until the whole of the space between the outer pipe and the drums is filled.

In building my boiler into brick-work, holes *v v* should be made to support the pipes D at the angles. In the manner above described a boiler of any size may be constructed. The sections may be kept on hand, and a small or large boiler formed by securing the proper number of them together.

The edges of the openings in the walls, by which the drums communicate, are secured together in the strongest possible manner, by means of short bolts or rivets, and, from the manner of their application, they are not subject to external violence.

What I claim as my invention, and desire to secure by Letters Patent, is—

1. The boiler herein described, composed of

sections A, each section consisting of a downwardly-tapering steam-drum, C, mud-drum B, connecting-tube *m*, and >-shaped or angular pipes D, substantially as specified.

2. In combination with a steam-drum, C, and mud-drum B, the >-shaped angular or bent pipes D, having their branches inclined to the horizontal, as specified.

3. The sectional boiler A, consisting of pipes and steam and mud drums, provided with in-

terior hand-holes *z*, and secured together by short bolts or rivets *n* from the inside, substantially as specified.

In testimony that I claim the above I have hereunto subscribed my name in the presence of two witnesses.

J. C. KILGORE.

Witnesses:

ANDRO J. BOSWELL,  
ERICH REINHARD.