

(19) World Intellectual Property
Organization
International Bureau



(43) International Publication Date
26 February 2004 (26.02.2004)

PCT

(10) International Publication Number
WO 2004/017536 A2

- (51) International Patent Classification⁷: **H04B 7/00**
- (21) International Application Number:
PCT/US2003/024104
- (22) International Filing Date: 31 July 2003 (31.07.2003)
- (25) Filing Language: English
- (26) Publication Language: English
- (30) Priority Data:
10/223,251 19 August 2002 (19.08.2002) US
- (71) Applicant: **INTEL CORPORATION** [US/US]; 2200
Mission College Boulevard, Santa Clara, CA 95052 (US).
- (72) Inventor: **TSIEN, Chih**; 7131 Park Village Road, San
Diego, CA 92129 (US).
- (74) Agent: **MALLIE, Michael, J.**; Blakely, Sokoloff, Taylor
& Zafman, 12400 Wilshire Boulevard, 7th Floor, Los An-
geles, CA 90025 (US).
- (81) Designated States (*national*): AE, AG, AL, AM, AT, AU,
AZ, BA, BB, BG, BR, BY, BZ, CA, CH, CN, CO, CR, CU,
CZ, DE, DK, DM, DZ, EC, EE, ES, FI, GB, GD, GE, GH,
GM, HR, HU, ID, IL, IN, IS, JP, KE, KG, KP, KR, KZ, LC,
LK, LR, LS, LT, LU, LV, MA, MD, MG, MK, MN, MW,
MX, MZ, NI, NO, NZ, OM, PG, PH, PL, PT, RO, RU, SC,
SD, SE, SG, SK, SL, SY, TJ, TM, TN, TR, TT, TZ, UA,
UG, UZ, VC, VN, YU, ZA, ZM, ZW.
- (84) Designated States (*regional*): ARIPO patent (GH, GM,
KE, LS, MW, MZ, SD, SL, SZ, TZ, UG, ZM, ZW),
Eurasian patent (AM, AZ, BY, KG, KZ, MD, RU, TJ, TM),
European patent (AT, BE, BG, CH, CY, CZ, DE, DK, EE,
ES, FI, FR, GB, GR, HU, IE, IT, LU, MC, NL, PT, RO,
SE, SI, SK, TR), OAPI patent (BF, BJ, CF, CG, CI, CM,
GA, GN, GQ, GW, ML, MR, NE, SN, TD, TG).
- Published:**
— *without international search report and to be republished
upon receipt of that report*
- For two-letter codes and other abbreviations, refer to the "Guid-
ance Notes on Codes and Abbreviations" appearing at the begin-
ning of each regular issue of the PCT Gazette.*



WO 2004/017536 A2

(54) Title: DYNAMIC FREQUENCY SELECTION AND RADAR DETECTION WITH A WIRELESS LAN

(57) Abstract: A receiver in a wireless communication system detects a possibly interfering radar signal, and uses dynamic frequency selection to switch to a non-interfering channel. The power level and the channel of the radar signal may be detected. When a radar signal that exceeds a predetermined power level is detected, the receiver may be tuned until the channel of the radar signal matches the communication receiver channel. The communication receiver may then be tuned to a higher quality channel to mitigate or avoid interference between communication signals and the radar signal.

DYNAMIC FREQUENCY SELECTION AND RADAR DETECTION WITH A WIRELESS LAN

BACKGROUND

5 [0001] Wireless local area network (LAN) equipment operating in a 5 GHz band
may have dynamic frequency selection (DFS) capability based on European Radio
Communications Committee decision. Wireless LAN (WLAN) and radar equipment
operating at the 5 GHz band may interfere with each other when operating at the same
frequencies and within the operating range. In order to protect radar operation, the WLAN
10 system or device should detect radar signals first to avoid collision with radar channel
during an initiate phase. In addition, the WLAN should periodically re-check the
operating channel frequency since the radar source may be moving such as airborne radar.

[0002] Implementation of dynamic frequency selection specifies that radar signals
15 having a level of at least -52 dBm should be detected. Next, a response to a detected radar
signal should result in a switch to an available channel. A best or better available channel
should be selected with uniform spreading over the operating band.

[0003] Detecting a radar signal is an issue in implementing dynamic frequency
20 selection since the radar signal characteristics may be different from wireless LAN signal
characteristics. Typical radar signal ranges may be:

Signal Bandwidth:	0.7 MHz to 150 MHz
Pulse repetition rate:	20-100,000 pulses per second
Pulse duration:	0.05 – 100 us

[0004] Differences between a communication receiver and a radar receiver include bandwidth and time response. Typical 5 GHz wireless LAN systems such as 802.11a and HiperLAN-II may be designed for a 17 MHz signal bandwidth, and may exhibit severe distortion from interference by a narrow radar pulse. As a result, it is difficult to use the LAN receiver or system to correctly estimate radar signal power for radar signals that may have differing pulse signal durations.

DESCRIPTION OF THE DRAWING FIGURES

[0005] The numerous advantages of the present invention may be better understood by those skilled in the art by reference to the accompanying figures in which:

[0006] FIG. 1 is a block diagram of a communication system in accordance with one embodiment of the present invention.

[0007] FIG. 2 is a block diagram of a communication system with a radar detection receiver in accordance with one embodiment of the present invention.

[0008] FIG. 3 is a flow chart of a method for radar detection and dynamic frequency selection in accordance with one embodiment of the present invention.

20

DETAILED DESCRIPTION

[0009] Referring now to FIG. 1, a block diagram of a communications system in accordance with an embodiment of the present invention will be discussed. In one embodiment, communications system 100 may include a base station 110 that may communicate with one or more devices 112-114, over one or more communication links 116-118. In one embodiment, at least one or more of communications links 116-118 may

be a wireless link, such as a radio-frequency communications link in a cellular telephone network, although the scope of the present invention is not limited in this respect. Devices 112-114 may be wireless phones, personal digital assistants, computers, pagers, portable music players, or any other device capable of communicating with base station 110 via at least one or more communication links 116-118, although the scope of the present invention is not limited in this respect.

[0010] In one embodiment, at least one or more of devices 112-114 may be transportable by a user, such as a hand held device, and may be operated by a user while being hand held or otherwise on the person of the user, such as in a pocket, attached to a belt or holster, and so on. Base station 110 may allow devices 112-114 to communicate with other devices 112-114, and may allow devices 112-114 to communicate via network 120. In one embodiment, network 120 may be a wide area network or world wide network such as the Internet, although the scope of the present invention is not limited in this respect.

[0011] In one embodiment, at least one or more of devices 112-114 may be battery operated where the battery serves as a power source during operation, and may alternatively be powered from an external power source such as an ac or dc power source, directly, to charge the battery, or to provide supplemental power to the device, although the scope of the present invention is not limited in this respect. In one embodiment of the invention, communications system 100 may comprise a wireless local area network (LAN), a wireless wide area network (WAN) or a cellular network compliant with at least one or more cellular standards, including but not limited to 3GPP, WCDMA, CDMA 2000, GSM-GPRS, GSM-EGPRS, IEEE Standards 802.11a, 802.11b, and so on, although the scope of the present invention is not limited in this respect. Other wireless standards may be utilized without departing from the scope of the invention and without providing substantial change thereto.

[0012] In one embodiment of the invention, a radar source 122 may emit radar signals 124 that could possibly interfere with the operation of base station 110 and devices 112-114. For example, base station 110 and devices 112-114 may operate at a 5 GHz band, so that radar signals 124 may interfere with signals on wireless communication links 116-118, and vice versa. In such an embodiment, base station 110 and devices 112-114 may utilize radar detection and dynamic frequency selection in accordance with one embodiment of the present invention to mitigate, reduce, or eliminate such interference. An example of a wireless LAN system that may incorporate an embodiment of the present invention may include systems compliant with an IEEE 802.11a standard or a HiperLAN-II standard, although the scope of the invention is not limited in this respect. Base station 110 and devices 112-114 may include a receiver such as shown in and described with respect to FIG. 2 that implements an embodiment of radar detection and dynamic frequency selection.

15 [0013] Referring now to FIG. 2, a block diagram of a communication system in accordance with an embodiment of the present invention will be discussed. In the diagram of receiver 200, receiver input stage unit 210 may be, for example, a 5 GHz receiver input stage 210 with a wide bandwidth around 675 MHz. Receiver input stage may also be referred to as a front-end and may include one or more filters, although the scope of the invention is not limited in this respect. Receiver 200 may be utilized by base station 110 and devices 112-114 of communications system 100 of FIG. 1. Communication receiver 212 may be a wireless LAN receiver and may have, for example, an 8.5 MHz bandwidth for direct conversion architecture, or alternatively a 17 MHz for double conversion architecture, although the scope of the invention is not limited in this respect. Signals may pass through communication receiver 212 through a down converter 226, filter 228, automatic gain control (AGC) amp 230, filter 232, AGC amp 234, analog-to-digital (A/D) converter 236, and RSSI/SNR unit 238.

[0014] Radar receiver 214 may be arranged to detect a radar signal. A radar signal may pass input stage unit 210 and may then pass to peak detector 216. The output of peak

detector 216 may be the radar pulse envelope, or video signal. The radar pulse may then pass to video amplifier 218, which may be programmable to match a radar receiver chain gain requirement. A pulse delay unit may be used to compensate the delay time of communication receiver 212 to the delay time of the radar pulse, although the scope of the invention is not limited in this respect. In one embodiment, pulse delay unit 220 may be programmable to match the delay of communication receiver 212. The radar pulse may then feed to comparator 222, which may compare the radar pulse signal with a reference signal from reference signal unit 224. In one embodiment, the level of reference signal provided by reference signal unit 224 may be programmable to adjust the threshold of comparator 222 so that the output of comparator 222 may only occur when the radar input signal level at antenna 226 exceeds a level of -52 dBm. Thus, a high output from comparator 222 may be the radar power indication, indicating that the radar signal power level may be equal to or greater than -52 dBm, although the scope of the invention is not limited in this respect. The repetition rate of the radar signal may be counted to characterize the radar signal as well.

[0015] In one embodiment, receiver input stage unit 210 may be broadband in which case radar receiver 214 may only detect the existence of a radar existing and the radar signal power level, but no information may be readily discernable about the radar channel. The radar signal may pass through communication receiver 212 with distortion. As a result, it may be impractical to use communication receiver 212 for power level detection due to the narrow bandwidth of communication receiver 212, and since there may be no fixed relationship between a pulse duration of the radar signal and an output level from automatic gain control (AGC) amplifier 234. However, the pulse shape of the radar signal before analog-to-digital (A/D) converter 236 may still maintain a correct time relationship that may be used to determine a radar channel of the radar signal, although the scope of the invention is not limited in this respect.

[0016] Video detector 240, pulse shaping unit 242, and AND gate 244 may perform a radar channel determination operation. The radar pulse passes from AGC amp

234 to video detector 240 and may feed to pulse shaping unit 242. The output from pulse shaping unit 242 may be a copy of the radar pulse, which is then passed to AND gate 244. If the signals at points A and B are both high, and then the output from AND gate 244 at point C is high, an indication may be provided that the radar channel and communication receiver channel are the same channel or at least interfering. While adjusting the communication receiver local oscillator (LO) frequency by scanning until both outputs from comparator 222 and AND gate 244 are high, a radar signal level greater than -52 dBm may be detected, and the channel of communication receiver 212 is the radar channel. Therefore, the radar channel may be determined tuning the channel of communication receiver 212, although the scope of the invention is not limited in this respect. Selection of the best or a better channel may be based on a receiver signal strength indication (RSSI) or signal-to-noise ratio (SNR) measurement with RSSI/SNR unit 238, although the scope of the invention is not limited in this respect.

15 [0017] An indication that the radar signal strength is greater than or equal to -52 dBm may be indicated by the output of comparator 222. An indication of the radar channel may be indicated when the output of AND gate 244 is high, in which case the radar channel may be the same as the channel of communication receiver 212. An indication of channel signal quality may be indicated by RSSI/SNR unit 238 so a higher quality alternative channel may be selected. In one embodiment of the invention, the architecture or receiver 200 may provide dynamic frequency selection for a 5 GHz wireless LAN without requiring communication receiver 212 to change bandwidth, and without requiring changing a sampling rate of A/D converter 236.

25 [0018] Referring now to FIG. 3, a flow chart of a method for radar detection and dynamic frequency selection in accordance with an embodiment of the present invention will be discussed. The method 300 may begin where a radar signal may be received by receiver 200 at block 310. A comparison between the received radar signal and a reference signal may be made at block 312. A determination may be made at block 314
30 whether the power of the radar signal is equal to or greater than a predetermined threshold

level, for example -52 dBm. In the event the power of the radar signal is determined to be equal to greater than a predetermined level, communication receiver 212 may sweep its channels at block 316 until the channel of communication receiver 316 matches the channel of the radar signal, at which point the radar signal channel may be determined at
5 block 318. A quality of at least one or more channels may be determined at block 320. Communication receiver 322 may then be tuned at block 322 to a higher quality channel.

[0019] Although the invention has been described with a certain degree of particularity, it should be recognized that elements thereof may be altered by persons
10 skilled in the art without departing from the spirit and scope of the invention. It is believed that the dynamic frequency selection and radar detection with a wireless LAN of the present invention and many of its attendant advantages will be understood by the forgoing description, and it will be apparent that various changes may be made in the form, construction and arrangement of the components thereof without departing from the
15 scope and spirit of the invention or without sacrificing all of its material advantages, the form herein before described being merely an explanatory embodiment thereof, and further without providing substantial change thereto. It is the intention of the claims to encompass and include such changes.

CLAIMS

What is claimed is:

5 1. An apparatus, comprising:

 a communication receiver, said communication receiver includes a down-converter
and a receiver signal strength indicator unit; and

 a radar receiver, said radar receiver includes a peak detector and a comparator, the
comparator to compare a radar signal passed from said receiver front end through said
10 peak detector to said comparator with a reference signal to detect a radar signal having a
predetermined power level, and said receiver signal strength indicator unit indicates a
quality of a channel of said communication receiver, said communication receiver to select
a higher quality channel when the radar signal having a predetermined power level is
detected.

15

 2. An apparatus as claimed in claim 1, said radar receiver includes a pulse delay
unit to provide a delayed version of the radar signal from the peak detector to the
comparator.

20 3. An apparatus as claimed in claim 1, said radar receiver includes a pulse delay
unit to provide a delayed version of the radar signal from the peak detector to the
comparator, the pulse delay unit to provide a delay to the radar signal to match a delay of
said communication receiver.

4. An apparatus as claimed in claim 1, said radar receiver includes a pulse delay unit to provide a delayed version of the radar signal from the peak detector to the comparator, the pulse delay unit being programmable to provide a delay to the radar signal to match a delay of said communication receiver.

5

5. An apparatus as claimed in claim 1, said communication receiver having a bandwidth of approximately 5 GHz.

6. An apparatus as claimed in claim 1, further including a wideband receiver input stage to couple to said communication receiver and said radar receiver.

10

7. An apparatus as claimed in claim 1, further including a wideband receiver input stage to couple to said communication receiver and said radar receiver, said wideband receiver input stage having a bandwidth of approximately 675 MHz.

15

8. An apparatus as claimed in claim 1, said communication receiver having an 8.5 MHz bandwidth for direct conversion.

9. An apparatus as claimed in claim 1, said communication receiver having a 17 MHz bandwidth for double conversion.

20

10. An apparatus as claimed in claim 1, the predetermined power level of the radar signal being about -52 dBm.

11. An apparatus as claimed in claim 1, said communication receiver and said radar receiver being disposed in a single integrated circuit.

12. An apparatus as claimed in claim 1, said communication receiver and said
5 radar receiver being disposed in separate integrated circuits.

13. An apparatus as claimed in claim 1, said radar receiver further including a video detector, a pulse shaper, and an AND gate, the AND gate to receive a radar signal passed through said communication receiver through the video detector and the pulse
10 shaper, the AND gate to indicate that a channel of the radar signal channel is the same as a channel of said communication receiver selected by the down converter

14. An apparatus, comprising:

a wireless local area network device, said wireless local area network device to
15 operate at a frequency of about 2 GHz to about 5 GHz; and

a dynamic frequency selection receiver disposed in said wireless local area device, said dynamic frequency selection receiver comprising:

a receiver input stage;

a communication receiver, said communication receiver includes a down-converter
20 and an receiver signal strength indicator unit; and

a radar receiver coupled to said receiver input stage, said radar receiver includes a peak detector and a comparator, the comparator to compare a radar signal passed from a receiver input stage through said peak detector to said comparator with a reference signal to detect a radar signal having a predetermined power level, said radar receiver further
25 including a video detector, a pulse shaper, and said receiver signal strength indicator unit indicates a quality of a channel of said communication receiver, said communication

receiver to select a higher quality channel when the radar signal having a predetermined power level is detected.

15. An apparatus as claimed in claim 14, said radar receiver includes a pulse delay
5 unit to provide a delayed version of the radar signal from the peak detector to the comparator.

16. An apparatus as claimed in claim 14, said radar receiver includes a pulse delay
10 unit to provide a delayed version of the radar signal from the peak detector to the comparator, the pulse delay unit to provide a delay to the radar signal to match a delay of said communication receiver.

17. An apparatus as claimed in claim 14, said radar receiver includes a pulse delay
15 unit to provide a delayed version of the radar signal from the peak detector to the comparator, the pulse delay unit being programmable to provide a delay to the radar signal to match a delay of said communication receiver.

18. An apparatus as claimed in claim 14, said radar receiver further comprising an
20 AND gate, the AND gate to receive a radar signal passed through said communication receiver through the video detector and the pulse shaper, the AND gate to indicate that a channel of the radar signal channel is the same as a channel of said communication receiver selected by the down converter,

19. A method, comprising:

detecting the presence of a radar signal by comparing a level of the radar signal to a reference level to determine when the radar signal has a power level greater than a predetermined power level;

determining the channel on the radar signal by sweeping the channel of a communication receiver until the channel of the communication receiver matches the
5 channel of the radar signal; and

switching the channel of the communication receiver to another channel.

20. A method as claimed in claim 19, said switching including selecting a channel
10 alternative to the determined channel of the radar signal by selecting a channel having a higher signal-to-noise ratio.

21. A method as claimed in claim 19, said detecting the presence of a radar signal when the radar signal has a power level greater than about -52 dBm.

15

22. A method as claimed in claim 19, said detecting including detecting a peak of the radar signal prior to said comparing.

23. A method as claimed in claim 19, said detecting including delaying the radar
20 signal by a predetermined delay prior to the comparing.

24. A method as claimed in claim 19, said detecting including delaying the radar signal by a predetermined delay prior to said comparing, the predetermined delay to match a delay of the communication receiver.

25

25. An apparatus, comprising:

a wireless local area network receiver to receive a communications signal;

a radar receiver to detect a radar signal; and

a channel selector to switch said wireless local area network receiver to a higher
5 quality channel when said radar receiver detects a radar signal.

26. An apparatus as claimed in claim 25, further comprising a wideband receiver
front end to provide a wideband signal to said wireless local area network receiver and to
said radar receiver.

10

27. An apparatus as claimed in claim 25, further comprising a radar power
detector to detect a power level of a radar signal when the power level is at least a
predetermined value.

15 28. An apparatus as claimed in claim 25, further comprising a radar channel
detector for detecting a channel of the radar signal.

20 29. An apparatus as claimed in claim 25, further comprising a radar power
detector to detect a power level of a radar signal when the power level is at least a
predetermined value, and a radar channel detector for detecting a channel of the radar
signal.

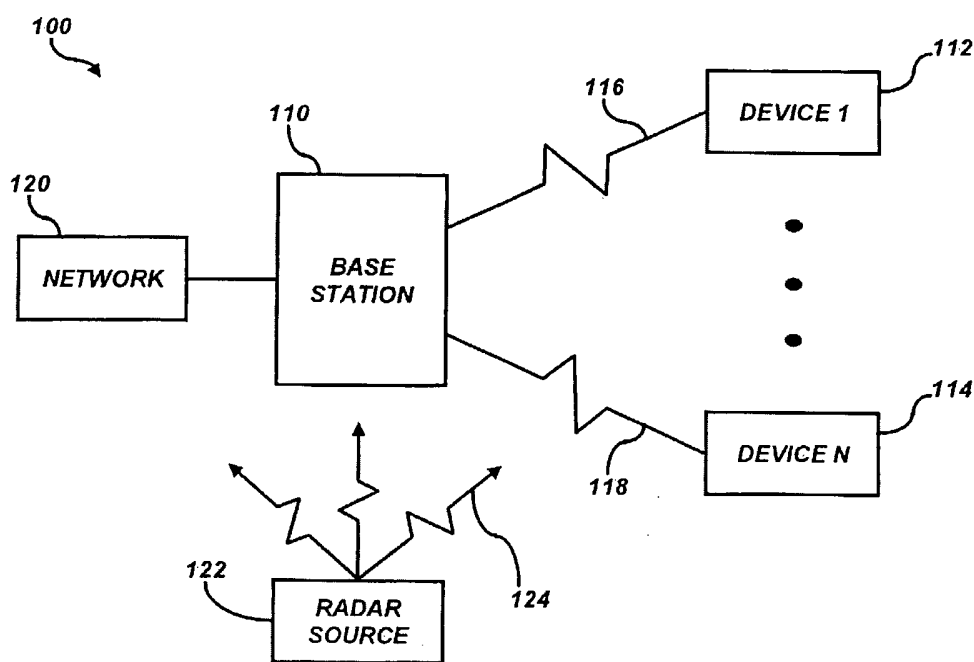

FIG. 1

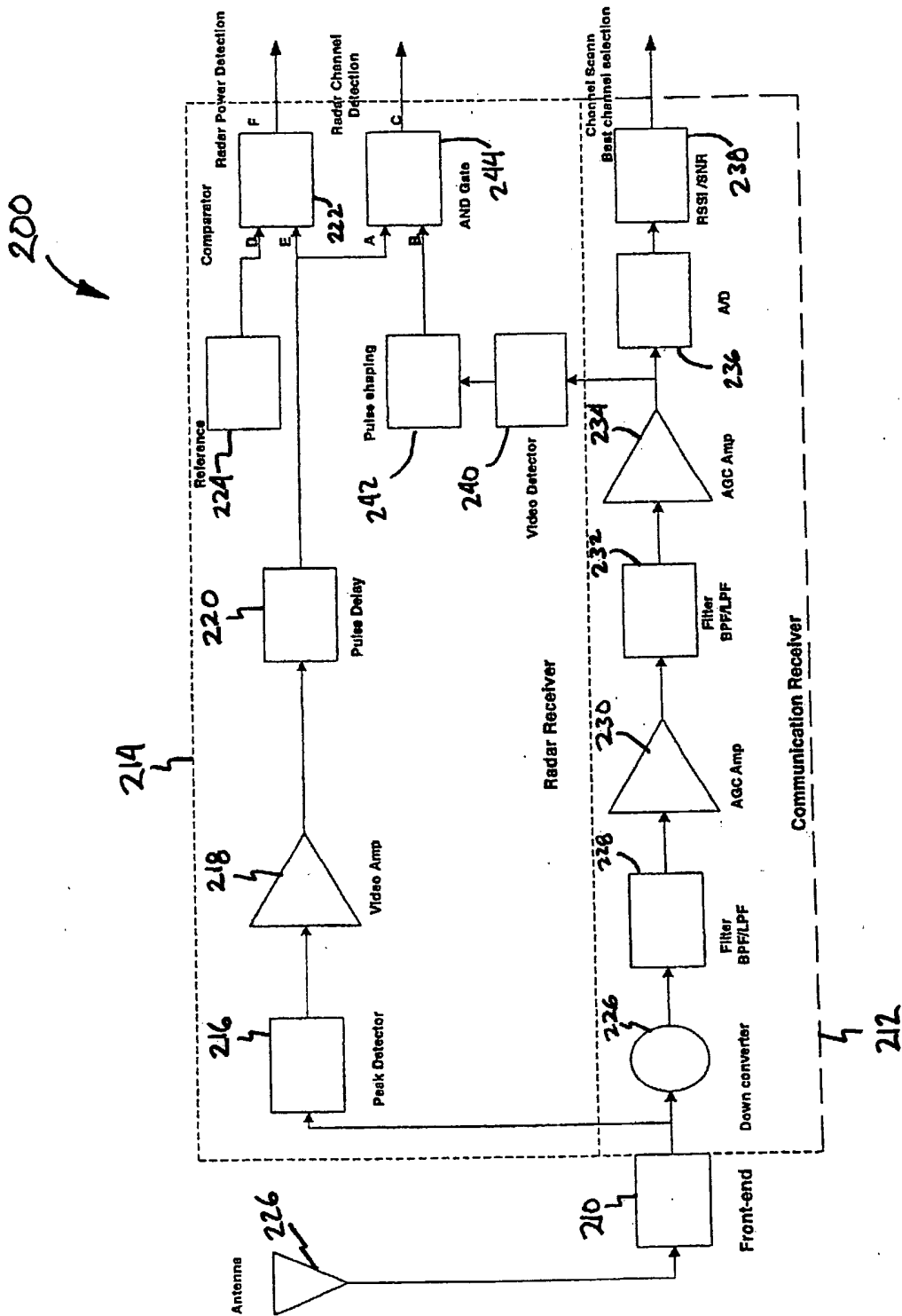

FIG. 2

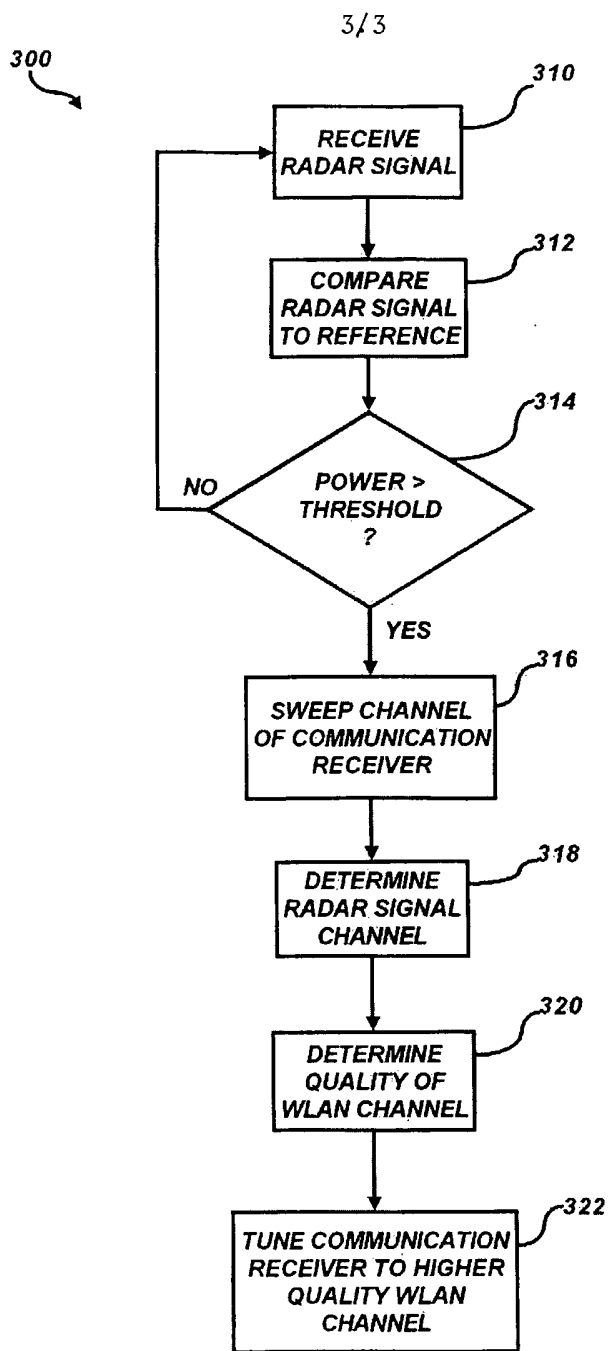

FIG. 3