

Dec. 14, 1937.

L. BOLLE

2,102,108

COMBUSTIBLE LIQUID LIGHTER

Filed July 22, 1936

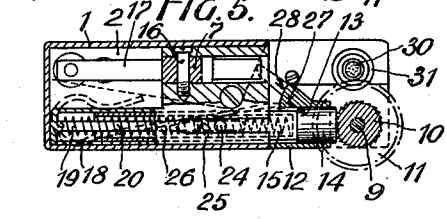
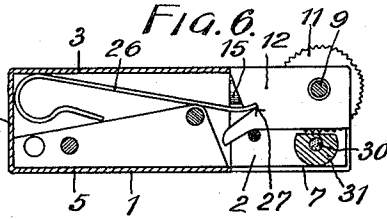
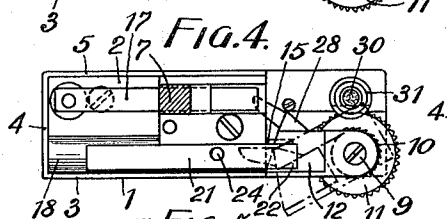
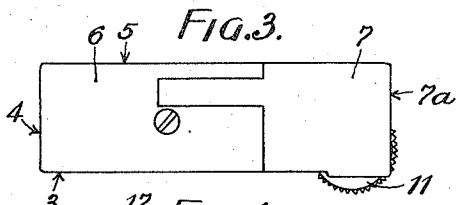
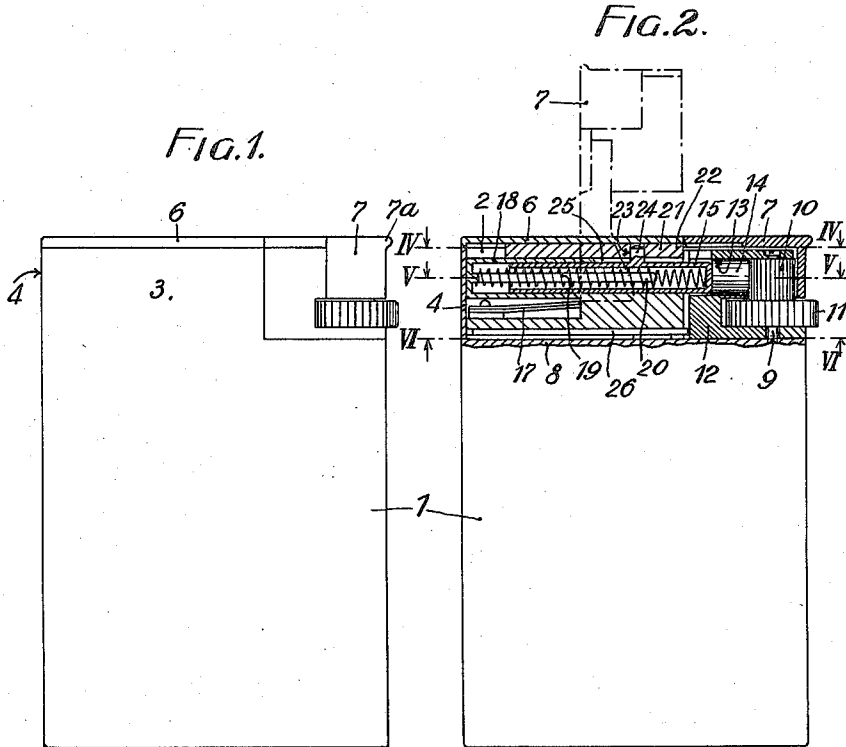

Inventor:
Leon Bolle
By E. H. Alexander
Att'y

UNITED STATES PATENT OFFICE

2,102,108

COMBUSTIBLE LIQUID LIGHTER

Léon Bolle, Geneva, Switzerland, assignor to
La Nationale Societe Anonyme, Geneva,
Switzerland

Application July 22, 1936, Serial No. 92,007
In Switzerland July 27, 1935

9 Claims. (Cl. 67—7.1)

The object of the invention is a combustible liquid lighter.

It comprises, as do other known combustible liquid lighters, an abrading wheel, a piece of pyrophoric material, a spring serving to put the piece of pyrophoric material in engagement with the abrading wheel, means by which the spring can be maintained mechanically in a position which prevents this engagement, a guiding device containing this piece of pyrophoric material and the spring. It is, however, distinguished by the fact that the guiding device is divided and presents no opening for laterally introducing the said piece of pyrophoric material and by the fact that means are provided to ensure a relative movement of the two parts on each side of the division such that the interior space of the guiding device becomes axially accessible so that the piece of pyrophoric material can be reached without disassembling parts and without great compression of the spring.

The accompanying drawing shows, by way of example, an embodiment of the combustible liquid lighter according to the invention:

Figs. 1 and 2 are a side elevation and a side elevation partly in section thereof.

Fig. 3 is a plan.

Figs. 4, 5 and 6 are sections on the lines IV—IV, V—V, VI—VI of Fig. 2, the last being viewed from below.

The lighter has the form of a right-angled prism having rectangular faces and is made of metal. It comprises a reservoir 1 containing the combustible liquid at its lower part, and a chamber 2 enclosing the lighting mechanism at its upper part. This latter is bounded by the lateral walls 3, 4, 5 of the body of the lighter, by an upper wall 6 of this body and by a movable hood 7, the walls of which are respectively in the same planes as the corresponding sides of the body, when it is closed. The hood 7 is pivoted at 16 and is maintained either in the closed position (Figs. 1, 2, 3 full lines) or in the open position (Fig. 2 broken lines) by a leaf spring 17.

The horizontal intermediate wall 8 of the lighter carries a vertical pin 9 near one of its ends. A steel abrading wheel 10, having ridges, a milled wheel 11 serving to move the abrading wheel by means of the finger and projecting slightly from the body at the base of the hood 7 and a support 12 are all mounted freely on the pin 9. A horizontal cylindrical passage 13 is formed in the support 12 where are housed a cylindrical piece 14 of pyrophoric material producing sparks when it is rubbed by the abrading

wheel 10, and the right hand extremity of a cylindrical hollow ram-bolt 15, applying the piece 14 onto this abrading wheel 10. The ram 15 is displaceable in a fixed cylindrical guide 18; between the two is interposed a helical spring 19 threaded on a stem 20 of the guide 18 so that it cannot bend in spite of its length, and hinder the easy sliding of the ram 15. The passage 13 and the guide 18 provide no opening for the lateral introduction of the piece 14.

The ram 15 can be displaced towards the left to bring it out of the passage 13 of the support 12, by acting on an edge 22 placed above 12 and forming part of a sliding member 21; this has a hole 23 in which is engaged a lug 24 of 15, passing into a longitudinal groove of the guide 18. The support 12 is maintained in its normal position corresponding to the working position of the group of elements abrading wheel-piece-spring, by the ram-bolt 15 which penetrates into its passage; it leaves the normal position to take up the position indicated in broken lines in Fig. 4 and corresponding to the position of accessibility of the piece 14 of the group, when the ram 15 is withdrawn, by means of a curved leaf spring 26 acting in a notch 27 formed therein.

The wick 30 emerging from a tube 31 coming from the reservoir 1 is at the side of the abrading wheel 10.

The operation of the embodiment described is as follows:

When not in use, the hood 7 is closed down on the body of the lighter and covers all the mechanism with the exception of part of the wheel 11. The support 12 occupies its normal position in which its exterior face is in the same plane as the rearward face of the body, and is maintained there by the ram 15, partially housed in its passage 13. The abrading wheel 10, the piece 14 and the spring 19 are in their operating positions.

If it is desired to use the lighter the hood 7 is raised to the position shown in broken lines in Fig. 2 by acting on its projecting edge 7a, the wheel 11 is turned and sparks are thus struck from the piece 14, which light the wick 30. This piece is maintained in contact with the abrading wheel 10, however much it is worn, by the ram 15 and the spring 19.

When it is required to examine, clean or change the piece 14, the hood 7 is lifted, the edge 22 is pushed to the left with the finger, which withdraws the sliding member 21 and the ram 15 which comes out of the passage 13 of the support 12; this immediately pivots forwardly under the action of the spring 26 and thus presents its pas-

sage 10 axially to the operator; it is maintained there by this spring 26, the movement of which towards the exterior is limited by meeting the wall 3. The projection 28 then acts on the ram 15 and maintains it as well as the spring 19 in a position in which 15, 19 are not in the way. The abrading wheel 10, the piece 14, the spring 19 are in their positions of accessibility of 14. The operator then has the piece 14 freely at his disposition. When the examination, cleaning or replacement is finished, the support 12 is pushed towards the rear; this support reassumes its normal position and is again maintained there by the ram 15.

15 The embodiment described presents various advantages.

When not in use, all the lighting mechanism is completely enclosed, with the only exception of a part of the milled wheel 11; the lighter has the complete form of a right angled prism with rectangular faces from which project only the edge 7a and a part of the wheel 11.

If it is desired to reach the piece 14, two very simple operations have to be carried out without any tools, lifting the hood 7, displacing the edge 21 towards the left, contrary to what takes place in other known lighters demanding a certain disassembling for this, such as removing one or more screws or a spring.

30 Replacing it in order for use is simply done by replacing the support 12 to its normal position.

The spring 19 remains generally fixed in space during these operations, being simply comprised in situ to a slight extent and not being moved with the ram 15, contrary to what takes place in other known lighters.

It can have a great length because it occupies a large part of the length of the reservoir, by reason of the fact that ram 15 is hollow; this permits it to act with an approximately constant force on the piece 14, whatever the length of this is.

In spite of that it is not housed in the reservoir 1, contrary to what obtains in other known lighters, this reservoir thus remains completely free for the reception of petrol and the wick 30 which fills it approximately completely.

The easy access to the piece 14 is obtained here by forming a division between the ram 15 and the piece 14 in the group abrading wheel-piece-ram-spring, so that the piece can be displaced in relation to the ram. This division could also be made between the abrading wheel 10 and the piece 14, in this case it can be arranged to displace either the abrading wheel in relation to the piece or the piece in relation to the abrading wheel, the position of which in space is not changed, in order to afford access to the said piece.

The arrangement of the lighting mechanism, the form of the lighter, etc. can differ from those which have been indicated.

65 What I claim is:

1. A lighter comprising abrading means, a pivotally mounted support having a guide therein, a piece of pyrophoric material slidably mounted in said guide adapted to cooperate with said abrading means, resilient means normally urging said pyrophoric material towards said abrading means and extending into said guide in order to hold said support from pivoting and means for retracting said resilient means from said guide in order to permit pivoting of said support

whereby said piece of pyrophoric material may be replaced.

2. A lighter comprising abrading means, a pivotally mounted support having a guide therein, a piece of pyrophoric material slidably mounted in said guide adapted to cooperate with said abrading means, means normally urging said pyrophoric material into contact with said abrading means and extending into said guide to maintain said guide in alignment therewith, means normally urging said support and guide out of alignment with said means urging said material into contact with said abrading means and means for withdrawing said urging means for said material from said guide so that said support and guide are pivoted out of alignment whereby the pyrophoric material may be replaced.

3. A lighter comprising abrading means, a pivotally mounted support having a guide therein, a piece of pyrophoric material slidably mounted in said guide adapted to cooperate with said abrading means, means normally urging said pyrophoric material into contact with said abrading means and extending into said guide to maintain said guide in alignment therewith, means normally urging said support and guide out of alignment with said means urging said material into contact with said abrading means and means for withdrawing said urging means for said material from said guide so that said support and guide are pivoted out of alignment whereby the pyrophoric material may be replaced, and means for holding said means urging said pyrophoric material into contact with said abrading means in withdrawn position during the time said guide is out of alignment therewith.

4. A lighter comprising an abrading wheel, means for rotating said wheel, a pivotally mounted support, a piece of pyrophoric material slidably mounted in said support adapted to cooperate with said wheel, resilient means urging said material towards said wheel and locking said support from pivoting and means for retracting said resilient means and thereby permitting pivoting of said support whereby said material may be replaced.

5. A lighter comprising an abrading wheel, means for rotating said wheel, a pivotally mounted support, a piece of pyrophoric material slidably mounted in said support adapted to cooperate with said wheel, resilient means urging said material towards said wheel and locking said support from pivoting and means for retracting said resilient means and thereby permitting pivoting of said support whereby said material may be replaced, and means for holding said resilient means in retracted position when said support has been unlocked from said resilient means.

6. A lighter comprising an abrading wheel, means for rotating said wheel, a pivotally mounted support, a piece of pyrophoric material slidably mounted in said support adapted to cooperate with said wheel, telescopic means urging said material towards said wheel and preventing said support from pivoting and means for withdrawing said telescopic means from said material and said support whereby said material may be replaced.

7. A lighter comprising an abrading wheel, means for rotating said wheel, a pivotally mounted support, a piece of pyrophoric material slidably mounted in said support adapted to cooperate with said wheel, resilient telescopic means urging said material towards said wheel and locking said support in alignment therewith, means

normally urging said support out of alignment and means for collapsing said telescopic means away from said material and support whereby said support is pivoted out of alignment in order that said material may be replaced or repaired.

8. A lighter comprising an abrading wheel, means for rotating said wheel, a pivotally mounted support, a piece of pyrophoric material slidably mounted in said support adapted to cooperate with said wheel, resilient telescopic means urging said material towards said wheel and locking said support in alignment therewith, means normally urging said support out of alignment and means for collapsing said telescopic means away from said material and support whereby

said support is pivoted out of alignment in order that said material may be repaired or replaced, and a pivoted hood member enclosing said support when locked in position.

9. A lighter comprising an abrading wheel, a shaft upon which said wheel rotates, a support pivoted on said shaft, a piece of pyrophoric material slidably mounted in said support adapted to cooperate with said wheel, resilient means urging said material towards said wheel and locking said support from pivoting and means for retracting said resilient means and thereby permitting pivoting of said support whereby said material may be replaced.

LÉON BOLLE. 15