

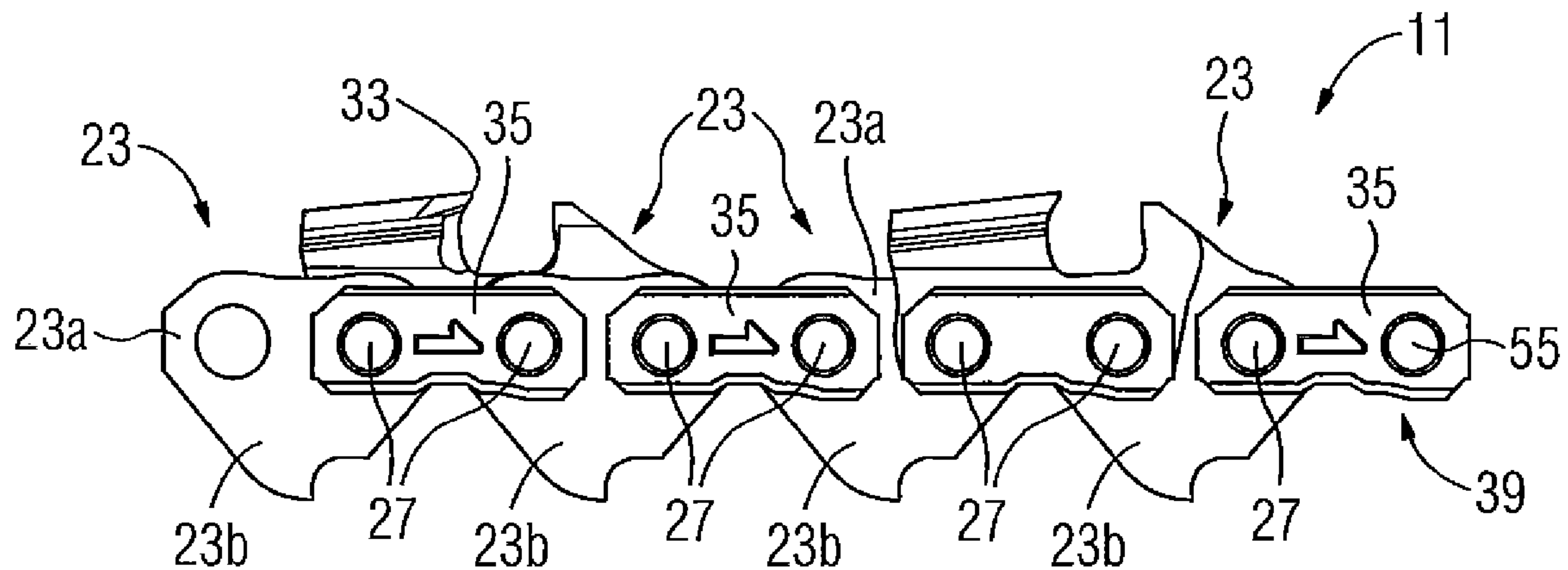

(86) **Date de dépôt PCT/PCT Filing Date:** 2013/03/27  
 (87) **Date publication PCT/PCT Publication Date:** 2014/10/02  
 (45) **Date de délivrance/Issue Date:** 2018/07/17  
 (85) **Entrée phase nationale/National Entry:** 2015/09/25  
 (86) **N° demande PCT/PCT Application No.:** EP 2013/056591  
 (87) **N° publication PCT/PCT Publication No.:** 2014/154268

(51) **Cl.Int./Int.Cl. B27B 33/14** (2006.01),  
**B23D 65/00** (2006.01)  
 (72) **Inventeur/Inventor:**  
LIKIDOU, PANAGIOTA, SE  
 (73) **Propriétaire/Owner:**  
HUSQVARNA AB, SE  
 (74) **Agent:** BRION RAFFOUL

(54) **Titre : CHAÎNE DE SCIE A CHAINON LUBRIFIANT**  
 (54) **Title: SAW CHAIN WITH LUBRICATING LINKAGE**



(57) **Abrégé/Abstract:**

A chain saw (1) comprises an endless saw chain (11) and a saw bar (9) with a peripheral track for the saw chain (11). The saw chain (11) has a plurality of chain links and/or chain link components, in particular cutter links (29), drive links (23) and/or tie straps (35). At least one of the tie straps (35) comprises a cavity (43) or notch arranged at a first lateral surface (45) thereof. The first lateral surface (45) faces a lateral surface of at least one adjacent chain link or chain link component. In order to provide a saw chain movement with minimized wear and in addition a further reduction of the tendency of the chain links to flex during operation, the cavity (43) or notch is manufactured during a deforming process, serves as a reservoir for a lubricant, in particular for oil, for lubrication of the saw chain (11) and comprises an extension essentially in the driving direction of the saw chain (11) and, at least in part, a dilatation, an extension and/or a branching essentially extending in the direction perpendicular thereto.

(12) INTERNATIONAL APPLICATION PUBLISHED UNDER THE PATENT COOPERATION TREATY (PCT)

(19) World Intellectual Property  
Organization  
International Bureau(10) International Publication Number  
**WO 2014/154268 A1**(43) International Publication Date  
2 October 2014 (02.10.2014)

- (51) **International Patent Classification:**  
*B27B 33/14* (2006.01)    *B23D 65/00* (2006.01)
- (21) **International Application Number:**  
PCT/EP2013/056591
- (22) **International Filing Date:**  
27 March 2013 (27.03.2013)
- (25) **Filing Language:** English
- (26) **Publication Language:** English
- (71) **Applicant:** HUSQVARNA AB [SE/SE]; Drottninggatan 2, S-56182 Huskvarna (SE).
- (72) **Inventor:** LIKIDOU, Panagiota; Idrottsvägen 15, S-554 54 Jönköping (SE).
- (74) **Agent:** FINKELE, Rolf; c/o GARDENA Manufacturing GmbH, Hans-Lorenser-Strasse 40, 89079 Ulm (DE).
- (81) **Designated States** (*unless otherwise indicated, for every kind of national protection available*): AE, AG, AL, AM, AO, AT, AU, AZ, BA, BB, BG, BH, BN, BR, BW, BY, BZ, CA, CH, CL, CN, CO, CR, CU, CZ, DE, DK, DM,

DO, DZ, EC, EE, EG, ES, FI, GB, GD, GE, GH, GM, GT, HN, HR, HU, ID, IL, IN, IS, JP, KE, KG, KM, KN, KP, KR, KZ, LA, LC, LK, LR, LS, LT, LU, LY, MA, MD, ME, MG, MK, MN, MW, MX, MY, MZ, NA, NG, NI, NO, NZ, OM, PA, PE, PG, PH, PL, PT, QA, RO, RS, RU, RW, SC, SD, SE, SG, SK, SL, SM, ST, SV, SY, TH, TJ, TM, TN, TR, TT, TZ, UA, UG, US, UZ, VC, VN, ZA, ZM, ZW.

- (84) **Designated States** (*unless otherwise indicated, for every kind of regional protection available*): ARIPO (BW, GH, GM, KE, LR, LS, MW, MZ, NA, RW, SD, SL, SZ, TZ, UG, ZM, ZW), Eurasian (AM, AZ, BY, KG, KZ, RU, TJ, TM), European (AL, AT, BE, BG, CH, CY, CZ, DE, DK, EE, ES, FI, FR, GB, GR, HR, HU, IE, IS, IT, LT, LU, LV, MC, MK, MT, NL, NO, PL, PT, RO, RS, SE, SI, SK, SM, TR), OAPI (BF, BJ, CF, CG, CI, CM, GA, GN, GQ, GW, ML, MR, NE, SN, TD, TG).

**Published:**

— with international search report (Art. 21(3))

(54) Title: CHAIN SAW

FIG 3

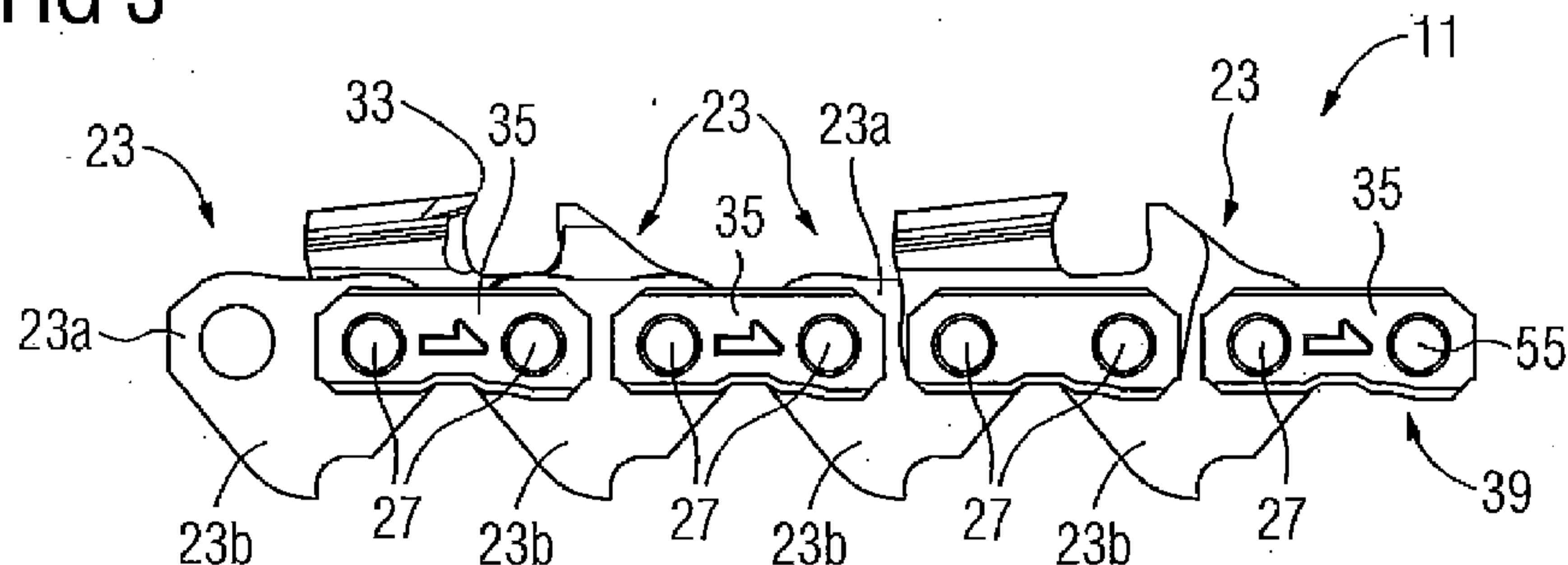

(57) **Abstract:** A chain saw (1) comprises an endless saw chain (11) and a saw bar (9) with a peripheral track for the saw chain (11). The saw chain (11) has a plurality of chain links and/or chain link components, in particular cutter links (29), drive links (23) and/or tie straps (35). At least one of the tie straps (35) comprises a cavity (43) or notch arranged at a first lateral surface (45) thereof. The first lateral surface (45) faces a lateral surface of at least one adjacent chain link or chain link component. In order to provide a saw chain movement with minimized wear and in addition a further reduction of the tendency of the chain links to flex during operation, the cavity (43) or notch is manufactured during a deforming process, serves as a reservoir for a lubricant, in particular for oil, for lubrication of the saw chain (11) and comprises an extension essentially in the driving direction of the saw chain (11) and, at least in part, a dilatation, an extension and/or a branching essentially extending in the direction perpendicular thereto.



WO 2014/154268 A1

Title: SAW CHAIN WITH LUBRICATING LINKAGE

**Description**

The invention relates to the field of chain saws and in particular to chain saws comprising an endless saw chain and a saw bar with a peripheral track for the saw chain.

5 Saw chains and saw bar assemblies for chain saws are subjected to high mechanical loads during operation. The friction of the individual movable parts against each other causes wear. Generally, such saw chain and saw bar assembly includes essentially a saw bar having a peripheral track for the saw chain, the saw bar in particular having a guiding groove formed along the  
10 outer longitudinal edge thereof in which the saw chain runs. The saw chain comprises a plurality of chain links and/or chain link components, in particular including cutter links, drive links and/or tie straps. It is also known that the drive links have respective rakers or tangs which are guided in the guiding groove. With the chain saw in operation the pivotally connected chain links or  
15 chain link components rub against each other in particular in the region of their pivot connections. Friction forces occur in the region of the peripheral track of the saw bar and the sliding surfaces of the individual chain link which slide on this peripheral track. In case of a guide bar having a guiding groove friction forces also occur in the region of the guiding groove between the side  
20 walls of the stationary fixed guiding groove and the side surfaces of the running chain links.

In order to reduce friction forces and the related signs of wear lubrication devices are known for lubricating the existing friction and rubbing pairs wherein  
25 a lubricant, in particular a lubrication oil, is introduced into the guiding groove where it is taken up by the drive links, in particular by the rakers or tangs thereof. With the running saw chain and the centrifugal forces caused by its

circular movement the lubricant is driven also to medium and outer portions of the chain links, in particular also to their pivot connections. Aforementioned centrifugal forces, however, also cause the lubricant being driven to the outer regions of the chain links and being thrown off too rapidly with the effect of an insufficient lubrication. As a remedial measure, DE 32 07 326 A1 discloses an arrangement on a chain saw for lubricating the saw chain, which comprises groove-like oil guides arranged at the inner surfaces of saw chain tie straps and preferably also on saw chain cutter links. As a result, the groove-like oil guides serve as a reservoir for lubrication oil and the pivot connections and in particular connecting pins connecting two adjacent chain links can be supplied with the lubrication oil.

It is an object of the present invention to further improve lubrication of the saw chain, in particular pivot connections thereof, thereby also reducing the tendency of the chain links to flex during operation. Another object of the invention is to provide information to the user of the chain saw related to the saw chain or the assembly or operation thereof.

In a first aspect, this document discloses a chain saw comprising an endless saw chain and a saw bar with a peripheral track for the saw chain, the saw chain comprising a plurality of drive links, each of said drive links comprising an upper portion and a lower portion, wherein the lower portion is configured to slide within a guiding groove of the saw bar; and a plurality of tie straps configured to slide along an edge of the guiding groove, at least one tie strap having one of: a cavity and a notch, arranged at a first lateral surface thereof, the first lateral surface facing a lateral surface of at least one adjacent drive link of said plurality of drive links, wherein the one of: the cavity and the notch: serves as a reservoir for a lubricant for lubrication of the saw chain; and comprises a first portion and a second portion, the first portion extending in a driving direction of the saw chain and the second portion extending substantially in a direction perpendicular to the driving direction, wherein the at least one tie strap further comprises an embossment arranged at a second lateral surface, opposite to the first lateral surface.

In a second aspect, this document discloses a saw chain for a chain saw, the saw chain comprising a plurality of drive links, each of said drive links comprising an

2a

upper portion and a lower portion, wherein the lower portion is configured to slide within a guiding groove of a saw bar of the chain saw; and a plurality of tie straps configured to slide along an edge of the guiding groove, at least one tie strap having one of: a cavity and a notch, arranged at a first lateral surface thereof, the  
5 first lateral surface facing a lateral surface of at least one adjacent drive link of said plurality of drive links, wherein the one of: the cavity and the notch serves as a reservoir for a lubricant for lubrication of the saw chain; and comprises a first portion and a second portion, the first portion extending in a driving direction of the saw chain and the second portion extending substantially in a direction  
10 perpendicular to the driving direction, wherein the at least one tie strap further comprises an embossment arranged at a second lateral surface, opposite to the first lateral surface.

A chain saw according to the invention comprises an endless saw chain having a  
15 plurality of chain links and/or chain link components and a saw bar having a peripheral track for the saw chain. The plurality of chain links and/or chain link components comprise at least one tie strap having a cavity or notch arranged at a first lateral surface thereof for lubrication of the chain saw. The first lateral surface of the tie strap faces a lateral surface of at least one adjacent chain link  
20 or chain link component. The cavity or notch is manufactured during a deforming process and serves as a reservoir for a lubricant, in par-

5 ticular lubrication oil. With such reservoir lubricant can be kept for a while and gradually fed to surfaces that are in a sliding movement against each other while the saw chain is moving. When manufacturing the cavity or notch by using a deforming process the material of the tie strap, thus the tie strap itself, is obtaining an increased stiffness, and yet reducing the tendency of the saw chain to flex during its rotational movement. The cavity or notch is further characterized by an extension essentially in the driving direction of the saw chain and by a dilatation, an extension and/or branching essentially in lateral direction, i.e. in the direction perpendicular to the driving direction. Having 10 extensions in two directions, the cavity or notch is able to collect sufficient lubricant for the lubrication of the chain saw, and further, due to the above-mentioned manufacturing process, the stiffness, in particular the torsion stiffness, is further increased.

15 Different structures for the cavity or notch with its extensions in two directions are conceivable. The cavity or notch may have a large-scale dilatation in the direction perpendicular to the driving direction. In case of an only partly extension, dilatation and/or branching the cavity or notch may be T-, L- or cross-shaped.

20

The deforming process may be of any kind of manufacturing process which brings material strength about, what may be coining, punching, embossing, bead forming, rolling and/or stamping. Such kind of deforming process is also very cheap and can be quickly executed.

25

The deforming process may also be executed in a way resulting in not only arranging the cavity or notch on the first lateral surface which is directly exposed to that manufacturing step, but in also receiving a respective marking, i. e. an embossment or elevation, on a second lateral surface opposite to the 30 first lateral surface, which embossment or elevation may be essentially of the same shape as the cavity or notch. When having an uneven surface on both sides the stiffness of tie strap is yet further increased.

The tie strap may also comprise two rivet bores for its connection with adjacent chain links or chain link components and the cavity or notch may be arranged in the area between the rivet bores. In this way the tie strap is reinforced mainly in its central sector where the tendency of torsion is usually notably high.

A preferred embodiment of the invention provides a cavity or notch, or at least a portion thereof, which comprises a symbol, such symbol providing information to a user of the chain saw. The information providing of the symbol may be of any kind of message that might be helpful for the user to get an indication of the whole product or any specific component thereof, e.g. the name or a mark, logo or code of the producer of the chain saw or of the fitted saw chain. Alternatively, the user might get also information of the use of the product or component or its arrangement on the chain saw.

15

In a preferred embodiment, the user gets an indication of the driving direction of the saw chain. This may be arranged by a cavity or notch that comprises a triangular symbol. A first corner or cone end of such a symbol may indicate the driving direction or direction of rotation of the saw chain. In case of a replacement of the respective chain link or chain link component, i.e. of the tie strap, or of the whole saw chain the user will be informed in that way how to fit this part into the saw chain or the saw chain into the chain saw.

The first corner or cone end of the triangular symbol may terminate at or close by a first rivet bore arranged at the tie strap. Thus, the lubricant in the triangular cavity is stored close to the pivoting connection of the tie strap with an adjacent chain link or chain link component and the lubricant can be gradually delivered also to the pivoting connection.

Preferably, the cavity or notch further comprises a straight line channel. Such straight line channel may terminate with a first end thereof at or close by a second rivet bore arranged at the tie strap, particularly disposed at a distance from the first rivet bore. In order to provide a contiguous cavity or notch at

30

the tie strap, the straight line channel may terminate with its second end at the triangular symbol, particularly opposite to the first corner or cone end thereof. That way, the connected channel and triangular symbol form a continuous arrow-shaped cavity or notch.

5

In a most preferred embodiment, the straight line channel terminates with its second end at a second corner of the triangular symbol, which second corner may form – at least approximately – a right angle. Such a combination of channel and triangular symbol forms an axially divided arrow with a continuous longitudinal extension from the first end of the channel to the cone end of the arrowhead. This shape of symbol indicating the direction of saw chain rotation makes best possible use of the area between the two rivet bores, thereby providing to a large extent an evenly distributed lubricant and further providing a tie strap with a notably high torsional stiffness.

15

The invention will be described more fully hereinafter with reference to the accompanying drawings, in which

- Fig. 1 is a schematic view of a chain saw with a part of a housing cut out;
- Fig. 2 is an enlarged cross-sectional view of a cutting assembly of Fig. 1;
- Fig. 3 is a side elevation view of a segment of a saw chain;
- Fig. 4 is a perspective view of the segment of the chain saw of Fig. 3, but arranged on a saw bar;
- Figs. 5a to 5d are side elevation and perspective views of the inner side and the outer side of tie straps as used in the saw chain of Fig. 3.

Fig. 1 shows a schematic view of a chain saw 1 with a housing 3 in which a driving motor (not shown) is mounted. For guiding the chain saw 1 two handles 5a, 5b are attached to the housing 3. On one end of the housing 3, opposite to a rearward handle 5b, the chain saw 1 has a cutting assembly 7 which includes a saw bar 9 and a saw chain 11. In the housing 3 a drive sprocket 13 is provided for driving the saw chain 11. The drive sprocket 13 is driven by the driving motor. The saw chain 11 runs over the drive sprocket 13 and over upper, end and lower edges 15, 17, 19 of the saw bar 9.

Fig. 2 shows, in an enlarged and more detailed view, a cross section taken through the cutting assembly 7 of Fig. 1 according to intersection line II-II. In the embodiment shown, the saw bar 9 has a guiding groove 21 in the region of its peripheral edges 15, 17, 19. A drive link 23 is shown in cross section and comprises an upper portion 23a and a lower portion 23b. The upper portion 23a is arranged outside of the guiding groove 21 and the lower portion 23b is arranged inside the guiding groove 21 and is guided during its movement by the inner walls 25a, 25b of the guiding groove 21.

The drive link 23 is pivotally connected via a rivet 27 to a cutting link 29 which comprises a cutting tooth 31 with a cutting tip 33 and which is arranged at a first side of the upper portion 23a of the drive link 23. The cutting link 29 is completed by a tie strap 35 which is arranged at a second side of the upper portion 23a of the drive link 23 opposite to the first side.

Fig. 3 shows, in a side view, a segment of a saw chain 11 with a number of drive links 23 that is pivotally connected by a rivet 27 alternately to a pair of cutting link 29 / tie strap 35 and a pair of both-sided tie straps 35 constituting a connecting link 37. The cutting links 29 are alternately arranged so that their respective cutting tips 33 are alternately on both sides of a longitudinal section plane of the saw chain 11. As can be easily understood, the segment shown in Fig. 3 is of periodic way. On each side of the series of drive links 23 of the chain saw 11, a cutting link 29 is followed by three tie straps 35.

Fig. 4 shows the saw chain segment of Fig. 3, however, inserted in the guiding groove 21 of the saw bar 9. Both cutting links 29 and tie straps 35 are each equipped with a bottom-sided sliding surface 39 for sliding on the rails 41 of the guiding groove 21.

5

In order to minimize wear during the movement of the saw chain 11 oil lubrication is provided. With the movement the individual parts of the cutting assembly 7 execute sliding or rubbing movements against each other for which lubricant is conducted into the guiding groove 21 for the lubrication of the individual parts. Rubbing pairs, in particular, are formed between tie straps 35 and drive links 23 in the region of their pivotal connection or between the rivets 27 and the inner surfaces of the bores of the drive link 23. Sufficient lubrication of such rubbing pairs is important for longevity of the chain saw 11.

15 During the rotational movement of the saw chain 11 the lubricant is taken up by the lower portions 23b of the drive links 23 and, due to centrifugal force while moving in particular along the end edge 17 of the saw bar 9, slipped to the upper portions 23a, thereby moved also into the gaps between drive links 23 and cutting links 29 or tie straps 35, respectively. In order to avoid immediate further catapulting of all the lubricant to the outside each of the tie  
20 straps 35 comprise a cavity 43 that acts as a reservoir for lubrication oil, preventing oil from being thrown off the saw chain 11 by centrifugal force.

As can be best understood from the disclosure of Figs. 5a to 5d showing the inner 45 and outer 47 sides of a tie strap 35, the cavity 43 is implemented during a deforming process which could be one of the processes coining, punching, embossing, bead forming, rolling or stamping. Such a kind of deforming process results not only in receiving a cavity 43 on the inner side 45 (Figs. 5b, 5d) but also in receiving a respective embossment 49 on the outer  
30 side 47 (Figs. 5a, 5c) of the tie strap 35. The cavity 43 and also the related embossment 49 are shaped as a longitudinally halved arrow with a horizontally arranged arrow shaft 51 and an adjacent halved arrowhead 53 which, when

fitted in the saw chain 11, is directed away from the guiding groove 21 of the saw bar 9.

The arrangement is realized in that the halved arrow 51, 53 indicates the direction of rotation of the saw chain 11. By reason of having tie straps 35 arranged on both sides of the saw chain 11, pairs of mirror-inverted tie straps 35 need to be provided for a respective correct indication of the direction of rotation. The halved arrow 51, 53 is arranged between two bores 55 provided for connecting the tie strap 35 with the adjacent drive links 23 by rivets 27, however, the longitudinal extension of the halved arrow 51, 53 is smaller than the distance between the two bores 55.

The depth of the cavity 43 may be within the range of 0.025 to 0.4 mm, preferably in the range of 0.1 to 0.2 mm, wherein for an equal quantity distribution of the lubricant the depth of the arrow shaft 51 may be greater than the depth of the arrowhead 53. However, in the embodiment shown in Figs. 1 to 5 the cavity 43 is of a uniform depth.

## List of reference numerals

	1	chain saw
5	3	housing
	5a, 5b	handles
	7	cutting assembly
	9	saw bar
	11	saw chain
10	13	drive sprocket
	15	upper edge
	17	end edge
	19	lower edge
	21	guiding groove
15	23	drive link
	23a, 23b	upper, lower portion of drive link
	25a, 25b	inner walls of guiding groove
	27	rivet
	29	cutting link
20	31	cutting tooth
	33	cutting tip
	35	tie strap
	37	connecting link
	39	sliding surface
25	41	rails
	43	cavity
	45	tie strap inner side
	47	tie strap outer side
	49	embossment
30	51	arrow shaft
	53	arrowhead
	55	bore

What is claimed is:

1. A chain saw comprising an endless saw chain and a saw bar with a peripheral track for the saw chain, the saw chain comprising a plurality of drive links, each of said drive links comprising an upper portion and a lower portion, wherein the lower portion is configured to slide within a guiding groove of the saw bar; and a plurality of tie straps configured to slide along an edge of the guiding groove, at least one tie strap having one of: a cavity and a notch, arranged at a first lateral surface thereof, the first lateral surface facing a lateral surface of at least one adjacent drive link of said plurality of drive links, wherein the one of: the cavity and the notch:
  - serves as a reservoir for a lubricant for lubrication of the saw chain; and
  - comprises a first portion and a second portion, the first portion extending in a driving direction of the saw chain and the second portion extending substantially in a direction perpendicular to the driving direction,wherein the at least one tie strap further comprises an embossment arranged at a second lateral surface, opposite to the first lateral surface.
2. The chain saw of claim 1, wherein the one of: the cavity and the notch is one of: T-shaped, L-shaped and cross-shaped.
3. The chain saw of one of claims 1 and 2, wherein the one of: the cavity and the notch is manufactured during a deforming process, the deforming process comprising at least one of: a coining process, a punching process, a embossing process, a bead forming process, a rolling process and a stamping process.
4. The chain saw of any one of claims 1 to 3, wherein the embossment is of the same shape as the one of: the cavity and the notch.

30

5. The chain saw of any one of claims 1 to 4, wherein the tie strap comprises two rivet bores for the tie strap to connect with one of: adjacent chain links and adjacent chain link components and wherein the one of: the cavity and the notch is arranged in the area between the rivet bores.  
5
6. The chain saw of any one of claims 1 to 5, wherein at least a portion of the one of: the cavity and the notch comprises a symbol, thereby providing information to a user of the chain saw.
- 10 7. The chain saw of claim 6, wherein the symbol indicates the driving direction of the saw chain.
8. The chain saw of one of claim 6 and 7, wherein the symbol is triangular.
- 15 9. The chain saw of claim 8, wherein a first corner of the triangular symbol terminates at a location that is one of: close by a rivet bore arranged at the tie strap and at the rivet bore arranged at the tie strap.
10. The chain saw of any one of claims 6 to 9, wherein the one of: the cavity  
20 and the notch further comprises a straight line channel.
11. The chain saw of claim 10, wherein the channel terminates with a first end located at one of: at a rivet bore arranged at the tie strap and close by the rivet bore arranged at the tie strap.  
25
12. The chain saw of claim 11, wherein the channel terminates with a second end at the symbol, thereby forming one of: a continuous arrow-shaped cavity and a continuous arrow-shaped notch.
- 30 13. The chain saw of claim 12, wherein the channel terminates with the second end at a second corner of the triangular symbol, the second corner forming at least approximately a right angle, thereby forming an axially divided

arrow with a continuous longitudinal extension from the first end of the channel to the cone end of the arrowhead.

14. A saw chain for a chain saw, the saw chain comprising a plurality of drive  
5 links, each of said drive links comprising an upper portion and a lower  
portion, wherein the lower portion is configured to slide within a guiding  
groove of a saw bar of the chain saw; and a plurality of tie straps  
configured to slide along an edge of the guiding groove, at least one tie  
strap having one of: a cavity and a notch, arranged at a first lateral surface  
10 thereof, the first lateral surface facing a lateral surface of at least one  
adjacent drive link of said plurality of drive links, wherein the one of: the  
cavity and the notch
- serves as a reservoir for a lubricant for lubrication of the saw chain; and
  - comprises a first portion and a second portion, the first portion  
15 extending in a driving direction of the saw chain and the second portion  
extending substantially in a direction perpendicular to the driving  
direction,
- wherein the at least one tie strap further comprises an embossment arranged  
at a second lateral surface, opposite to the first lateral surface.
- 20
15. The saw chain of claim 14, wherein the one of: the cavity and the notch is  
shaped as one of: T-shaped, L-shaped and cross-shaped.
16. The saw chain of one of claims 14 and 15, wherein the one of: the cavity  
25 and the notch is manufactured during a deforming process, the deforming  
process being at least one of: a coining process, a punching process, a  
embossing process, a bead forming process, a rolling process and a  
stamping process.
- 30 17. The saw chain of any one of claims 14 to 16, wherein the embossment is of  
a same shape as the one of: the cavity and the notch.

18. The saw chain of any one of claims 14 to 17, wherein the tie strap comprises two rivet bores for the tie strap to connect with one of: adjacent chain links and chain link components and wherein the one of: the cavity and the notch is arranged in the area between the two rivet bores.
- 5
19. The saw chain of any one of claims 14 to 18, wherein at least a portion of the one of: the cavity and the notch comprises a symbol, the symbol thereby providing information to a user of the chain saw.
- 10
20. The saw chain of claim 19, wherein the symbol indicates the driving direction of the saw chain.
21. The saw chain of one of claims 19 and 20, wherein the symbol is triangular.
- 15
22. The saw chain of claim 21, wherein a first corner of the triangular symbol terminates at a location that is one of: close to a rivet bore arranged at the tie strap and at the rivet bore arranged at the tie strap.
23. The saw chain of any one of claims 19 to 22, wherein the one of: the cavity and the notch further comprises a straight line channel.
- 20
24. The saw chain of claim 23, wherein the channel terminates with a first end that is located at one of: at a rivet bore arranged at the tie strap and close to the rivet bore arranged at the tie strap.
- 25
25. The saw chain of claim 24, wherein the channel terminates with a second end at the symbol, thereby forming one of: a continuous arrow-shaped cavity and a continuous arrow-shaped notch.
- 30
26. The saw chain of claim 25, wherein the channel terminates with the second end at a second corner of the triangular symbol, the second corner forming at least approximately a right angle, thereby forming an axially divided

arrow with a continuous longitudinal extension from the first end of the channel to the cone end of the arrowhead.

FIG 1

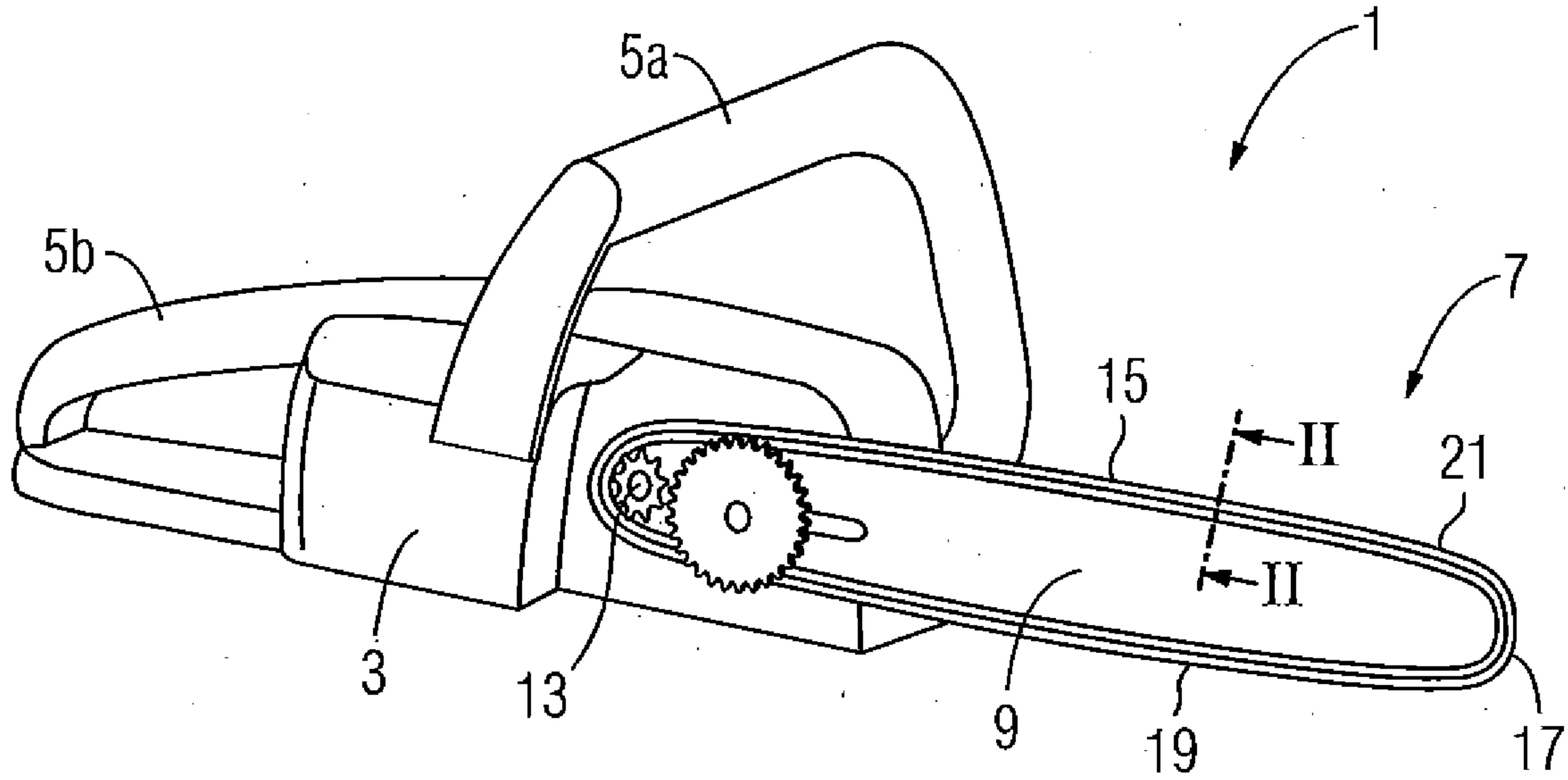

FIG 2

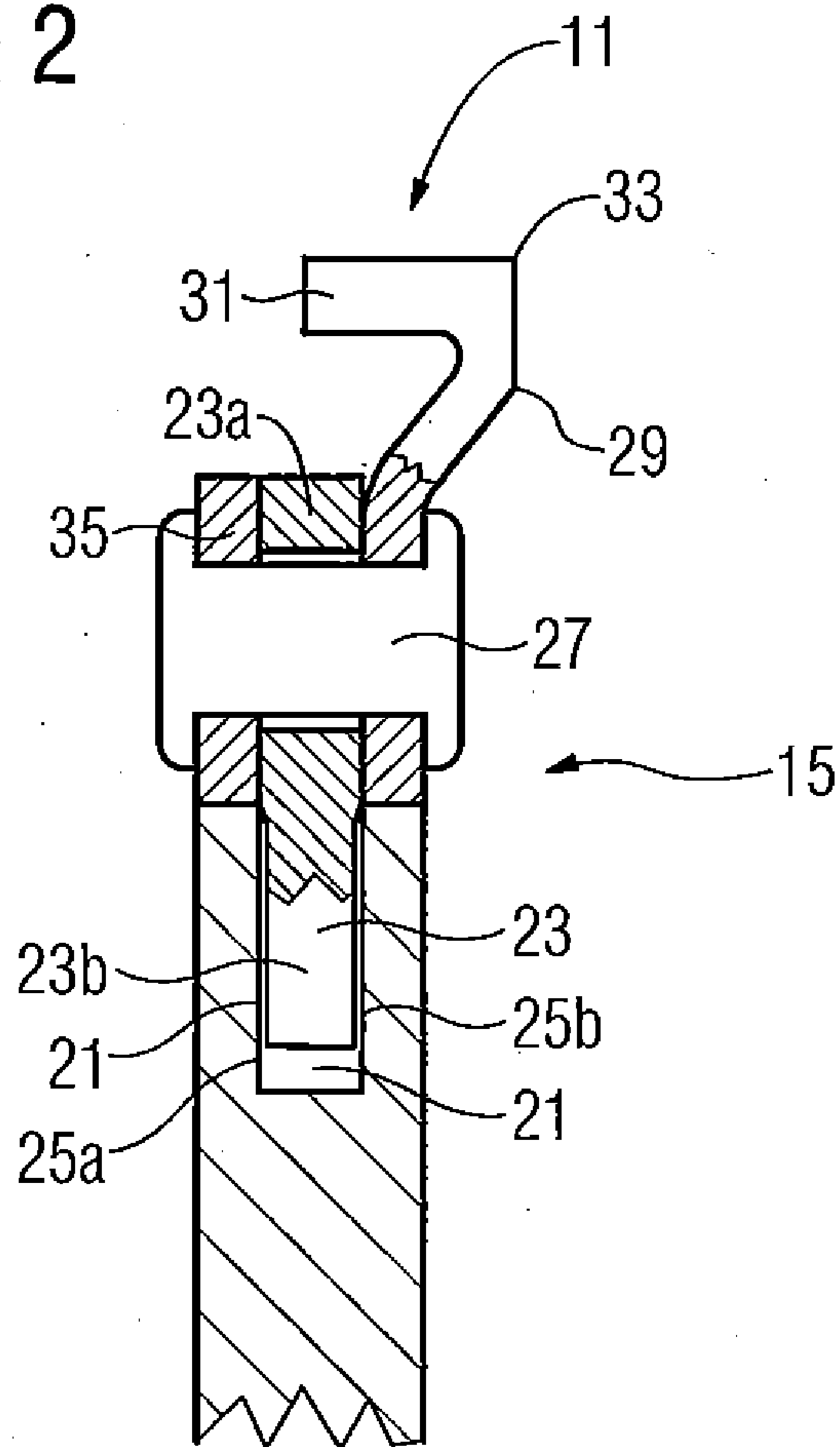

FIG 3

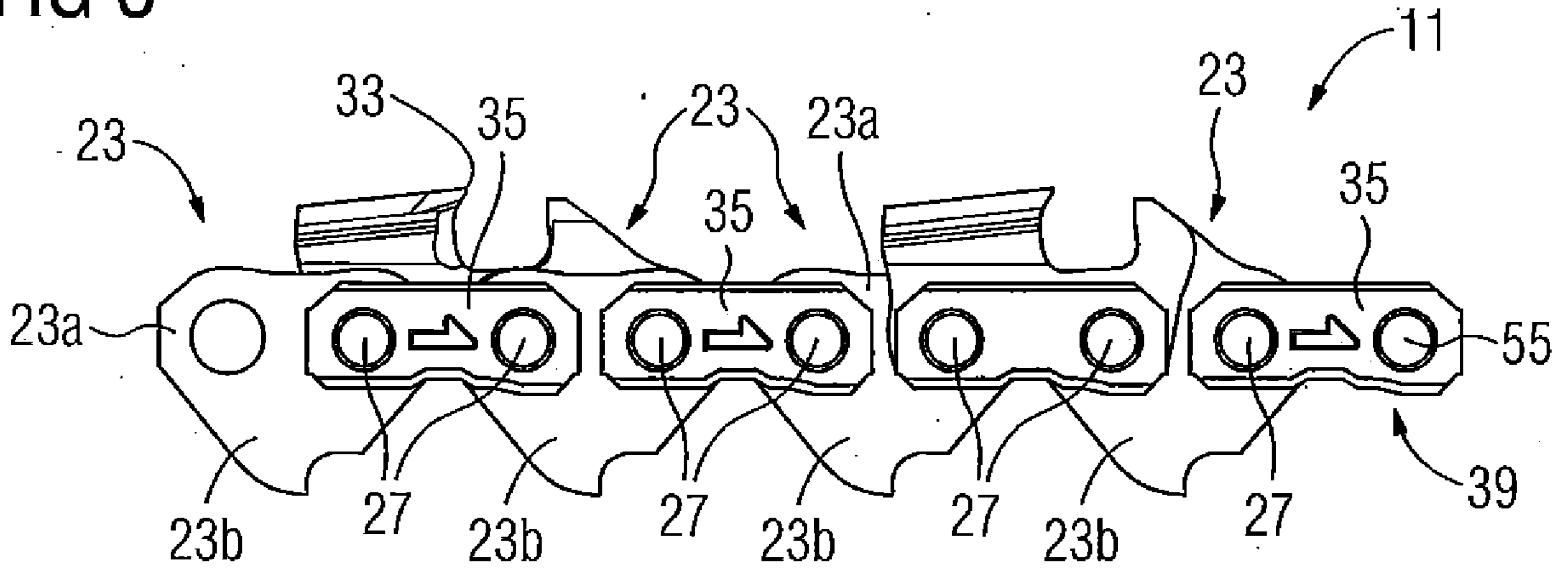

FIG 4

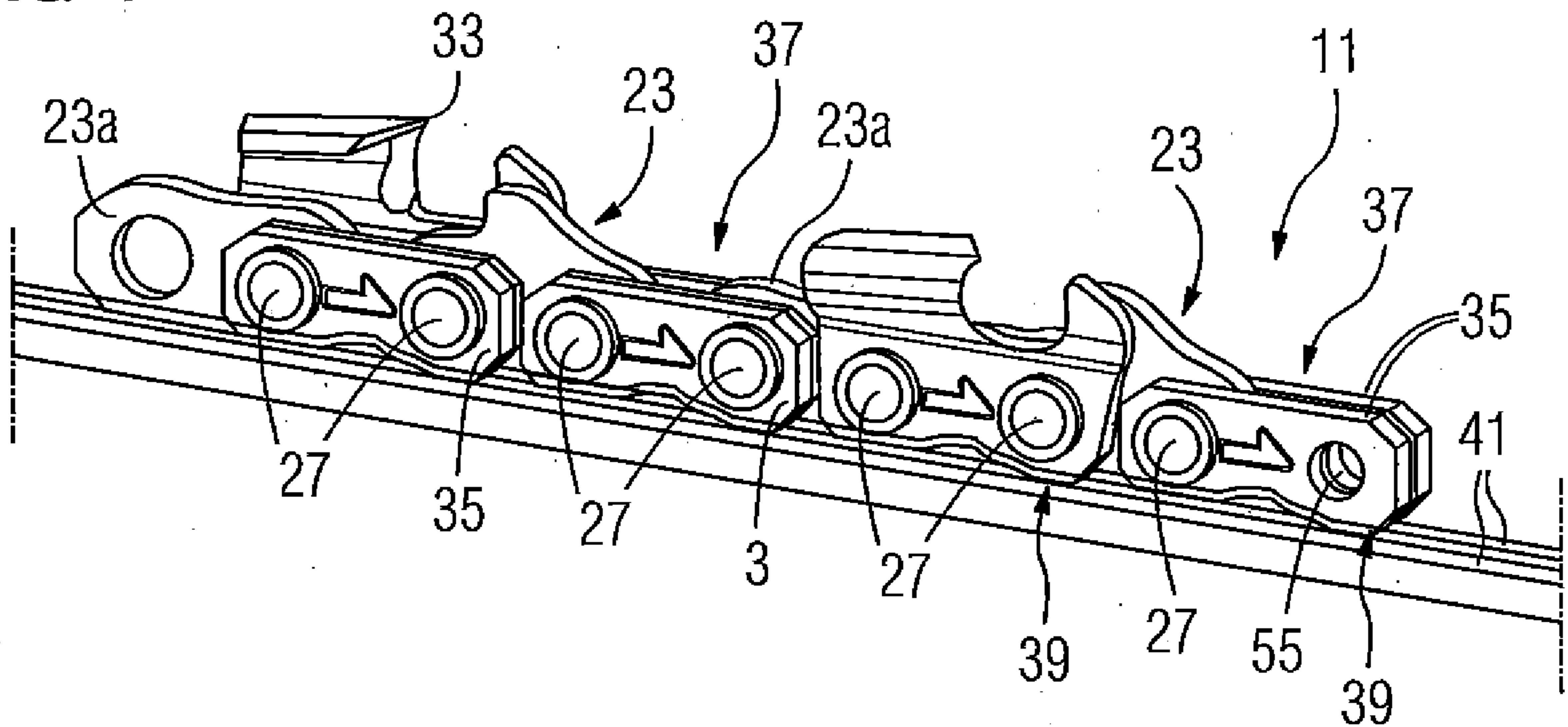

FIG 5

