

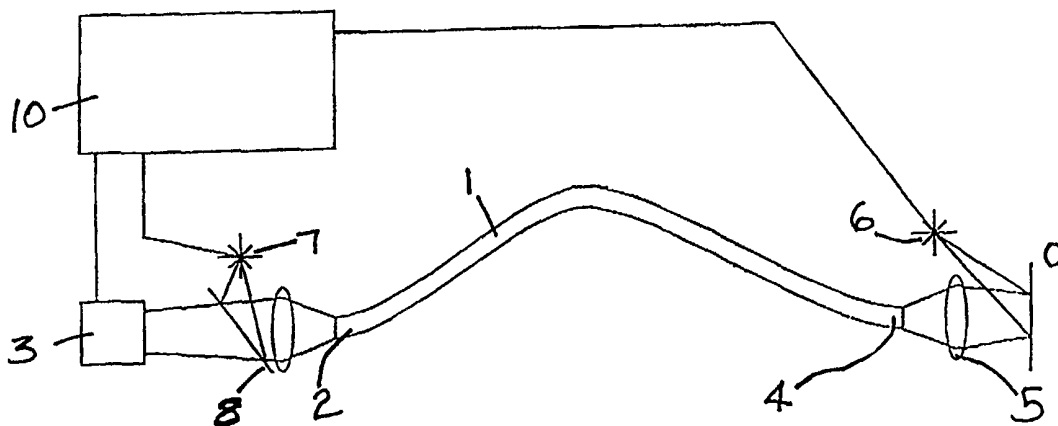

INTERNATIONAL APPLICATION PUBLISHED UNDER THE PATENT COOPERATION TREATY (PCT)

(51) International Patent Classification ⁶ : A61B 1/04	A1	(11) International Publication Number: WO 99/52416 (43) International Publication Date: 21 October 1999 (21.10.99)
<p>(21) International Application Number: PCT/GB99/01088</p> <p>(22) International Filing Date: 9 April 1999 (09.04.99)</p> <p>(30) Priority Data: 9807832.2 9 April 1998 (09.04.98) GB</p> <p>(71) Applicant (for all designated States except US): ISIS INNOVATION LIMITED [GB/GB]; 2 South Parks Road, Oxford, Oxfordshire OX1 3UB (GB).</p> <p>(72) Inventors; and (75) Inventors/Applicants (for US only): JUSTKAITIS, Rimvydas [LT/GB]; 3 Marriott Close, Oxford, Oxfordshire OX2 8NT (GB). NEIL, Mark, Andrew, Aquilla [GB/GB]; 22 Poplar Road, Botley, Oxford, Oxfordshire OX2 9LB (GB). WILSON, Tony [GB/GB]; 18 Jeune Street, Oxford, Oxfordshire OX4 1BN (GB).</p> <p>(74) Agents: PERKINS, Sarah et al.; Stevens, Hewlett & Perkins, 1 Serjeants' Inn, Fleet Street, London, Greater London EC4Y 1NT (GB).</p>	<p>(81) Designated States: CA, JP, KR, US, European patent (AT, BE, CH, CY, DE, DK, ES, FI, FR, GB, GR, IE, IT, LU, MC, NL, PT, SE).</p> <p>Published <i>With international search report.</i> <i>Before the expiration of the time limit for amending the claims and to be republished in the event of the receipt of amendments.</i></p>	

(54) Title: IMAGING APPARATUS



(57) Abstract

The confocal imaging apparatus includes first and second light sources (6, 7) located at opposite ends of a fibre optic bundle (1). One end of the fibre optic bundle (4) is located adjacent the object to be imaged the opposite end of the fibre optic bundle (2) is located adjacent a camera (3) that records the images received from the fibre optic bundle (4). An analyser (10) is used to extract a confocal image from the image of the object produced using the illumination from the first light source (6) and the image of the object produced using illumination from the second light source (7). The imaging apparatus is particularly suited to endoscopy applications and is able to provide video rate confocal images.

FOR THE PURPOSES OF INFORMATION ONLY

Codes used to identify States party to the PCT on the front pages of pamphlets publishing international applications under the PCT.

AL	Albania	ES	Spain	LS	Lesotho	SI	Slovenia
AM	Armenia	FI	Finland	LT	Lithuania	SK	Slovakia
AT	Austria	FR	France	LU	Luxembourg	SN	Senegal
AU	Australia	GA	Gabon	LV	Latvia	SZ	Swaziland
AZ	Azerbaijan	GB	United Kingdom	MC	Monaco	TD	Chad
BA	Bosnia and Herzegovina	GE	Georgia	MD	Republic of Moldova	TG	Togo
BB	Barbados	GH	Ghana	MG	Madagascar	TJ	Tajikistan
BE	Belgium	GN	Guinea	MK	The former Yugoslav Republic of Macedonia	TM	Turkmenistan
BF	Burkina Faso	GR	Greece	ML	Mali	TR	Turkey
BG	Bulgaria	HU	Hungary	MN	Mongolia	TT	Trinidad and Tobago
BJ	Benin	IE	Ireland	MR	Mauritania	UA	Ukraine
BR	Brazil	IL	Israel	MW	Malawi	UG	Uganda
BY	Belarus	IS	Iceland	MX	Mexico	US	United States of America
CA	Canada	IT	Italy	NE	Niger	UZ	Uzbekistan
CF	Central African Republic	JP	Japan	NL	Netherlands	VN	Viet Nam
CG	Congo	KE	Kenya	NO	Norway	YU	Yugoslavia
CH	Switzerland	KG	Kyrgyzstan	NZ	New Zealand	ZW	Zimbabwe
CI	Côte d'Ivoire	KP	Democratic People's Republic of Korea	PL	Poland		
CM	Cameroon	KR	Republic of Korea	PT	Portugal		
CN	China	KZ	Kazakstan	RO	Romania		
CU	Cuba	LC	Saint Lucia	RU	Russian Federation		
CZ	Czech Republic	LI	Liechtenstein	SD	Sudan		
DE	Germany	LK	Sri Lanka	SE	Sweden		
DK	Denmark	LR	Liberia	SG	Singapore		
EE	Estonia						

IMAGING APPARATUS

The present invention relates to imaging apparatus and in particular to apparatus capable of providing optically sectioned images that may be overlaid to form a three dimensional image. The present invention is particularly suited, but not exclusively, to endoscopy applications employing a fibre optic bundle.

A conventional fibre optic endoscope consists of a fibre optic bundle that is inserted into a human or animal body to the object to be imaged. The end of the fibre optic bundle outside of the body is usually connected to a camera whereas the opposite end of the fibre optic bundle inside the body has a light source that illuminates the site of interest. Scattered light from the object is imaged onto the end of the fibre optic bundle and is guided along the bundle to the camera. The image received by the camera is a conventional image with no depth information other than that obtainable from a simple lens system. Hence, the conventional endoscope is unable to provide optically sectioned images that might be used to create three dimensional images of the object inside the body. Moreover, the light source is usually located inside the body adjacent the object because difficulties arise with back reflections from the end of the optical fibres when the light is transmitted to the site of interest along the fibre optic bundle from the outside.

The present invention seeks to provide an imaging system that is arranged to provide optically sectioned images using a bundle of small light conduits such as optical fibres.

The present invention provides imaging apparatus comprising a first light source; a bundle of light conduits along which light from the first light source passes; a second light source; a lens system for focussing light from the bundle of light conduits onto a specimen and for focussing light scattered from the specimen back to the bundle of light conduits; and an analyser for extracting an optically sectioned image of the specimen from first and second images of the specimen, the first image being of the

specimen illuminated by the first light source and the second image being of the specimen illuminated using the second light source.

Preferably, the bundle of light conduits is a fibre optic bundle.

In a first embodiment of the present invention the first light source is positioned at a first end of the fibre optic bundle and the second light source is positioned at the opposite second end of the fibre optic bundle near to the specimen. Ideally, a beam splitter is provided between the end of the fibre optic bundle and the lens system whereby light from the second light source is introduced into the path of light emerging from the fibre optic bundle.

In an alternative embodiment of the present invention the optical fibres of the bundle are encased in a cladding medium and light from the first light source is coupled to the cladding medium. A prism may be provided for coupling light from the first light source with the cladding medium. Alternatively, the cladding medium may include an integral grating for coupling light from the first light source with the cladding medium. With this embodiment the second light source may be located at either the first or the second end of the fibre optic bundle.

Preferably, the first and second light sources provide substantially identical illumination of the specimen.

In an alternative aspect the present invention provides an adapter for a microscope having a light source and lens system including an objective lens, the adapter comprising a bundle of light conduits along which light from the microscope passes and a second light source, the bundle of light conduits and the second light source being positioned between the microscope light source and the objective lens whereby optically sectioned images of a specimen are extracted from first and second images of the specimen, the first image being of the specimen illuminated by the adapter light source and the second image being of the specimen illuminated using the microscope light source.

An embodiment of the present invention will now be described by way of example with reference to the accompanying drawings, in which:

Figure 1 is a schematic diagram of imaging apparatus in accordance with the present invention;

Figure 2 is a schematic diagram of the illumination system of the imaging apparatus of Figure 1;

5 Figure 3 is a schematic diagram of alternative imaging apparatus in accordance with the present invention; and

Figure 4 is a schematic diagram of conversion apparatus for use with a conventional microscope.

The imaging apparatus shown in Figure 1 employs a bundle 1 of
10 optically guiding, high refractive index, cores or light conduits embedded in a lower refractive index cladding matrix surrounded by an outer light absorbing sleeve, such as a bundle of optical fibres. As long as the geometrical arrangement of the light conduits is preserved along the length of the bundle, then images received at one end of the bundle are
15 transmitted faithfully with minimal loss of information to the opposite end of the bundle. Light falling on the cladding matrix between the light conduits is not guided along the bundle and instead the light is attenuated through absorption by the outer sleeve. This attenuation of the light falling on the cladding matrix is used to maintain the contrast of the image received by
20 the camera at the opposite end of the fibre optic bundle.

In Figure 1 it may be seen that a first end 2 of the fibre optic bundle 1 is aligned with a camera 3 so that images transmitted by the bundle 1 may be recorded. At the opposite, second end 4 of the fibre optic bundle a lens system 5 is provided, only one objective lens is shown in Figure 1, and a
25 light source 6. In addition to the light source 6, a second light source 7 is provided adjacent the first end 2 of the fibre optic bundle. A beam splitter 8 such as a semi-silvered mirror is used to direct the light from the second light source 7 into the first end 2 of the fibre optic bundle 1 whilst still permitting the first end of the fibre optic bundle to be imaged by the camera
30 3.

As seen more clearly in Figure 2, a second beam splitter 9 such as a semi-silvered mirror is provided between the second end 4 of the fibre optic

bundle and the objective lens 5. The second beam splitter 9 ensures that the light from the first and second light sources 6, 7 follow similar paths through the objective lens to the site of interest and back to the second end of the fibre optic bundle 1.

5 The two light sources 6, 7 and the camera 8 are connected to a controller 10 that controls operation of the light sources and analyses the images recorded by the camera.

 With the imaging apparatus described above, images including optically sectioned properties are produced from which the optically
10 sectioned image can be extracted. When the fibre optic bundle is illuminated by the second light source and is focused (i.e. resolved) onto the object O by the objective lens 5, light scattered by the object O is imaged exactly back into the optical fibres at the second end 4 producing a bright image at the first end 2. On the other hand, when the object is out of
15 focus, then the scattered light is imaged substantially equally into the optical fibres and the cladding matrix. This in turn produces a dimmer image because the light in the cladding is absorbed by the sleeve. For a three dimensional object, parts of the object will be exactly in focus whereas other parts will not be in focus and that portion of the object which
20 is in focus will appear as a much brighter image at the first end 2 of the fibre optic bundle. In this way the image produced at the first end 2 of the fibre optic bundle is a composite image consisting of a conventional image (i.e. non-sectioning) in combination with a sectioned image.

 This composite image I_1 that is received by the camera 8 is then
25 analysed by the controller 10 to extract the sectioned image I_s from the composite image. To extract the sectioned image a purely conventional image I_2 is also required which is subtracted from the composite image I_1 leaving the sectioned image I_s remaining. The conventional image is obtained by first illuminating the object O using only the first light source 6
30 and recording the image produced before re-illuminating the object using only the second light source 7 to produce the composite image.

 To ensure reliable extraction of the sectioned image, it is important

that the illumination provided by the first light source 6 is substantially the same as the illumination provided by the second light source 7. The illumination provided by both light sources should be uniform across the field of view and should not have the core structure of the bundle present in the light incident on the object. It is for this reason that the arrangement of Figure 2 is preferred. Corrections for small differences in the intensities of the illumination patterns can be accommodated by employing normalisation factors N_1 and N_2 and computing $N_2|I_2 - N_1|I_1$.

By recording two images, one conventional image and one composite image, at different focal positions a three dimensional image of the object can be created. The changes in focal position can be achieved by moving the objective lens position or by employing a vari-focal lens system. As only two images are required for each focal position because the entire image is produced instantaneously, video rate imaging is easily achieved and scanning across the object is avoided.

Particularly in endoscopy applications, the presence of the first light source 6 adjacent the object may be undesirable as it increases the complexity and size at the end of the fibre optics bundle inserted into the body. Alternative imaging apparatus that overcomes this problem is shown in Figure 3. The first light source 6 is omitted and an alternative third light source 11 is provided coupled to the cladding of the fibre optics bundle. As shown in Figure 3 the light source may be coupled to the cladding using a prism 12. Alternative means of coupling the light source 11 to the cladding by destroying the internal reflections of the cladding are also envisaged such as a grating. With this arrangement the outer light absorbing sleeve is removed from the bundle between the coupling point and the second end 4 of the fibre optic bundle to avoid attenuation of the light in the cladding and to enable the light coupled to the cladding to travel along the bundle to the object O.

With this alternative apparatus the light coupled to the cladding is not injected into the optical fibres and instead forms an inverse image of that produced by the light source 6. For an object exactly in focus, light

from the cladding is focused onto the object in the same way as before and the light scattered from the object is focused back into the cladding. This light is then absorbed in the length of the fibre optic bundle between the coupling point and the first end 2 of the bundle where the absorbing sleeve
5 remains present. Alternatively, a suitable mask may be introduced at the first end so as to block any light propagating towards the camera from the cladding region whilst permitting light from the core regions of the bundle to pass. This produces a dark image at the first end 2 that is recorded by the camera 8. When the object is out of focus, some of the light from the
10 cladding will be scattered by the object and directed into the optical fibres which produces a brighter image for the camera at the first end 2 of the bundle. Thus, when the third light source 11 is used on its own a composite image I_3 is produced of a conventional image minus a sectioned image. As before the sectioned image can be extracted by computing $I_2 - I_3$
15 (or $N_2 I_2 - N_3 I_3$ where necessary). This imaging apparatus provides the additional advantage that the sectioned image is twice as bright as that produced by the apparatus of Figures 1 and 2.

A further alternative imaging apparatus employs the second and third light sources 7 and 11 only. This arrangement has the advantage that
20 the problems of light reflected from the faces of the fibre optic bundle, which occur when the first light source 6 is used, do not arise.

Whilst the above description has focused on endoscopy applications both medial and non-medical, for example internal inspection of machines, the imaging apparatus may be used in a wide variety of applications
25 employing conventional microscopes. Figure 4 shows how a conventional microscope may be adapted to incorporate this imaging apparatus. The microscope includes an eye piece 13, a tube lens 14, a beam splitter 15, an objective lens 16 and a light source 17. The microscope usually operates in reflective mode with the specimen 18 located beyond the objective lens
30 16. In order to adapt the microscope to produce optically sectioned images (i.e. a confocal microscope) an optical sectioning adapter 19 is added between the beam splitter 15 and the objective lens 16. The optical

sectioning adapter 19 consists of two lens systems 20, 21 which are positioned either end of a fibre optic bundle 22 or other bundle of small cross-section light conduits. Beyond the second of the two lens systems 21 a beam splitter 23 is provided in combination with a second light source 24. As with the imaging apparatus described with reference to Figures 1, 2 and 3, in passing through the fibre optic bundle the light from the first light source 17 acquires structure in cross-section for the bundle this enables a sectioned image to be formed for those portions of the object that are in focus in combination with a conventional image of those portions of the object that are out of focus. The light from the second light source 24 does not pass through the fibre optic bundle and so generates a purely conventional image. The subtraction of the two images provides an optically sectioned image of the object that can be built up to form a three dimensional image by adjustment of the conventional lenses 14, 16.

The imaging apparatus is particular suited to endoscopy applications, however, the range of applications is much greater than this and indeed the imaging apparatus may be employed in almost all circumstances where an optically sectioned image is required. The advantages of the imaging system are that no moving parts are required to produce an optically sectioned image. Also, non-laser as well as laser light sources can be used, for example for fluorescent imaging or a light emitting diode.

CLAIMS

1. Imaging apparatus comprising a first light source; a bundle of light
conduits along which light from the first light source passes; a second
5 light source; a lens system for focussing light from the bundle of light
conduits onto a specimen and for focussing light scattered from the
specimen back to the bundle of light conduits; and an analyser for
extracting an optically sectioned image of the specimen from first and
second images of the specimen, the first image being of the specimen
10 illuminated by the first light source and the second image being of the
specimen illuminated using the second light source.
2. Imaging apparatus as claimed in claim 1, wherein the bundle of light
conduits is a fibre optic bundle.
15
3. Imaging apparatus as claimed in claims 1 or 2, wherein the first light
source is positioned at a first end of the fibre optic bundle and the
second light source is positioned at the opposite second end of the fibre
optic bundle near to the specimen.
20
4. Imaging apparatus as claimed in claim 3, wherein a beam splitter is
provided between the end of the fibre optic bundle and the lens system
whereby light from the second light source is introduced into a path
parallel to light emerging from the fibre optic bundle.
25
5. Imaging apparatus as claimed in claims 1 or 2, wherein the optical
fibres of the bundle are encased in a cladding medium and light from
the first light source is coupled to the cladding medium.
- 30 6. Imaging apparatus as claimed in claim 5, wherein a prism is provided
for coupling light from the first light source with the cladding medium.

7. Imaging apparatus as claimed in claim 5, wherein the cladding medium includes an integral grating for coupling light from the first light source with the cladding medium.
- 5 8. Imaging apparatus as claimed in claim 7, wherein a mask is provided at the first end of the fibre optic bundle for absorbing light propagating through the cladding medium.
9. Imaging apparatus as claimed in claims 5 to 8, wherein the first light
10 source is located at the second end of the fibre optic bundle.
10. Imaging apparatus as claimed in claims 5 to 8, wherein the first light source is located at the first end of the fibre optic bundle.
- 15 11. Imaging apparatus as claimed in any one of the preceding claims, wherein the first and second light sources are lasers.
12. Imaging apparatus as claimed in any one of the preceding claims, wherein the first and second light sources provide substantially identical
20 illumination of the specimen.
13. Imaging apparatus as claimed in any one of the preceding claims, wherein there is provided an analyser for extracting the optically sectioned image from the first and second images.
25
14. Imaging apparatus as claimed in claim 13, wherein the focal position of the lens system is adjustable and the analyser is adapted to produce a three dimensional images from a series of first and second images at different focal position.
30
15. An adapter for a microscope having a light source and lens system including an objective lens, the adapter comprising a bundle of light

conduits along which light from the microscope passes and a second light source, the bundle of light conduits and the second light source being positioned between the microscope light source and the objective lens whereby optically sectioned images of a specimen are extracted from first and second images of the specimen, the first image being of the specimen illuminated by the adapter light source and the second image being of the specimen illuminated using only the microscope light source.

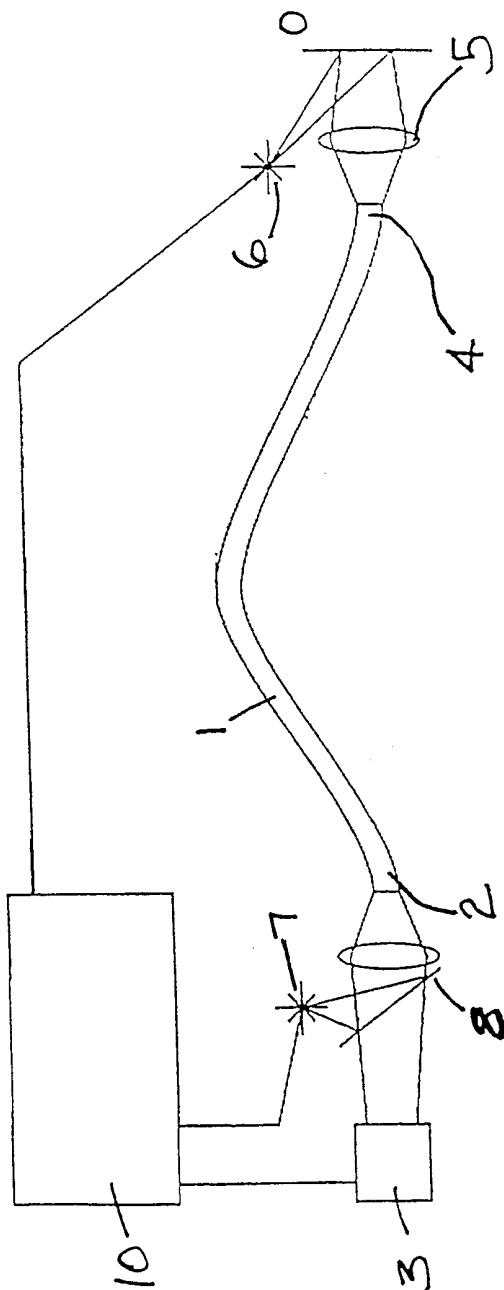

Figure 1

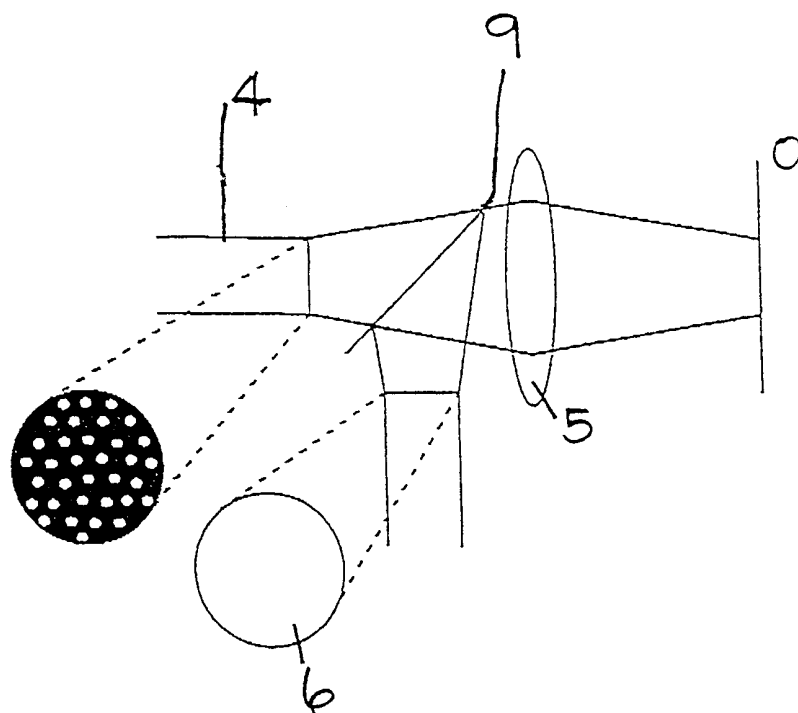

Figure 2

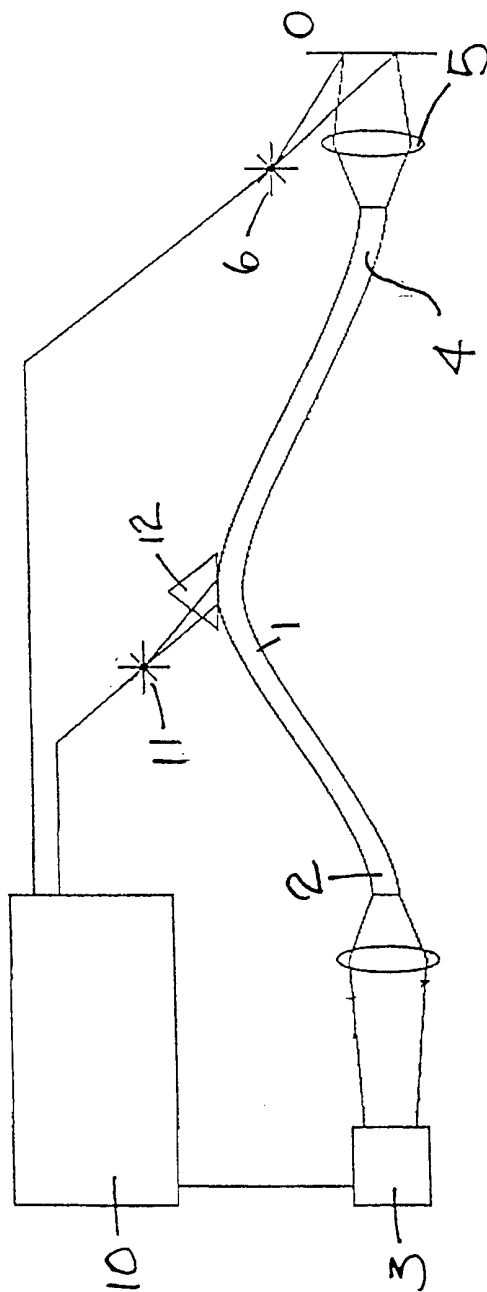

Figure 3

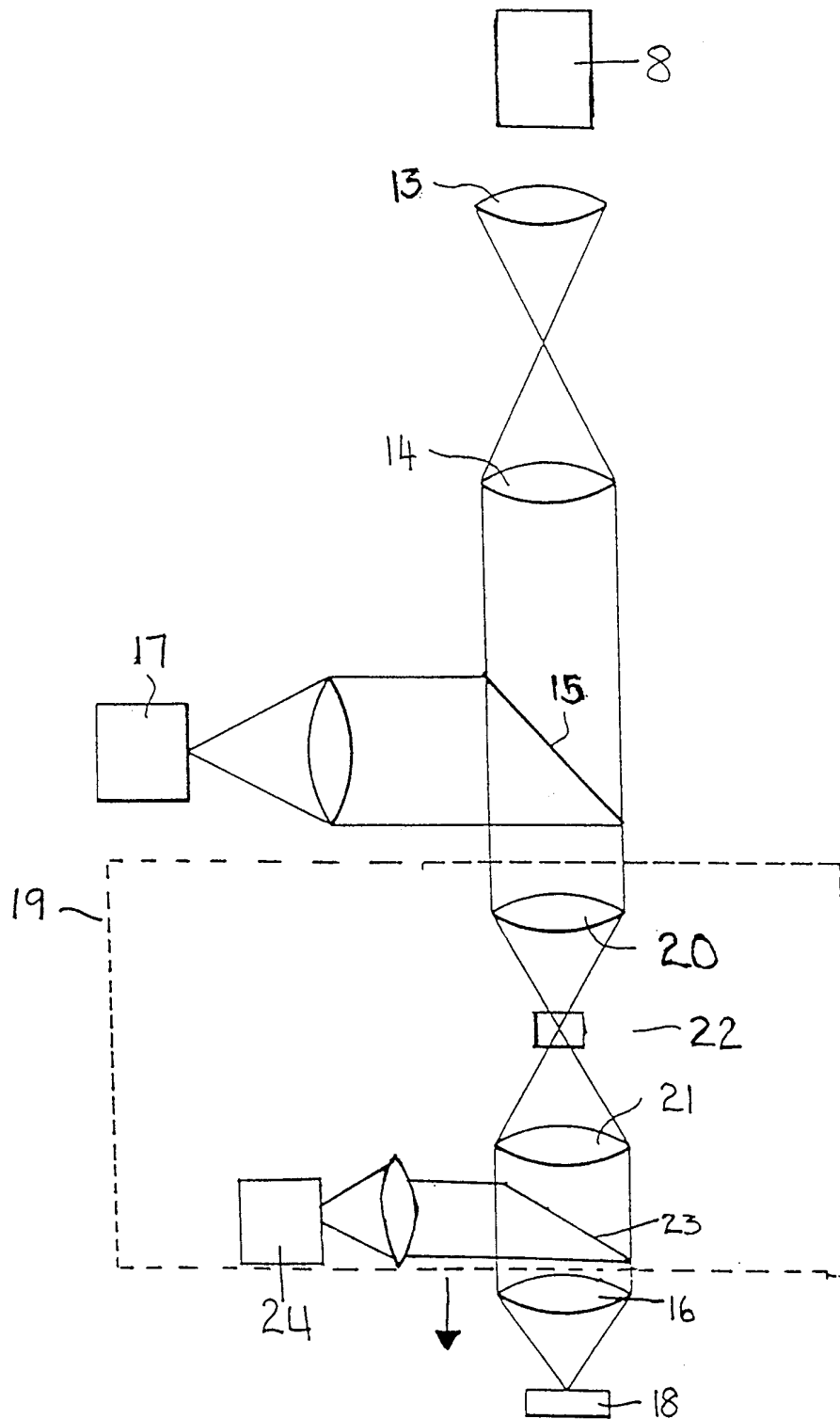

Figure 4

INTERNATIONAL SEARCH REPORT

International Application No

PCT/GB 99/01088

A. CLASSIFICATION OF SUBJECT MATTER

IPC 6 A61B1/04

According to International Patent Classification (IPC) or to both national classification and IPC

B. FIELDS SEARCHED

Minimum documentation searched (classification system followed by classification symbols)

IPC 6 A61B G02B

Documentation searched other than minimum documentation to the extent that such documents are included in the fields searched

Electronic data base consulted during the international search (name of data base and, where practical, search terms used)

C. DOCUMENTS CONSIDERED TO BE RELEVANT

Category	Citation of document, with indication, where appropriate, of the relevant passages	Relevant to claim No.
X	DE 38 18 104 A (OLYMPUS) 8 December 1988 (1988-12-08) column 8, line 68 - column 10, line 1 column 15, line 60 - column 16, line 27 column 20, line 46 - column 21, line 31	1, 2, 12, 13
Y	---	15
Y	WO 97 31282 A (ISIS) 28 August 1997 (1997-08-28) page 9, line 22 - page 10, line 7	15
X	DE 195 32 095 C (VOLKER) 8 August 1996 (1996-08-08) column 6, line 2 - column 10, line 12 ---	1, 2, 12
	-/--	

Further documents are listed in the continuation of box C.

Patent family members are listed in annex.

Special categories of cited documents :

"A" document defining the general state of the art which is not considered to be of particular relevance

"E" earlier document but published on or after the international filing date

"L" document which may throw doubts on priority claim(s) or which is cited to establish the publication date of another citation or other special reason (as specified)

"O" document referring to an oral disclosure, use, exhibition or other means

"P" document published prior to the international filing date but later than the priority date claimed

"T" later document published after the international filing date or priority date and not in conflict with the application but cited to understand the principle or theory underlying the invention

"X" document of particular relevance; the claimed invention cannot be considered novel or cannot be considered to involve an inventive step when the document is taken alone

"Y" document of particular relevance; the claimed invention cannot be considered to involve an inventive step when the document is combined with one or more other such documents, such combination being obvious to a person skilled in the art.

"&" document member of the same patent family

Date of the actual completion of the international search

30 July 1999

Date of mailing of the international search report

27/08/1999

Name and mailing address of the ISA

European Patent Office, P.B. 5818 Patentlaan 2
NL - 2280 HV Rijswijk
Tel. (+31-70) 340-2040, Tx. 31 651 epo nl,
Fax: (+31-70) 340-3016

Authorized officer

Lemercier, D

1

INTERNATIONAL SEARCH REPORT

International Application No

PCT/GB 99/01088

C.(Continuation) DOCUMENTS CONSIDERED TO BE RELEVANT		
Category	Citation of document, with indication, where appropriate, of the relevant passages	Relevant to claim No.
A	US 5 166 787 A (STORZ) 24 November 1992 (1992-11-24) column 6, line 34 - line 45 column 7, line 60 - column 8, line 43 column 9, line 64 - column 10, line 8 -----	1,3,9-12

INTERNATIONAL SEARCH REPORT

Information on patent family members

International Application No

PCT/GB 99/01088

Patent document cited in search report	Publication date	Patent family member(s)	Publication date
DE 3818104 A	08-12-1988	JP 63294509 A US 4862873 A	01-12-1988 05-09-1989
WO 9731282 A	28-08-1997	AU 1885997 A EP 0882247 A	10-09-1997 09-12-1998
DE 19532095 C	08-08-1996	NONE	
US 5166787 A	24-11-1992	DE 3921233 A AT 120628 T WO 9100049 A DE 59008855 D EP 0434793 A JP 4500768 T	14-02-1991 15-04-1995 10-01-1991 11-05-1995 03-07-1991 13-02-1992