

(19)



(11)

EP 3 748 272 B1

(12)

EUROPEAN PATENT SPECIFICATION

(45) Date of publication and mention of the grant of the patent:
17.08.2022 Bulletin 2022/33

(51) International Patent Classification (IPC):
F28D 7/16 ^(2006.01) **F25B 39/02** ^(2006.01)
F28D 3/04 ^(2006.01) **F28F 9/22** ^(2006.01)

(21) Application number: **20175901.6**

(52) Cooperative Patent Classification (CPC):
F28D 7/163; F25B 39/02; F28F 25/06;

(22) Date of filing: **21.05.2020**

F25B 2339/022; F28D 2021/0071; F28F 2009/224

(54) A HYBRID TUBE BUNDLE EVAPORATOR

HYBRIDROHRBÜNDELVERDAMPFER

ÉVAPORATEUR DE FAISCEAU DE TUBES HYBRIDE

(84) Designated Contracting States:
**AL AT BE BG CH CY CZ DE DK EE ES FI FR GB
GR HR HU IE IS IT LI LT LU LV MC MK MT NL NO
PL PT RO RS SE SI SK SM TR**

(72) Inventors:
• **COVOLO, Mariano**
36064 Mason Vicentino (Vicenza) (IT)
• **RUARO, Giacomo**
32032 Feltre (Belluno) (IT)

(30) Priority: **05.06.2019 IT 201900008154**

(74) Representative: **Rapisardi, Mariacristina**
Ufficio Brevetti Rapisardi S.r.l.
Via Serbelloni, 12
20122 Milano (IT)

(43) Date of publication of application:
09.12.2020 Bulletin 2020/50

(73) Proprietor: **Mitsubishi Electric Hydronics & IT Cooling Systems S.p.A.**
36061 Bassano del Grappa (Vicenza) (IT)

(56) References cited:
WO-A2-2011/011421 US-A- 2 384 413
US-A1- 2010 276 130 US-A1- 2011 120 181

EP 3 748 272 B1

Note: Within nine months of the publication of the mention of the grant of the European patent in the European Patent Bulletin, any person may give notice to the European Patent Office of opposition to that patent, in accordance with the Implementing Regulations. Notice of opposition shall not be deemed to have been filed until the opposition fee has been paid. (Art. 99(1) European Patent Convention).

Description

[0001] The present invention refers to an improved hybrid tube bundle evaporator having a low-load and high performance for vapour compression refrigeration circuits.

[0002] For some time the market has offered tube bundle and shell evaporators for known-type vapour compression refrigeration circuits, constituted substantially by a tube bundle inside a recipient usually having a cylindrical shape with a horizontal axis, usually known as a "shell", and closed at the ends.

[0003] The device is crossed by two fluid currents: a current corresponding to the process fluid, i.e. the fluid that is to be cooled, which flows on the "tube-side", that is, inside the tubes, while the other current corresponds to the service fluid, i.e. the refrigerant fluid used as the vector of the heat exchange and which flows on the "shell-side", i.e. in the space delimited between the inner surface of the shell and the outer surfaces of the tubes; the large outer surfaces of the tubes, generally having a modest diameter and in a large number, enable heat exchange of large quantities of heat.

[0004] The pathway of the tube bundle inside the shell can be straight, with a parallel axis to the longitudinal axis of the evaporator, from an inlet head to the opposite outlet head, or can be straight but with an outward and return pathway over the whole length of the shell, with an inlet and outlet at the same evaporator head; the type depends on the general characteristics of the system and the design choices and expected performances.

[0005] In extreme and simplistic synthesis, the process that takes place inside an evaporator in a refrigeration circuit is a continuous process, through which the flow of the service refrigerant fluid at a lower temperature subtracts heat from the process fluid flow at a higher temperature, and in turn heats up and changes from the liquid phase to the gaseous phase.

[0006] In the literature and on the market at least four types of tube bundle evaporators are well-known: the flooded type, i.e. with the tube bundle completely immersed in the service fluid in the moist phase; the low-load flooded type, in which the service fluid load is reduced coherently with the setting and control of other parameters of the system; the falling film type, in which the tubes are sprinkled by the service refrigerant fluid which falls in cascade; the spray type, where the service refrigerant fluid is sprayed onto the tubes.

[0007] Another type, known as hybrid, pairs the characteristics of the low-load flooded type with those of the falling film type.

[0008] WO 2011/011421 A2 discloses a horizontal tube bundle evaporator according to the preamble of claim 1.

[0009] As is known, each of these types has advantages and drawbacks: it is also known that exchangers at present in use require a considerable load of refrigerant fluid to improve the heat exchange, and adopt mechan-

ical solutions that constrain the arrangement of the inlet and outlet fittings of the refrigerant fluid, which must necessarily be arranged respectively on the bottom and on the top of the shell. These traditional arrangements of the fittings lead to significant evaporator volumes and constraints with the other components of the system, often relevant.

[0010] It is also known that all tube bundle evaporators have a service flow distribution in the shell that is not uniform, which can lead to a worsening of the evaporator performance.

[0011] To reduce the effect of the non-uniform flow distribution, generally partial partitions are installed, in a perpendicular direction to that of the flow, which switch the direction and make the velocity profile more uniform.

[0012] These configurations are notoriously poorly efficient, as the control and intervention conditions during routine operation of the system are especially delicate.

[0013] There therefore exists a need to simplify the structure of tube bundle evaporators for known-type vapour compression refrigeration circuits.

[0014] The technical task of the present invention is, therefore, to provide a horizontal tube bundle evaporator which obviates the above-described technical drawbacks of the prior art.

[0015] Within the context of this technical task, an object of the invention is to realise a tube bundle evaporator of a hybrid type, which unites the characteristics of the low-load flooded type and of the falling film type, thus obviating the drawbacks of both.

[0016] A further aim of the invention is to realise a tube bundle evaporator of a hybrid type which optimises the fluid-dynamics of the service fluid and the heat exchange with the process flow.

[0017] A further aim of the invention is to realise a tube bundle evaporator of a hybrid type from which the service fluid in outlet can be returned to the refrigeration circuit prevalently in the gaseous phase.

[0018] A further aim of the invention is to realise a tube bundle evaporator of a hybrid type which improves the distribution system of the service fluid on the tube bundle.

[0019] A further aim of the invention is to realise a tube bundle evaporator of a hybrid type which optimises the positions of the fittings towards the external devices.

[0020] The technical task, together with these and other objects according to the present invention, are attained by realising a horizontal tube bundle evaporator according to claim 1. Preferred embodiments are given in the dependent claims.

[0021] According to the invention, said conveying circuit comprises a descending portion of circuit delimited by at least one separating primary vertical partition separating a first upper chamber of said evaporator where the second number of tubes is positioned from a second upper lateral chamber of said evaporator where said outlet from the shell is positioned.

[0022] In an embodiment of the invention said separating primary vertical partition superiorly separates said

first upper chamber and said second upper lateral chamber and extends downwards up to a distance from the free surface of said flooded lower zone for collecting the refrigerant fluid in the liquid state.

[0023] In an embodiment of the invention said separating primary vertical partition delimits in cooperation with the free surface of said lower zone a connecting passage between said first upper chamber where said descending portion of circuit extends and said second upper lateral chamber where a rising portion of circuit extends in succession to said descending portion of circuit.

[0024] According to the invention said second upper lateral chamber contains a third number of tubes of said tube bundle arranged outside said lower zone, said outlet being positioned in said second upper lateral chamber above said third number of tubes.

[0025] Further characteristics and advantages of the invention will more fully emerge from the description of a preferred but not exclusive embodiment of the hybrid tube bundle evaporator according to the invention, illustrated by way of nonlimiting example in the appended drawings, wherein:

figure 1 shows an external view of the evaporator;
 figure 2 shows a perspective exploded view of the evaporator;
 figure 3 shows a cross-section of the evaporator perpendicular to the longitudinal axis;
 figure 4 shows a perspective upper view of the refrigerant fluid distributor;
 figure 5 shows a partial lower view of a detail of the refrigerant fluid distributor;
 figure 6 shows a partial perspective view of the assembly of internal components of the evaporator;
 figure 7 shows a partial perspective view of internal components of the evaporator;
 figure 8 shows a sectioned partial perspective view of the head with the inlet and outlet of the process fluid.

[0026] With reference to the figures mentioned, a horizontal axis hybrid tube bundle evaporator is denoted in its entirety by reference number 1, essentially constituted by a cylindrical shell 2, by two closing heads 3A and 3B, a tube bundle 4 thus identified in its entirety and contained inside the shell 2 where the tubes individually perform an outward and return pathway parallel to the longitudinal horizontal axis and over the whole length of the shell 2, an inlet 5 in a closing head 3A of the process fluid to be cooled and an outlet 6 in a closing head 3A of the cooled process fluid; the evaporator 1 further has two inlets 7A and 7B of the service refrigerant fluid in the liquid state in a lower lateral zone of the shell 2, symmetrically arranged in the direction of the longitudinal axis with respect to an outlet 8 of the service refrigerant fluid in the gaseous state positioned in an upper lateral zone of the shell 2, and an optical viewer 9 for controlling the level of the

service refrigerant fluid on the lower lateral wall of the shell 2.

[0027] The outlet 8 comprises a through-opening 8A through the thickness of the shell 2, entirely positioned below the upper end of the shell 2 and a fitting tube 8B which prolongs from the through-opening 8A to outside the shell 2 and projects for a terminal portion of the length thereof above the lateral border of the shell 2.

[0028] In practice only a terminal portion of the fitting tube 8B projects above the horizontal plane tangential to the upper end of the shell 2.

[0029] The fitting tube 8B is angular to connect correctly to the piping of the refrigeration circuit.

[0030] Each inlet 7A, 7B of the service refrigerant fluid in the liquid state comprises a through-opening 7'A, 7'B through the thickness of the shell 2 from which a fitting tube 7"A, 7"B positioned outside the shell 2 but entirely contained inside the lateral border of the shell 2.

[0031] In practice each fitting tube 7"A, 7"B is contained between the horizontal plane tangential to the upper end of the shell 2 and the horizontal plane tangential to the lower end of the shell 2.

[0032] A first number of tubes 41 of the tube bundle 4 is positioned in a lower zone 21 of the evaporator 1 flooded by the service fluid, a second number of tubes 42 is positioned in an upper zone 22 of the evaporator 1 above the first number of tubes 41.

[0033] A distributor 70 of the service refrigerant fluid is positioned in the upper zone 22 of the evaporator 1 above the second number of tubes 42 of the tube bundle 4, and is constituted by two opposite collectors 71A and 71B respectively connected to the inlets 7A and 7B of the refrigerant fluid in the evaporator 1, and mounted with a perpendicular axis to the longitudinal axis of the evaporator 1 and of the tube bundle 4.

[0034] A plurality of straight distribution tubes 72i is perpendicularly connected to both collectors 71A and 71B, by means of respective fittings 73i at the ends thereof, with a longitudinal axis parallel to the axis of the evaporator 1 and the tube bundle 4.

[0035] The distribution tubes 72i inferiorly have a plurality of longitudinal dispensing openings 74i made using laser cutting in the wall of the tube, through which the refrigerated fluid in the liquid state sprinkles the second number of tubes 42 by force of gravity.

[0036] The tube bundle 4 is supported inside the shell 2 by a plurality of transversal support plates 80i perpendicular to the longitudinal axis of the tubes and the evaporator 1, appropriately perforated for guided and continuous passage of the single tubes and appropriately configured for mounting inside the evaporator 1. Perpendicularly to the plurality of the transversal support plates 80i, and therefore parallel to the longitudinal axis of the evaporator 1, a further plurality of vertical longitudinal secondary partitions 81i advantageously joint-fixed to the transversal support plates 80i longitudinally divides, into a plurality of sectors, the tubes of the second number of tubes 42 of the tube bundle 4 in the zone 22 of the evaporator

1. The transversal support plates 80i further divide the longitudinal sectors into sub-units.

[0037] The transversal support plates 80i and the longitudinal partitions 81i have appropriate pluralities of savings and through-openings, respectively 82i and 83i which have the function of equalising the pressure of the refrigerant fluid between these sectors and sub-units inside the evaporator 1.

[0038] A plurality of longitudinal deflecting fins 85i is further fixed on the longitudinal partitions 81i, again with the aim of equalising the flow distribution of the refrigerant fluid by force of gravity on the tubes of the second number of tubes 42.

[0039] Laterally of the tube bundle of the second number of tubes 42 is located a special primary vertical partition 88, longitudinally extended, conjoined at the top thereof to the internal lateral surface of the shell 2 and inferiorly extending downwards up to a suitable distance from the free surface of the flooded lower zone 21 for collecting the refrigerant fluid in the liquid state.

[0040] The primary vertical partition 88 divides the upper zone 22 of the evaporator in which it defines a first upper chamber 23 in which the second number of tubes 42 and the distributor 70 of the service refrigerant fluid are housed, and a second upper lateral chamber 24 of the evaporator 1, towards the side of the shell 2 where the inlets 7A and 7B are located, to which the distributor 70 and the outlet 8 of the refrigerant fluid in the gaseous state are connected.

[0041] A third number of tubes 43 connected via a collector 51 in the head 3A is housed inside the second upper lateral chamber 24 of the evaporator 1.

[0042] The head 3A has the inlet collector 51 connected to the inlet 5 of the process fluid in the evaporator 1, and an outlet collector 61 connected to the outlet 6 of the cooled process fluid; the inlet collector 51 supplies the first number of tubes 41, the third number of tubes 43 and the lower group of tubes of said second number of tubes 42; the outlet collector 61 is supplied by an upper group of tubes of said second number of tubes 42.

[0043] Above the lower zone 21 of the evaporator 1 flooded by service fluid, but in proximity thereof vertically at the second upper lateral chamber 24, there is an upper horizontal row of tubes 44 of said first number of tubes 41, positioned at a higher level than the upper horizontal row of the tubes facing and vertically at said first upper chamber 23.

[0044] The operation of the evaporator 1 according to the invention emerges clearly from the description and illustration and, in particular, is substantially as follows.

[0045] The process fluid to be cooled is introduced into the evaporator 1 through the inlet 5 in the head 3A, and thus in the inlet collector 51 from which it is distributed into the first number of tubes 41, the third number of tubes 43 and the lower group of tubes of the second number of tubes 42.

[0046] The process fluid to be cooled, coming from the system circulation and appropriately moved by move-

ment means outside the evaporator, travels through the tubes in a horizontal-axis outward and return pathway inside the evaporator 1 over the whole length of the shell 2.

5 **[0047]** The upper group of tubes of the second number of tubes 42 thus returns to the outlet collector 61 in the head 3A, from which the appropriately-cooled process fluid is collected and connected to the outlet 6 from the evaporator 1 and reinjected into the cooling system circulation of which the evaporator is a part.

10 **[0048]** The service refrigerant fluid in the liquid state, coming from other lines of the cooling system and appropriately moved by movement means outside the evaporator, is injected into the evaporator 1 symmetrically, given equal conditions of temperature and pressure, through the two inlets 7A and 7B positioned in a lower lateral zone of the shell 2 the inside of which corresponds to the second upper lateral chamber 24 of the evaporator 1.

20 **[0049]** The two opposite collectors 71A and 71B are respectively connected to the inlets 7A and 7B of the fluid distributor 70 of the service refrigerant fluid, via which collectors and via the successive plurality of fittings 73i derived therefrom, the refrigerant fluid reaches the plurality of distribution tubes 72i from opposite ends. The supply of the refrigerant fluid from the collectors 71A and 71B to the opposite ends of the plurality of distribution tubes 72i advantageously guarantees the homogeneity of the temperature and pressure conditions of the refrigerant fluid in each tube and inside each of the tubes of the plurality of distribution tubes 72i. The refrigerant fluid locates, in the plurality of distribution tubes 72i, the plurality of lower longitudinal dispensing openings 74i, through which the refrigerant fluid in the liquid state sprinkles the second number of tubes 42 by force of gravity.

30 **[0050]** The heat exchange by convection, between the refrigerant flow and the outer walls of the second number of tubes 42 inside which the process fluid flows at a higher temperature, causes, among other things, the raising of the temperature of the refrigerant fluid, and a partial passage thereof from the liquid phase to the mixed-gaseous phase ("mist") and to the gaseous phase.

40 **[0051]** The refrigerant fluid, in its fall by force of gravity from the plurality of lower longitudinal dispensing openings 74i in the plurality of distribution tubes 72i on the second number of tubes 42, is compartmentalised into a plurality of sub-units of a plurality of sectors defined by the plurality of transversal support plates 80i and of the vertical longitudinal partitions 81i.

50 **[0052]** The plurality of longitudinal deflecting fins 85i fixed on the longitudinal partitions 81i advantageously facilitates the detachment of the refrigerant fluid that might have accumulated on the longitudinal partitions 81i during the liquid phase and a better and progressive redistribution on the rows of the second number of tubes 42 positioned inferiorly of the longitudinal deflecting fins 85i.

[0053] The plurality of savings and through-openings,

respectively 82i and 83i in the transversal support plates 80i and in the longitudinal partitions 81i which are compartmentalised into a plurality of sub-units of a plurality of sectors inside the evaporator 1, advantageously facilitate the uniformity of the distribution of the refrigerant fluid during the progressively gaseous and mixed-gaseous phase in the progressive fall thereof on the rows of the second number of tubes 42.

[0054] The portion of refrigerant fluid still in the liquid phase, after having sprayed the second number of tubes 42 by force of gravity, precipitates and is collected in (floods) the lower zone 21 of the evaporator 1, where the first number of tubes 41 of the tube bundle 4 is positioned and where the heat exchange is actuated in a static form by conduction between the refrigerant fluid in the liquid phase and the outer walls of the first number of tubes 41 of the tube bundle 4 which remains completely immersed (flooded) in the fluid.

[0055] Using the optical viewer 9 positioned on the lateral lower wall of the shell 2, the level of the service refrigerant fluid in the flooded lower zone 21 is controlled, which level must be maintained, by an appropriate control and balancing of the functions of the system outside the evaporator 1, at a higher level than the upper horizontal row of the first number of tubes 41 of the tube bundle 4.

[0056] The portion of refrigerant fluid in the gaseous and mixed-gaseous phase, created for the heat exchange realised with interaction of the refrigerant fluid and the second number of tubes 42 in the first upper chamber 23 of the evaporator 1, physically and naturally tending to vertically rise towards the top of the first upper chamber 23, is advantageously aspirated by means of an appropriate depression created by aspirating means outside the evaporator 1 at the outlet 8 from the shell 2, positioned at the upper lateral chamber 24 of the evaporator 1.

[0057] The presence of the longitudinally-extended primary vertical partition 88 that defines the first upper chamber 23 and the second upper lateral chamber 24 of the evaporator 1, advantageously attributes to the portion of refrigerant fluid in the gaseous phase and mixed-gaseous phase a tortuous pathway from the first upper chamber 23 to the second upper lateral chamber 24 comprising at least one portion of a descending circuit.

[0058] The primary partition 88, in cooperation with the free surface of the collecting flooded lower zone 21, inferiorly delimits a connecting passage between the first upper chamber 23 where a descending portion of circuit extends, and the second upper lateral chamber 24 where a rising portion of circuit extends in succession to a descending portion of circuit of the tortuous pathway of the refrigerant fluid in the gaseous and mixed-gaseous phase.

[0059] In proximity of the connecting passage of the tortuous pathway, and superiorly of the flooded lower zone 21 of collection of a service fluid, but in proximity thereof and vertically at the second upper lateral chamber 24, there is the upper horizontal row of tubes 44 of the

first number of tubes 41, positioned at a higher level than the upper horizontal row of the tubes facing and vertically at said first upper chamber 23.

[0060] The tortuous pathway of the refrigerant fluid in gaseous and mixed-gaseous phase advantageously strikes, in the inversion from descending portion of circuit to rising portion of circuit, the upper horizontal row 44 of tubes of the first number of tubes 41 and thus actuates a heat exchange which tends to reduce the moisture still remaining in the mixed-gaseous phase.

[0061] The third number of tubes 43 is also housed inside the second upper lateral chamber 24 and is arranged at an upper level than the horizontal row of tubes 44, which is further struck by the refrigerant fluid in the gaseous and mixed-gaseous phase in a rising portion of circuit of the tortuous pathway, actuating a further heat exchange which tends to eliminate the moisture still residual in the mixed-gaseous phase (mist).

[0062] The refrigerated service fluid is advantageously thus distanced by the evaporator 1 from the outlet 8 and injected into the circuit of the refrigeration system in prevalently gaseous phase.

[0063] The horizontal evaporator of the invention is characterised in particular by the specific construction of the distributor 70.

[0064] Among the special aspects of the distributor 70, already evident from what has been described and illustrate in the foregoing, the distributor 70 has a tube distribution system 72i, with the tubes being provided with one or more lower longitudinal openings 74i.

[0065] The lower longitudinal openings 74i preferably extend longitudinally along the lower axial generatrix of the distribution tubes 72i.

[0066] The tubes 72i can be supplied at an end thereof by a single tubular collector or, as has been seen, they can be supplied at both ends by opposite tubular collectors 71, 71B.

[0067] The tubes 72i can have various shapes, dimensions and arrangements.

[0068] The tubes 72i are preferably straight, cylindrical, and are orientated horizontally in the longitudinal direction of the evaporator 1.

[0069] The tubes 72i do not necessarily need to be all positioned at the same height, in particular, to optimise the occupation of the space inside the shell 2, the arrangement of the tubes 72i can be adapted to the internal profile of the shell 2.

[0070] In particular, if the shell 2 is cylindrical, the distribution tubes 72i can be arranged following the internal profile of the shell 2, with the central tubes 72i higher and the lateral tubes 72i gradually lower.

[0071] The distribution tubes 72i can be all of identical transversal dimensions, inside diameter and external diameter in the case of the cylindrical shape.

[0072] It is also possible to modulate the entity of the flow of refrigerant liquid in free fall in a transversal direction to the longitudinal axis of the evaporator 1.

[0073] For example in some applications a more abun-

dant flow can be requested at the centre, so that the central tubes 72i can have an internal passage section that is greater than the passage section of the lateral tubes 72i and longitudinal openings 74i having a greater area than that of the lateral tubes 72i.

[0074] The distribution tubes 72i can be supported directly by the transversal support plates 80i.

[0075] The transversal support plates 80i can therefore have first support holes of the tube bundle 4 and, above the first holes, second support holes of the distribution tubes 72i.

[0076] The lower longitudinal dispensing openings 74i are preferably fashioned by laser cutting so as to have high dimensional precision.

[0077] The number, shape and dimension of the lower longitudinal dispensing openings 74i can vary.

[0078] In an embodiment there might only be one lower longitudinal dispensing opening 74i which extends along at least the majority of the length of the distribution tube 72i.

[0079] In an embodiment the lower longitudinal dispensing openings 74i are straight slots. In an embodiment the lower longitudinal dispensing openings 74i are slots having a constant width.

[0080] In an embodiment the lower longitudinal dispensing openings 74i are slots having a constant length.

[0081] In other embodiments, in the case of a distributor 70 with the two tubular collectors 71A and 71B, the lower longitudinal dispensing openings 74i are slots having, from the end of the distribution tubes 72i towards the centre of the distribution tubes 72i, a constant width and a progressively increasing length, or a constant length and a progressively increasing width, or a progressively increasing width and length, or an increasing width in the case of a single longitudinal dispensing opening 74i.

[0082] In other embodiments, in the case of a distributor 70 with the a single tubular collector, the lower longitudinal dispensing openings 74i are slots having, from the end of the distribution tubes 72i connected to the collector towards the free end of the distribution tubes 72i, a constant width and a progressively increasing length, or a constant length and a progressively increasing width, or a width and a length that are progressively increasing, or an increasing width in the case of a single longitudinal dispensing opening 74i.

[0083] Lastly, as demonstrated, the distribution tubes 71i can project below the lower axial generatrix of the tubular collectors 71A, 71B.

[0084] This is made possible by the angular fittings 73i connected to each collector 71A and 71B below the median longitudinal plane thereof.

[0085] Modifications and variants to the hybrid tube bundle evaporator described in the foregoing are possible provided they are within the scope of the appended claims.

[0086] It has in practice been observed that a hybrid tube bundle evaporator comprising a service refrigerant fluid distributor according to the invention is particularly

advantageous for optimising the service fluid distribution on the tube bundle.

5 Claims

1. A tube bundle evaporator (1) longitudinally extending along a horizontal axis, comprising a shell (2), a tube bundle (4) housed inside the shell, a shell-side refrigerant fluid, a tube-side refrigerated fluid, a lower zone (21) of said evaporator (1) flooded by the refrigerant fluid in the liquid state and containing a first number of tubes (41) of said tube bundle (4), a service refrigerant fluid distributor (70) positioned in an upper zone (22) of said evaporator (1) for dispensing the refrigerant fluid in the liquid state by free fall onto a second number of tubes (42) of the tube bundle (4) positioned outside said lower zone (21) above said first number of tubes (41), comprising at least one outlet (8) of refrigerant fluid in the gaseous state positioned in an upper lateral zone of the shell (2), and a conveying circuit being included inside the shell (2), for conveying refrigerant fluid in the gaseous state towards said at least one upper lateral outlet (8), said conveying circuit comprising a descending portion of circuit delimited by at least one separating primary vertical partition (88) longitudinally extended, conjoined at the top thereof to the internal lateral surface of said shell (2), separating a first upper chamber (23) of said evaporator where the second number of tubes (42) is positioned from a second upper lateral chamber (24) of said evaporator (1) where said outlet (8) from said shell is positioned, **characterised in that** said second upper lateral chamber (24) contains a third number of tubes (43) of said tube bundle (4) arranged outside said lower zone (21), said outlet (8) being positioned in said second upper lateral chamber (24) above said third number of tubes (43) .
2. The horizontal tube bundle evaporator (1) according to any one of the preceding claims, comprising at least one inlet (7A) of the service refrigerant fluid in the liquid state in a lateral zone of said shell (2).
3. The horizontal tube bundle evaporator (1) according to any one of the preceding claims, wherein said at least one outlet (8) comprises a through-opening (8A) through the thickness of said shell (2) entirely positioned below the upper end of said shell (2) and a fitting tube (8B) which prolongs from said through-opening (8A) to outside said shell (2) and projects by a terminal portion of the length thereof above the lateral border of said shell (2).
4. The horizontal tube bundle evaporator (1) according to the preceding claim, wherein said fitting tube (8B) is angular.

5. The horizontal tube bundle evaporator (1) according to any one of claims 2 to 4, wherein said at least one inlet (7A) of the service refrigerant fluid in the liquid state comprises a through-opening (7'A) through the thickness of said shell (2) from which a fitting tube (7"A) prolongs that is positioned outside said shell (2) but which is entirely contained inside the lateral border of said shell (2).
6. The horizontal tube bundle evaporator (1) according to any preceding claim, wherein said separating primary vertical partition (88) superiorly separates said first upper chamber (23) and said second upper lateral chamber (24) and extends downwards up to a distance from the free surface of said flooded lower zone (21) for collecting the refrigerant fluid in the liquid state.
7. The horizontal tube bundle evaporator (1) according to any preceding claim, wherein said separating primary vertical partition (88), in cooperation with the free surface of said lower zone (21), inferiorly delimits a connecting passage between said first upper chamber (23) where said descending portion of circuit extends and said second upper lateral chamber (24) where a rising portion of circuit extends in succession to said descending portion of circuit.
8. A vapour compression refrigeration circuit comprising a tube bundle evaporator according to any of the preceding claims.

Patentansprüche

1. Rohrbündelverdampfer (1), der sich längs entlang einer horizontalen Achse erstreckt, umfassend einen Mantel (2), ein Rohrbündel (4), das im Mantel untergebracht ist, ein mantelseitiges Kältemittel, ein rohrseitiges Kältemittel, eine untere Zone (21) des Verdampfers (1), die vom Kältemittel im flüssigen Zustand geflutet ist und eine erste Anzahl von Rohren (41) des Rohrbündels (4) enthält, einen Betriebskältemittelverteiler (70), der in einer oberen Zone (22) des Verdampfers (1) positioniert ist, um Kältemittel im flüssigen Zustand durch freien Fall auf eine zweite Anzahl von Rohren (42) des Rohrbündels (4), die außerhalb der unteren Zone (21) über der ersten Anzahl von Rohren (41) positioniert sind, auszugeben, umfassend mindestens einen Auslass (8) von Kältemittel im gasförmigen Zustand, der in einer oberen Seitenzone des Mantels (2) positioniert ist, und einen Förderkreislauf, der im Mantel (2) eingeschlossen ist, um Kältemittel im gasförmigen Zustand hinführend zum mindestens einen oberen Seitenauslass (8) zu befördern, wobei der Förderkreislauf mindestens einen absteigenden Kreislaufabschnitt umfasst, der durch mindestens eine vertikale

Haupttrennung (88) begrenzt ist, die sich längs erstreckt, die an ihrer Oberseite mit der inneren seitlichen Oberfläche des Mantels (2) zusammengefügt ist, trennend eine erste obere Kammer (23) des Verdampfers, in der die zweite Anzahl von Rohren (42) positioniert ist, von einer zweiten oberen Seitenkammer (24) des Verdampfers (1), in der der Auslass (8) aus dem Mantel positioniert ist, **dadurch gekennzeichnet, dass** die zweite obere Seitenkammer (24) eine dritte Anzahl von Rohren (43) des Rohrbündels (4) enthält, die außerhalb der unteren Zone (21) angeordnet sind, wobei der Auslass (8) in der zweiten oberen Seitenkammer (24) über der dritten Anzahl von Rohren (43) positioniert ist.

2. Horizontaler Rohrbündelverdampfer (1) nach einem der vorhergehenden Ansprüche, umfassend mindestens einen Einlass (7A) des Betriebskältemittels im flüssigen Zustand in einer Seitenzone des Mantels (2).
3. Horizontaler Rohrbündelverdampfer (1) nach einem der vorhergehenden Ansprüche, wobei der mindestens eine Auslass (8) eine Durchführungsöffnung (8A) durch die Dicke des Mantels (2) umfasst, die vollständig unter dem oberen Ende des Mantels (2) positioniert ist, und ein Rohrformstück (8B), das sich von der Durchführungsöffnung (8A) zur Außenseite des Mantels (2) ausdehnt und um einen Endabschnitt seiner Länge über der Seitenkante des Mantels (2) hervorsteht.
4. Horizontaler Rohrbündelverdampfer (1) nach dem vorhergehenden Anspruch, wobei das Rohrformstück (8B) winkelig ist.
5. Horizontaler Rohrbündelverdampfer (1) nach einem der Ansprüche 2 bis 4, wobei der mindestens eine Einlass (7A) des Betriebskältemittels im flüssigen Zustand eine Durchführungsöffnung (7'A) durch die Dicke des Mantels (2) umfasst, aus der sich ein Rohrformstück (7"A) ausdehnt, das außerhalb des Mantels (2) positioniert ist, das jedoch vollständig innerhalb der Seitenkante des Mantels (2) enthalten ist.
6. Horizontaler Rohrbündelverdampfer (1) nach einem der vorhergehenden Ansprüche, wobei die vertikale Haupttrennung (88) oberseitig die erste obere Kammer (23) und die zweite obere Seitenkammer (24) trennt und sich nach unten bis zu einem Abstand von der freien Oberfläche der gefluteten unteren Zone (21) erstreckt, um das Kältemittel im flüssigen Zustand zu sammeln.
7. Horizontaler Rohrbündelverdampfer (1) nach einem der vorhergehenden Ansprüche, wobei die vertikale Haupttrennung (88) in Kooperation mit der freien Oberfläche der unteren Zone (21) unterseitig

einen Verbindungsdurchgang zwischen der ersten oberen Kammer (23), in der sich der absteigende Kreislaufabschnitt erstreckt, und der zweiten oberen Seitenkammer (24), in der sich in Folge des absteigenden Kreislaufabschnitts ein aufsteigender Kreislaufabschnitt erstreckt, begrenzt.

8. Dampfkomppressionskältekreislauf, umfassend einen Rohrbündelverdampfer nach einem der vorhergehenden Ansprüche.

Revendications

1. Évaporateur de faisceau de tubes (1) s'étendant longitudinalement le long d'un axe horizontal, comprenant une coque (2), un faisceau de tubes (4) logé à l'intérieur de la coque, un fluide réfrigérant côté coque, un fluide réfrigéré côté tube, une zone inférieure (21) dudit évaporateur (1) inondée par le fluide réfrigérant à l'état liquide et contenant un premier nombre de tubes (41) dudit faisceau de tubes (4), un distributeur de fluide réfrigérant de service (70) positionné dans une zone supérieure (22) dudit évaporateur (1) pour distribuer le fluide réfrigérant à l'état liquide par chute libre sur un second nombre de tubes (42) du faisceau de tubes (4) positionné à l'extérieur de ladite zone inférieure (21) au-dessus dudit premier nombre de tubes (41), comprenant au moins une sortie (8) de fluide réfrigérant à l'état gazeux positionnée dans une zone latérale supérieure de la coque (2), et un circuit de transport étant inclus à l'intérieur de la coque (2), pour transporter le fluide réfrigérant à l'état gazeux vers ladite au moins une sortie latérale supérieure (8), ledit circuit de transport comprenant une portion descendante de circuit délimitée par au moins une cloison verticale primaire de séparation (88) étendue longitudinalement, jointe à son sommet à la surface latérale interne de ladite coque (2), en séparant une première chambre supérieure (23) dudit évaporateur où le deuxième nombre de tubes (42) est positionné à partir d'une deuxième chambre latérale supérieure (24) dudit évaporateur (1) où ladite sortie (8) de ladite coque est positionnée, **caractérisé en ce que** ladite deuxième chambre latérale supérieure (24) contient un troisième nombre de tubes (43) dudit faisceau de tubes (4) disposé à l'extérieur de ladite zone inférieure (21), ladite sortie (8) étant positionnée dans ladite deuxième chambre latérale supérieure (24) au-dessus dudit troisième nombre de tubes (43).
2. Évaporateur de faisceau de tubes horizontal (1) selon l'une quelconque des revendications précédentes, comprenant au moins une entrée (7A) du fluide réfrigérant de service à l'état liquide dans une zone latérale de ladite coque (2).

3. Évaporateur de faisceau de tubes horizontal (1) selon l'une quelconque des revendications précédentes, dans lequel ladite au moins une sortie (8) comprend une ouverture traversante (8A) à travers l'épaisseur de ladite coque (2) entièrement positionnée en dessous de l'extrémité supérieure de ladite coque (2) et un tube d'adaptation (8B) qui s'étend depuis ladite ouverture traversante (8A) jusqu'à l'extérieur de ladite coque (2) et fait saillie par une portion terminale de sa longueur au-dessus du bord latéral de ladite coque (2).
4. Évaporateur de faisceau de tubes horizontal (1) selon la revendication précédente, dans lequel ledit tube d'adaptation (8B) est angulaire.
5. Évaporateur de faisceau de tubes horizontal (1) selon l'une quelconque des revendications 2 à 4, dans lequel ladite au moins une entrée (7A) du fluide réfrigérant de service à l'état liquide comprend une ouverture traversante (7'A) à travers l'épaisseur de ladite coque (2) à partir de laquelle s'étend un tube d'adaptation (7''A) qui est positionné à l'extérieur de ladite coque (2) mais qui est entièrement contenu à l'intérieur du bord latéral de ladite coque (2).
6. Évaporateur de faisceau de tubes selon l'une quelconque des revendications précédentes, dans lequel ladite cloison verticale primaire de séparation (88) sépare supérieurement ladite première chambre supérieure (23) et ladite seconde chambre latérale supérieure (24) et s'étend vers le bas jusqu'à une distance de la surface libre de ladite zone inférieure inondée (21) pour recueillir le fluide réfrigérant à l'état liquide.
7. Évaporateur de faisceau de tubes horizontal (1) selon l'une quelconque des revendications précédentes, dans lequel ladite cloison verticale primaire de séparation (88), en coopération avec la surface libre de ladite zone inférieure (21), délimite inférieurement un passage de connexion entre ladite première chambre supérieure (23) où ladite portion descendante du circuit s'étend et ladite seconde chambre latérale supérieure (24) où une portion montante du circuit s'étend à la suite de ladite portion descendante du circuit.
8. Circuit frigorifique à compression de vapeur comprenant un évaporateur de faisceau de tubes selon l'une quelconque des revendications précédentes.

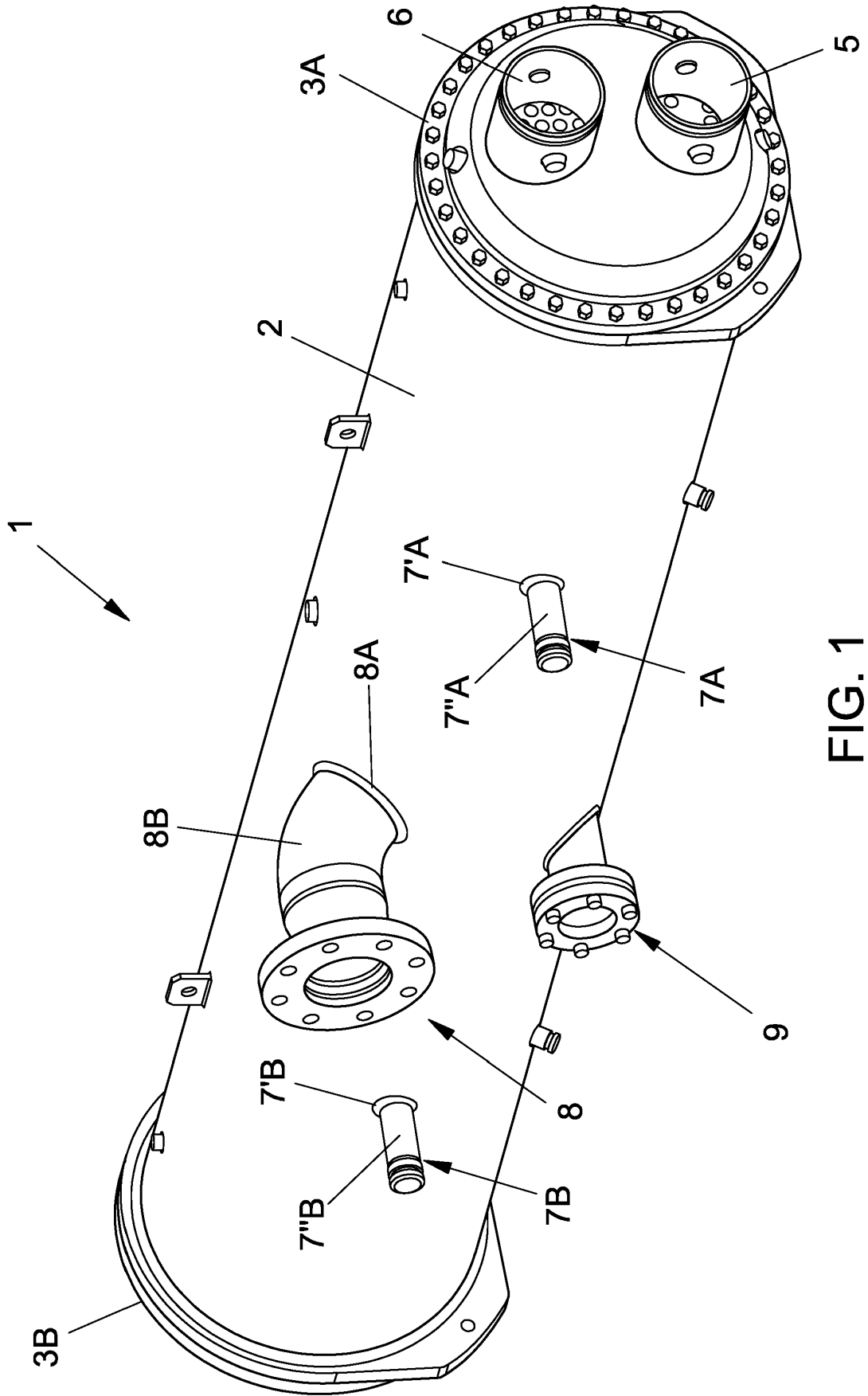

FIG. 1

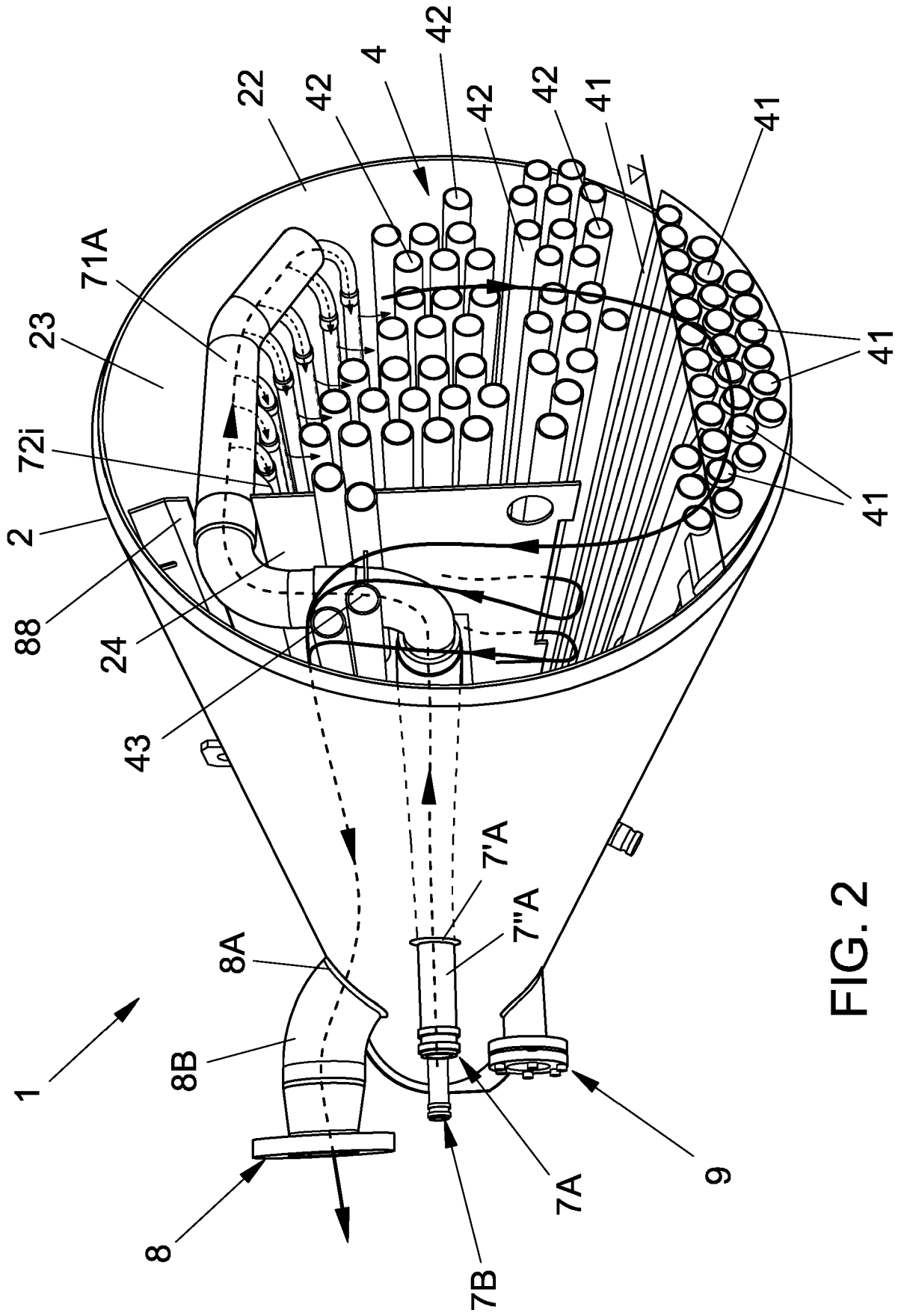

FIG. 2

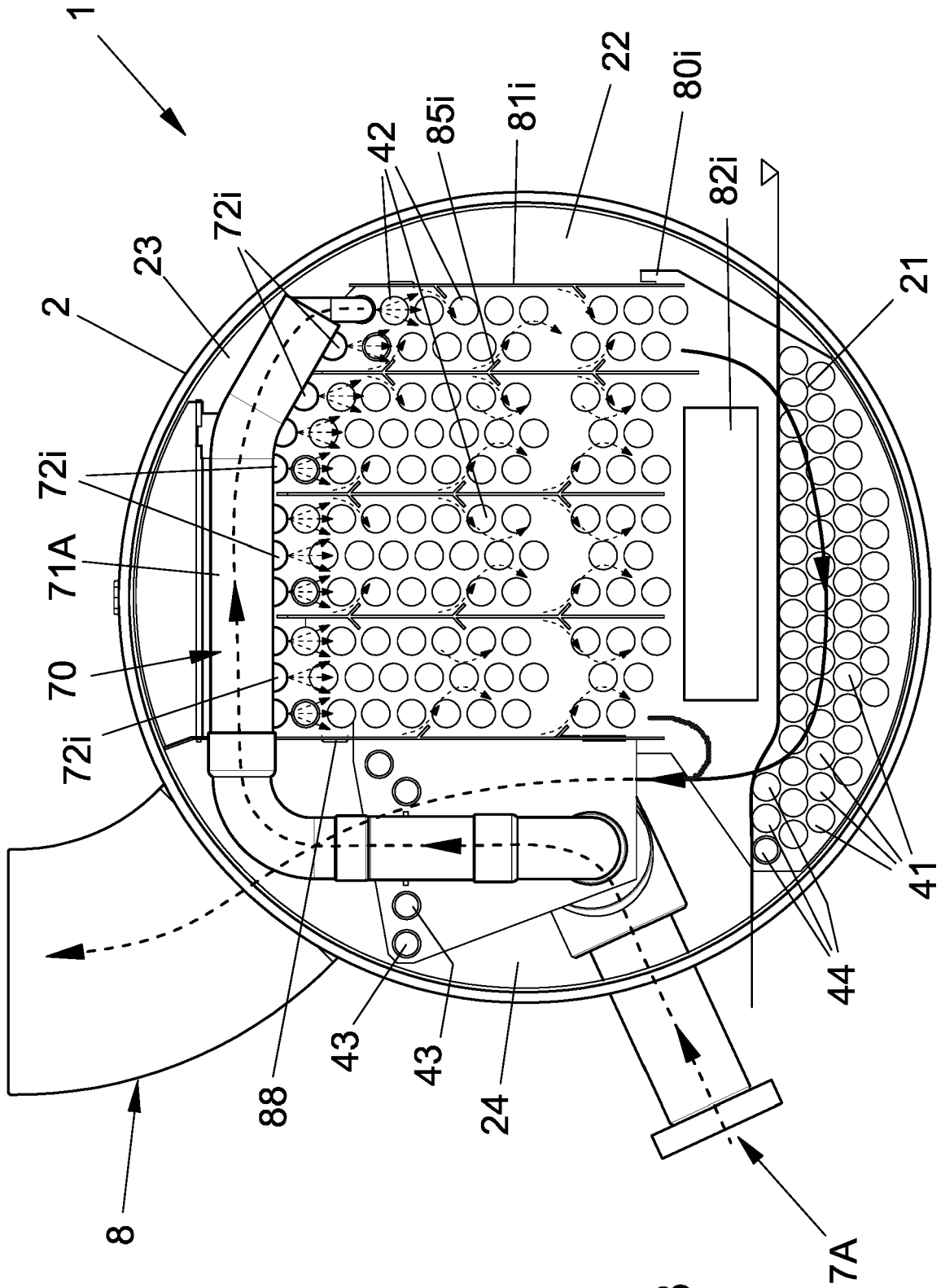

FIG. 3

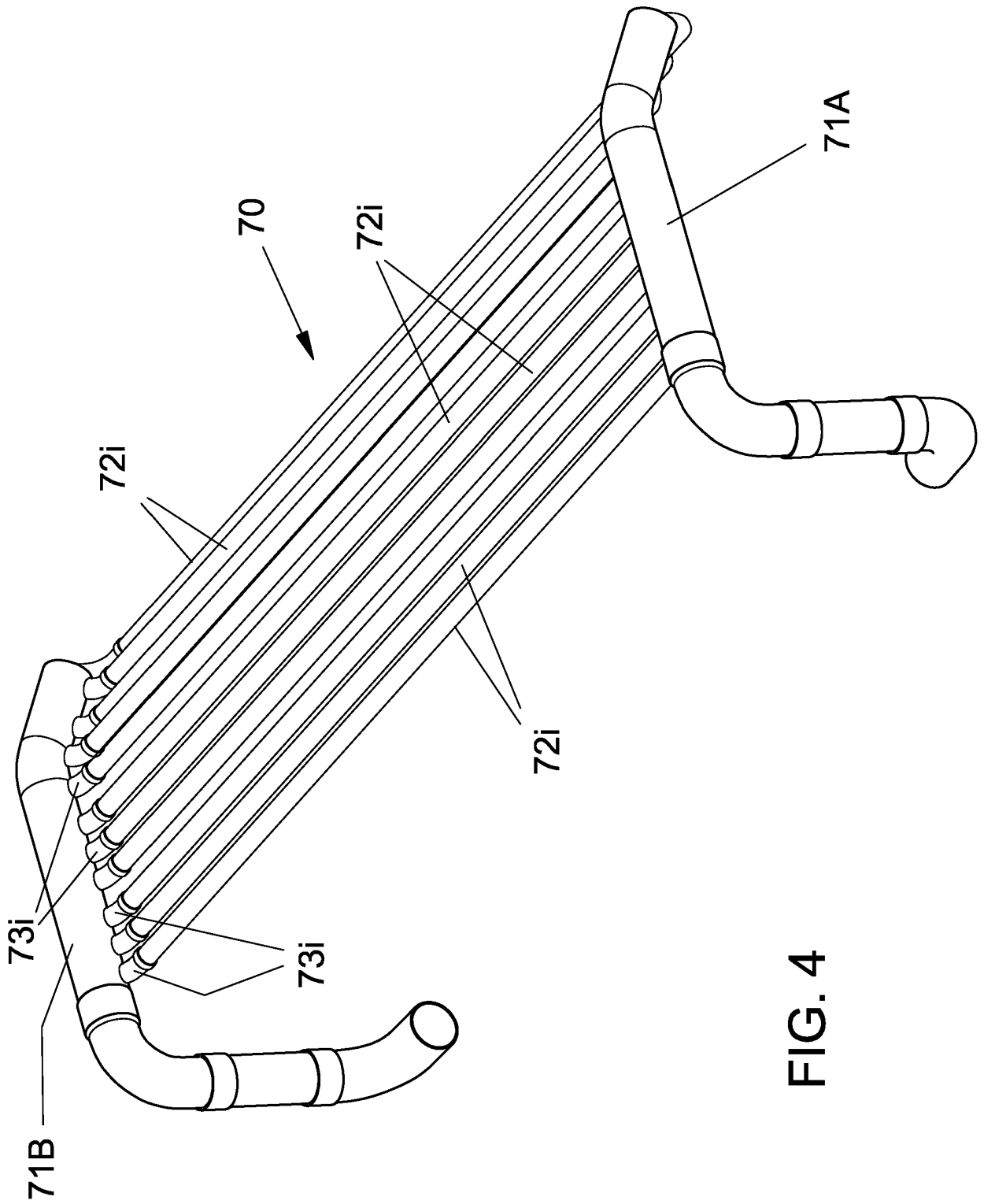

FIG. 4

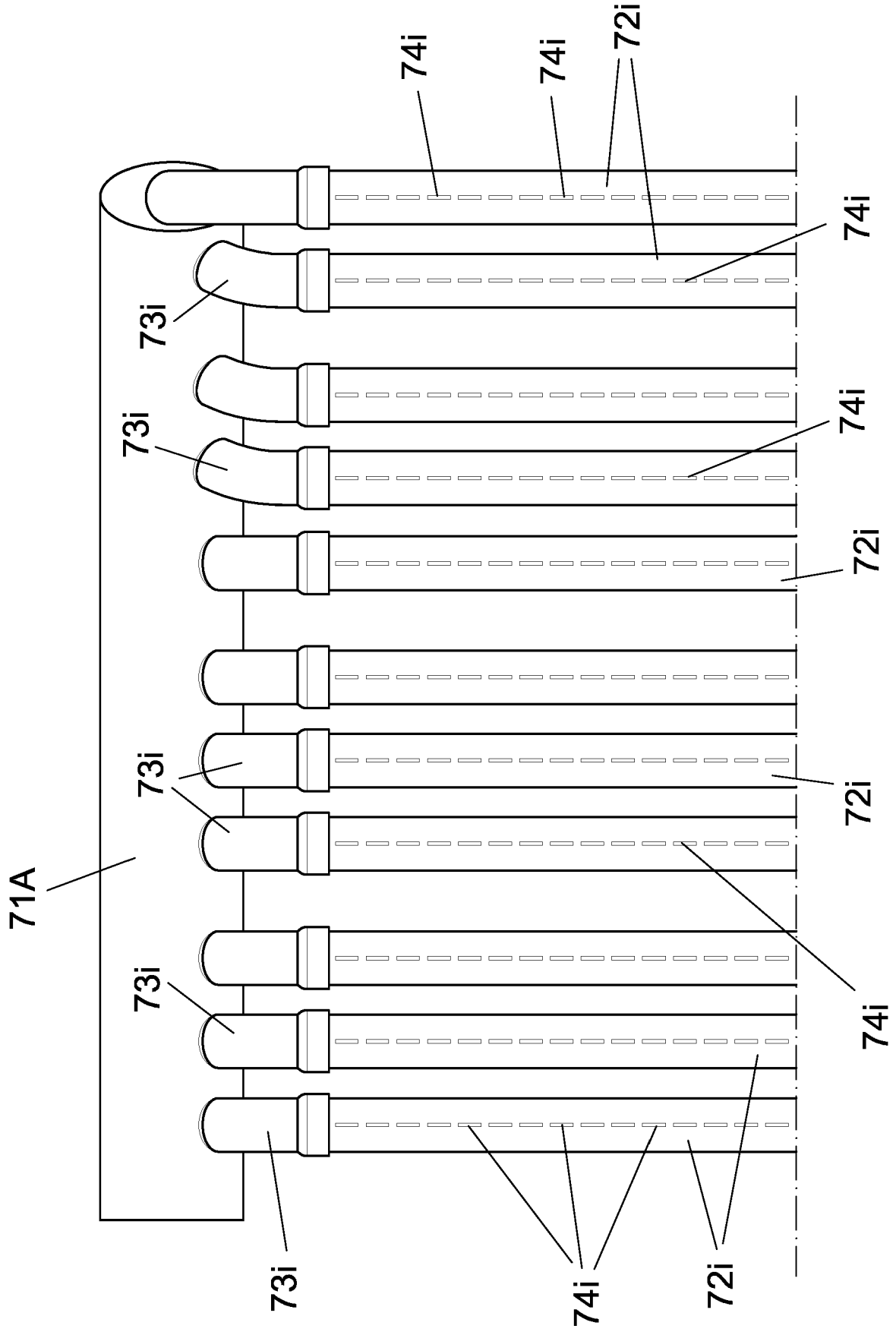

FIG. 5

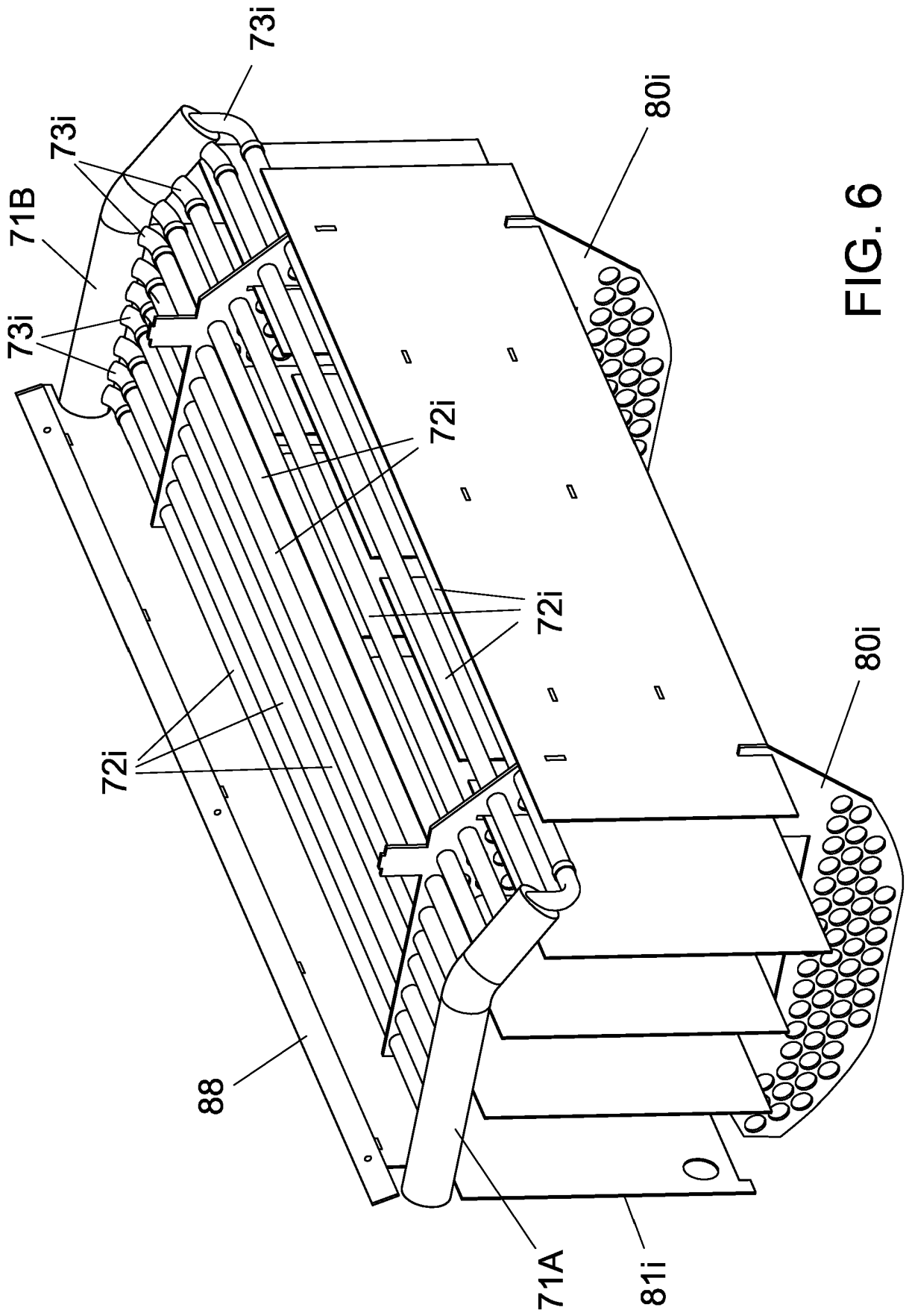

FIG. 6

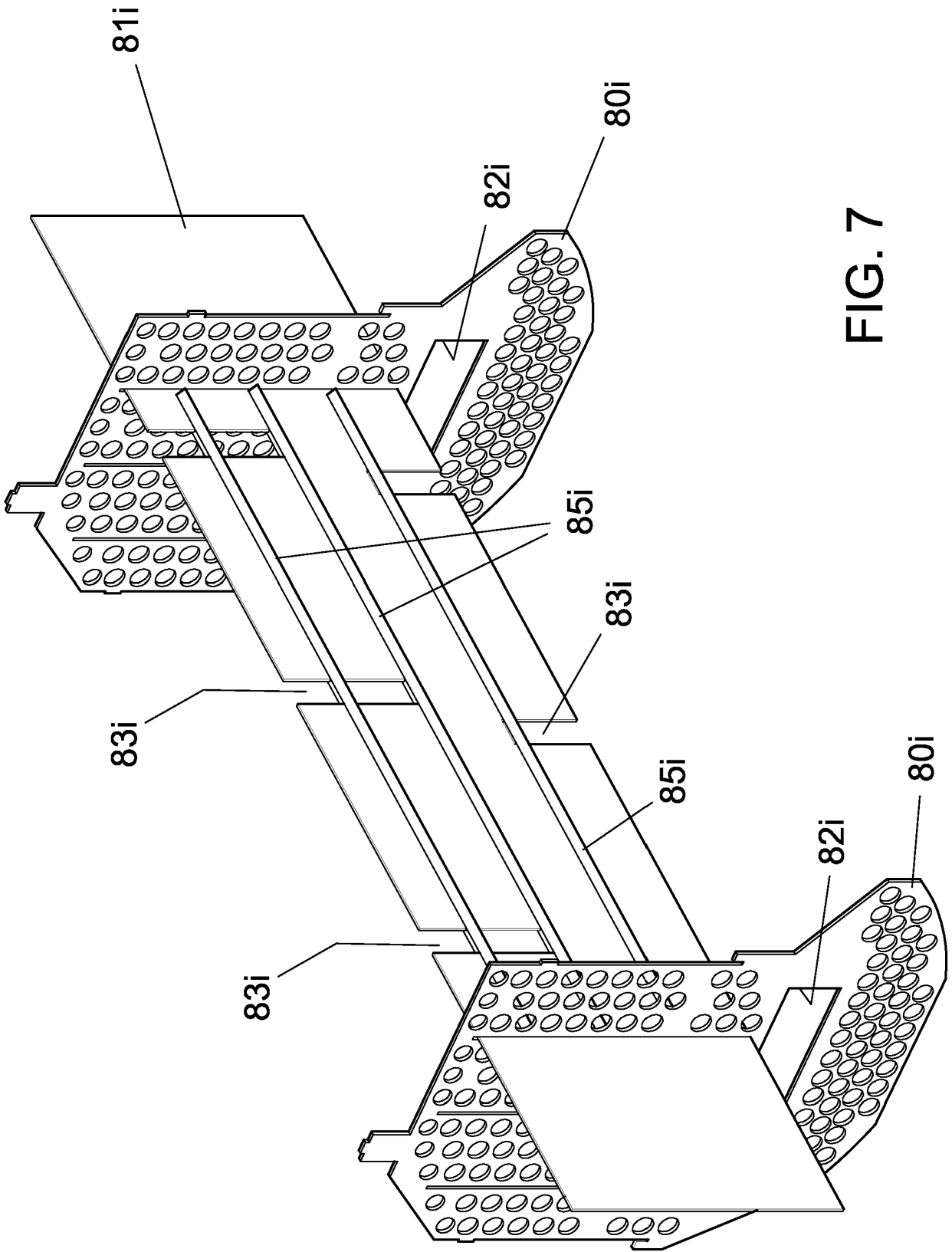

FIG. 7

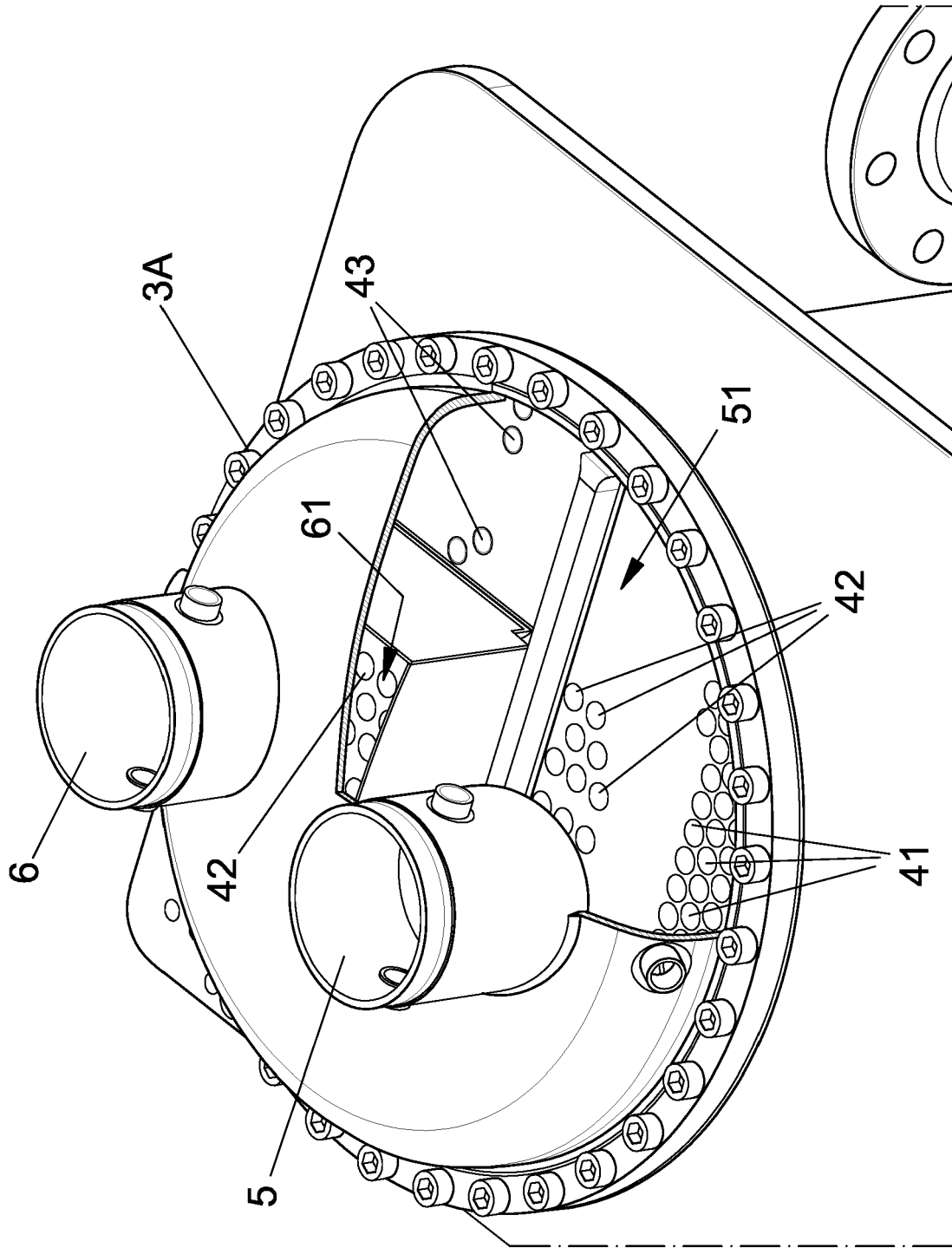

FIG. 8

REFERENCES CITED IN THE DESCRIPTION

This list of references cited by the applicant is for the reader's convenience only. It does not form part of the European patent document. Even though great care has been taken in compiling the references, errors or omissions cannot be excluded and the EPO disclaims all liability in this regard.

Patent documents cited in the description

- WO 2011011421 A2 [0008]