



(51) International Patent Classification:  
A61B 17/072 (2006.01)

(21) International Application Number:  
PCT/IB2018/059839

(22) International Filing Date:  
10 December 2018 (10.12.2018)

(25) Filing Language: English

(26) Publication Language: English

(30) Priority Data:  
15/850,505 21 December 2017 (21.12.2017) US

(71) Applicant: ETHICON LLC [US/US]; #475 Street C, Suite 401, Los Frailes Industrial Park, Guaynabo, USA, 00969 (PR).

(72) Inventors: SHELTON, IV, Frederick E.; 4545 Creek Road, Cincinnati, Ohio 45242 (US). MORGAN, Jerome R.; 4545 Creek Road, Cincinnati, Ohio 45242 (US). HAR-

RIS, Jason L.; 4545 Creek Road, Cincinnati, Ohio 45242 (US). WEANER, Lauren S.; 4545 Creek Road, Cincinnati, Ohio 45242 (US). VOLZ, Janna B.; 4545 Creek Road, Cincinnati, Ohio 45242 (US). BAKOS, Gregory J.; 4545 Creek Road, Cincinnati, Ohio 45242 (US). ZEINER, Mark S.; 4545 Creek Road, Cincinnati, Ohio 45242 (US).

(74) Agent: SHIRTZ, Joseph F. et al.; Johnson & Johnson, One Johnson & Johnson Plaza, New Brunswick, New Jersey 08933 (US).

(81) Designated States (unless otherwise indicated, for every kind of national protection available): AE, AG, AL, AM, AO, AT, AU, AZ, BA, BB, BG, BH, BN, BR, BW, BY, BZ, CA, CH, CL, CN, CO, CR, CU, CZ, DE, DJ, DK, DM, DO, DZ, EC, EE, EG, ES, FI, GB, GD, GE, GH, GM, GT, HN, HR, HU, ID, IL, IN, IR, IS, JO, JP, KE, KG, KH, KN, KP, KR, KW, KZ, LA, LC, LK, LR, LS, LU, LY, MA, MD, ME, MG, MK, MN, MW, MX, MY, MZ, NA, NG, NI, NO, NZ, OM, PA, PE, PG, PH, PL, PT, QA, RO, RS, RU, RW, SA,

(54) Title: STAPLING INSTRUMENT COMPRISING A TISSUE DRIVE

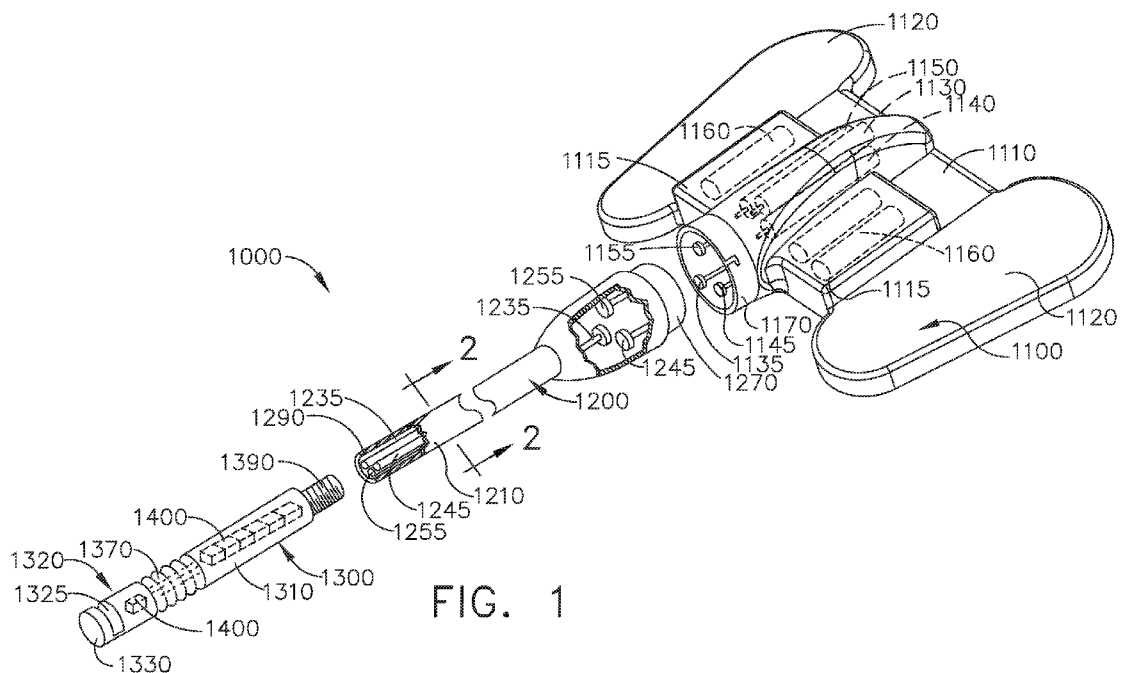

FIG. 1

(57) Abstract: A surgical stapler for stapling the tissue of a patient is disclosed. The surgical stapler comprises a handle, a shaft extending from the handle, a plurality of staple cartridges, and an end effector comprising a tissue compression surface and an anvil comprising staple forming pockets, wherein the anvil is movable toward the tissue compression surface during a closing motion. The surgical stapler further comprises an anvil closing system configured to move the anvil through the closing motion, a staple firing system configured to deploy the staple cartridges along a path, and means for gripping the patient tissue and creating relative movement between the end effector and the patient tissue to re-position the end effector along the path.



SC, SD, SE, SG, SK, SL, SM, ST, SV, SY, TH, TJ, TM, TN,  
TR, TT, TZ, UA, UG, US, UZ, VC, VN, ZA, ZM, ZW.

- (84) Designated States** (*unless otherwise indicated, for every kind of regional protection available*): ARIPO (BW, GH, GM, KE, LR, LS, MW, MZ, NA, RW, SD, SL, ST, SZ, TZ, UG, ZM, ZW), Eurasian (AM, AZ, BY, KG, KZ, RU, TJ, TM), European (AL, AT, BE, BG, CH, CY, CZ, DE, DK, EE, ES, FI, FR, GB, GR, HR, HU, IE, IS, IT, LT, LU, LV, MC, MK, MT, NL, NO, PL, PT, RO, RS, SE, SI, SK, SM, TR), OAPI (BF, BJ, CF, CG, CI, CM, GA, GN, GQ, GW, KM, ML, MR, NE, SN, TD, TG).

**Declarations under Rule 4.17:**

- *as to applicant's entitlement to apply for and be granted a patent (Rule 4.17(ii))*
- *as to the applicant's entitlement to claim the priority of the earlier application (Rule 4.17(iii))*

**Published:**

- *with international search report (Art. 21(3))*
- *in black and white; the international application as filed contained color or greyscale and is available for download from PATENTSCOPE*

## TITLE

### STAPLING INSTRUMENT COMPRISING A TISSUE DRIVE

#### BACKGROUND

**[0001]** The present invention relates to surgical instruments and, in various arrangements, to surgical stapling and cutting instruments and staple cartridges for use therewith that are designed to staple and cut tissue.

#### BRIEF DESCRIPTION OF THE DRAWINGS

**[0002]** Various features of the embodiments described herein, together with advantages thereof, may be understood in accordance with the following description taken in conjunction with the accompanying drawings as follows:

**[0003]** FIG. 1 is a perspective view of a surgical stapling instrument in accordance with at least one embodiment;

**[0004]** FIG. 2 is a cross-sectional view of the stapling instrument of FIG. 1 taken along line 2-2 in FIG. 1;

**[0005]** FIG. 3 is a partial perspective view of a drive system of the stapling instrument of FIG. 1;

**[0006]** FIG. 4 is a plan view of the drive system of FIG. 3;

**[0007]** FIG. 5 is an elevational view of the drive system of FIG. 3 illustrated in a first operational configuration;

**[0008]** FIG. 6 is a side elevational view of the drive system of FIG. 3 illustrated in the first operational configuration of FIG. 5;

**[0009]** FIG. 7 is a side elevational view of the drive system of FIG. 3 illustrated in a second operational configuration;

**[0010]** FIG. 8 is a partial perspective view of a surgical stapling instrument in accordance with at least one embodiment;

- [0011]** FIG. 9 is a partial perspective view of a surgical stapling instrument in accordance with at least one embodiment;
- [0012]** FIG. 10 is a perspective view of a handle housing of the stapling instrument of FIG. 8;
- [0013]** FIG. 11 is a perspective view of a battery in accordance with at least one embodiment;
- [0014]** FIG. 12 is a perspective view of a handle of the stapling instrument of FIG. 1;
- [0015]** FIG. 13 is a partial perspective view of a surgical stapling instrument including a display in accordance with at least one embodiment;
- [0016]** FIG. 14 depicts a status control on the display of FIG. 13;
- [0017]** FIG. 15 depicts a speed control on the display of FIG. 13;
- [0018]** FIG. 16 depicts a fault threshold control on the display of FIG. 13;
- [0019]** FIG. 17 depicts a direction control on the display of FIG. 13;
- [0020]** FIG. 18 depicts the display of FIG. 13 and the speed control of FIG. 15;
- [0021]** FIG. 19 depicts the display of FIG. 13 and a speed control;
- [0022]** FIG. 20 depicts the display of FIG. 13 and a staple path control being used to alter the staple firing path of the stapling instrument;
- [0023]** FIG. 21 depicts the display of FIG. 13 and the staple path control of FIG. 21 being used to control the staple firing path of the stapling instrument;
- [0024]** FIG. 22 depicts the display of FIG. 13 and a control for stopping the stapling instrument along the staple firing path;
- [0025]** FIG. 23 depicts a surgical instrument system including an external, or off-board, display in accordance with at least one embodiment;
- [0026]** FIG. 24 depicts a display of a surgical stapling instrument in accordance in at least one embodiment;
- [0027]** FIG. 25 depicts the display of FIG. 24 being used to change a staple firing path when creating a stomach sleeve during a stomach reduction procedure;
- [0028]** FIG. 26 depicts a joystick being used to change a staple firing path on the display of FIG. 24;
- [0029]** FIG. 27 depicts the stapling instrument being guided along a staple firing path;
- [0030]** FIG. 28 depicts the stomach of a patient;

- [0031]** FIG. 29 is a cross-sectional view of the stomach of a patient;
- [0032]** FIG. 30 is a cross-sectional view of a target inserted into the stomach of FIG. 29;
- [0033]** FIG. 31 is a cross-sectional view of the stomach of a patient which is thinner than the stomach of FIG. 29;
- [0034]** FIG. 32 is a cross-sectional view of a target inserted into the stomach of FIG. 31;
- [0035]** FIG. 33 depicts various anatomical features which can be referenced during a stomach sleeve procedure;
- [0036]** FIG. 34 is a partial elevational view of a surgical stapling instrument comprising a shaft, an end effector, and an articulation joint in accordance with at least one embodiment;
- [0037]** FIG. 35 is a partial elevational view of the stapling instrument of FIG. 34 illustrating the end effector in an articulated position;
- [0038]** FIG. 36 is a bottom cross-sectional view of an end effector of a surgical stapling instrument in accordance with at least one embodiment;
- [0039]** FIG. 37 is a partial cross-sectional view of a surgical stapling instrument comprising a tissue drive system in accordance with at least one embodiment;
- [0040]** FIG. 38 is a partial cross-sectional view of the stapling instrument of FIG. 37 illustrating the tissue drive system engaged with the tissue of a patient;
- [0041]** FIG. 39 is a partial cross-sectional view of the stapling instrument of FIG. 37 illustrating the tissue drive system pushing the patient tissue in a first direction;
- [0042]** FIG. 40 is a partial cross-sectional view of the stapling instrument of FIG. 37 illustrating the tissue drive system pushing the patient tissue in a second direction;
- [0043]** FIG. 41 is a partial cross-sectional view of the stapling instrument of FIG. 37 illustrating the tissue drive system being disengaged from the patient tissue;
- [0044]** FIG. 42 is a partial elevational view of a drive system including a synchronizing mechanism in accordance with at least one embodiment;
- [0045]** FIG. 43 illustrates the synchronizing mechanism of FIG. 42 actuating an end effector drive system;

- [0046]** FIG. 44 illustrates a drive system configured to reciprocatingly drive a plurality of end effector drive system;
- [0047]** FIG. 45 depicts plots of two synchronized end effector drives;
- [0048]** FIG. 46 is a table illustrating the synchronization of four end effector drives;
- [0049]** FIGS. 47A-47G illustrate the operational steps of a surgical stapling instrument in accordance with at least one embodiment;
- [0050]** FIG. 48 is a table illustrating the synchronization of the end effector drives of a surgical stapling instrument in accordance with at least one embodiment;
- [0051]** FIG. 49 is a module for operating a surgical stapling instrument in accordance with at least one embodiment;
- [0052]** FIG. 50 is a partial perspective view of an end effector including a tissue drive system in accordance with at least one embodiment illustrated being extended;
- [0053]** FIG. 51 is a partial perspective view of the tissue drive system of FIG. 50 being retracted;
- [0054]** FIG. 52 is a partial cross-sectional view of the end effector of FIG. 50 illustrating the tissue drive system in a retracted configuration;
- [0055]** FIG. 53 is a partial cross-sectional view of the end effector of FIG. 50 illustrating the tissue drive system in a lowered configuration;
- [0056]** FIG. 54 is a partial cross-sectional view of the end effector of FIG. 50 illustrating the tissue drive system being extended;
- [0057]** FIG. 55 is a partial cross-sectional view of the end effector of FIG. 50 illustrating teeth of the tissue drive system in a protruded configuration;
- [0058]** FIG. 56 is a partial cross-sectional view of the end effector of FIG. 50 illustrating the drive system being retracted;
- [0059]** FIG. 57 is a partial perspective view of a tissue drive system in accordance with at least one embodiment;
- [0060]** FIG. 58 is a partial perspective view of the tissue drive system of FIG. 57 in an extended configuration;
- [0061]** FIGS. 59A-59D illustrate the operational steps of a tissue drive system of a surgical stapling instrument in accordance with at least one embodiment;

- [0062]** FIGS. 60A-60D further illustrate the operational steps of the tissue drive system of FIGS. 59A-59D;
- [0063]** FIG. 61 is a partial perspective view of a surgical stapling instrument including a tissue drive system in accordance with at least one embodiment;
- [0064]** FIG. 62 is a partial perspective view of the tissue drive system of FIG. 61 in an extended configuration;
- [0065]** FIG. 63 is a partial cross-sectional perspective view of a surgical stapling instrument comprising a tissue drive system in accordance with at least one embodiment;
- [0066]** FIG. 64 is a bottom cross-sectional plan view of the stapling instrument of FIG. 63;
- [0067]** FIG. 65 is a partial cross-sectional view of a surgical stapling instrument including a vacuum system in accordance with at least one embodiment;
- [0068]** FIG. 66 is a partial detail view of a tissue drive system of the stapling instrument of FIG. 65;
- [0069]** FIG. 67 is a partial cross-sectional view of the stapling instrument of FIG. 65 illustrating tissue being pulled into the end effector of the stapling instrument;
- [0070]** FIG. 68 is a partial detail view of the tissue drive system of FIG. 66;
- [0071]** FIG. 69 is a partial cross-sectional view of the stapling instrument of FIG. 65 illustrating the tissue being released;
- [0072]** FIG. 70 is a partial cross-sectional view of a surgical stapling instrument comprising a vacuum system in accordance with at least one embodiment;
- [0073]** FIG. 71 is a partial cross-sectional view of the stapling instrument of FIG. 70 illustrating first and second drive feet of the stapling instrument in a retracted configuration;
- [0074]** FIG. 72 is a partial cross-sectional view of the stapling instrument of FIG. 70 illustrating the first drive foot in an extended position;
- [0075]** FIG. 73 is a vacuum manifold of the stapling instrument of FIG. 70 in fluid communication with the first drive foot;
- [0076]** FIG. 74 is a partial perspective view of a surgical stapling instrument in accordance with at least one embodiment;

- [0077]** FIGS. 75A-75D depict the operational steps of a surgical stapling instrument in accordance with at least one embodiment;
- [0078]** FIG. 76 is a partial cross-sectional perspective view of a surgical stapling instrument in accordance with at least one embodiment;
- [0079]** FIGS. 77A-77D depict the operational steps for steering the stapling instrument of FIG. 76;
- [0080]** FIG. 78 is a cross-sectional end view of a surgical stapling instrument in accordance with at least one embodiment;
- [0081]** FIG. 79 is a partial elevational view of a surgical stapling instrument in accordance with at least one embodiment comprising a tissue drive;
- [0082]** FIG. 79A illustrates the position of a foot of the tissue drive corresponding with FIG. 79;
- [0083]** FIG. 80 is a partial elevational view of the stapling instrument of FIG. 79 illustrating the foot being extended;
- [0084]** FIG. 80A illustrates the position of the foot of the tissue drive corresponding with FIG. 80;
- [0085]** FIG. 81 is a partial elevational view of the stapling instrument of FIG. 79 illustrating the foot in an extended configuration;
- [0086]** FIG. 81A illustrates the position of the foot of the tissue drive corresponding with FIG. 81;
- [0087]** FIG. 82 is a partial elevational view of the stapling instrument of FIG. 79 illustrating the foot being retracted;
- [0088]** FIG. 82A illustrates the position of the foot of the tissue drive corresponding with FIG. 82;
- [0089]** FIG. 83 is a partial cross-sectional view of the tissue drive of the stapling instrument of FIG. 79;
- [0090]** FIG. 84 illustrates the kinematics of the tissue drive of the stapling instrument of FIG. 79;
- [0091]** FIG. 85 illustrates a cam capable of producing the kinematics of FIG. 84;
- [0092]** FIG. 86 is a perspective view of a cam capable of producing the kinematics of FIG. 84;

**[0093]** FIG. 87 is a partial perspective view of a surgical stapling instrument including a tissue drive in accordance with at least one embodiment;

**[0094]** FIG. 88 depicts a tissue drive of a surgical stapling instrument in accordance with at least one embodiment;

**[0095]** FIG. 89 depicts the tissue drive of FIG. 88 in an extended configuration;

**[0096]** FIGS. 90A-90D depict the operational steps of a surgical stapling instrument including a tissue drive in accordance with at least one embodiment;

**[0097]** FIGS. 91A-91D depict the operational steps of a surgical stapling instrument including a tissue drive in accordance with at least one embodiment;

**[0098]** FIG. 92 depicts a tissue drive of a surgical stapling instrument in accordance with at least one embodiment;

**[0099]** FIG. 93 depicts the tissue drive of FIG. 92 in an extended configuration;

**[0100]** FIG. 94 is a partial cross-sectional perspective view of a surgical stapling instrument in accordance with at least one embodiment;

**[0101]** FIG. 95 is a partial elevational view of a surgical stapling instrument comprising a tissue cutting member in accordance with at least one embodiment;

**[0102]** FIG. 96 depicts the tissue cutting member of FIG. 95 being moved through a tissue cutting stroke;

**[0103]** FIG. 97 is partial perspective view of a surgical stapling instrument in accordance with at least one embodiment;

**[0104]** FIG. 98 is a perspective view of two connected staples in accordance with at least one embodiment;

**[0105]** FIG. 99 is a partial perspective view of the staples of FIG. 98 being separated;

**[0106]** FIG. 100 is a partial cross-sectional view of a staple firing system of the stapling instrument of FIG. 97 including a staple firing chamber in accordance with at least one embodiment;

**[0107]** FIG. 101 illustrates a staple being fired by the staple firing system of FIG. 100;

**[0108]** FIG. 102 illustrates another staple being loaded into the staple firing chamber of FIG. 100;

**[0109]** FIG. 103 is a bottom cross-sectional end view of the stapling instrument of FIG. 97;

- [0110]** FIG. 104 is a partial cross-sectional perspective view of a surgical stapling instrument in accordance with at least one embodiment;
- [0111]** FIGS. 105A-105D depict the operational steps of the stapling system of FIG. 104;
- [0112]** FIG. 106 is a partial perspective view of a surgical stapling instrument in accordance with at least one embodiment;
- [0113]** FIG. 107 is an exploded perspective view of a staple clip for use with the stapling instrument of FIG. 106;
- [0114]** FIG. 108 is a plan view of a staple clip in accordance with at least one embodiment;
- [0115]** FIG. 109 is an end view of the staple clip of FIG. 108 positioned in a surgical stapling instrument;
- [0116]** FIG. 110 is a perspective view of the staple clip of FIG. 108;
- [0117]** FIG. 111 is an end view of a staple clip in accordance with at least one embodiment positioned in a surgical stapling instrument;
- [0118]** FIG. 112 is a perspective view of the staple clip of FIG. 111;
- [0119]** FIG. 113 is an end view of a staple clip in accordance with at least one embodiment positioned in a surgical stapling instrument;
- [0120]** FIG. 114 is a perspective view of the staple clip of FIG. 113;
- [0121]** FIG. 115 is a partial plan view of a staple strip in an unfolded configuration in accordance with at least one embodiment;
- [0122]** FIG. 116 is an end view of the staple strip of FIG. 115 in its unfolded configuration;
- [0123]** FIG. 117 is an end view of the staple strip of FIG. 115 in a folded configuration;
- [0124]** FIG. 118 is a perspective of the staple strip of FIG. 115 being deployed;
- [0125]** FIG. 119 is a perspective view of a staple cluster in accordance with at least one embodiment;
- [0126]** FIG. 120 is a partial perspective view of the staple cluster of FIG. 119 being loaded into a surgical stapling instrument;
- [0127]** FIG. 121 is a partial perspective view of a surgical stapling instrument comprising deployable staple clusters in accordance with at least one embodiment;

- [0128]** FIG. 122 is a partial perspective view of a surgical stapling instrument comprising a tissue drive in accordance with at least one embodiment;
- [0129]** FIG. 123 is a partial perspective view of the stapling instrument of FIG. 122 illustrating the tissue drive in an extended configuration;
- [0130]** FIG. 124 depicts a cross-sectional width of a distal head of the stapling instrument of FIG. 122;
- [0131]** FIG. 125 is a cross-sectional view of a tissue gripping surface of the tissue drive of FIG. 122;
- [0132]** FIG. 126 is a cross-sectional end view of a surgical stapling instrument including a tissue drive in accordance with at least one embodiment illustrated in an extended configuration;
- [0133]** FIG. 127 is a cross-sectional end view of the stapling instrument of FIG. 126 illustrating the tissue drive in a retracted configuration;
- [0134]** FIG. 128 depicts a firing drive of a surgical stapling instrument in accordance with at least one embodiment illustrated in an unfired configuration;
- [0135]** FIG. 128A depicts a tissue drive of the stapling instrument of FIG. 128 illustrated in an extended configuration;
- [0136]** FIG. 129 depicts the firing drive of FIG. 128 illustrated in a fired configuration;
- [0137]** FIG. 129A depicts the tissue drive of FIG. 128A in a retracted configuration;
- [0138]** FIG. 130 depicts the firing drive of FIG. 128 illustrated in its unfired configuration;
- [0139]** FIG. 130A depicts the tissue drive of FIG. 128A in its retracted configuration;
- [0140]** FIG. 131 is a perspective view of a staple loading system of a surgical stapling instrument in accordance with at least one embodiment;
- [0141]** FIG. 132 is a plan view of the staple loading system of FIG. 131;
- [0142]** FIG. 133 is a partial elevational view of the staple loading system of FIG. 131;
- [0143]** FIG. 134 is a partial cross-sectional view of the stapling instrument of FIG. 131 illustrated in an unfired configuration;
- [0144]** FIG. 135 is a partial cross-sectional view of the stapling instrument of FIG. 131 illustrated in a fired configuration;

- [0145]** FIG. 136 is a partial cross-sectional view of the stapling instrument of FIG. 131 being retracted into its unfired configuration;
- [0146]** FIG. 137 is a partial cross-sectional view of the stapling instrument of FIG. 131 illustrated in its unfired configuration;
- [0147]** FIG. 138 depicts a staple pattern that can be produced by a surgical stapling instrument in accordance with at least one embodiment;
- [0148]** FIG. 139 depicts a staple pattern that can be produced by a surgical stapling instrument in accordance with at least one embodiment;
- [0149]** FIG. 140 illustrates a surgical stapling instrument in accordance with at least one embodiment;
- [0150]** FIG. 141 illustrates the operational steps that the stapling instrument of FIG. 140 uses to manufacture and deploy staples;
- [0151]** FIG. 142 depicts a staple firing line in the stomach of a patient;
- [0152]** FIG. 143 depicts a progression of staple firings in accordance with at least one embodiment;
- [0153]** FIGS. 144-146 illustrate the stapling instrument of FIG. 1 being used during a surgical procedure;
- [0154]** FIG. 147 illustrates a surgical stapling instrument in accordance with at least one embodiment being used during a surgical procedure;
- [0155]** FIG. 148 is a partial elevational view of the surgical stapling instrument of FIG. 147;
- [0156]** FIG. 149 is a partial perspective view of the stapling instrument of FIG. 147 in a first configuration;
- [0157]** FIG. 150 is a partial perspective view of the stapling instrument of FIG. 147 in a second configuration;
- [0158]** FIG. 151 depicts a potential outcome of a stomach sleeve procedure using the surgical stapling instruments disclosed herein;
- [0159]** FIG. 152 depicts a guide inserted into the stomach of a patient;
- [0160]** FIG. 153 depicts a guide being used to define a staple firing path in the patient's stomach;

- [0161]** FIG. 154 depicts the guide of FIG. 153 being used to create a stomach sleeve during a gastric bypass procedure;
- [0162]** FIG. 155 is a partial cross-sectional view of the guide of FIG. 153;
- [0163]** FIG. 156 is a partial cross-sectional view of a guide in accordance with at least one embodiment illustrated with some components removed;
- [0164]** FIG. 157 is a schematic of the guide of FIG. 153;
- [0165]** FIG. 158 is a perspective view of a surgical stapling system comprising loadable staple cartridges in accordance with at least one embodiment;
- [0166]** FIG. 159 depicts certain operational components of the stapling system of FIG. 158;
- [0167]** FIG. 160 is an end view of a surgical stapling instrument comprising a projector system including two lenses in accordance with at least one embodiment;
- [0168]** FIG. 161 illustrates the stapling instrument of FIG. 160 being used during a surgical procedure;
- [0169]** FIG. 162 illustrates a surgical stapling system including a projector in accordance with at least one embodiment;
- [0170]** FIG. 163 illustrates a surgical stapling system comprising a vision system and a projection system in accordance with at least one embodiment;
- [0171]** FIG. 164 illustrates the projector system of the stapling system of FIG. 163 being used;
- [0172]** FIG. 165 illustrates a projected image on the tissue of a patient in accordance with at least one embodiment;
- [0173]** FIG. 166 illustrates a staple firing path projected onto the tissue of a patient in accordance with at least one embodiment;
- [0174]** FIG. 167 illustrates a surgical stapling instrument comprising a first projector configured to project a first part of a staple firing path onto the tissue of a patient and a second projector configured to project a second part of the staple firing path onto the tissue of a patient in accordance with at least one embodiment;
- [0175]** FIG. 168 is a partial elevational view of a surgical stapling instrument comprising an articulatable end effector in accordance with at least one embodiment;

**[0176]** FIG. 169 is a partial elevational view of the surgical stapling instrument of FIG. 168;

**[0177]** FIG. 170 is a partial elevational view of a surgical stapling instrument comprising an articulatable end effector and a dampener configured to reduce unintentional movement of the end effector in accordance with at least one embodiment;

**[0178]** FIG. 171 is a partial elevational view of a surgical stapling instrument including an end effector dampener in accordance with at least one embodiment;

**[0179]** FIG. 172 illustrates the stapling instrument of FIG. 171 being used in a surgical procedure;

**[0180]** FIG. 173 illustrates the stapling instrument of FIG. 171 being used in a surgical procedure;

**[0181]** FIG. 174 illustrates a staple firing path created by a surgical stapling instrument comprising a longitudinal end effector;

**[0182]** FIG. 175 illustrates a staple firing path created by a surgical stapling instrument disclosed herein;

**[0183]** FIG. 176 illustrates a staple firing path created by a surgical stapling instrument comprising a longitudinal end effector;

**[0184]** FIG. 177 illustrates a staple firing path created by a surgical stapling instrument disclosed herein;

**[0185]** FIG. 178 illustrates a staple firing path created by a surgical stapling instrument comprising a longitudinal end effector;

**[0186]** FIG. 179 illustrates a staple firing path created by a surgical stapling instrument disclosed herein;

**[0187]** FIG. 180 is a perspective view of a handle of a surgical instrument in accordance with at least one embodiment;

**[0188]** FIG. 181 is a perspective view of the handle of the surgical instrument of FIG. 180 enclosed in a sterile barrier;

**[0189]** FIG. 182 is a partial cross-sectional view of the sterile barrier and a touch-sensitive display of the handle of FIG. 181;

**[0190]** FIG. 183 is a plan view of the touch-sensitive display of FIG. 182 illustrating a grid of electrodes, wherein a plurality of pixels is activated; and

**[0191]** FIG. 184 is a graph depicting a relationship between the location of the active pixels of FIG. 183 and the capacitance detected by the touch-sensitive display of FIG. 182.

**[0192]** Corresponding reference characters indicate corresponding parts throughout the several views. The exemplifications set out herein illustrate various embodiments of the invention, in one form, and such exemplifications are not to be construed as limiting the scope of the invention in any manner.

### **DETAILED DESCRIPTION**

**[0193]** Applicant of the present application owns the following U.S. Patent Applications that were filed on December 21, 2017 and which are each herein incorporated by reference in their respective entireties:

- U.S. Patent Application Serial No. 15/850,431, entitled CONTINUOUS USE SELF-PROPELLED STAPLING INSTRUMENT;
- U.S. Patent Application Serial No. 15/850,461, entitled SURGICAL INSTRUMENT COMPRISING SPEED CONTROL;
- U.S. Patent Application Serial No. 15/850,433, entitled SURGICAL INSTRUMENT COMPRISING A PROJECTOR;
- U.S. Patent Application Serial No. 15/850,495, entitled STAPLE INSTRUMENT COMPRISING A FIRING PATH DISPLAY;
- U.S. Patent Application Serial No. 15/850,480, entitled SELF-GUIDING STAPLING INSTRUMENT;
- U.S. Patent Application Serial No. 15/850,522, entitled SURGICAL INSTRUMENT CONFIGURED TO DETERMINE FIRING PATH;
- U.S. Patent Application Serial No. 15/850,542, entitled SURGICAL INSTRUMENT COMPRISING AN END EFFECTOR DAMPENER;
- U.S. Patent Application Serial No. 15/850,579, entitled SURGICAL INSTRUMENT COMPRISING SYNCHRONIZED DRIVE SYSTEMS;

- U.S. Patent Application Serial No. 15/850,534, entitled SURGICAL INSTRUMENT COMPRISING A TISSUE GRASPING SYSTEM;
- U.S. Patent Application Serial No. 15/850,562, entitled SURGICAL INSTRUMENT COMPRISING SEQUENCED SYSTEMS;
- U.S. Patent Application Serial No. 15/850,587, entitled STAPLING INSTRUMENT COMPRISING A STAPLE FEEDING SYSTEM;
- U.S. Patent Application Serial No. 15/850,508, entitled SURGICAL STAPLER COMPRISING STORABLE CARTRIDGES HAVING DIFFERENT STAPLE SIZES;
- U.S. Patent Application Serial No. 15/850,526, entitled SURGICAL INSTRUMENT HAVING A DISPLAY COMPRISING IMAGE LAYERS;
- U.S. Patent Application Serial No. 15/850,529, entitled SURGICAL INSTRUMENT COMPRISING A DISPLAY;
- U.S. Patent Application Serial No. 15/850,500, entitled SURGICAL INSTRUMENT COMPRISING AN ARTICULATABLE DISTAL HEAD; and
- U.S. Patent Application Serial No. 15/850,518, entitled SURGICAL INSTRUMENT COMPRISING A PIVOTABLE DISTAL HEAD.

**[0194]** Applicant of the present application owns the following U.S. Patent Applications that were filed on December 19, 2017 and which are each herein incorporated by reference in their respective entireties:

- U.S. Patent Application Serial No. 15/847,306, entitled METHOD FOR DETERMINING THE POSITION OF A ROTATABLE JAW OF A SURGICAL INSTRUMENT ATTACHMENT ASSEMBLY;
- U.S. Patent Application Serial No. 15/847,297, entitled SURGICAL INSTRUMENTS WITH DUAL ARTICULATION DRIVERS;
- U.S. Patent Application Serial No. 15/847,325, entitled SURGICAL TOOLS CONFIGURED FOR INTERCHANGEABLE USE WITH DIFFERENT CONTROLLER INTERFACES;
- U.S. Patent Application Serial No. 15/847,293, entitled SURGICAL INSTRUMENT COMPRISING CLOSURE AND FIRING LOCKING MECHANISM;
- U.S. Patent Application Serial No. 15/847,315, entitled ROBOTIC ATTACHMENT COMPRISING EXTERIOR DRIVE ACTUATOR; and

- U.S. Design Patent Application Serial No. 29/630,115, entitled SURGICAL INSTRUMENT ASSEMBLY.

**[0195]** Applicant of the present application owns the following U.S. Patent Applications that were filed on December 15, 2017 and which are each herein incorporated by reference in their respective entireties:

- U.S. Patent Application Serial No. 15/843,485, entitled SEALED ADAPTERS FOR USE WITH ELECTROMECHANICAL SURGICAL INSTRUMENTS;
- U.S. Patent Application Serial No. 15/843,518, entitled END EFFECTORS WITH POSITIVE JAW OPENING FEATURES FOR USE WITH ADAPTERS FOR ELECTROMECHANICAL SURGICAL INSTRUMENTS;
- U.S. Patent Application Serial No. 15/843,535, entitled SURGICAL END EFFECTORS WITH CLAMPING ASSEMBLIES CONFIGURED TO INCREASE JAW APERTURE RANGES;
- U.S. Patent Application Serial No. 15/843,558, entitled SURGICAL END EFFECTORS WITH PIVOTAL JAWS CONFIGURED TO TOUCH AT THEIR RESPECTIVE DISTAL ENDS WHEN FULLY CLOSED;
- U.S. Patent Application Serial No. 15/843,528, entitled SURGICAL END EFFECTORS WITH JAW STIFFENER ARRANGEMENTS CONFIGURED TO PERMIT MONITORING OF FIRING MEMBER;
- U.S. Patent Application Serial No. 15/843,567, entitled ADAPTERS WITH END EFFECTOR POSITION SENSING AND CONTROL ARRANGEMENTS FOR USE IN CONNECTION WITH ELECTROMECHANICAL SURGICAL INSTRUMENTS;
- U.S. Patent Application Serial No. 15/843,556, entitled DYNAMIC CLAMPING ASSEMBLIES WITH IMPROVED WEAR CHARACTERISTICS FOR USE IN CONNECTION WITH ELECTROMECHANICAL SURGICAL INSTRUMENTS;
- U.S. Patent Application Serial No. 15/843,514, entitled ADAPTERS WITH FIRING STROKE SENSING ARRANGEMENTS FOR USE IN CONNECTION WITH ELECTROMECHANICAL SURGICAL INSTRUMENTS;
- U.S. Patent Application Serial No. 15/843,501, entitled ADAPTERS WITH CONTROL SYSTEMS FOR CONTROLLING MULTIPLE MOTORS OF AN ELECTROMECHANICAL SURGICAL INSTRUMENT;

- U.S. Patent Application Serial No. 15/843,508, entitled HANDHELD ELECTROMECHANICAL SURGICAL INSTRUMENTS WITH IMPROVED MOTOR CONTROL ARRANGEMENTS FOR POSITIONING COMPONENTS OF AN ADAPTER COUPLED THERETO;
- U.S. Patent Application Serial No. 15/843,682, entitled SYSTEMS AND METHODS OF CONTROLLING A CLAMPING MEMBER FIRING RATE OF A SURGICAL INSTRUMENT;
- U.S. Patent Application Serial No. 15/843,689, entitled SYSTEMS AND METHODS OF CONTROLLING A CLAMPING MEMBER; and
- U.S. Patent Application Serial No. 15/843,704, entitled METHODS OF OPERATING SURGICAL END EFFECTORS.

**[0196]** Applicant of the present application owns the following U.S. Patent Applications that were filed on June 29, 2017 and which are each herein incorporated by reference in their respective entireties:

- U.S. Patent Application Serial No. 15/636,829, entitled CLOSED LOOP VELOCITY CONTROL TECHNIQUES FOR ROBOTIC SURGICAL INSTRUMENT;
- U.S. Patent Application Serial No. 15/636,837, entitled CLOSED LOOP VELOCITY CONTROL TECHNIQUES BASED ON SENSED TISSUE PARAMETERS FOR ROBOTIC SURGICAL INSTRUMENT;
- U.S. Patent Application Serial No. 15/636,844, entitled CLOSED LOOP VELOCITY CONTROL OF CLOSURE MEMBER FOR ROBOTIC SURGICAL INSTRUMENT;
- U.S. Patent Application Serial No. 15/636,854, entitled ROBOTIC SURGICAL INSTRUMENT WITH CLOSED LOOP FEEDBACK TECHNIQUES FOR ADVANCEMENT OF CLOSURE MEMBER DURING FIRING; and
- U.S. Patent Application Serial No. 15/636,858, entitled SYSTEM FOR CONTROLLING ARTICULATION FORCES.

**[0197]** Applicant of the present application owns the following U.S. Patent Applications that were filed on June 28, 2017 and which are each herein incorporated by reference in their respective entireties:

- U.S. Patent Application Serial No. 15/635,693, entitled SURGICAL INSTRUMENT COMPRISING AN OFFSET ARTICULATION JOINT;
- U.S. Patent Application Serial No. 15/635,729, entitled SURGICAL INSTRUMENT COMPRISING AN ARTICULATION SYSTEM RATIO;
- U.S. Patent Application Serial No. 15/635,785, entitled SURGICAL INSTRUMENT COMPRISING AN ARTICULATION SYSTEM RATIO;
- U.S. Patent Application Serial No. 15/635,808, entitled SURGICAL INSTRUMENT COMPRISING FIRING MEMBER SUPPORTS;
- U.S. Patent Application Serial No. 15/635,837, entitled SURGICAL INSTRUMENT COMPRISING AN ARTICULATION SYSTEM LOCKABLE TO A FRAME;
- U.S. Patent Application Serial No. 15/635,941, entitled SURGICAL INSTRUMENT COMPRISING AN ARTICULATION SYSTEM LOCKABLE BY A CLOSURE SYSTEM;
- U.S. Patent Application Serial No. 15/636,029, entitled SURGICAL INSTRUMENT COMPRISING A SHAFT INCLUDING A HOUSING ARRANGEMENT;
- U.S. Patent Application Serial No. 15/635,958, entitled SURGICAL INSTRUMENT COMPRISING SELECTIVELY ACTUATABLE ROTATABLE COUPLERS;
- U.S. Patent Application Serial No. 15/635,981, entitled SURGICAL STAPLING INSTRUMENTS COMPRISING SHORTENED STAPLE CARTRIDGE NOSES;
- U.S. Patent Application Serial No. 15/636,009, entitled SURGICAL INSTRUMENT COMPRISING A SHAFT INCLUDING A CLOSURE TUBE PROFILE;
- U.S. Patent Application Serial No. 15/635,663, entitled METHOD FOR ARTICULATING A SURGICAL INSTRUMENT;
- U.S. Patent Application Serial No. 15/635,530, entitled SURGICAL INSTRUMENTS WITH ARTICULATABLE END EFFECTOR WITH AXIALLY SHORTENED ARTICULATION JOINT CONFIGURATIONS;
- U.S. Patent Application Serial No. 15/635,549, entitled SURGICAL INSTRUMENTS WITH OPEN AND CLOSABLE JAWS AND AXIALLY MOVABLE

FIRING MEMBER THAT IS INITIALLY PARKED IN CLOSE PROXIMITY TO THE JAWS PRIOR TO FIRING;

- U.S. Patent Application Serial No. 15/635,559, entitled SURGICAL INSTRUMENTS WITH JAWS CONSTRAINED TO PIVOT ABOUT AN AXIS UPON CONTACT WITH A CLOSURE MEMBER THAT IS PARKED IN CLOSE PROXIMITY TO THE PIVOT AXIS;
- U.S. Patent Application Serial No. 15/635,578, entitled SURGICAL END EFFECTORS WITH IMPROVED JAW APERTURE ARRANGEMENTS;
- U.S. Patent Application Serial No. 15/635,594, entitled SURGICAL CUTTING AND FASTENING DEVICES WITH PIVOTABLE ANVIL WITH A TISSUE LOCATING ARRANGEMENT IN CLOSE PROXIMITY TO AN ANVIL PIVOT;
- U.S. Patent Application Serial No. 15/635,612, entitled JAW RETAINER ARRANGEMENT FOR RETAINING A PIVOTABLE SURGICAL INSTRUMENT JAW IN PIVOTABLE RETAINING ENGAGEMENT WITH A SECOND SURGICAL INSTRUMENT JAW;
- U.S. Patent Application Serial No. 15/635,621, entitled SURGICAL INSTRUMENT WITH POSITIVE JAW OPENING FEATURES;
- U.S. Patent Application Serial No. 15/635,631, entitled SURGICAL INSTRUMENT WITH AXIALLY MOVABLE CLOSURE MEMBER;
- U.S. Patent Application Serial No. 15/635,521, entitled SURGICAL INSTRUMENT LOCKOUT ARRANGEMENT;
- U.S. Design Patent Application Serial No. 29/609,087, entitled STAPLE FORMING ANVIL;
- U.S. Design Patent Application Serial No. 29/609,083, entitled SURGICAL INSTRUMENT SHAFT; and
- U.S. Design Patent Application Serial No. 29/609,093, entitled SURGICAL FASTENER CARTRIDGE.

**[0198]** Applicant of the present application owns the following U.S. Patent Applications that were filed on June 27, 2017 and which are each herein incorporated by reference in their respective entireties:

- U.S. Patent Application Serial No. 15/634,024, entitled SURGICAL ANVIL MANUFACTURING METHODS;
- U.S. Patent Application Serial No. 15/634,035, entitled SURGICAL ANVIL ARRANGEMENTS;
- U.S. Patent Application Serial No. 15/634,046, entitled SURGICAL ANVIL ARRANGEMENTS;
- U.S. Patent Application Serial No. 15/634,054, entitled SURGICAL ANVIL ARRANGEMENTS;
- U.S. Patent Application Serial No. 15/634,068, entitled SURGICAL FIRING MEMBER ARRANGEMENTS;
- U.S. Patent Application Serial No. 15/634,076, entitled STAPLE FORMING POCKET ARRANGEMENTS;
- U.S. Patent Application Serial No. 15/634,090, entitled STAPLE FORMING POCKET ARRANGEMENTS;
- U.S. Patent Application Serial No. 15/634,099, entitled SURGICAL END EFFECTORS AND ANVILS; and
- U.S. Patent Application Serial No. 15/634,117, entitled ARTICULATION SYSTEMS FOR SURGICAL INSTRUMENTS.

**[0199]** Applicant of the present application owns the following U.S. Patent Applications that were filed on December 21, 2016 and which are each herein incorporated by reference in their respective entireties:

- U.S. Patent Application Serial No. 15/386,185, entitled SURGICAL STAPLING INSTRUMENTS AND REPLACEABLE TOOL ASSEMBLIES THEREOF;
- U.S. Patent Application Serial No. 15/386,230, entitled ARTICULATABLE SURGICAL STAPLING INSTRUMENTS;
- U.S. Patent Application Serial No. 15/386,221, entitled LOCKOUT ARRANGEMENTS FOR SURGICAL END EFFECTORS;
- U.S. Patent Application Serial No. 15/386,209, entitled SURGICAL END EFFECTORS AND FIRING MEMBERS THEREOF;

- U.S. Patent Application Serial No. 15/386,198, entitled LOCKOUT ARRANGEMENTS FOR SURGICAL END EFFECTORS AND REPLACEABLE TOOL ASSEMBLIES;
- U.S. Patent Application Serial No. 15/386,240, entitled SURGICAL END EFFECTORS AND ADAPTABLE FIRING MEMBERS THEREFOR;
- U.S. Patent Application Serial No. 15/385,939, entitled STAPLE CARTRIDGES AND ARRANGEMENTS OF STAPLES AND STAPLE CAVITIES THEREIN;
- U.S. Patent Application Serial No. 15/385,941, entitled SURGICAL TOOL ASSEMBLIES WITH CLUTCHING ARRANGEMENTS FOR SHIFTING BETWEEN CLOSURE SYSTEMS WITH CLOSURE STROKE REDUCTION FEATURES AND ARTICULATION AND FIRING SYSTEMS;
- U.S. Patent Application Serial No. 15/385,943, entitled SURGICAL STAPLING INSTRUMENTS AND STAPLE-FORMING ANVILS;
- U.S. Patent Application Serial No. 15/385,950, entitled SURGICAL TOOL ASSEMBLIES WITH CLOSURE STROKE REDUCTION FEATURES;
- U.S. Patent Application Serial No. 15/385,945, entitled STAPLE CARTRIDGES AND ARRANGEMENTS OF STAPLES AND STAPLE CAVITIES THEREIN;
- U.S. Patent Application Serial No. 15/385,946, entitled SURGICAL STAPLING INSTRUMENTS AND STAPLE-FORMING ANVILS;
- U.S. Patent Application Serial No. 15/385,951, entitled SURGICAL INSTRUMENTS WITH JAW OPENING FEATURES FOR INCREASING A JAW OPENING DISTANCE;
- U.S. Patent Application Serial No. 15/385,953, entitled METHODS OF STAPLING TISSUE;
- U.S. Patent Application Serial No. 15/385,954, entitled FIRING MEMBERS WITH NON-PARALLEL JAW ENGAGEMENT FEATURES FOR SURGICAL END EFFECTORS;
- U.S. Patent Application Serial No. 15/385,955, entitled SURGICAL END EFFECTORS WITH EXPANDABLE TISSUE STOP ARRANGEMENTS;
- U.S. Patent Application Serial No. 15/385,948, entitled SURGICAL STAPLING INSTRUMENTS AND STAPLE-FORMING ANVILS;

- U.S. Patent Application Serial No. 15/385,956, entitled SURGICAL INSTRUMENTS WITH POSITIVE JAW OPENING FEATURES;
- U.S. Patent Application Serial No. 15/385,958, entitled SURGICAL INSTRUMENTS WITH LOCKOUT ARRANGEMENTS FOR PREVENTING FIRING SYSTEM ACTUATION UNLESS AN UNSPENT STAPLE CARTRIDGE IS PRESENT;
- U.S. Patent Application Serial No. 15/385,947, entitled STAPLE CARTRIDGES AND ARRANGEMENTS OF STAPLES AND STAPLE CAVITIES THEREIN;
- U.S. Patent Application Serial No. 15/385,896, entitled METHOD FOR RESETTING A FUSE OF A SURGICAL INSTRUMENT SHAFT;
- U.S. Patent Application Serial No. 15/385,898, entitled STAPLE FORMING POCKET ARRANGEMENT TO ACCOMMODATE DIFFERENT TYPES OF STAPLES;
- U.S. Patent Application Serial No. 15/385,899, entitled SURGICAL INSTRUMENT COMPRISING IMPROVED JAW CONTROL;
- U.S. Patent Application Serial No. 15/385,901, entitled STAPLE CARTRIDGE AND STAPLE CARTRIDGE CHANNEL COMPRISING WINDOWS DEFINED THEREIN;
- U.S. Patent Application Serial No. 15/385,902, entitled SURGICAL INSTRUMENT COMPRISING A CUTTING MEMBER;
- U.S. Patent Application Serial No. 15/385,904, entitled STAPLE FIRING MEMBER COMPRISING A MISSING CARTRIDGE AND/OR SPENT CARTRIDGE LOCKOUT;
- U.S. Patent Application Serial No. 15/385,905, entitled FIRING ASSEMBLY COMPRISING A LOCKOUT;
- U.S. Patent Application Serial No. 15/385,907, entitled SURGICAL INSTRUMENT SYSTEM COMPRISING AN END EFFECTOR LOCKOUT AND A FIRING ASSEMBLY LOCKOUT;
- U.S. Patent Application Serial No. 15/385,908, entitled FIRING ASSEMBLY COMPRISING A FUSE;
- U.S. Patent Application Serial No. 15/385,909, entitled FIRING ASSEMBLY COMPRISING A MULTIPLE FAILED-STATE FUSE;

- U.S. Patent Application Serial No. 15/385,920, entitled STAPLE FORMING POCKET ARRANGEMENTS;
- U.S. Patent Application Serial No. 15/385,913, entitled ANVIL ARRANGEMENTS FOR SURGICAL STAPLE/FASTENERS;
- U.S. Patent Application Serial No. 15/385,914, entitled METHOD OF DEFORMING STAPLES FROM TWO DIFFERENT TYPES OF STAPLE CARTRIDGES WITH THE SAME SURGICAL STAPLING INSTRUMENT;
- U.S. Patent Application Serial No. 15/385,893, entitled BILATERALLY ASYMMETRIC STAPLE FORMING POCKET PAIRS;
- U.S. Patent Application Serial No. 15/385,929, entitled CLOSURE MEMBERS WITH CAM SURFACE ARRANGEMENTS FOR SURGICAL INSTRUMENTS WITH SEPARATE AND DISTINCT CLOSURE AND FIRING SYSTEMS;
- U.S. Patent Application Serial No. 15/385,911, entitled SURGICAL STAPLE/FASTENERS WITH INDEPENDENTLY ACTUATABLE CLOSING AND FIRING SYSTEMS;
- U.S. Patent Application Serial No. 15/385,927, entitled SURGICAL STAPLING INSTRUMENTS WITH SMART STAPLE CARTRIDGES;
- U.S. Patent Application Serial No. 15/385,917, entitled STAPLE CARTRIDGE COMPRISING STAPLES WITH DIFFERENT CLAMPING BREADTHS;
- U.S. Patent Application Serial No. 15/385,900, entitled STAPLE FORMING POCKET ARRANGEMENTS COMPRISING PRIMARY SIDEWALLS AND POCKET SIDEWALLS;
- U.S. Patent Application Serial No. 15/385,931, entitled NO-CARTRIDGE AND SPENT CARTRIDGE LOCKOUT ARRANGEMENTS FOR SURGICAL STAPLE/FASTENERS;
- U.S. Patent Application Serial No. 15/385,915, entitled FIRING MEMBER PIN ANGLE;
- U.S. Patent Application Serial No. 15/385,897, entitled STAPLE FORMING POCKET ARRANGEMENTS COMPRISING ZONED FORMING SURFACE GROOVES;

- U.S. Patent Application Serial No. 15/385,922, entitled SURGICAL INSTRUMENT WITH MULTIPLE FAILURE RESPONSE MODES;
- U.S. Patent Application Serial No. 15/385,924, entitled SURGICAL INSTRUMENT WITH PRIMARY AND SAFETY PROCESSORS;
- U.S. Patent Application Serial No. 15/385,912, entitled SURGICAL INSTRUMENTS WITH JAWS THAT ARE PIVOTABLE ABOUT A FIXED AXIS AND INCLUDE SEPARATE AND DISTINCT CLOSURE AND FIRING SYSTEMS;
- U.S. Patent Application Serial No. 15/385,910, entitled ANVIL HAVING A KNIFE SLOT WIDTH;
- U.S. Patent Application Serial No. 15/385,906, entitled FIRING MEMBER PIN CONFIGURATIONS;
- U.S. Patent Application Serial No. 15/386,188, entitled STEPPED STAPLE CARTRIDGE WITH ASYMMETRICAL STAPLES;
- U.S. Patent Application Serial No. 15/386,192, entitled STEPPED STAPLE CARTRIDGE WITH TISSUE RETENTION AND GAP SETTING FEATURES;
- U.S. Patent Application Serial No. 15/386,206, entitled STAPLE CARTRIDGE WITH DEFORMABLE DRIVER RETENTION FEATURES;
- U.S. Patent Application Serial No. 15/386,226, entitled DURABILITY FEATURES FOR END EFFECTORS AND FIRING ASSEMBLIES OF SURGICAL STAPLING INSTRUMENTS;
- U.S. Patent Application Serial No. 15/386,222, entitled SURGICAL STAPLING INSTRUMENTS HAVING END EFFECTORS WITH POSITIVE OPENING FEATURES;
- U.S. Patent Application Serial No. 15/386,236, entitled CONNECTION PORTIONS FOR DISPOSABLE LOADING UNITS FOR SURGICAL STAPLING INSTRUMENTS;
- U.S. Patent Application Serial No. 15/385,887, entitled METHOD FOR ATTACHING A SHAFT ASSEMBLY TO A SURGICAL INSTRUMENT AND, ALTERNATIVELY, TO A SURGICAL ROBOT;
- U.S. Patent Application Serial No. 15/385,889, entitled SHAFT ASSEMBLY COMPRISING A MANUALLY-OPERABLE RETRACTION SYSTEM FOR USE WITH A MOTORIZED SURGICAL INSTRUMENT SYSTEM;

- U.S. Patent Application Serial No. 15/385,890, entitled SHAFT ASSEMBLY COMPRISING SEPARATELY ACTUATABLE AND RETRACTABLE SYSTEMS;
- U.S. Patent Application Serial No. 15/385,891, entitled SHAFT ASSEMBLY COMPRISING A CLUTCH CONFIGURED TO ADAPT THE OUTPUT OF A ROTARY FIRING MEMBER TO TWO DIFFERENT SYSTEMS;
- U.S. Patent Application Serial No. 15/385,892, entitled SURGICAL SYSTEM COMPRISING A FIRING MEMBER ROTATABLE INTO AN ARTICULATION STATE TO ARTICULATE AN END EFFECTOR OF THE SURGICAL SYSTEM;
- U.S. Patent Application Serial No. 15/385,894, entitled SHAFT ASSEMBLY COMPRISING A LOCKOUT;
- U.S. Patent Application Serial No. 15/385,895, entitled SHAFT ASSEMBLY COMPRISING FIRST AND SECOND ARTICULATION LOCKOUTS;
- U.S. Patent Application Serial No. 15/385,916, entitled SURGICAL STAPLING SYSTEMS;
- U.S. Patent Application Serial No. 15/385,918, entitled SURGICAL STAPLING SYSTEMS;
- U.S. Patent Application Serial No. 15/385,919, entitled SURGICAL STAPLING SYSTEMS;
- U.S. Patent Application Serial No. 15/385,921, entitled SURGICAL STAPLE/FASTENER CARTRIDGE WITH MOVABLE CAMMING MEMBER CONFIGURED TO DISENGAGE FIRING MEMBER LOCKOUT FEATURES;
- U.S. Patent Application Serial No. 15/385,923, entitled SURGICAL STAPLING SYSTEMS;
- U.S. Patent Application Serial No. 15/385,925, entitled JAW ACTUATED LOCK ARRANGEMENTS FOR PREVENTING ADVANCEMENT OF A FIRING MEMBER IN A SURGICAL END EFFECTOR UNLESS AN UNFIRED CARTRIDGE IS INSTALLED IN THE END EFFECTOR;
- U.S. Patent Application Serial No. 15/385,926, entitled AXIALLY MOVABLE CLOSURE SYSTEM ARRANGEMENTS FOR APPLYING CLOSURE MOTIONS TO JAWS OF SURGICAL INSTRUMENTS;

- U.S. Patent Application Serial No. 15/385,928, entitled PROTECTIVE COVER ARRANGEMENTS FOR A JOINT INTERFACE BETWEEN A MOVABLE JAW AND ACTUATOR SHAFT OF A SURGICAL INSTRUMENT;
- U.S. Patent Application Serial No. 15/385,930, entitled SURGICAL END EFFECTOR WITH TWO SEPARATE COOPERATING OPENING FEATURES FOR OPENING AND CLOSING END EFFECTOR JAWS;
- U.S. Patent Application Serial No. 15/385,932, entitled ARTICULATABLE SURGICAL END EFFECTOR WITH ASYMMETRIC SHAFT ARRANGEMENT;
- U.S. Patent Application Serial No. 15/385,933, entitled ARTICULATABLE SURGICAL INSTRUMENT WITH INDEPENDENT PIVOTABLE LINKAGE DISTAL OF AN ARTICULATION LOCK;
- U.S. Patent Application Serial No. 15/385,934, entitled ARTICULATION LOCK ARRANGEMENTS FOR LOCKING AN END EFFECTOR IN AN ARTICULATED POSITION IN RESPONSE TO ACTUATION OF A JAW CLOSURE SYSTEM;
- U.S. Patent Application Serial No. 15/385,935, entitled LATERALLY ACTUATABLE ARTICULATION LOCK ARRANGEMENTS FOR LOCKING AN END EFFECTOR OF A SURGICAL INSTRUMENT IN AN ARTICULATED CONFIGURATION; and
- U.S. Patent Application Serial No. 15/385,936, entitled ARTICULATABLE SURGICAL INSTRUMENTS WITH ARTICULATION STROKE AMPLIFICATION FEATURES.

**[0200]** Applicant of the present application owns the following U.S. Patent Applications that were filed on June 24, 2016 and which are each herein incorporated by reference in their respective entireties:

- U.S. Patent Application Serial No. 15/191,775, entitled STAPLE CARTRIDGE COMPRISING WIRE STAPLES AND STAMPED STAPLES;
- U.S. Patent Application Serial No. 15/191,807, entitled STAPLING SYSTEM FOR USE WITH WIRE STAPLES AND STAMPED STAPLES;
- U.S. Patent Application Serial No. 15/191,834, entitled STAMPED STAPLES AND STAPLE CARTRIDGES USING THE SAME;

- U.S. Patent Application Serial No. 15/191,788, entitled STAPLE CARTRIDGE COMPRISING OVERDRIVEN STAPLES; and
- U.S. Patent Application Serial No. 15/191,818, entitled STAPLE CARTRIDGE COMPRISING OFFSET LONGITUDINAL STAPLE ROWS.

**[0201]** Applicant of the present application owns the following U.S. Patent Applications that were filed on June 24, 2016 and which are each herein incorporated by reference in their respective entireties:

- U.S. Design Patent Application Serial No. 29/569,218, entitled SURGICAL FASTENER;
- U.S. Design Patent Application Serial No. 29/569,227, entitled SURGICAL FASTENER;
- U.S. Design Patent Application Serial No. 29/569,259, entitled SURGICAL FASTENER CARTRIDGE; and
- U.S. Design Patent Application Serial No. 29/569,264, entitled SURGICAL FASTENER CARTRIDGE.

**[0202]** Applicant of the present application owns the following patent applications that were filed on April 1, 2016 and which are each herein incorporated by reference in their respective entirety:

- U.S. Patent Application Serial No. 15/089,325, entitled METHOD FOR OPERATING A SURGICAL STAPLING SYSTEM, now U.S. Patent Application Publication No. 2017/0281171;
- U.S. Patent Application Serial No. 15/089,321, entitled MODULAR SURGICAL STAPLING SYSTEM COMPRISING A DISPLAY, now U.S. Patent Application Publication No. 2017/0281163;
- U.S. Patent Application Serial No. 15/089,326, entitled SURGICAL STAPLING SYSTEM COMPRISING A DISPLAY INCLUDING A RE-ORIENTABLE DISPLAY FIELD, now U.S. Patent Application Publication No. 2017/0281172;
- U.S. Patent Application Serial No. 15/089,263, entitled SURGICAL INSTRUMENT HANDLE ASSEMBLY WITH RECONFIGURABLE GRIP PORTION, now U.S. Patent Application Publication No. 2017/0281165;

- U.S. Patent Application Serial No. 15/089,262, entitled ROTARY POWERED SURGICAL INSTRUMENT WITH MANUALLY ACTUATABLE BAILOUT SYSTEM, now U.S. Patent Application Publication No. 2017/0281161;
- U.S. Patent Application Serial No. 15/089,277, entitled SURGICAL CUTTING AND STAPLING END EFFECTOR WITH ANVIL CONCENTRIC DRIVE MEMBER, now U.S. Patent Application Publication No. 2017/0281166;
- U.S. Patent Application Serial No. 15/089,296, entitled INTERCHANGEABLE SURGICAL TOOL ASSEMBLY WITH A SURGICAL END EFFECTOR THAT IS SELECTIVELY ROTATABLE ABOUT A SHAFT AXIS, now U.S. Patent Application Publication No. 2017/0281168;
- U.S. Patent Application Serial No. 15/089,258, entitled SURGICAL STAPLING SYSTEM COMPRISING A SHIFTABLE TRANSMISSION, now U.S. Patent Application Publication No. 2017/0281178;
- U.S. Patent Application Serial No. 15/089,278, entitled SURGICAL STAPLING SYSTEM CONFIGURED TO PROVIDE SELECTIVE CUTTING OF TISSUE, now U.S. Patent Application Publication No. 2017/0281162;
- U.S. Patent Application Serial No. 15/089,284, entitled SURGICAL STAPLING SYSTEM COMPRISING A CONTOURABLE SHAFT, now U.S. Patent Application Publication No. 2017/0281186;
- U.S. Patent Application Serial No. 15/089,295, entitled SURGICAL STAPLING SYSTEM COMPRISING A TISSUE COMPRESSION LOCKOUT, now U.S. Patent Application Publication No. 2017/0281187;
- U.S. Patent Application Serial No. 15/089,300, entitled SURGICAL STAPLING SYSTEM COMPRISING AN UNCLAMPING LOCKOUT, now U.S. Patent Application Publication No. 2017/0281179;
- U.S. Patent Application Serial No. 15/089,196, entitled SURGICAL STAPLING SYSTEM COMPRISING A JAW CLOSURE LOCKOUT, now U.S. Patent Application Publication No. 2017/0281183;
- U.S. Patent Application Serial No. 15/089,203, entitled SURGICAL STAPLING SYSTEM COMPRISING A JAW ATTACHMENT LOCKOUT, now U.S. Patent Application Publication No. 2017/0281184;

- U.S. Patent Application Serial No. 15/089,210, entitled SURGICAL STAPLING SYSTEM COMPRISING A SPENT CARTRIDGE LOCKOUT, now U.S. Patent Application Publication No. 2017/0281185;
- U.S. Patent Application Serial No. 15/089,324, entitled SURGICAL INSTRUMENT COMPRISING A SHIFTING MECHANISM, now U.S. Patent Application Publication No. 2017/0281170;
- U.S. Patent Application Serial No. 15/089,335, entitled SURGICAL STAPLING INSTRUMENT COMPRISING MULTIPLE LOCKOUTS, now U.S. Patent Application Publication No. 2017/0281155;
- U.S. Patent Application Serial No. 15/089,339, entitled SURGICAL STAPLING INSTRUMENT, now U.S. Patent Application Publication No. 2017/0281173;
- U.S. Patent Application Serial No. 15/089,253, entitled SURGICAL STAPLING SYSTEM CONFIGURED TO APPLY ANNULAR ROWS OF STAPLES HAVING DIFFERENT HEIGHTS, now U.S. Patent Application Publication No. 2017/0281177;
- U.S. Patent Application Serial No. 15/089,304, entitled SURGICAL STAPLING SYSTEM COMPRISING A GROOVED FORMING POCKET, now U.S. Patent Application Publication No. 2017/0281188;
- U.S. Patent Application Serial No. 15/089,331, entitled ANVIL MODIFICATION MEMBERS FOR SURGICAL STAPLE/FASTENERS, now U.S. Patent Application Publication No. 2017/0281180;
- U.S. Patent Application Serial No. 15/089,336, entitled STAPLE CARTRIDGES WITH ATRAUMATIC FEATURES, now U.S. Patent Application Publication No. 2017/0281164;
- U.S. Patent Application Serial No. 15/089,312, entitled CIRCULAR STAPLING SYSTEM COMPRISING AN INCISABLE TISSUE SUPPORT, now U.S. Patent Application Publication No. 2017/0281189;
- U.S. Patent Application Serial No. 15/089,309, entitled CIRCULAR STAPLING SYSTEM COMPRISING ROTARY FIRING SYSTEM, now U.S. Patent Application Publication No. 2017/0281169; and

- U.S. Patent Application Serial No. 15/089,349, entitled CIRCULAR STAPLING SYSTEM COMPRISING LOAD CONTROL, now U.S. Patent Application Publication No. 2017/0281174.

**[0203]** Applicant of the present application also owns the U.S. Patent Applications identified below which were filed on December 30, 2015 which are each herein incorporated by reference in their respective entirety:

- U.S. Patent Application Serial No. 14/984,488, entitled MECHANISMS FOR COMPENSATING FOR BATTERY PACK FAILURE IN POWERED SURGICAL INSTRUMENTS, now U.S. Patent Application Publication No. 2017/0189018;
- U.S. Patent Application Serial No. 14/984,525, entitled MECHANISMS FOR COMPENSATING FOR DRIVETRAIN FAILURE IN POWERED SURGICAL INSTRUMENTS, now U.S. Patent Application Publication No. 2017/0189019; and
- U.S. Patent Application Serial No. 14/984,552, entitled SURGICAL INSTRUMENTS WITH SEPARABLE MOTORS AND MOTOR CONTROL CIRCUITS, now U.S. Patent Application Publication No. 2017/0189020.

**[0204]** Applicant of the present application also owns the U.S. Patent Applications identified below which were filed on February 9, 2016 which are each herein incorporated by reference in their respective entirety:

- U.S. Patent Application Serial No. 15/019,220, entitled SURGICAL INSTRUMENT WITH ARTICULATING AND AXIALLY TRANSLATABLE END EFFECTOR, now U.S. Patent Application Publication No. 2017/0224333;
- U.S. Patent Application Serial No. 15/019,228, entitled SURGICAL INSTRUMENTS WITH MULTIPLE LINK ARTICULATION ARRANGEMENTS, now U.S. Patent Application Publication No. 2017/0224342;
- U.S. Patent Application Serial No. 15/019,196, entitled SURGICAL INSTRUMENT ARTICULATION MECHANISM WITH SLOTTED SECONDARY CONSTRAINT, now U.S. Patent Application Publication No. 2017/0224330;
- U.S. Patent Application Serial No. 15/019,206, entitled SURGICAL INSTRUMENTS WITH AN END EFFECTOR THAT IS HIGHLY ARTICULATABLE RELATIVE TO AN ELONGATE SHAFT ASSEMBLY, now U.S. Patent Application Publication No. 2017/0224331;

- U.S. Patent Application Serial No. 15/019,215, entitled SURGICAL INSTRUMENTS WITH NON-SYMMETRICAL ARTICULATION ARRANGEMENTS, now U.S. Patent Application Publication No. 2017/0224332;
- U.S. Patent Application Serial No. 15/019,227, entitled ARTICULATABLE SURGICAL INSTRUMENTS WITH SINGLE ARTICULATION LINK ARRANGEMENTS, now U.S. Patent Application Publication No. 2017/0224334;
- U.S. Patent Application Serial No. 15/019,235, entitled SURGICAL INSTRUMENTS WITH TENSIONING ARRANGEMENTS FOR CABLE DRIVEN ARTICULATION SYSTEMS, now U.S. Patent Application Publication No. 2017/0224336;
- U.S. Patent Application Serial No. 15/019,230, entitled ARTICULATABLE SURGICAL INSTRUMENTS WITH OFF-AXIS FIRING BEAM ARRANGEMENTS, now U.S. Patent Application Publication No. 2017/0224335; and
- U.S. Patent Application Serial No. 15/019,245, entitled SURGICAL INSTRUMENTS WITH CLOSURE STROKE REDUCTION ARRANGEMENTS, now U.S. Patent Application Publication No. 2017/0224343.

**[0205]** Applicant of the present application also owns the U.S. Patent Applications identified below which were filed on February 12, 2016 which are each herein incorporated by reference in their respective entirety:

- U.S. Patent Application Serial No. 15/043,254, entitled MECHANISMS FOR COMPENSATING FOR DRIVETRAIN FAILURE IN POWERED SURGICAL INSTRUMENTS;
- U.S. Patent Application Serial No. 15/043,259, entitled MECHANISMS FOR COMPENSATING FOR DRIVETRAIN FAILURE IN POWERED SURGICAL INSTRUMENTS;
- U.S. Patent Application Serial No. 15/043,275, entitled MECHANISMS FOR COMPENSATING FOR DRIVETRAIN FAILURE IN POWERED SURGICAL INSTRUMENTS; and
- U.S. Patent Application Serial No. 15/043,289, entitled MECHANISMS FOR COMPENSATING FOR DRIVETRAIN FAILURE IN POWERED SURGICAL INSTRUMENTS.

**[0206]** Applicant of the present application owns the following patent applications that were filed on June 18, 2015 and which are each herein incorporated by reference in their respective entirety:

- U.S. Patent Application Serial No. 14/742,925, entitled SURGICAL END EFFECTORS WITH POSITIVE JAW OPENING ARRANGEMENTS, now U.S. Patent Application Publication No. 2016/0367256;
- U.S. Patent Application Serial No. 14/742,941, entitled SURGICAL END EFFECTORS WITH DUAL CAM ACTUATED JAW CLOSING FEATURES, now U.S. Patent Application Publication No. 2016/0367248;
- U.S. Patent Application Serial No. 14/742,914, entitled MOVABLE FIRING BEAM SUPPORT ARRANGEMENTS FOR ARTICULATABLE SURGICAL INSTRUMENTS, now U.S. Patent Application Publication No. 2016/0367255;
- U.S. Patent Application Serial No. 14/742,900, entitled ARTICULATABLE SURGICAL INSTRUMENTS WITH COMPOSITE FIRING BEAM STRUCTURES WITH CENTER FIRING SUPPORT MEMBER FOR ARTICULATION SUPPORT, now U.S. Patent Application Publication No. 2016/0367254;
- U.S. Patent Application Serial No. 14/742,885, entitled DUAL ARTICULATION DRIVE SYSTEM ARRANGEMENTS FOR ARTICULATABLE SURGICAL INSTRUMENTS, now U.S. Patent Application Publication No. 2016/0367246; and
- U.S. Patent Application Serial No. 14/742,876, entitled PUSH/PULL ARTICULATION DRIVE SYSTEMS FOR ARTICULATABLE SURGICAL INSTRUMENTS, now U.S. Patent Application Publication No. 2016/0367245.

**[0207]** Applicant of the present application owns the following patent applications that were filed on March 6, 2015 and which are each herein incorporated by reference in their respective entirety:

- U.S. Patent Application Serial No. 14/640,746, entitled POWERED SURGICAL INSTRUMENT, now U.S. Patent No. 9,808,246;
- U.S. Patent Application Serial No. 14/640,795, entitled MULTIPLE LEVEL THRESHOLDS TO MODIFY OPERATION OF POWERED SURGICAL INSTRUMENTS, now U.S. Patent Application Publication No. 2016/02561185;

- U.S. Patent Application Serial No. 14/640,832, entitled ADAPTIVE TISSUE COMPRESSION TECHNIQUES TO ADJUST CLOSURE RATES FOR MULTIPLE TISSUE TYPES, now U.S. Patent Application Publication No. 2016/0256154;
- U.S. Patent Application Serial No. 14/640,935, entitled OVERLAID MULTI SENSOR RADIO FREQUENCY (RF) ELECTRODE SYSTEM TO MEASURE TISSUE COMPRESSION, now U.S. Patent Application Publication No. 2016/0256071;
- U.S. Patent Application Serial No. 14/640,831, entitled MONITORING SPEED CONTROL AND PRECISION INCREMENTING OF MOTOR FOR POWERED SURGICAL INSTRUMENTS, now U.S. Patent Application Publication No. 2016/0256153;
- U.S. Patent Application Serial No. 14/640,859, entitled TIME DEPENDENT EVALUATION OF SENSOR DATA TO DETERMINE STABILITY, CREEP, AND VISCOELASTIC ELEMENTS OF MEASURES, now U.S. Patent Application Publication No. 2016/0256187;
- U.S. Patent Application Serial No. 14/640,817, entitled INTERACTIVE FEEDBACK SYSTEM FOR POWERED SURGICAL INSTRUMENTS, now U.S. Patent Application Publication No. 2016/0256186;
- U.S. Patent Application Serial No. 14/640,844, entitled CONTROL TECHNIQUES AND SUB-PROCESSOR CONTAINED WITHIN MODULAR SHAFT WITH SELECT CONTROL PROCESSING FROM HANDLE, now U.S. Patent Application Publication No. 2016/0256155;
- U.S. Patent Application Serial No. 14/640,837, entitled SMART SENSORS WITH LOCAL SIGNAL PROCESSING, now U.S. Patent Application Publication No. 2016/0256163;
- U.S. Patent Application Serial No. 14/640,765, entitled SYSTEM FOR DETECTING THE MIS-INSERTION OF A STAPLE CARTRIDGE INTO A SURGICAL STAPLE/FASTENER, now U.S. Patent Application Publication No. 2016/0256160;
- U.S. Patent Application Serial No. 14/640,799, entitled SIGNAL AND POWER COMMUNICATION SYSTEM POSITIONED ON A ROTATABLE SHAFT, now U.S. Patent Application Publication No. 2016/0256162; and

- U.S. Patent Application Serial No. 14/640,780, entitled SURGICAL INSTRUMENT COMPRISING A LOCKABLE BATTERY HOUSING, now U.S. Patent Application Publication No. 2016/0256161.

**[0208]** Applicant of the present application owns the following patent applications that were filed on February 27, 2015, and which are each herein incorporated by reference in their respective entirety:

- U.S. Patent Application Serial No. 14/633,576, entitled SURGICAL INSTRUMENT SYSTEM COMPRISING AN INSPECTION STATION, now U.S. Patent Application Publication No. 2016/0249919;

- U.S. Patent Application Serial No. 14/633,546, entitled SURGICAL APPARATUS CONFIGURED TO ASSESS WHETHER A PERFORMANCE PARAMETER OF THE SURGICAL APPARATUS IS WITHIN AN ACCEPTABLE PERFORMANCE BAND, now U.S. Patent Application Publication No. 2016/0249915;

- U.S. Patent Application Serial No. 14/633,560, entitled SURGICAL CHARGING SYSTEM THAT CHARGES AND/OR CONDITIONS ONE OR MORE BATTERIES, now U.S. Patent Application Publication No. 2016/0249910;

- U.S. Patent Application Serial No. 14/633,566, entitled CHARGING SYSTEM THAT ENABLES EMERGENCY RESOLUTIONS FOR CHARGING A BATTERY, now U.S. Patent Application Publication No. 2016/0249918;

- U.S. Patent Application Serial No. 14/633,555, entitled SYSTEM FOR MONITORING WHETHER A SURGICAL INSTRUMENT NEEDS TO BE SERVICED, now U.S. Patent Application Publication No. 2016/0249916;

- U.S. Patent Application Serial No. 14/633,542, entitled REINFORCED BATTERY FOR A SURGICAL INSTRUMENT, now U.S. Patent Application Publication No. 2016/0249908;

- U.S. Patent Application Serial No. 14/633,548, entitled POWER ADAPTER FOR A SURGICAL INSTRUMENT, now U.S. Patent Application Publication No. 2016/0249909;

- U.S. Patent Application Serial No. 14/633,526, entitled ADAPTABLE SURGICAL INSTRUMENT HANDLE, now U.S. Patent Application Publication No. 2016/0249945;

- U.S. Patent Application Serial No. 14/633,541, entitled MODULAR STAPLING ASSEMBLY, now U.S. Patent Application Publication No. 2016/0249927; and
- U.S. Patent Application Serial No. 14/633,562, entitled SURGICAL APPARATUS CONFIGURED TO TRACK AN END-OF-LIFE PARAMETER, now U.S. Patent Application Publication No. 2016/0249917.

**[0209]** Applicant of the present application owns the following patent applications that were filed on December 18, 2014 and which are each herein incorporated by reference in their respective entirety:

- U.S. Patent Application Serial No. 14/574,478, entitled SURGICAL INSTRUMENT SYSTEMS COMPRISING AN ARTICULATABLE END EFFECTOR AND MEANS FOR ADJUSTING THE FIRING STROKE OF A FIRING MEMBER, now U.S. Patent No. 9,844,374;
- U.S. Patent Application Serial No. 14/574,483, entitled SURGICAL INSTRUMENT ASSEMBLY COMPRISING LOCKABLE SYSTEMS, now U.S. Patent Application Publication No. 2016/0174969;
- U.S. Patent Application Serial No. 14/575,139, entitled DRIVE ARRANGEMENTS FOR ARTICULATABLE SURGICAL INSTRUMENTS, now U.S. Patent No. 9,844,375;
- U.S. Patent Application Serial No. 14/575,148, entitled LOCKING ARRANGEMENTS FOR DETACHABLE SHAFT ASSEMBLIES WITH ARTICULATABLE SURGICAL END EFFECTORS, now U.S. Patent Application Publication No. 2016/0174976;
- U.S. Patent Application Serial No. 14/575,130, entitled SURGICAL INSTRUMENT WITH AN ANVIL THAT IS SELECTIVELY MOVABLE ABOUT A DISCRETE NON-MOVABLE AXIS RELATIVE TO A STAPLE CARTRIDGE, now U.S. Patent Application Publication No. 2016/0174972;
- U.S. Patent Application Serial No. 14/575,143, entitled SURGICAL INSTRUMENTS WITH IMPROVED CLOSURE ARRANGEMENTS, now U.S. Patent Application Publication No. 2016/0174983;
- U.S. Patent Application Serial No. 14/575,117, entitled SURGICAL INSTRUMENTS WITH ARTICULATABLE END EFFECTORS AND MOVABLE FIRING

BEAM SUPPORT ARRANGEMENTS, now U.S. Patent Application Publication No. 2016/0174975;

- U.S. Patent Application Serial No. 14/575,154, entitled SURGICAL INSTRUMENTS WITH ARTICULATABLE END EFFECTORS AND IMPROVED FIRING BEAM SUPPORT ARRANGEMENTS, now U.S. Patent Application Publication No. 2016/0174973;

- U.S. Patent Application Serial No. 14/574,493, entitled SURGICAL INSTRUMENT ASSEMBLY COMPRISING A FLEXIBLE ARTICULATION SYSTEM, now U.S. Patent Application Publication No. 2016/0174970; and

- U.S. Patent Application Serial No. 14/574,500, entitled SURGICAL INSTRUMENT ASSEMBLY COMPRISING A LOCKABLE ARTICULATION SYSTEM, now U.S. Patent Application Publication No. 2016/0174971.

**[0210]** Applicant of the present application owns the following patent applications that were filed on March 1, 2013 and which are each herein incorporated by reference in their respective entirety:

- U.S. Patent Application Serial No. 13/782,295, entitled ARTICULATABLE SURGICAL INSTRUMENTS WITH CONDUCTIVE PATHWAYS FOR SIGNAL COMMUNICATION, now U.S. Patent No. 9,700,309;

- U.S. Patent Application Serial No. 13/782,323, entitled ROTARY POWERED ARTICULATION JOINTS FOR SURGICAL INSTRUMENTS, now U.S. Patent No. 9,782,169;

- U.S. Patent Application Serial No. 13/782,338, entitled THUMBWHEEL SWITCH ARRANGEMENTS FOR SURGICAL INSTRUMENTS, now U.S. Patent Application Publication No. 2014/0249557;

- U.S. Patent Application Serial No. 13/782,499, entitled ELECTROMECHANICAL SURGICAL DEVICE WITH SIGNAL RELAY ARRANGEMENT, now U.S. Patent No. 9,358,003;

- U.S. Patent Application Serial No. 13/782,460, entitled MULTIPLE PROCESSOR MOTOR CONTROL FOR MODULAR SURGICAL INSTRUMENTS, now U.S. Patent No. 9,554,794;

- U.S. Patent Application Serial No. 13/782,358, entitled JOYSTICK SWITCH ASSEMBLIES FOR SURGICAL INSTRUMENTS, now U.S. Patent No. 9,326,767;
- U.S. Patent Application Serial No. 13/782,481, entitled SENSOR STRAIGHTENED END EFFECTOR DURING REMOVAL THROUGH TROCAR, now U.S. Patent No. 9,468,438;
- U.S. Patent Application Serial No. 13/782,518, entitled CONTROL METHODS FOR SURGICAL INSTRUMENTS WITH REMOVABLE IMPLEMENT PORTIONS, now U.S. Patent Application Publication No. 2014/0246475;
- U.S. Patent Application Serial No. 13/782,375, entitled ROTARY POWERED SURGICAL INSTRUMENTS WITH MULTIPLE DEGREES OF FREEDOM, now U.S. Patent No. 9,398,911; and
- U.S. Patent Application Serial No. 13/782,536, entitled SURGICAL INSTRUMENT SOFT STOP, now U.S. Patent No. 9,307,986.

**[0211]** Applicant of the present application also owns the following patent applications that were filed on March 14, 2013 and which are each herein incorporated by reference in their respective entirety:

- U.S. Patent Application Serial No. 13/803,097, entitled ARTICULATABLE SURGICAL INSTRUMENT COMPRISING A FIRING DRIVE, now U.S. Patent No. 9,687,230;
- U.S. Patent Application Serial No. 13/803,193, entitled CONTROL ARRANGEMENTS FOR A DRIVE MEMBER OF A SURGICAL INSTRUMENT, now U.S. Patent No. 9,332,987;
- U.S. Patent Application Serial No. 13/803,053, entitled INTERCHANGEABLE SHAFT ASSEMBLIES FOR USE WITH A SURGICAL INSTRUMENT, now U.S. Patent Application Publication No. 2014/0263564;
- U.S. Patent Application Serial No. 13/803,086, entitled ARTICULATABLE SURGICAL INSTRUMENT COMPRISING AN ARTICULATION LOCK, now U.S. Patent Application Publication No. 2014/0263541;
- U.S. Patent Application Serial No. 13/803,210, entitled SENSOR ARRANGEMENTS FOR ABSOLUTE POSITIONING SYSTEM FOR SURGICAL INSTRUMENTS, now U.S. Patent No. 9,808,244;

- U.S. Patent Application Serial No. 13/803,148, entitled MULTI-FUNCTION MOTOR FOR A SURGICAL INSTRUMENT, now U.S. Patent Application Publication No. 2014/0263554;
- U.S. Patent Application Serial No. 13/803,066, entitled DRIVE SYSTEM LOCKOUT ARRANGEMENTS FOR MODULAR SURGICAL INSTRUMENTS, now U.S. Patent No. 9,629,623;
- U.S. Patent Application Serial No. 13/803,117, entitled ARTICULATION CONTROL SYSTEM FOR ARTICULATABLE SURGICAL INSTRUMENTS, now U.S. Patent No. 9,351,726;
- U.S. Patent Application Serial No. 13/803,130, entitled DRIVE TRAIN CONTROL ARRANGEMENTS FOR MODULAR SURGICAL INSTRUMENTS, now U.S. Patent No. 9,351,727; and
- U.S. Patent Application Serial No. 13/803,159, entitled METHOD AND SYSTEM FOR OPERATING A SURGICAL INSTRUMENT, now U.S. Patent Application Publication No. 2014/0277017.

**[0212]** Applicant of the present application also owns the following patent application that was filed on March 7, 2014 and is herein incorporated by reference in its entirety:

- U.S. Patent Application Serial No. 14/200,111, entitled CONTROL SYSTEMS FOR SURGICAL INSTRUMENTS, now U.S. Patent No. 9,629,629.

**[0213]** Applicant of the present application also owns the following patent applications that were filed on March 26, 2014 and are each herein incorporated by reference in their respective entirety:

- U.S. Patent Application Serial No. 14/226,106, entitled POWER MANAGEMENT CONTROL SYSTEMS FOR SURGICAL INSTRUMENTS, now U.S. Patent Application Publication No. 2015/0272582;
- U.S. Patent Application Serial No. 14/226,099, entitled STERILIZATION VERIFICATION CIRCUIT, now U.S. Patent No. 9,826,977;
- U.S. Patent Application Serial No. 14/226,094, entitled VERIFICATION OF NUMBER OF BATTERY EXCHANGES/PROCEDURE COUNT, now U.S. Patent Application Publication No. 2015/0272580;

- U.S. Patent Application Serial No. 14/226,117, entitled POWER MANAGEMENT THROUGH SLEEP OPTIONS OF SEGMENTED CIRCUIT AND WAKE UP CONTROL, now U.S. Patent Application Publication No. 2015/0272574;
- U.S. Patent Application Serial No. 14/226,075, entitled MODULAR POWERED SURGICAL INSTRUMENT WITH DETACHABLE SHAFT ASSEMBLIES, now U.S. Patent No. 9,743,929;
- U.S. Patent Application Serial No. 14/226,093, entitled FEEDBACK ALGORITHMS FOR MANUAL BAILOUT SYSTEMS FOR SURGICAL INSTRUMENTS, now U.S. Patent Application Publication No. 2015/0272569;
- U.S. Patent Application Serial No. 14/226,116, entitled SURGICAL INSTRUMENT UTILIZING SENSOR ADAPTATION, now U.S. Patent Application Publication No. 2015/0272571;
- U.S. Patent Application Serial No. 14/226,071, entitled SURGICAL INSTRUMENT CONTROL CIRCUIT HAVING A SAFETY PROCESSOR, now U.S. Patent No. 9,690,362;
- U.S. Patent Application Serial No. 14/226,097, entitled SURGICAL INSTRUMENT COMPRISING INTERACTIVE SYSTEMS, now U.S. Patent No. 9,820,738;
- U.S. Patent Application Serial No. 14/226,126, entitled INTERFACE SYSTEMS FOR USE WITH SURGICAL INSTRUMENTS, now U.S. Patent Application Publication No. 2015/0272572;
- U.S. Patent Application Serial No. 14/226,133, entitled MODULAR SURGICAL INSTRUMENT SYSTEM, now U.S. Patent Application Publication No. 2015/0272557;
- U.S. Patent Application Serial No. 14/226,081, entitled SYSTEMS AND METHODS FOR CONTROLLING A SEGMENTED CIRCUIT, now U.S. Patent No. 9,804,618;
- U.S. Patent Application Serial No. 14/226,076, entitled POWER MANAGEMENT THROUGH SEGMENTED CIRCUIT AND VARIABLE VOLTAGE PROTECTION, now U.S. Patent No. 9,733,663;
- U.S. Patent Application Serial No. 14/226,111, entitled SURGICAL STAPLING INSTRUMENT SYSTEM, now U.S. Patent No. 9,750,499; and

- U.S. Patent Application Serial No. 14/226,125, entitled SURGICAL INSTRUMENT COMPRISING A ROTATABLE SHAFT, now U.S. Patent Application Publication No. 2015/0280384.

**[0214]** Applicant of the present application also owns the following patent applications that were filed on September 5, 2014 and which are each herein incorporated by reference in their respective entirety:

- U.S. Patent Application Serial No. 14/479,103, entitled CIRCUITRY AND SENSORS FOR POWERED MEDICAL DEVICE, now U.S. Patent Application Publication No. 2016/0066912;

- U.S. Patent Application Serial No. 14/479,119, entitled ADJUNCT WITH INTEGRATED SENSORS TO QUANTIFY TISSUE COMPRESSION, now U.S. Patent No. 9,724,094;

- U.S. Patent Application Serial No. 14/478,908, entitled MONITORING DEVICE DEGRADATION BASED ON COMPONENT EVALUATION, now U.S. Patent No. 9,737,301;

- U.S. Patent Application Serial No. 14/478,895, entitled MULTIPLE SENSORS WITH ONE SENSOR AFFECTING A SECOND SENSOR'S OUTPUT OR INTERPRETATION, now U.S. Patent No. 9,757,128;

- U.S. Patent Application Serial No. 14/479,110, entitled POLARITY OF HALL MAGNET TO DETECT MISLOADED CARTRIDGE, now U.S. Patent Application Publication No. 2016/0066915;

- U.S. Patent Application Serial No. 14/479,098, entitled SMART CARTRIDGE WAKE UP OPERATION AND DATA RETENTION, now U.S. Patent Application Publication No. 2016/0066911;

- U.S. Patent Application Serial No. 14/479,115, entitled MULTIPLE MOTOR CONTROL FOR POWERED MEDICAL DEVICE, now U.S. Patent No. 9,788,836; and

- U.S. Patent Application Serial No. 14/479,108, entitled LOCAL DISPLAY OF TISSUE PARAMETER STABILIZATION, now U.S. Patent Application Publication No. 2016/0066913.

**[0215]** Applicant of the present application also owns the following patent applications that were filed on April 9, 2014 and which are each herein incorporated by reference in their respective entirety:

- U.S. Patent Application Serial No. 14/248,590, entitled MOTOR DRIVEN SURGICAL INSTRUMENTS WITH LOCKABLE DUAL DRIVE SHAFTS, now U.S. Patent No. 9,826,976;
- U.S. Patent Application Serial No. 14/248,581, entitled SURGICAL INSTRUMENT COMPRISING A CLOSING DRIVE AND A FIRING DRIVE OPERATED FROM THE SAME ROTATABLE OUTPUT, now U.S. Patent No. 9,649,110;
- U.S. Patent Application Serial No. 14/248,595, entitled SURGICAL INSTRUMENT SHAFT INCLUDING SWITCHES FOR CONTROLLING THE OPERATION OF THE SURGICAL INSTRUMENT, now U.S. Patent No. 9,844,368;
- U.S. Patent Application Serial No. 14/248,588, entitled POWERED LINEAR SURGICAL STAPLE/FASTENER, now U.S. Patent Application Publication No. 2014/0309666;
- U.S. Patent Application Serial No. 14/248,591, entitled TRANSMISSION ARRANGEMENT FOR A SURGICAL INSTRUMENT, now U.S. Patent Application Publication No. 2014/0305991;
- U.S. Patent Application Serial No. 14/248,584, entitled MODULAR MOTOR DRIVEN SURGICAL INSTRUMENTS WITH ALIGNMENT FEATURES FOR ALIGNING ROTARY DRIVE SHAFTS WITH SURGICAL END EFFECTOR SHAFTS, now U.S. Patent No. 9,801,626;
- U.S. Patent Application Serial No. 14/248,587, entitled POWERED SURGICAL STAPLE/FASTENER, now U.S. Patent Application Publication No. 2014/0309665;
- U.S. Patent Application Serial No. 14/248,586, entitled DRIVE SYSTEM DECOUPLING ARRANGEMENT FOR A SURGICAL INSTRUMENT, now U.S. Patent Application Publication No. 2014/0305990; and
- U.S. Patent Application Serial No. 14/248,607, entitled MODULAR MOTOR DRIVEN SURGICAL INSTRUMENTS WITH STATUS INDICATION ARRANGEMENTS, now U.S. Patent No. 9,814,460.

**[0216]** Applicant of the present application also owns the following patent applications that were filed on April 16, 2013 and which are each herein incorporated by reference in their respective entirety:

- U.S. Provisional Patent Application Serial No. 61/812,365, entitled SURGICAL INSTRUMENT WITH MULTIPLE FUNCTIONS PERFORMED BY A SINGLE MOTOR;
- U.S. Provisional Patent Application Serial No. 61/812,376, entitled LINEAR CUTTER WITH POWER;
- U.S. Provisional Patent Application Serial No. 61/812,382, entitled LINEAR CUTTER WITH MOTOR AND PISTOL GRIP;
- U.S. Provisional Patent Application Serial No. 61/812,385, entitled SURGICAL INSTRUMENT HANDLE WITH MULTIPLE ACTUATION MOTORS AND MOTOR CONTROL; and
- U.S. Provisional Patent Application Serial No. 61/812,372, entitled SURGICAL INSTRUMENT WITH MULTIPLE FUNCTIONS PERFORMED BY A SINGLE MOTOR.

**[0217]** Numerous specific details are set forth to provide a thorough understanding of the overall structure, function, manufacture, and use of the embodiments as described in the specification and illustrated in the accompanying drawings. Well-known operations, components, and elements have not been described in detail so as not to obscure the embodiments described in the specification. The reader will understand that the embodiments described and illustrated herein are non-limiting examples, and thus it can be appreciated that the specific structural and functional details disclosed herein may be representative and illustrative. Variations and changes thereto may be made without departing from the scope of the claims.

**[0218]** The terms "comprise" (and any form of comprise, such as "comprises" and "comprising"), "have" (and any form of have, such as "has" and "having"), "include" (and any form of include, such as "includes" and "including"), and "contain" (and any form of contain, such as "contains" and "containing") are open-ended linking verbs. As a result, a surgical system, device, or apparatus that "comprises," "has," "includes," or "contains" one or more elements possesses those one or more elements, but is not limited to possessing only those one or more elements. Likewise, an element of a system, device, or apparatus that "comprises," "has," "includes," or "contains" one or more

features possesses those one or more features, but is not limited to possessing only those one or more features.

**[0219]** The terms “proximal” and “distal” are used herein with reference to a clinician manipulating the handle portion of the surgical instrument. The term “proximal” refers to the portion closest to the clinician and the term “distal” refers to the portion located away from the clinician. It will be further appreciated that, for convenience and clarity, spatial terms such as “vertical”, “horizontal”, “up”, and “down” may be used herein with respect to the drawings. However, surgical instruments are used in many orientations and positions, and these terms are not intended to be limiting and/or absolute.

**[0220]** Various exemplary devices and methods are provided for performing laparoscopic and minimally invasive surgical procedures. However, the reader will readily appreciate that the various methods and devices disclosed herein can be used in numerous surgical procedures and applications including, for example, in connection with open surgical procedures. As the present Detailed Description proceeds, the reader will further appreciate that the various instruments disclosed herein can be inserted into a body in any way, such as through a natural orifice, through an incision or puncture hole formed in tissue, etc. The working portions or end effector portions of the instruments can be inserted directly into a patient’s body or can be inserted through an access device that has a working channel through which the end effector and elongate shaft of a surgical instrument can be advanced.

**[0221]** Various surgical instruments are disclosed herein which are configured to fasten the tissue of a patient. As discussed in greater detail below, such surgical instruments comprise an end effector and a plurality of drive systems configured to perform various end effector functions. Such drive systems can include an anvil drive system configured to clamp the tissue within the end effector, a staple firing system configured to deploy staples into the tissue, and/or a tissue cutting system configured to cut the tissue, for example. Such drive systems can also include an articulation drive system configured to articulate the end effector, a tissue drive system configured to move the end effector relative to the tissue, and/or a staple loading system configured to reload the end effector with staples, for example. As also discussed in greater detail

below, two or more of these drive systems can be operably coupled to a common drive system such that they are operated synchronously.

**[0222]** A stapling instrument 1000 is illustrated in FIG. 1. The stapling instrument 1000 comprises a handle 1100, a shaft assembly 1200 extending from the handle 1100, and an end effector 1300 extending from the shaft assembly 1200. The handle 1100 comprises a frame 1110 and gripping portions 1120 positioned on opposite sides of the frame 1110. The handle 1100 further comprises a plurality of electric motors configured to operate the drive systems of the stapling instrument 1000. Three electric motors 1130, 1140, and 1150 are depicted, but the surgical instrument 1000 can include any suitable number of electric motors. Each electric motor is operably coupled with a rotatable output. For instance, the electric motor 1130 is operably coupled to a rotatable output 1135, the electric motor 1140 is operably coupled to a rotatable output 1145, and the electric motor 1150 is operably coupled to a rotatable output 1155. The handle 1100 further comprises batteries 1160, for example, which supply power to the electric motors 1130, 1140, and 1150. Referring to FIG. 11, the batteries 1160 comprise lithium 18650 batteries, for example, but can comprise any suitable battery. Referring primarily to FIG. 12, the batteries 1160 are positioned in a battery compartment 1115 defined in the handle frame 1110, but can be stored in any suitable location. The batteries 1160 are also configured to supply power to a control system and/or display of the handle 1110, which are described in greater detail below.

**[0223]** A handle 1100' is illustrated in FIGS. 8 and 10. The handle 1100' is similar to the handle 1100 in many respects, most of which will not be discussed herein for the sake of brevity. The handle 1100' comprises a battery compartment which is accessible through a door 1115'. The door 1115' permits the batteries in the battery compartment to be replaced. A handle 1100" is illustrated in FIG. 9. The handle 1100" is similar to the handle 1100 in many respects, most of which will not be discussed herein for the sake of brevity. The handle 1100" comprises a plug 1115" configured to supply power to the handle 1100" from a generator and/or wall outlet, for example. In various instances, the handle 1100" can be powered from an internal source, such as by the batteries 1160, for example, and an external source, such as by the plug 1115", for example.

**[0224]** Referring again to FIG. 1, the handle frame 1110 comprises a connector 1170. The shaft assembly 1200 comprises an outer housing 1210 which includes a shaft connector 1270 configured to be engaged with the handle connector 1170 to couple the shaft assembly 1200 to the handle 1100. The shaft connector 1270 and the handle 1170 comprise a rotatable bayonet interconnection; however, any suitable interconnection could be used. The shaft assembly 1200 further comprises a rotatable input 1235 configured to be operably coupled with the rotatable output 1135 when the shaft assembly 1200 is assembled to the handle 1100. Similarly, the shaft assembly 1200 also comprises a rotatable input 1245 configured to be operably coupled with the rotatable output 1145 and a rotatable input 1255 configured to be operably coupled with the rotatable output 1155 when the shaft assembly 1200 is assembled to the handle 1100.

**[0225]** Further to the above, the outer shaft housing 1210 further comprises a distal connector 1290. The end effector 1300 comprises a shaft portion 1310 which includes an end effector connector 1390 configured to be engaged with the distal connector 1290 to couple the end effector 1300 to the shaft assembly 1200. The end effector connector 1390 and the distal shaft connector 1290 comprise a rotatable interconnection; however, any suitable interconnection could be used. The end effector 1300 further comprises a first drive configured to be operably coupled to the shaft input 1235 when the end effector 1300 is assembled to the shaft assembly 1200. Similarly, the end effector 1300 comprises a second drive configured to be operably coupled to the shaft input 1245 and a third drive configured to be operably coupled to the shaft input 1255 when the end effector 1300 is assembled to the shaft assembly 1200.

**[0226]** In various instances, the shaft assembly 1200 and/or the end effector 1300 comprises one more sensors and/or electrically-driven components. Referring to FIG. 2, the stapling instrument 1000 comprises at least one electrical circuit extending through the handle 1100, the shaft assembly 1200, and the end effector 1300. The electrical circuit comprises conductors in the handle 1100, the shaft assembly 1200, and the end effector 1300 which are placed in electrical communication with one another when the shaft assembly 1200 is assembled to the handle 1100 and the end effector 1300 is assembled to the shaft assembly 1200. FIG. 2 illustrates four conductors 1280

in the shaft assembly 1200 which are part of two separate electrical circuits; however, any suitable number of conductors and/or circuits can be used. The handle connector 1170 and the shaft connector 1270 comprise electrical contacts which are rotated into engagement when the shaft assembly 1200 is rotatably assembled to the handle 1100. Similarly, the distal shaft connector 1290 and the end effector connector 1390 comprise electrical contacts which are rotated into engagement when the end effector 1300 is assembled to the shaft assembly 1200.

**[0227]** Referring again to FIG. 1, the end effector 1300 further comprises a distal head 1320 rotatably connected to the shaft portion 1310 about an articulation joint 1370. The end effector 1300 also comprises an articulation drive system configured to articulate the distal head 1320 relative to the shaft portion 1310. The distal head 1320 comprises an anvil 1360 which is movable between an open position and a closed position. In use, the anvil 1360 is movable toward a tissue compression surface 1325 by an anvil drive system in order to clamp, or compress, tissue within the end effector 1300. As will be discussed in connection with FIGS. 3-7 below, the tissue compression surface 1325 is defined on a tissue drive system which is configured to engage the patient tissue and move the stapling instrument 1000 relative to the patient tissue.

**[0228]** Referring primarily to FIG. 3, the end effector 1300 comprises a rotatable drive shaft 1330 which is usable to selectively open the anvil 1360, operate the tissue drive system (FIGS. 4-6) to re-position the distal head 1320 relative to the patient tissue, and close the anvil 1360 (FIG. 7) before the stapling instrument 1000 performs a staple firing stroke. The drive shaft 1330 is driven by an electric motor and, moreover, the drive shaft 1330 is translatable between a first position in which a key 1332 extending from the drive shaft 1330 is operably engaged with the tissue drive system (FIGS. 4-6) and a second position in which the key 1332 is operably engaged with the anvil drive system (FIG. 7). When the drive shaft 1330 is in its first position, the key 1332 is positioned within a key slot 1333 defined in a drive gear 1331 of the tissue drive system. When the drive shaft 1330 is in its second position, the key 1332 is positioned within a key slot 1363 defined in a drive collar 1361 of the anvil drive system.

**[0229]** Referring to FIGS. 4-6, the tissue drive system comprises a first foot 1380a and a second foot 1380b. The feet 1380a, 1380b are extendable to engage the patient

tissue and then retractable to pull the distal head 1320 of the end effector 1300 relative to the patient tissue. The tissue drive system is configured to extend the first foot 1380a while retracting the second foot 1380b and, similarly, extend the second foot 1380b while retracting the first foot 1380a. FIG. 4 illustrates the first foot 1380a in an extended position and the second foot 1380b in a retracted position. As a result of the above, the tissue drive system can be configured to walk the end effector 1300 across the tissue to create a staple firing path within the tissue. In various alternative embodiments, the tissue drive system can be configured to extend the first foot 1380a and second foot 1380b simultaneously and/or retract the first foot 1380a and second foot 1380b simultaneously.

**[0230]** Further to the above, the tissue drive system comprises a first gear train configured to transfer the rotation of the drive shaft 1330 to the first gear 1380a and a second gear train configured to transfer the rotation of the drive shaft 1330 to the second gear 1380b. The first gear train comprises a spur gear 1381a operably intermeshed with the drive gear 1331, a transfer gear 1382a operably intermeshed with the spur gear 1381a, and a spur gear 1383a operably intermeshed with the transfer gear 1382a such that the rotation of the shaft 1330 is transferred to the spur gear 1383a. The first gear train further comprises a shaft gear 1384a operably intermeshed with the spur gear 1383a. Referring primarily to FIGS. 5 and 6, the shaft gear 1384a is fixedly mounted to a transfer shaft 1385a such that the rotation of the spur gear 1383a is transferred to the transfer shaft 1385a. The first gear train further comprises a bevel gear 1386a fixedly mounted to the transfer shaft 1385a, a side bevel gear 1387a operably intermeshed with the bevel gear 1386a, and a pinion gear 1388a fixedly mounted to the side bevel gear 1387a such that the pinion gear 1388a rotates with the side bevel gear 1387a. Referring primarily to FIG. 6, the pinion gear 1388a is operably intermeshed with a rack 1389a mounted to the first foot 1380a which converts the rotational input motion to translational motion of the first foot 1380a.

**[0231]** The second gear train is similar to the first gear train in many respects except that the second gear train does not include a transfer gear intermediate the two spur gears, as discussed below. The second gear train comprises a spur gear 1381b operably intermeshed with the drive gear 1331 and a spur gear 1383b operably

intermeshed with the spur gear 1381b such that the rotation of the shaft 1330 is transferred to the spur gear 1383b. The second gear train further comprises a shaft gear 1384b operably intermeshed with the spur gear 1383b. Referring primarily to FIG. 5, the shaft gear 1384b is fixedly mounted to a transfer shaft 1385b such that the rotation of the spur gear 1383b is transferred to the transfer shaft 1385b. The second gear train further comprises a bevel gear 1386b fixedly mounted to the transfer shaft 1385b, a side bevel gear 1387b operably intermeshed with the bevel gear 1386b, and a pinion gear 1388b fixedly mounted to the side bevel gear 1387b such that the pinion gear 1388b rotates with the side bevel gear 1387b. The pinion gear 1388b is operably intermeshed with a rack 1389b mounted to the second foot 1380b which converts the rotational input motion to translational motion of the second foot 1380b.

**[0232]** The presence of a transfer gear 1382a in the first gear train and the absence of a corresponding transfer gear in the second gear train cause the first foot 1380a and the second foot 1380b to move in opposite directions in response to the rotation of the drive shaft 1330. For instance, the first foot 1380a is extended and the second foot 1380b is retracted when the drive shaft 1330 is rotated in a first direction. Correspondingly, the first foot 1380a is retracted and the second foot 1380b is extended when the drive shaft 1330 is rotated in a second, or opposite, direction. As discussed above, the first and second feet 1380a, 1380b are configured to grasp and pull the end effector 1300 relative to the tissue as they are extended and retracted. While the motion of the feet 1380a, 1380b may be linear, other embodiments are disclosed herein which provide different motions, such as an arcuate motion, for example.

**[0233]** Once the end effector 1300 has been suitably moved relative to the tissue by the tissue drive system, the drive shaft 1330 is translated longitudinally out of engagement with the tissue drive system and into engagement with the anvil drive system, as illustrated in FIG. 7. In various instances, the rotation of the drive shaft 1330 can be stopped before it is disengaged from the tissue drive system. In other instances, the drive shaft 1330 can continue to rotate as it is disengaged from the tissue drive system and translated into engagement with the drive collar 1361. In either event, the drive collar 1361 comprises a threaded aperture 1362 defined therein including threads 1365. The anvil 1360 comprises a push rod 1364 extending therefrom which includes

an end threadably engaged with the threads 1365 in the aperture 1366. When the drive collar 1361 is rotated in a first direction by the drive shaft 1330, the drive collar 1361 pushes the anvil 1360 away from the feet 1380a and 1380b to open the anvil 1360. Once the anvil 1360 has been sufficiently opened, the drive shaft 1330 can be shifted to engage the tissue drive system and move the end effector 1300 relative to the tissue. The drive shaft 1330 can then be re-engaged with the anvil drive system. When the drive collar 1361 is rotated in a second, or opposite, direction, at such point, the drive collar 1361 pulls the anvil 1360 toward the feet 1380a and 1380b to close or clamp the anvil 1360, as illustrated in FIG. 7. Once the anvil 1360 has been closed, the staple firing system of the stapling instrument 1000 can be actuated. At such point, the anvil 1360 is re-opened by the anvil drive system and the above-described cycle can be repeated.

**[0234]** Notably, the drive shaft 1330 extends along a longitudinal axis 1339 which is collinear with a longitudinal axis 1369 extending through the push rod 1364 of the anvil drive system. Such an arrangement allows the drive shaft 1330 to be operably linked to the push rod 1334 through the drive collar 1361. Also, notably, the drive collar 1361 comprises a proximal flange 1367 and a distal flange 1368 extending therefrom. The flanges 1367 and 1368 act as stops which limit the longitudinal travel of the anvil 1360 in the proximal and distal directions, respectively. As such, the flanges 1367 and 1368 define the limits of the opening and closing strokes of the anvil 1360. The anvil 1360 comprises a tissue clamping face which extends orthogonally, or at least substantially orthogonally, to the longitudinal axis 1369 and moves longitudinally relative to the distal head 1320. The anvil 1360 comprises a movable jaw and the feet 1380a and 1380b of the tissue drive system comprise another movable jaw positioned opposite the anvil 1360.

**[0235]** Referring again to FIG. 3, a longitudinal gap is present between the drive gear 1331 of the tissue drive system and the drive collar 1361 of the anvil drive system. As a result, a dwell in operation may be present when shifting between the tissue drive system and the anvil drive system. A shorter gap can result in shorter dwells while a longer gap can result in longer dwells. Other embodiments are envisioned in which no,

or very little, gap is present between the drive gear 1331 and the drive collar 1361 and, as a result, the operational dwell can be eliminated.

**[0236]** Referring again to FIG. 1, the end effector 1300 comprises a plurality of staple cartridges 1400 stored therein. The stapling instrument 1000 comprises a cartridge drive system configured to push a staple cartridge 1400 into the end effector 1300. As a result, the cartridge drive system can be used to reload the end effector 1300 without having to remove the stapling instrument 1000 from the surgical site. Once the supply of staple cartridges 1400 in the end effector 1300 have been depleted, however, the stapling instrument 1000 may have to be removed from the surgical site to be reloaded unless the stapling instrument 1000 comprises a system for loading cartridges during the operation of the stapling instrument 1000. Such a system is described in greater detail below. In any event, the end effector 1300 can be detached from the shaft assembly 1200 and an unspent end effector 1300 can then be attached to the shaft assembly 1200 to reload the stapling instrument 1000.

**[0237]** Referring again to FIG. 1, each end effector 1300 is intended for as many uses as there are staples or staple cartridges stored in the end effector 1300. The shaft assembly 1200 is intended for more uses than an end effector 1300. As a result, a spent end effector 1300 can be replaced with another end effector 1300 without having to replace the shaft assembly 1200. In at least one instance, each end effector 1300 is intended for 10 uses while the shaft assembly is intended for 100 uses, for example. The handle 1100 is intended for more uses than the shaft assembly 1200 and/or an end effector 1300. As a result, a used shaft assembly 1200 can be replaced without having to replace the handle 1100. In at least one instance, the shaft assembly 1200 is intended for 100 uses while the handle 1100 is intended for 500 uses, for example.

**[0238]** As discussed above, the stapling instrument 1000 comprises a drive system configured to reciprocatingly open, or unclamp, an anvil, create relative motion between the end effector and the patient tissue, and then clamp the anvil once again. FIGS. 42 and 43 illustrate an exemplary embodiment of another reciprocating drive system that could be used. The drive system 2800 comprises a rotatable drive shaft 2830 and a drive gear 2831 fixedly mounted to the drive shaft 2830. The drive system 2800 further comprises a spur gear 2832 operably intermeshed with the drive gear 2831 such that

the rotation of the drive shaft 2830 is transmitted to the spur gear 2832. The drive system 2800 further comprises a bevel gear 2833 that is mounted to and rotates with the spur gear 2832, a side bevel gear 2834 operably intermeshed with the bevel gear 2833, and a spur gear 2835 operably intermeshed with a gear mounted to a face of the bevel gear 2834. The drive system 2800 further comprises a pinion gear 2836 that is fixedly mounted to and rotates with the spur gear 2835, an output gear 2837 operably intermeshed with the pinion gear 2836, and a cam 2838 that is fixedly mounted to and rotates with the output gear 2837. As a result of the above, the rotation of the drive shaft 2830 rotates the cam 2838 which, as described below, is converted to reciprocating motion of the drive shaft 2830.

**[0239]** Further to the above, the drive system 2800 comprises a rotatable shifter 2840 including a cam arm 2848 and a shifter arm 2849 which is rotatable about a pivot 2841. In use, the cam 2838 is configured to engage the cam arm 2848 of the shifter 2840 and rotate the shifter 2840 between a first position (FIG. 43) and a second position (FIG. 42). When the shifter 2840 is rotated into its second position, as illustrated in FIG. 42, the cam arm 2848 engages a shoulder 2839 defined on the drive shaft 2830 and pushes the drive shaft 2830 upwardly. A spring 2820 is positioned between the shoulder 2839 and a frame 2819 of the stapling instrument which is compressed when the drive shaft 2830 is moved into its second position and stores potential energy therein. As the cam 2838 continues to rotate, the cam 2838 disengages from the cam arm 2848 and the spring 2820 resiliently returns the drive shaft 2830 back into its first position, illustrated in FIG. 43. This reciprocating movement of the drive shaft 2830 between its first and second positions can be used to operate a reciprocating drive system in the end effector of the stapling instrument.

**[0240]** FIG. 44 illustrates another exemplary embodiment of a reciprocating drive system. The drive system 2900 comprises an electric motor 2930, a first drive system 2940 operably coupled with the electric motor 2930, and a second drive system 2950 operably coupled with the electric motor 2930. The electric motor 2930 comprises a rotatable output shaft 2931 and a drive gear 2932 fixedly mounted to the output shaft 2931. The first drive system 2940 comprises an input gear 2942 operably intermeshed with the drive gear 2932. The input gear 2942 is fixedly mounted to a drive shaft 2943

such that the drive shaft 2943 rotates with the input gear 2942. The first drive system 2940 further comprises a barrel cam 2944 that is slidably mounted to the drive shaft 2943 and rotates with the drive shaft 2943. The barrel cam 2944 comprises an aperture 2945 defined therein that comprises a non-circular profile, for example, that is configured to transfer rotation between the drive shaft 2943 and the barrel cam 2944, yet permit relative translation therebetween. The barrel cam 2944 further comprises a cam slot 2949 defined therearound which interacts with a cam pin 2919 mounted to a frame 2910 such that, when the barrel cam 2944 is rotated, the barrel cam 2944 is also translated. The barrel cam 2944 is translated distally when the barrel cam 2944 is rotated in a first direction and translated proximally when the barrel cam 2944 is rotated in a second, or opposite, direction. The first drive system 2940 further comprises a drive shaft 2946 extending from the barrel cam 2944 that is configured to drive a first end effector function.

**[0241]** The second drive system 2950 comprises an input gear 2952 operably intermeshed with the drive gear 2932. The input gear 2952 is fixedly mounted to a drive shaft 2953 such that the drive shaft 2953 rotates with the input gear 2952. The second drive system 2950 further comprises a barrel cam 2954 that is slidably mounted to the drive shaft 2953 and rotates with the drive shaft 2953. The barrel cam 2954 comprises an aperture 2955 defined therein that comprises a non-circular profile, for example, that is configured to transfer rotation between the drive shaft 2953 and the barrel cam 2954, yet permit relative translation therebetween. The barrel cam 2954 further comprises a cam slot 2959 defined therearound which interacts with a cam pin 2919 mounted to the frame 2910 such that, when the barrel cam 2954 is rotated, the barrel cam 2944 is also translated. The barrel cam 2954 is translated distally when the barrel cam 2954 is rotated in a first direction and translated proximally when the barrel cam 2954 is rotated in a second, or opposite, direction. The second drive system 2950 further comprises a drive shaft 2956 extending from the barrel cam 2954 that is configured to drive a second end effector function.

**[0242]** When the electric motor 2930 of the drive system 2900 is rotated in a first direction, the first drive shaft 2946 is advanced distally and the second drive shaft 2956 is retracted proximally. Correspondingly, the first drive shaft 2946 is retracted

proximally and the second drive shaft 2956 is advanced distally when the electric motor 2930 is operated in a second, or opposite, direction. Other embodiments are envisioned in which the drive shafts 2946 and 2956 are advanced distally at the same time.

**[0243]** Referring to FIGS. 92 and 93, a stapling instrument 4500 comprises a tissue drive 4590 including a first foot 4580a and a second foot 4580b. The first foot 4580a comprises a rack of teeth 4583a defined thereon, the second foot 4580b comprises a rack of teeth 4583b defined thereon, and the tissue drive 4500 further comprises a pinion gear 4593 meshingly engaged with the racks 4583a and 4583b. The pinion gear 4593 is rotatable back and forth about an axis to reciprocatingly extend and retract the feet 4580a and 4580b and, as a result, drive the stapling instrument relative to the tissue of a patient. The tissue drive 4590 further comprises a first actuator 4592 pinned to the pinion gear 4593 at a pivot joint 4591 and a second actuator 4594 pinned to the pinion gear 4593 at a pivot joint 4595. In use, the first actuator 4592 is pushed and/or the second actuator 4594 is pulled to rotate the pinion gear 4593 in a first direction, extend the second foot 4580b, and retract the first foot 4580a. Correspondingly, the first actuator 4592 is pulled and/or the second actuator 4594 is pushed to rotate the pinion gear 4593 in a second direction, extend the first foot 4580a, and retract the second foot 4580b. Notably, the feet 4580a and 4580b are displaced linearly and in opposite directions. That said, the feet 4580a and 4580b are configured such that, when one of the feet 4580a and 4580b is being retracted to pull the tissue, the other foot slides, or slips, relative to the tissue as it is extended.

**[0244]** As discussed above, the feet 1380a and 1380b of the stapling instrument 1000 are extended and retracted along linear paths. In such instances, the feet 1380a and 1380b may slide over the tissue as they are being extended and then grab and pull the tissue as they are being retracted. The feet 1380a and 1380b can comprise teeth extending therefrom which have profiles which facilitate the feet 1380a and 1380b to slide relative to the tissue when moved in one direction and grab the tissue when moved in the opposite direction. In at least one instance, the teeth are substantially triangular, for example, but comprise a shallow angle on a first side and a steeper angle on the other side. In such instances, the shallow angle permits the first side to slide relative to

the tissue, whereas the steeper angle on the second side bites or grabs the tissue when the feet 1380a and 1380b are retracted.

**[0245]** As discussed above, the feet 1380a and 1380b are driven along a linear path by the racks 1389a and 1389b defined thereon. In some instances, the linear motion of the feet 1380a and 1380b can be tightly guided with little, if any, float or deviation from the linear motion. In various embodiments, referring now to FIGS. 88 and 89, the feet of a tissue drive system can comprise one or more joints which provide at least one additional degree of freedom which allows the feet to deviate from a purely linear path. The tissue drive system 4200 comprises a first foot 4280a and a second foot 4280b which are movably connected by a link 4282. The link 4282 is coupled to the first foot 4280a at a pivot joint 4281a and the second foot 4280b at a pivot joint 4281b. The feet 4280a and 4280b are moved proximally and distally by an input 4290 which includes a drive shaft 4292 connected to the link 4282 at a pivot joint 4283. The pivot joints 4281a, 4281b, and 4283 allow the feet 4280a and 4280b to lift or float upwardly when extended across the tissue.

**[0246]** As discussed above, the stapling instruments disclosed herein comprising a tissue drive system are configured to drive, or march, themselves across the tissue of a patient as they staple and cut the patient tissue along a staple firing path. In various instances, the thickness of the tissue can change along the length of the staple firing path. Stated another way, the tissue can increase and/or decrease in thickness in a forward-to-back direction and/or a lateral side-to-side direction. Referring again to FIGS. 88 and 89, the degrees of freedom provided by the pivot joints 4281a, 4281b, and 4283 allow the feet 4280a and 4280b to tilt in response to these changes in tissue thickness. For instance, the feet 4280a and 4280b can tilt in a forward-to-back direction and/or in a side-to-side direction. Moreover, the feet 4280a and 4280b can tilt independently of one another. As such, the feet 4280a and 4280b can tilt in the same direction or in different directions. That said, alternative embodiments are envisioned in which the feet 4280a and 4280b tilt in the same direction. Such an arrangement could have a simpler drive system. In any event, the feet 4280a and 4280b can self-level in response to changes in tissue thickness and can have a desired traction on the tissue.

**[0247]** Referring now to FIG. 87, a stapling instrument 4100 comprises a distal stapling head 4120 which, similar to the stapling instrument 1000, comprises a tissue drive system 4190 including feet 4180. The tissue drive system 4190 comprises a rocker link 4192 rotatably mounted within the stapling head 4120 about a pivot pin 4124. The rocker link 4192 comprises legs 4193 and the pivot pin 4124 extends through apertures 4194 defined in the legs 4193. Each of the legs 4193 is pivotably connected to a foot 4180 about a pivot pin 4195. In use, the tissue drive system 4190 rocks the rocker link 4192 back and forth to extend and retract the feet 4180 along a non-linear, or curved, path. The feet 4180 are extended and retracted together, although embodiments are envisioned in which they are moved in opposite directions. Moreover, further to the above, the feet 4180 can tilt about the pivot pins 4195 in order to adapt to changes in tissue thickness. In various instances, the tissue drive system 4190 can lift the feet 4180 away from the tissue for at least part of the tissue drive stroke, such as at the end of the tissue drive stroke, for example.

**[0248]** Referring now to FIGS. 37-41, a surgical instrument 2700 comprises a distal head 2720 including an anvil 2760, a tissue drive foot 2780, and a tissue drive 2790. The tissue drive 2790 comprises a positioning rod 2791 attached to the drive foot 2780 at a pivot joint 2781. The positioning rod 2791 is displaceable along a longitudinal axis to engage (FIG. 38) and disengage (FIG. 41) the drive foot 2780 from the patient tissue T. When the drive foot 2780 is disengaged from the tissue and withdrawn into the distal head 2720, referring to FIG. 37, a distal tip 2785 of the drive foot 2780 is positioned within, and does not extend from, the distal head 2720. Moreover, the drive foot 2780 is locked in position, or prevented from being rotated, when the drive foot 2780 is withdrawn into the distal head 2720. More specifically, the distal head 2720 comprises a control slot 2724 defined therein and the foot 2780 comprises two control pins 2784 slidably positioned in the control slot 2724 which are configured to prevent the drive foot 2780 from rotating when the drive foot 2780 is in its withdrawn position (FIGS. 37 and 41) and to permit the drive foot 2780 to rotate when the drive foot 2780 is in its engaged position (FIGS. 38-40), which is discussed below.

**[0249]** Referring to FIGS. 38-40, the drive foot 2780 is configured to engage the patient tissue T and drive the distal head 2720 relative to the tissue in order to re-

position the distal head 2720 relative to the tissue. The tissue drive 2790 comprises a first driver 2792 and a second driver 2793 configured to rotate the foot 2780 about the pivot joint 2781. The first driver 2792 comprises a push end positioned within a first socket 2782 defined in the drive foot 2780 and the second driver 2793 comprises a push end positioned within a second socket 2783 defined on the opposite side of the drive foot 2780. Referring to FIG. 40, the first driver 2792 is displaceable toward the tissue to rotate the drive foot 2780 in a first direction. Referring to FIG. 39, the second driver 2793 is displaceable toward the tissue to rotate the drive foot in a second, or opposite, direction. In use, the drive foot 2780 is rotatable back and forth by the tissue drive 2790 to create relative motion between the distal head 2720 and the tissue in the forward or backward directions.

**[0250]** Referring now to FIGS. 78-85, a stapling instrument 3900 comprises a distal head 3920 which includes, a staple firing system 3950 configured to staple the tissue of a patient, an anvil 3960 configured to clamp the patient tissue against a tissue compression surface 3925 and deform the staples deployed by the staple firing system 3950, and feet 3980 configured to generate relative movement between the distal head 3920 and the tissue when the anvil 3960 is in an unclamped position. The stapling instrument 3900 further comprises a tissue drive 3990 configured to extend and retract the feet 3980. Referring primarily to FIGS. 83 and 84, the tissue drive 3990 comprises a rotatable drive shaft 3992 and a worm gear 3993 fixedly mounted to the drive shaft 3992 such that the worm gear 3993 rotates with the drive shaft 3992. The worm gear 3993 is meshingly engaged with a gear face 3995 defined on one side of a drive wheel 3994. The drive wheel 3994 is rotatably mounted about a pin 3991 which is mounted to the distal head 3920. As a result of the above, the drive wheel 3994 rotates in response to the rotation of the drive shaft 3992.

**[0251]** Further to the above, referring to FIGS. 79-82, the tissue drive 3990 further comprises a coupler bar 3996 comprising a first end slidably positioned in a cam slot 3999 (FIGS. 83 and 85) defined in a second side, or face, of the drive wheel 3994. In at least one instance, the coupler bar 3996 comprises a pin that rides in the cam slot 3999. The coupler bar 3996 further comprises a second end pivotably mounted to the feet 3980 at pivot joints 3998. When the drive wheel 3994 is rotated, the sidewalls of the

cam slot 3999 push the first end of the coupler bar 3996 through a path, or motion, indicated in FIG. 84. This path is also illustrated in FIGS. 79A, 80A, 81A, and 82A which track the motion of the tissue drive 3990 and the feet 3980 depicted in FIGS. 79, 80, 81, and 82, respectively. FIG. 79 illustrates the feet 3980 in a retracted position and FIG. 79A shows a dot P on the foot motion path FM that represents the position of the feet 3980 along the foot motion path FM. FIG. 80 illustrates the feet 3980 being extended and FIG. 80A shows the dot P advanced along the foot motion path FM. FIG. 81 illustrates the feet 3980 in a fully-extended position and the dot P advanced further along the foot motion path FM. FIG. 82 illustrates the feet 3980 returned to their retracted position. At such point, the motion of the feet 3980 can be repeated, or reciprocated.

**[0252]** Further to the above, the coupler bar 3996 comprises a longitudinal slot 3997 defined therein and the staple head 3920 comprises a pin 3927 extending into the longitudinal slot 3997 which co-operate to limit or constrain the motion of the coupler bar 3996. FIGS. 84 and 85 map three corresponding positions, labeled 1, 2, and 3, along the cam slot 3999 and the firing motion path FM. The position 1 corresponds to the point P in FIG. 79A, the position 2 corresponds to the point P in FIG. 80A, and the position 3 corresponds to point P in FIG. 81A. In various instances, the tissue drive 3990 comprises a four-bar linkage in which the feet 3980 are lofted when then they are extended. In order to facilitate this motion, each foot 3980 comprises a slot 3981 defined therein, the sidewalls of which slide relative to a pin 3921 extending into the slot 3981. The pin 3921/slot 3981 arrangements permit the feet 3980 to translate and rotate during the tissue drive stroke cycle.

**[0253]** FIG. 86 illustrates an alternative embodiment of a cam path 4099 which comprises shoulders which prevent back motion of the coupler bar 3996 within the slot 3999. For instance, the cam path 4099 comprises a first shoulder 4091 which corresponds to the position 1 and FIG. 79A and, once the coupler bar 3996 has passed this point, the coupler bar 3996 cannot backtrack past the position 1. The cam path 4099 comprises a second shoulder 4092 which corresponds to the position 2 and FIG. 80A and, once the coupler bar 3996 has passed this point, the coupler bar 3996 cannot backtrack past the position 2. The cam 4099 also comprises a third shoulder 4093

which corresponds to the position 3 and FIG. 81A and, once the coupler bar 3996 has passed this point, the coupler bar 3996 cannot backtrack past the position 3.

**[0254]** Referring to FIGS. 50-56, a stapling instrument 3100 comprises a distal head 3120 including an anvil 3160 and tissue drive feet 3180. Referring to FIG. 50, the drive feet 3180 are extendable to engage the tissue of a patient and then, referring to FIG. 51, retractable to move the distal head 3120 relative to the patient tissue. Each drive foot 3180 comprises a rack, or an array, of teeth 3193 configured to engage the patient tissue which is also movable between extended and retracted positions. FIG. 51 illustrates that the teeth 3193 extend from the drive feet 3180 when the drive feet 3180 are being retracted from an extended position. More specifically, the teeth 3193 protrude from tissue compression surfaces 3125 defined on the drive feet 3180 when the drive feet 3180 are being retracted from their fully-extended position. On the other hand, referring to FIG. 50, the teeth 3193 do not protrude from the tissue compression surfaces 3125 as the drive feet 3180 are being extended which allows the drive feet 3180 to slide relative to the patient tissue while being extended.

**[0255]** Referring to FIGS. 52-56, the stapling instrument 3100 comprises a tissue drive 3190 configured to extend and retract the drive feet 3180 and, also, extend and retract the teeth 3193. The tissue drive 3190 comprises an input bar 3191 that extends into, and is movable within, a cavity 3181 defined in each drive foot 3180. The input bar 3191 moves the drive feet 3180 through a circuitous, non-linear path which includes a raised, retracted position (FIGS. 52 and 56), a lowered, retracted position (FIG. 53), a lowered, extended position (FIG. 54), and a raised, extended position (FIG. 55). The input bar 3191 comprises pins 3192 extending therefrom which extend into slots 3182 defined in the drive feet 3180. As discussed in greater detail below, the interaction between the pins 3192 and the sidewalls of the slots 3182 transfers the motion of the input bar 3191 to the drive feet 3180. Each of the slots 3182 extend along an axis which is transverse to and non-parallel to a longitudinal axis of the distal head 3120 which, as a result, creates the desired motion of the drive feet 3180 and teeth 3193.

**[0256]** When the input bar 3191 is in a fully-retracted position, as illustrated in FIG. 52, the input bar 3191 positions the drive feet 3180 in their raised, retracted position. In this position, the teeth 3193 protrude through windows 3183 defined in the drive feet

3180. As the input bar 3191 is moved out of its fully-retracted position, referring to FIG. 53, the pins 3192 interact with the sidewalls of the slots 3182 and cam the drive feet 3180 downwardly. At such point, the teeth 3193 no longer protrude through the windows 3183. As the input bar 3191 is moved further away from its fully-retracted position, the input bar 3191 begins to extend the drive feet 3180 as illustrated in FIG. 54. Notably, the teeth 3193 do not protrude through the windows 3183 as the drive feet 3180 are being extended. However, once the input bar 3191 is retracted, as illustrated in FIG. 55, the pins 3192 interact with the sidewalls of the slots 3182 to raise the drive feet 3180 which causes the teeth 3193 to protrude through the windows 3183. As a result, the teeth 3193 can engage or grab the patient tissue and pull the tissue relative to the distal head 3120 until the drive feet 3180 are fully retracted, as illustrated in FIG. 56. At such point, the tissue can be stapled and/or incised. The above-described process can be repeated to move the stapling instrument 3100 along an entire staple firing path.

**[0257]** Referring to FIGS. 57-59D, a stapling instrument 3200 comprises a distal stapling head 3220 including tissue drive feet 3270 which are extended outwardly and retracted inwardly along the same path by a tissue drive system, such as the tissue drive system of the stapling instrument 1000, for example. That said, the stapling head 3220 further comprises lateral drive feet 3280 which move with the drive feet 3270 but can also move laterally relative to the drive feet 3270, as illustrated in FIGS. 57 and 58. As a result, the lateral drive feet 3280 can be extended along one path, as illustrated in FIGS. 59A and 59B, extended laterally, and then retracted along a different path, as illustrated in FIGS. 59C and 59D. Moreover, the drive feet 3270 and 3280 can pull the distal head 3220 relative to the patient tissue in two different directions, which provides greater control over the relative movement between the distal stapling head 3220 and the patient tissue.

**[0258]** Referring primarily to FIGS. 57 and 58, the drive feet 3270 and 3280 are rotatably coupled in pairs. Each pair comprises an actuator plate 3260, a first link 3272 pivotably coupled to the drive foot 3270 about a pivot 3271, and a second link 3282 pivotably coupled to the lateral drive foot 3280 about a pivot 3281. When a downward force is applied to the actuator plate 3260, referring to FIG. 58, the actuator plate 3260

pushes on a joint 3213 rotatably connecting the first link 3272 and the second link 3282, which causes the lateral foot 3280 to displace outwardly. Moreover, the distal head 3220 constrains the lateral movement of the drive foot 3270 and, as a result, the drive foot 3270 does not move laterally when the lateral drive foot 3280 is extended laterally. However, referring to FIGS. 60A-60D, alternative embodiments are envisioned in which the drive foot 3270 can also move laterally. In either event, a biasing member, such as a torsion spring positioned in and/or coupled to the joint 3213, for example, can retract the drive feet laterally after the pushing force is removed from the actuator plate 3260. FIGS. 59A-59D depict a sequence of steps that can be repeated by the surgical instrument 3200 to move the stapling instrument 3200 along a staple firing path. FIGS. 60A-60D also depict a sequence of steps that can be repeated by the surgical instrument 3200 to move the stapling instrument 3200 along a staple firing path.

**[0259]** Referring to FIGS. 61 and 62, a surgical instrument 3300 comprises a distal head 3320 and laterally-extendable drive feet 3380. The drive feet 3380 are coupled to distal head 3320 via flexible connectors 3375 and actuators 3370. When a compressive force is applied to an actuator 3370, the actuator 3370 is displaced and/or compressed which causes the connectors 3375 to extend laterally and push the corresponding drive foot 3380 laterally. When the compressive force is removed from the actuator 3370, the connectors 3375 resiliently contract and pull the drive foot 3380 inwardly. The drive feet 3380 can include tissue gripping features defined thereon which are configured to push and/or pull the patient tissue when the drive feet 3380 are being moved laterally. As a result, the drive feet 3380 can create relative movement between the distal head 3320 and the patient tissue.

**[0260]** Referring to FIGS. 91A-91D, a stapling instrument 4400 comprises a distal head 4420 which includes a tissue cutting drive 4440, a staple firing drive 4450, and a tissue drive including feet 4480. Each foot 4480 is rotatably mounted to the distal head 4420 about a pivot pin 4481 and is rotatable to drive the distal head 4420 relative to the patient tissue. FIG. 91 illustrates the feet 4480 in a retracted position. FIG. 91B illustrates the feet 4480 being extended. FIG. 91C illustrates the feet 4480 in their fully-extended position. FIG. 91D illustrates the feet 4480 being retracted. When the feet 4480 are extended, the feet 4480 drive the distal head 4420 relative to the patient

tissue. Notably, the feet 4480 are synchronized such that they are extended and retracted together and, in such instances, the feet 4480 can drive the distal head 4420 along a straight, or at least substantially straight, line. That said, one of the feet 4480 can be extended while the other foot 4480 is retracted. In such instances, the feet 4480 can turn the distal head 4420 along a curved path.

**[0261]** Referring to FIGS. 76 and 77A-77D, a stapling instrument 3800 comprises a distal head 3820 including a staple firing system 3850, an anvil 3860, and a tissue drive system. The tissue drive system comprises a first foot 3880a and a second foot 3880b and is configured to selectively extend and retract the feet 3880a and 3880b to move the stapling instrument 3800 along a staple firing path FP. The tissue drive system is configured to move, or march, the stapling instrument 3800 along straight and/or curved staple firing paths. Referring to FIGS. 77A and 77B, the tissue drive system is configured to simultaneously extend and retract the first foot 3880a and the second foot 3880b an equal, or an at least nearly equal, amount to move the distal firing head 3220 along a straight firing path. Referring to FIGS. 77C and 77D, the tissue drive system is also configured to extend and retract only one of the feet 3880a and 3880b to turn the distal firing head 3220. For instance, referring to FIG. 77C, the tissue drive system can extend and retract the first foot 3880a, while not extending and retracting the second foot 3880b, to turn the distal head 3820 in a first direction. Similarly, referring to FIG. 77D, the tissue drive system can extend and retract the second foot 3880b, while not extending and retracting the first foot 3880a, to turn the distal head 3820 in a second direction.

**[0262]** As discussed above, the tissue drive system is configured to turn the distal head 3820 of the stapling instrument 3800 by operating one of the feet 3880a and 3880b, but not the other. Alternatively, the tissue drive system can be configured to turn the distal head 3820 by extending one of the feet 3880a and 3880b less than the other. The distal head 3820 could be gradually turned in such instances. The tissue drive system can also be configured to turn the distal head 3820 by moving the feet 3880a and 3880b in opposite directions. In such instances, the distal head 3820 could follow small, or tight, radiuses of curvature in the staple firing path FP.

**[0263]** Referring to FIGS. 63 and 64, a stapling instrument 3400 comprises a distal head 3420 including a staple firing system 3450, an anvil 3460, and a tissue drive system. The tissue drive system comprises two drive wheels 3480 and a shaft 3481, which is rotatably supported by mounts 3482, extending through apertures defined in the center of the drive wheels 3480. The drive wheels 3480 are fixedly mounted to the pin 3481 such that the drive wheels 3480 rotate together. Each drive wheel 3480 comprises an array of teeth extending therearound and at least one of the drive wheels 3480 is meshingly engaged with a drive shaft of an electric motor. The teeth extending around the drive wheels 3480 are also suitably configured to engage and grip the patient tissue. In use, the electric motor can be operated to turn the drive wheels 3480 to create relative movement between the distal head 3420 and the patient tissue and move the distal head 3420 along a staple firing path.

**[0264]** Referring to FIG. 94, a stapling instrument 4600 comprises a distal head 4620 including a staple firing system 4650, an anvil 4660, and a tissue drive system. The tissue drive system comprises drive two drive wheels 4680 which are each rotatably supported by a separate pin extending through the center thereof. As a result, the drive wheels 4680 can be rotated independently. Each drive wheel 4680 comprises an array of teeth extending therearound which is meshingly engaged with a drive shaft of an electric motor. Stated another way, the tissue drive system comprises two electric motors which are configured to rotate the drive wheels 4680 separately. Similar to the above, the teeth extending around the drive wheels 4680 are also suitably configured to engage and grip the patient tissue. In use, the electric motors can be operated to turn the drive wheels 4680 to create relative movement between the distal head 4620 and the patient tissue and move the distal head 4620 along a staple firing path, as described in greater detail below.

**[0265]** Further to the above, the tissue drive system is configured to rotate the drive wheels 4680 in the same direction at the same speed to move the distal head 4620 along a straight staple firing path. The tissue drive system is also configured to rotate the wheels 4680 in the same direction, but at different speeds, to turn the distal head 4620 along a curved staple firing path. The distal head 4620 can make gradual turns in such instances. The tissue drive system is also configured to turn only one of the drive

wheels 4680, while not turning the other drive wheel 4680, to turn the distal head 4620 along a curved staple firing path. Moreover, the tissue drive system is further configured to rotate the drive wheels 4680 in opposite directions to turn the distal head 4620 along curved staple firing paths having a small, or tight, radius of curvature.

**[0266]** The tissue drive system further comprises lateral drive wheels 4670 which are positioned laterally with respect to the drive wheels 4680. Similar to the above, each lateral drive wheel 4670 is operably coupled to a different electric motor. As a result, the tissue drive system of the stapling instrument 4600 comprises four electric motors which are operable at the same time or at different times. The lateral drive wheels 4670 are operable independently of the drive wheels 4680, although they could be operated at the same time as one or both of the drive wheels 4680. Moreover, the lateral drive wheels 4670 are operable independently with respect to each other. Similar to the drive wheels 4680, the tissue drive system is configured to turn the lateral drive wheels 4670 together at the same speed, at different speeds, and/or in different directions to move the distal head 4620 along a staple firing path. Moreover, the tissue drive system is configured to turn any suitable combination of the drive wheels 4670 and 4680 in any suitable direction and at any suitable speed to move the stapling instrument 4600 along a desired staple firing path.

**[0267]** Referring to FIG. 36, a stapling instrument 2600 comprises a distal head 2620 including a staple firing system 2650, an anvil 2660, and a tissue drive system. The tissue drive system comprises two drive wheels 2670 and two drive wheels 2680 which can be rotated independently, at the same time or at different times, to move the distal head 2620 along a staple firing path. Each drive wheel 2670 is rotatable about an axis 2671 and each drive wheel 2680 is rotatable about an axis 2681; however, the axes 2671 are not parallel to the axes 2681. In fact, the axes 2671 and 2681 are orthogonal, but can be oriented in any suitable direction. The tissue drive system comprises four electric motors which are configured to rotate the drive wheels 2670 and 2680 separately; however, the tissue drive system can have any suitable number of electric motors to drive the drive wheels 2670 and 2680. In use, the electric motors can be operated to turn the drive wheels 2670 and 2680 to create relative movement between

the distal head 2620 and the patient tissue and move the distal head 2620 along a staple firing path.

**[0268]** Referring now to FIGS. 75A-75D, a stapling instrument 3700 comprises a distal head 3720 including an anvil 3760 and a tissue drive system including a tissue drive foot 3780. The stapling instrument 3700 is similar to the stapling instrument 1000 in many respects, most of which will not be discussed herein for the sake of brevity. The anvil 3760 is movable relative to the foot 3780 between a closed, or clamped, position (FIGS. 75A and 75D) and an open, or unclamped, position (FIGS. 75B and 75C). While the anvil 3760 is being opened, referring to FIG. 75B, the drive foot 3780 can be extended to engage and grip tissue. Referring to FIG. 75C, the drive foot 3780 is then retracted to create relative motion between the distal head 3720 and the patient tissue. Referring to FIG. 75D, the anvil 3760 is movable toward its closed position while the drive foot 3780 is being retracted and/or after the drive foot 3780 has been retracted. The drive foot 3780 can have teeth which grips the tissue and/or any suitable means for gripping and pulling the tissue. In various instances, the drive foot 3780 is configured to apply a vacuum to the tissue in order to grip and pull the tissue. In at least one such instance, the vacuum system is off during the operational steps depicted in FIGS. 75A and 75B and on during the operational steps depicted in FIGS. 75C and 75D, for example. In such instances, the vacuum can also hold the tissue in the distal head 3720 as the anvil 3760 is being closed, although other embodiments are envisioned in which the vacuum is off during the operation step depicted in FIG. 75D.

**[0269]** Referring now to FIGS. 65-69, a stapling instrument 3500 comprises a distal head 3520 including an anvil 3560 and a tissue drive system including a vacuum supply line 3570, two vacuum graspers 3580, and two grasper extenders 3590. The vacuum supply line 3570 comprises a manifold 3571 configured to deliver a vacuum pressure differential to the two grasper extenders 3590 and the two vacuum graspers 3580. Each grasper extender 3590 comprises a bellows 3591 in communication with the manifold 3571 which contracts and extends when a vacuum is communicated to the inner plenum of the bellows 3591. When the bellows 3591 contract, they extend the graspers 3580 to the position illustrated in FIG. 65. Each bellows 3591 is in fluid communication with a cavity 3581 defined in a grasper 3580 which allows a vacuum

pressure differential to be communicated to grasper holes 3582 defined in a tissue engaging surface 3585 of the grasper 3580. This vacuum pressure differential at the grasper holes 3582 can hold the patient tissue against the tissue engaging surface 3585.

**[0270]** As discussed above, the extension of the graspers 3580 graspers corresponds with the application of a vacuum pressure differential to the tissue. When the vacuum supply line 3570 no longer supplies a vacuum pressure differential to the bellows 3591, the bellows 3591 will resiliently re-expand and contract and, correspondingly, retract the graspers 3580, as illustrated in FIG. 67. Similarly, the bellows 3591 may also re-expand and retract the graspers 3580 when the vacuum pressure differential is reduced. In either event, the vacuum pressure differential at the grasper holes 3582 may lessen as the graspers 3580 are being retracted. In some instances, the remaining vacuum pressure differential at the grasper holes 3582 may be sufficient to pull the patient tissue into a tissue chamber 3525 in the distal head 3520. In other instances, the remaining vacuum pressure differential at the grasper holes 3582, alone, may not be sufficient to pull the patient tissue into the tissue chamber 3525. With this in mind, the graspers 3580 comprise flexible teeth 3586 extending from the tissue engaging surfaces 3585 thereof. When the graspers 3580 are being extended, referring to FIG. 66, the flexible teeth 3586 slide over the patient tissue without snagging, or at least significantly snagging, on the patient tissue. This relative movement is also facilitated by the transverse angle in which the teeth 3586 extend from the tissue engaging surface 3585. When the graspers 3580 are being retracted, referring to FIG. 68, the teeth 3586 bite into the patient tissue and pull the patient tissue into the tissue chamber 3525. Again, this is facilitated by the angle of the teeth 3586 and can compensate for a loss of vacuum pressure differential at the grasper holes 3582.

**[0271]** Once the patient tissue is positioned in the tissue chamber 3525, the tissue can be stapled and/or incised. The supply line 3570 does not supply a vacuum pressure differential during the stapling and/or cutting operations as doing so may extend the graspers 3580 and move the tissue. That said, the vacuum supply could be turned on during the stapling and/or cutting operations if there was, for example, another way to hold the tissue in place. In either event, the anvil 3560 can thereafter be

re-opened, the distal head 3520 can be moved relative to the tissue, and the vacuum supply can be used to re-extend the tissue graspers 3580 so that the above-described process can be repeated, as illustrated in FIG. 69.

**[0272]** Referring to FIGS. 70-73, a stapling instrument 3600 comprises a distal stapling head 3620 including a staple firing system 3650, an anvil 3660, a tissue cutting system 3640 and, also, a tissue grasping system that utilizes vacuum pressure differentials. The stapling instrument 3600 is similar to the stapling instrument 3500 in many respects, most of which will not be discussed herein for the sake of brevity. That said, the tissue grasping system comprises two separate and distinct vacuum supply lines - a first supply line 3670a in communication with a first bellows 3690a which is in fluid communication with a first tissue drive foot 3680a via a foot manifold 3685a and, also, a second supply line 3670b in communication with a second bellows 3690b which is in fluid communication with a second tissue drive foot 3680b via a foot manifold 3685b. The foot manifold 3685a comprises an array of manifold apertures 3686 which are in communication with foot apertures 3682 defined in the first foot 3680a and communicate a vacuum pressure differential to the foot apertures 3682 when a vacuum is supplied to the first supply line 3670a. The foot manifold 3685b comprises an array of manifold apertures 3686 which are in communication with foot apertures 3682 defined in the second foot 3680b and communicate a vacuum pressure differential to the foot apertures 3682 when a vacuum is supplied to the second supply line 3670b. The stapling instrument 3600 further comprises a control system configured to selectively apply a vacuum to the first supply line 3670a and the second supply line 3670b such that the first drive foot 3680a and the second drive foot 3680b can be selectively extended and retracted. In some instances, the feet 3680a and 3680b are synchronized and simultaneously extended and retracted together while, in other instances, the feet 3680a and 3680b are extended and retracted at different times.

**[0273]** An alternative embodiment of a stapling instrument 3600' is illustrated in FIG. 74. The stapling instrument 3600' is similar to the stapling instrument 3600 in many respects. That said, the instrument 3600' comprises larger tissue drive feet 3680' that have more vacuum holes 3682 defined therein as compared to the tissue drive feet 3680 of the stapling instrument 3600.

**[0274]** Referring now to FIGS. 47A-47G, a stapling instrument 3000 comprises a distal head 3020 including a staple firing system, an anvil closure system including an anvil 3060, a tissue drive including at least one drive foot 3080, and a tissue gripper 3070 configured to releasably hold the tissue. Referring to FIG. 47A, the anvil 3060 is movable from a clamped position to an unclamped position to unclamp the patient tissue T. Referring to FIG. 47B, the tissue gripper 3070 is engageable with the patient tissue T to hold the tissue in place while the drive foot 3080 is extended, which is illustrated in FIGS. 47C and 47D. The tissue gripper 3070 can be engaged with the tissue as the anvil 3060 is being opened and/or after the anvil 3060 has been opened. In either event, referring to FIG. 47E, the tissue gripper 3070 is disengaged from the tissue before the drive foot 3080 is retracted to pull the distal head 3020 relative to the tissue and position the distal head 3020 at a new position along the staple firing path, as illustrated in FIG. 47F. At such point, referring to FIG. 47G, the patient tissue is clamped by the anvil 3060 and the staple firing system is operated to staple the tissue. At such point, the above-described cycle can be repeated.

**[0275]** As illustrated in FIGS. 47D-47F, the drive foot 3080 is in fluid communication with a vacuum source 3090. Similar to the above, the drive foot 3080 can utilize a vacuum pressure differential from the vacuum source 3090 to grip the patient tissue. Also similar to the above, the vacuum pressure differential from the vacuum source 3090 can be used to extend the drive foot 3080. That said, the drive foot 3080 can be extended using any suitable mechanism.

**[0276]** Referring again to FIG. 78, the stapling instrument 3900 further comprises tissue grippers 3970. The tissue grippers 3970 are useable in conjunction with the drive feet 3980 in the same, or a similar manner, that the tissue grippers 3070 are used in conjunction with the drive foot 3080.

**[0277]** FIGS. 45, 46, 48, and 49 depict the operational sequencing of a stapling instrument which could be used with a stapling instrument disclosed herein, such as a stapling instrument 4000 and/or the stapling instrument 3900 discussed above, for example. The stapling instrument 4000 is similar to the other stapling instruments disclosed herein in many respects, most of which will not be discussed herein for the sake of brevity. The stapling instrument 4000 comprises an anvil drive system 4060, a

staple firing system 4050, a tissue cutting system 4040, a tissue gripping system 4090, and a tissue drive system 4080 configured to move the stapling instrument 4000 relative to the patient tissue. FIG. 49 depicts the operational steps of the stapling instrument 4000, which occur in the order presented. For instance, step 4003 follows step 4002 and step 4002 follows step 4001, and so forth. That said, it should be understood that adjacent operational steps can occur simultaneously, or with at least some amount of overlap, as illustrated in FIG. 46 and discussed in greater detail below. Moreover, the operational steps of FIG. 49 can be re-arranged in any suitable order.

**[0278]** Referring again to FIG. 49, the operational step 4001 comprises loading a staple cartridge into the stapling instrument 4000 and/or pushing a staple cartridge into position within the stapling instrument 4000. The operational step 4002 comprises removing staples from the staple cartridge and the operational step 4003 comprises placing the staples in position within the staple firing drive 4050. The operational step 4004 comprises articulating the end effector of the stapling instrument 4000, if needed. That said, the operational step 4004 can also occur before and/or during the steps 4001, 4002, and/or 4003. The operational step 4005 comprises positioning the end effector on the patient tissue and the operational step 4006 comprises operating the anvil drive system 4060 to clamp the anvil on the tissue. The operational step 4005 can also occur before the operational step 4004.

**[0279]** Further to the above, the operational step 4007 comprises forming the staples against the anvil and the operational step 4008 comprises deploying the knife of the tissue cutting system 4040. The operational step 4007 occurs before the operational step 4008, but the steps 4007 and 4008 could occur at the same time or with some amount of overlap. The operational step 4009 comprises using the tissue cutting system 4040 to retract the knife and it follows the operational step 4008. The operational step 4010 comprises gripping and holding the patient tissue positioned within the end effector of the stapling instrument 4000 using the tissue gripping system 4090. The operational step 4011 comprises unclamping the anvil using the anvil drive system 4060. In such instances, the stapling instrument 4000 can hold the tissue even though the anvil is open as a result of the tissue gripping system. The operational step 4012 comprises advancing the feet of the tissue drive system 4080. The operational

step 4013 comprises actuating the tissue gripping system 4090 to ungrasp the tissue and the operational step 4014 comprises retracting the feet of the tissue drive system 4080 and advancing the stapling instrument 4000 relative to the tissue.

**[0280]** Further to the above, FIG. 46 illustrates that certain operational steps can occur at the same time or with some amount of overlap. For instance, the step 4011 of opening the anvil and the step 4001 of loading a staple cartridge into position can occur at the same time or with at least some overlap. Similarly, the step of 4002 and/or 4003 comprising advancing staples into position within the staple firing drive 4050 can occur at the same time as, or with some overlap with, the step 4011 of opening the anvil, the step 4010 of gripping the tissue with the tissue gripping system 4090, the step 4012 of extending the feet of the tissue drive system 4080, the step 4013 of releasing the tissue with the gripping system 4090, and/or the step 4014 of retracting the feet of the tissue drive system 4080, for example. Moreover, the step 4001 of reloading another staple cartridge into position within the stapling instrument 4000 can occur at the same time, or with some overlap with, the step 4008 of cutting the tissue and/or the step 4009 of retracting the tissue cutting knife.

**[0281]** Further to the above, FIG. 45 illustrates the actuation cycles of the anvil drive system 4060 and the tissue drive system 4080 of the stapling instrument 4000. The actuation cycles in FIG. 45 are plotted with respect to time  $t$ , wherein the 0, or zero, demarcations on the horizontal time axes represent the beginning of a cycle sequence of the stapling instrument 4000. Referring to the actuation cycle of the anvil drive system 4060, the peak 4006 correlates with the step 4006, discussed above, which comprises closing, or clamping, the anvil onto tissue. Similarly, the dwell 4011 correlates with the step 4011, discussed above, which comprises opening, or unclamping, the tissue. Referring now to the actuation cycle of the tissue drive system 4080, the peak 4012 correlates with the step 4012 which comprises extending the feet of the tissue drive system 4080 and the peak 4014 correlates with the step 4014 which comprises retracting the feet of the tissue drive system 4080 and driving the stapling instrument 4000 relative to the patient tissue. Upon comparing the actuation cycles for the anvil drive system 4060 and the tissue drive system 4080, it can be seen that the anvil is open, or is being opened, when the feet are being extended. Moreover, it can

be seen that the anvil is open when the feet are being retracted and that the anvil is closed at the beginning of the next cycle of the stapling instrument 4000.

**[0282]** As discussed above, it can be desirable to perform certain operational steps of the stapling instrument 4000 sequentially and other operational steps at the same time. In some instances, however, it may not be desirable to perform certain operational steps at the time. As such, the stapling instrument 4000 is configured to lockout certain drive systems and prevent them from being operated while other drive systems of the stapling instrument 4000 are being operated. Lockouts can include mechanical lockouts and/or electrical lockouts, for example. All of the drive systems of the stapling instrument 4000 are motorized and in communication with the controller of the stapling instrument 4000 and, as such, the controller can be used to lockout the drive systems. The controller comprises a microprocessor, for example, which is configured to electronically lockout one or more drive systems during the operation of one or more other drive systems. FIG. 48 is a chart which illustrates which operational steps are prevented from being performed during the performance of other operational steps. For instance, during the step 4001 in which a staple cartridge is loaded into position, all of the other operational steps are locked out, or prevented from happening, other than the step 4004 which articulates the end effector of the stapling instrument 4000, the step 4005 which positions the stapling instrument 4000 relative to the tissue, and the step 4011 which unclamps the anvil. In this example, the staple firing system 4050, the tissue drive system 4080, and the tissue gripping system 4090 are locked out. This is just one example. Other steps could be unlocked during the step 4001 if it was determined that doing so was not detrimental, or unacceptably detrimental, to the operation of the stapling instrument 4000.

**[0283]** Referring to FIGS. 90A-90D, a stapling instrument 4300 comprises a distal head 4320 including a staple firing system 4350, an anvil drive system including an anvil 4360, and a tissue cutting system 4340. The stapling instrument 4300 is similar to the stapling instrument 1000 and stapling instrument 4400 in many respects, most of which will not be discussed herein for the sake of brevity. The stapling instrument 4300 further comprises upper feet 4370a and 4370b and lower feet 4380a and 4380b. Similar to the feet 4480 of the stapling instrument 4400, the feet 4370a, 4370b, 4380a, and 4380b are

rotatable between extended (FIG. 90A) and retracted (FIGS. 90B-D) positions to move the distal head 4320 relative to the patient tissue T. Referring to FIG. 90A, the feet 4370a and 4380a comprise a first synchronized pair of feet that move together and grab the patient tissue when they are moved into their extended position. In such instances, the feet 4370a and 4380a are moved toward one another to apply a compressive force or pressure to the tissue. When the feet 4370a and 4380a are retracted, referring to FIG. 90B, the feet 4370a and 4380a pull on the tissue to move the distal head 4320 relative to the tissue. Once the feet 4370a and 4380a have been retracted, referring to FIG. 90C, the staple firing system 4350 and tissue cutting system 4340 staple and cut the patient tissue. The staple firing system 4350 and tissue cutting system 4340 are operated simultaneously; however, the staple firing system 4350 could be operated before the tissue cutting system 4340. That said, cutting the tissue before stapling it may result in unnecessary bleeding. Notably, though, the feet 4370a and feet 4380a apply a clamping pressure to the tissue while the stapling instrument 4300 staples and cuts the tissue. Once the tissue has been stapled and incised, referring to FIG. 90D, the feet 4370a and 4380a are moved away from the tissue to unclamp the tissue.

**[0284]** As discussed above, the feet 4370a and 4380a are operably coupled together such that they move together as a pair. They rotate together as a pair, they clamp together as a pair, and they unclamp together as a pair. Various alternative embodiments are envisioned in which only one of the feet 4370a and 4380a moves to clamp and unclamp the tissue; however, the feet 4370a and 4380a would still rotate together as a pair. A second synchronized pair of feet including feet 4370b and 4380b move in the same manner as the first synchronized pair of feet including feet 4370a and 4380a and, as such, a discussion of their motion will not be repeated for the sake of brevity. That said, the motion of the first pair of feet is synchronized with the motion of the second pair of feet. More specifically, the second pair of feet are extended at the same time that the first pair of feet are extended, the second pair of feet are clamped to grip the tissue at the same time that the first pair of feet are clamped, the second pair of feet are retracted at the same time that the first pair of feet are retracted, and the second pair of feet are unclamped at the same time that the first pair of feet are unclamped. In certain instances, the motion of the first pair of feet and the second pair

of feet are not synchronized, or entirely synchronized. In at least one such instance, the first pair of feet is extended and retracted independently of the second pair of feet to turn the distal head 4320 along a curved staple path.

**[0285]** As discussed above, the stapling instruments disclosed herein are configured to staple the tissue of a patient. They are also configured to cut the tissue. Referring to FIGS. 95 and 96, a stapling instrument 5000 comprises a distal head 5020 including a staple firing system, a tissue cutting system 5040, and an anvil 5060 configured to deform the staples deployed by the staple firing system. The tissue cutting system 5040 comprises a knife bar 5042 which includes a knife edge 5045 defined at the distal end 5044 thereof. In use, the knife bar 5042 is translatable laterally through the distal head 5020 during a tissue cutting stroke. The tissue cutting stroke of the knife bar 5042 extends between a first, unactuated position, illustrated in FIG. 95, and a second, actuated, position. During the tissue cutting stroke, the knife edge 5045 extends between a tissue compression surface 5025 and a tissue compression surface 5065 defined on the anvil 5060. The knife edge 5045 can also extend into the distal head 5020 and/or the anvil 5060 during the tissue cutting stroke to assure that the entire thickness of the tissue is transected.

**[0286]** Further to the above, the distal head 5020 defines a longitudinal head axis HA. During the tissue cutting stroke, the knife bar 5042 moves orthogonally relative to the longitudinal head axis HA. The tissue cutting system 5400 further comprises a cutting actuator 5046 configured to engage the knife bar 5042 and displace the knife bar 5042 laterally. The cutting actuator 5046 comprises a distal end 5047 which includes an angled cam surface configured to engage a corresponding cam surface 5043 defined on the distal end 5044 of the knife bar 5042. The cutting actuator 5046 can also be configured to push the knife bar 5042 in any suitable manner. In other embodiments, the knife bar 5042 can be moved without a cutting actuator 5046.

**[0287]** Referring to FIG. 98, a stapling instrument 5100 comprises a distal head 5120 including a staple forming anvil 5160. The stapling instrument 5100 further comprises a staple feeding system 5190, a staple alignment system 5180, and a staple firing system 5150. The staple firing system 5150 comprises staple drivers 5151 which are movable longitudinally to eject a set, or cluster, of staples 5130 from the distal head 5120 during

a staple firing stroke. Referring to FIGS. 99 and 100, each staple 5130 comprises a base 5131 and staple legs 5132 extending from the base 5131. Referring to FIGS. 100 and 101, the staple drivers 5151 are configured to push on the bases 5131 of the staples 5130 to push the staple legs 5132 against forming pockets 5162 (FIG. 97) defined in the anvil 5160 during staple firing stroke. At such point, referring to FIG. 102, the staple drivers 5151 are returned to the starting, or unfired, point of the staple firing stroke so that another staple firing stroke can be performed.

**[0288]** As described above, the stapling instrument 5100 is configured to deploy staples during each staple firing stroke. Referring to FIG. 103, the stapling instrument 5100 further comprises a tissue cutting knife 5140 configured to cut the tissue during and/or after each staple firing stroke. The staple firing system 5150 is configured to deploy a first group, or cluster, of three staples 5130 positioned on a first side of a cutting path CP created by the knife 5140 and a second group, or cluster, of three staples 5130 positioned on a second side of the cutting path CP. The staple firing system 5150 deploys the first and second staple groups at the same time; however, embodiments are envisioned in which the first group is deployed before the second staple group. Alternative embodiments are envisioned in which a stapling instrument does not comprise a tissue cutting system, or the tissue cutting system of the stapling instrument can be deactivated. The staple feeding system 5190 and the staple alignment system 5180 co-operate to reposition another set of staples 5130 in the distal head 5120 after each staple firing stroke is performed so that another staple firing stroke can be performed. In various instances, the staples 5130 are reloaded during the tissue cutting stroke and/or after the tissue cutting stroke.

**[0289]** Referring primarily to FIGS. 97, 100, and 102, the staple feeding system 5190 comprises staple pushers 5191. Each staple pusher 5191 is configured to push a staple 5130 into a staple cavity 5121 defined in the distal head 5120. Further to the above, the distal head 5120 comprises six staple cavities 5121 which are each configured to receive a staple 5130 from the staple feeding system 5190. The staples 5130 are arranged in six stacks, or columns, which are aligned with the staple cavities 5121. The staple pushers 5191 push on the bases 5131 of the proximal-most staples 5130 in each staple stack in order to push the distal-most staples 5130 of each staple

stack into the staple cavities 5121 during a pushing stroke. The staple pushers 5191 load staples 5130 into the staple cavities 5121 at the same time, i.e., during a common pushing stroke; however, in alternative embodiments, the staple pushers 5191 can be configured to sequentially load the staples 5130 into the staple cavities 5121. Referring to FIGS. 98 and 99, the staples 5130 within a staple stack are releasably attached to one another by at least one adhesive 5135, for example. As illustrated in FIG. 100, the staples 5130 of each staple stack are adhered to one another at angle which is transverse to a firing axis FA of a staple firing system driver 5151. The distal head 5120 comprises cam surfaces 5122 which orient and align the staples 5130 with the firing axes FA of the staple firing system drivers 5151 before the staple firing stroke of the staple firing system 5150 is performed.

**[0290]** The staple drivers 5151 and the staple pushers 5191 move parallel, or at least substantially parallel, to one another. Owing to the design of the staple drivers 5151 and the staple pushers 5191, and/or other space constraints, referring to FIGS. 97 and 103, the stapling instrument 5100 further includes a staple alignment system comprising staple pushers 5180 which are configured to work with the staple pushers 5191 to align the staples 5130 with the staple drivers 5151. The staple pushers 5191 push the staples 5130 longitudinally and the staple pushers 5180 push the staples 5130 laterally.

**[0291]** Referring to FIGS. 104-105D, a stapling instrument 5200 comprises a distal head 5220 including a staple firing system 5250 configured to deploy staples 5230, a tissue cutting system, and an anvil 5260 including forming pockets configured to deform the staples 5230. The staple firing system 5250 comprises rotatable actuators 5252 configured to displace lateral staple drivers 5254 along linear, or at least substantially linear, lateral paths. Each rotatable actuator 5252 comprises a cam 5253 configured to engage a shoulder 5255 defined on the staple drivers 5254 and displace the drivers 5254 laterally, as illustrated in FIG. 105B. The staple firing system 5250 further comprises one or more springs 5224 positioned intermediate the lateral staple drivers 5254 and a frame 5222 of the distal head 5220. The springs 5224 are compressed as the staple drivers 5254 are slid laterally by the rotatable actuators 5252 until the cams 5253 disengage from the shoulders 5255 of the drivers 5254 during the continued rotation of the actuators 5252, as illustrated in FIG. 105C. At such point, referring to

FIG. 105D, the springs 5224 resiliently return the lateral staple drivers 5254 back into their unactuated positions.

**[0292]** Referring to FIGS. 104 and 105A, the staple firing drive 5250 further comprises longitudinal staple drivers 5257 which are driven along longitudinal staple firing paths by the lateral staple drivers 5254. Each lateral staple driver 5254 comprises a drive cavity 5256 defined therein which receives a portion of a longitudinal staple driver 5257 therein. More specifically, each longitudinal staple driver 5257 comprises a cam portion positioned in a drive cavity 5256 which is driven longitudinally, as illustrated in FIG. 105B, by a cam surface 5258 defined in the drive cavity 5256 when the lateral staple drivers 5254 are move laterally. As a result of the above, the rotational movement of the rotatable actuators 5252 is converted to the lateral translation of the lateral staple drivers 5254, which is converted to the longitudinal translation of the longitudinal staple drivers 5257. The longitudinal motion of the of staple drivers 5257 drives the staples 5230 against the anvil 5260 to deform the staples 5230, as illustrated in FIG. 105B. The longitudinal staple drivers 5257 comprise staple cradles 5251 defined therein which are configured to support the staples 5230 as the staples 5230 are being deformed.

**[0293]** Further to the above, referring to FIG. 105C, the return lateral motion of the staple drivers 5254 withdraws the longitudinal staple drivers 5257 back into their unactuated positions. More specifically, the drive cavities 5256 further comprise a cam surface 5258' configured to drive the longitudinal staple drivers 5257 in an opposite direction until the staple drivers 5257 are reset in their unactuated, or unfired, positions, as illustrated in FIG. 105D. Notably, the anvil 5260 is moved into an open position when the longitudinal staple drivers 5257 are retracted. At such point, the distal head 5220 can be moved relative to the tissue, staples 5230 can be reloaded into the distal head 5220, and the anvil 5260 can be re-clamped onto the tissue, as illustrated in FIG. 105A wherein another staple firing stroke of the staple firing drive 5250 can be performed.

**[0294]** As described above, columns of connected staples can be used to supply, and re-supply, the staple firing system of a stapling instrument. In other instances, entire staple cartridges can be used to supply, and re-supply, a staple firing system. Referring to FIG. 106, a stapling instrument 5300 comprises a shaft 5310, a distal head 5320, and

an articulation joint 5370 rotatably connecting the distal head 5320 to the shaft 5310. The stapling instrument 5300 further comprises a plurality of staple cartridges 5330" stored in the shaft 5310 and a cartridge pusher system configured to push the staple cartridges 5330" into the distal head 5320. Once a staple cartridge 5330" is positioned in the distal head 5320, the staples 5330 (FIG. 107) contained in the staple cartridge 5330" can be separated and deployed by a staple firing system, as discussed in greater detail below. In various instances, the staple cartridge comprises a cartridge body which is broken up and deployed with the staples, while in other instances, the staples are ejected from the cartridge body and the cartridge body is not implanted.

**[0295]** Further to the above, referring to FIG. 107, the staple cartridge 5330" comprises a cartridge body 5333 including an aperture defined therein. The aperture includes a first side 5334 configured to receive and store a first group of staples 5330 and a second side 5335 configured to receive and store a second group of staples 5330. The first group of staples 5330 is deployed on a first side of a tissue incision path created by a tissue cutting knife and the second group of staples 5330 is deployed on a second side of the tissue incision path. The staples 5330 are further arranged in clusters 5330' of three staples which are deployed together, although staple clusters can include any suitable number of staples. Five staple clusters 5330' are stored in the first side 5334 of the cartridge body 5333 and five staple clusters 5330' are stored in the second side 5335 of the cartridge body 5333, although any suitable number of clusters could be used. A staple cluster 5330' is ejected from each side 5334 and 5335 of the cartridge body 5333 and deformed against an anvil 5360 during each staple firing stroke of the stapling system. In various alternative embodiments, the staple clusters 5330' can be sequentially deployed from the first and second sides 5334 and 5335.

**[0296]** Further to the above, the staples 5330 of each staple cluster 5330' are attached to one another by at least one adhesive; however, the staple clusters 5330' themselves are not attached to one another and are, instead, stored side-by-side in the cartridge body 5333. In at least one alternative embodiment, the staples of adjacent staple clusters are releasably attached to one another. Referring now to FIG. 108, the cartridge body 5333, for example, can be configured to releasably store a plurality of staple clusters 5430' therein wherein each staple cluster 5430' comprises three staples.

The three staples 5430 of each staple cluster 5430' are attached to one another by at least one adhesive 5435 and, also, the staple clusters 5430' are attached to one another by at least one adhesive 5435. In such embodiments, the staple clusters 5430' are attached to one another to form a staple strip 5430", wherein one or more staple clusters 5430' are detached from the other staple clusters 5430' to load the distal head 5320 with staples. Although the staple clusters of the embodiments described above comprise three staples, a staple cluster can include any suitable number of staples including two staples, for example, or more than three staples.

**[0297]** Referring to FIGS. 109 and 110, a stapling instrument 5400 comprises a shaft 5410, a distal head, a staple loading system, a staple firing system, a tissue cutting system, an anvil closure system, and a system configured to move the distal head relative to the tissue of a patient. The stapling instrument 5400 further comprises the staple strip 5430" of FIG. 108 stored in the shaft 5410. The staple strip 5430" can be stored within the cartridge body 5333, as described above, or it can be stored within the shaft 5410 without the cartridge body. The staple strip 5430" can comprise any suitable number of staples and/or staple clusters. In at least one instance, the staple strip 5430" comprises 588 staples, for example.

**[0298]** Referring to FIGS. 111 and 112, a stapling instrument 5500 comprises a shaft 5510, a distal head, a staple loading system, a staple firing system, a tissue cutting system, an anvil closure system, and a system configured to move the distal head relative to the tissue of a patient. The stapling instrument 5500 further comprises a first staple strip 5530a" and a second staple strip 5530b" stored in the shaft 5510. The staple strips 5530a" and 5530b" are comprised of staples 5430 which are arranged in staple clusters 5430'. The staple strips 5530a" and 5530b" are nested such that the bases of the staples 5430 face in opposite directions.

**[0299]** Referring to FIGS. 113 and 114, a stapling instrument 5600 comprises a shaft 5610, a distal head, a staple loading system, a staple firing system, a tissue cutting system, an anvil closure system, and a system configured to move the distal head relative to the tissue of a patient. The stapling instrument 5600 further comprises a first staple strip 5630a" and a second staple strip 5630b" stored in the shaft 5610. The staple strips 5630a" and 5630b" are comprised of staples 5430 which are arranged in

staple clusters 5430'. The staple strips 5630a" and 5630b" are arranged in a side-by-side manner such that the bases of the staples 5430 face the same direction.

**[0300]** Referring again to FIG. 106, the stapling instrument 5300 comprises a system for pushing a staple cartridge 5330" from the shaft 5310 into the distal head 5320. Notably, this cartridge pushing system pushes the staple cartridges 5330" through the articulation joint 5370 into the distal head 5320. As a result, the size of the staple cartridges 5330", and/or staples 5330, may be limited by the space constraints of the articulation joint 5370, especially when the distal head 5320 is articulated. FIGS. 115-118 disclose a stapling instrument 5700 comprising flexible staple strips which can feed staples into a distal head through an articulation joint. The stapling instrument 5700 includes a first staple strip 5730' comprising staples 5730 attached to a first carrier 5760'. More specifically, the staples 5730 are attached to the first carrier 5760' at tabs 5761'. Each staple 5730 comprises a base 5731 and legs 5732 extending therefrom, wherein the base 5731 is connected to the first staple strip 5730' by a tab 5761'. The stapling instrument 5700 further includes a second staple strip 5730" comprising staples 5730 attached to a second carrier 5760" at tabs 5761". The carriers 5760' and 5760" each comprise an array of apertures 5762 which, as described in greater detail below, are used to feed the staple strips 5730' and 5730" into the distal head of the stapling instrument 5700.

**[0301]** The staple strip 5730' is stored in a shaft of the stapling instrument 5700. In its stored state, the staple strip 5730' is planar, or at least substantially planar. More specifically, referring to FIGS. 115 and 116, the staples 5730 are attached to the first carrier 5760' such that they lie in-plane with the first carrier 5760'. The stapling instrument 5700 further comprises a staple feeding system including a drive wheel which is configured to push the staple strip 5730' in the distal head of the stapling instrument 5700. The drive wheel comprises an array of drive pins extending therearound which are configured to engage the apertures 5762 of the first carrier 5760' and drive the first carrier 5760' into the distal head. The second staple strip 5730" is also stored in the shaft of the stapling instrument 5700. In its stored state, the staple strip 5730" is planar, or at least substantially planar. More specifically, referring to FIGS. 115 and 116, the staples 5730 are attached to the second carrier 5760" such that

they lie in-plane with the second carrier 5760". Similar to the above, a drive wheel of the staple feeding system is configured to engage the apertures 5762 of the second carrier 5760" and drive the second carrier 5760" into the distal head of the stapling instrument 5700.

**[0302]** Referring to FIGS. 115 and 118, the staple strips 5730' and 5730" are stored in a face-to-face arrangement such that the carriers 5760' and 5760" of the staple strips 5730' and 5730" can be engaged and driven on opposite sides by the staple feeding system. As the staple strips 5730' and 5730" are being fed into the distal head, referring to FIG. 116, the staples 5730 are bent downwardly about the tabs 5761' and 5761" of the staple strips 5730' and 5730", respectively. In at least one instance, the frame of the distal head comprises cam surfaces configured to bend the staples 5730 downwardly. In certain instances, the stapling instrument 5700 comprises one or more actuators configured to bend the staples 5730 downwardly about a mandrel positioned under the tabs 5761' and 5761", for example. Once displaced into their downward positions, the staples 5730 are detached from the staple strips 5730' and 5730". In at least one instance, the frame of the distal head comprises one or more shear surfaces, or knife edges, configured to separate the staples 5730 from the tabs 5761' and 5761" as the staple strips 5730' and 5730" are advanced into the distal head. In certain instances, the stapling instrument 5700 further comprises one or more shears that are actuated to separate the staples 5730 from the staple strips 5730' and 5730". In either event, the separated staples are then positioned to be deployed by the staple firing system of the stapling instrument 5700.

**[0303]** Further to the above, the stapling instrument 5700 is configured to separate a cluster of staples from the staple strips 5730' and 5730" and then advance the carriers 5760' and 5760" of the staple strips 5730' and 5730" so that another cluster of staples can be separated from the staple strips 5730' and 5730". Once the staples 5730 have been separated from the carriers 5760' and 5760", referring to FIG. 118, the empty, or stripped, portions of the carriers 5760' and 5760" are fed back into the shaft of the stapling instrument 5700. As a result, the motion which feeds new staples 5730 into the staple firing system also feeds the empty carriers 5760' and 5760" back into the shaft.

**[0304]** Referring to FIG. 119, a staple cluster 5830' comprises four staples 5830 which are adhered together by at least one adhesive 5835. Each staple 5830 comprises a base 5831 and two staple legs 5832 extending from the base 5831. Notably, the legs 5832 are not co-planar with the base 5831. Rather, the base 5831 is present in a base plane and the legs 5832 are present in a leg plane. The base plane is parallel, or at least substantially parallel, to the leg plane, although embodiments are envisioned in which the base plane and the leg plane are not parallel. In either event, two of the staples 5830 of the staple cluster 5830' face inwardly while two of the staples 5830 face outwardly. A staple 5830 faces outwardly when its base plane is closer to the center of the staple cluster 5830' than its leg plane. Correspondingly, a staple 5830 faces inwardly when its leg plane is closer to the center of the staple cluster 5830' than its base plane.

**[0305]** Further to the above, the staple cluster 5830' comprises two staples 5830 located on a first side of a centerline CL and two staples 5830 located on a second side of the centerline CL. The staples 5830 on the first side of the staple cluster 5830' are connected by a first adhesive connector 5835 and the staples 5830 on the second side of the staple cluster 5830' are connected by a second adhesive connector 5835. Moreover, a staple 5830 on the first side of the staple cluster 5830' is connected to a staple 5830 on the second side of the staple cluster 5830' by an adhesive connector 5835. That said, a staple cluster can comprise any suitable number of adhesive connectors. The adhesive connectors 5835 releasably hold the staples 5830 together. The adhesive connectors 5835 are broken before the staples 5830 are implanted into the patient tissue; however, alternative embodiments are envisioned in which the adhesive connectors 5835 are not broken before the staples 5830 are implanted into the patient tissue. The adhesive connectors 5835 are comprised of biocompatible and/or bioabsorbable materials, such as bioabsorbable polymers, for example.

**[0306]** Referring to FIG. 120, a stapling instrument 5900 comprises a shaft, a distal head 5920, a staple feeding system, a staple firing system, a tissue cutting system, an anvil closing system, and a drive system configured to move the distal head 5920 relative to the patient tissue. The distal head 5920 comprises a first staple cavity 5921 and a second staple cavity 5921. Each staple cavity 5921 is configured to store a

staple cluster 5930', or a column of staple clusters 5930', therein. Each staple cluster 5930' comprises four staples 5930, although it can include any suitable number of staples. Each staple 5930 comprises a base 5931 and two staple legs 5932 extending therefrom. The base 5931 and the legs 5932 are co-planar, or at least substantially co-planar. The staples 5930 are releasably connected to one another by at least one adhesive.

**[0307]** Further to the above, each staple cluster 5930' comprises one or more guides 5935. The guides 5935 are defined on the lateral sides of the cluster 5930' and are configured to be received within notches 5925 defined in the staple cavities 5921. More specifically, the guides 5935 are closely received by the sidewalls of the notches 5925 such that there is little, if any, relative lateral movement between the clusters 5930' and the distal head 5920. To this end, the staple clusters 5930' remain aligned with the forming pockets of the anvil as the staples 5930 are deployed. The guides 5935 are comprised of a biocompatible and/or bioabsorbable material, such as a bioabsorbable polymer, for example, and are implantable with the staples 5930.

**[0308]** Referring to FIG. 121, a stapling instrument 6000 comprises, among other things, a shaft, a distal head 6020 including an anvil 6060, and a staple firing system. In this embodiment, the staple firing system loads staples 6030 into the distal head 6020 and fires them by pushing them against the anvil 6060. The distal head 6020 comprises staple cavities 6021 defined therein which are configured to store and guide the staples 6030 as they are being pushed toward the anvil 6060.

**[0309]** Referring to FIGS. 122-125, a stapling instrument 6100 comprises a shaft, a distal head 6120, a staple loading system, a staple firing system, an anvil drive system, a tissue gripping system, and a tissue drive system configured to move the distal head 6120 relative to the patient tissue. The drive system of the stapling instrument 6100 comprises rotatable feet 6180 which, similar to the above, are configured to grip the tissue of a patient and pull the distal head 6120 relative to the tissue. Also similar to the above, the tissue gripping system is configured to hold the tissue as the feet 6180 are being extended and/or during any suitable time during the operation of the surgical instrument 6100. Referring primarily to FIG. 125, the tissue gripping system comprises a tissue holder 6170 configured to engage the tissue of a patient. The tissue holder

6170 comprises a rectangular body 6172 and stems 6174 extending from the body 6172. The tissue holder 6170 defines a tissue engaging surface 6175 which is smaller than the cross-sectional thickness 6125 of the distal head 6120, which is illustrated in FIG. 124. Owing to the smaller area of the tissue engaging surface 6175 as compared to the cross-sectional thickness 6125, the tissue holder 6170 can apply a larger gripping pressure to the patient tissue than the distal head 6120 could for a given clamping force. In at least one instance, the tissue engaging surface 6175 has an area which is about 25% of the cross-sectional thickness 6125.

**[0310]** Referring to FIGS. 126-137, a stapling instrument 6200 comprises a shaft, a distal head 6220, a staple firing system 6250, a tissue cutting system, an anvil drive system, and a tissue drive system configured to move the distal head 6220 relative to the tissue of a patient. Referring to FIGS. 126 and 127, the tissue drive system comprises rotatable feet 6280 which are moved into an extended position (FIG. 126) and then retracted (FIG. 127) to grip the patient tissue and move the distal head 6220 relative to the tissue. FIG. 128A also illustrates one of the feet 6280 in its extended position. The feet 6280 can be extended and then retracted at the same time to move the distal head 6220 along a straight path or extended and retracted separately to turn the distal head 6220, but only one foot 6280 is shown in FIG. 128A for the purpose of illustration. FIG. 128, which corresponds to FIG. 128A, depicts the anvil 6260 in a sufficiently-clamped state so that the anvil 6260 and the feet 6280 co-operate to grip the patient tissue. Moreover, FIG. 128 depicts an unformed staple 6230 positioned in a staple cavity 6221 defined in the distal head 6220 and the staple firing system 6250 in an unfired state.

**[0311]** FIG. 129A, similar to FIG. 127, depicts the feet 6280 in their retracted position. FIG. 129, which corresponds to FIG. 129A, depicts the anvil 6260 in a fully-clamped state and the staple firing system 6250 in a fired state. As illustrated in FIG. 129, the legs 6232 of the staple 6230 have been fully deformed into a B-shaped configuration; however, other deformed configurations of the staple 6230 may be suitable. Referring now to FIGS. 131 and 133, the staple firing system 6250 comprises a firing bar 6255 and a plurality of staples 6230 stored within recesses 6252 defined in the sides of the firing bar 6255. A first column of staples 6230 is stored in a first side of the firing bar

6255 and a second column of staples 6230 is stored in a second, or opposite, side of the firing bar 6255. Each of the recesses 6252 is defined by a proximal staple cradle 6251 configured to push on the base 6231 of the staple 6230 positioned therein. FIG. 134 depicts two staples 6230 positioned in a staple cavity 6221 defined in the distal head 6220 and the firing bar 6255 of the staple firing system 6250 in an unfired state.

**[0312]** Referring again to FIG. 134, the sides of the staple cavity 6221 comprises recesses 6222 defined therein. The sides of the staple cavity 6221 also comprise drag surfaces 6223 positioned intermediate the recesses 6222. When the firing bar 6255 is pushed distally to fire a first group of staples 6230 positioned in the staple cavity 6221 during a first staple firing stroke, the staples 6230 stored in the firing bar 6255 are pushed by the drag surfaces 6223. As the firing bar 6255 is retracted after the first firing stroke, referring to FIG. 136, the staples 6230 catch on the drag surfaces 6223 such that the firing bar 6255 slides relative to the staples 6230. In such instances, as a result, the staples 6230 index into the next distal set of recesses 6252 defined in the firing bar 6255, thereby presenting a new set of staples 6230 to be ejected from the staple cavity 6221. FIGS. 130 and 130A depict the surgical instrument 6200 as it is being re-opened to release the patient tissue so that the distal head 6220 can be repositioned relative to the patient tissue. Once the distal head 6220 has been suitably re-positioned, referring to FIG. 137, the firing bar 6255 can be advanced distally to perform a second staple firing stroke. This process can be repeated to deploy all of the staples 6230 stored in the firing bar 6255.

**[0313]** The stapling instruments disclosed herein can be configured to deploy staples in a suitable staple pattern. FIG. 138 depicts one exemplary staple pattern comprising staples 6330 and staples 6330' positioned on both sides of a tissue cut line 6340. Each side of the tissue cut line 6340 comprises an inner row of staples 6330 facing away from the cut line 6340 and an outer row of staples 6340 facing toward the cut line 6340. FIG. 139 depicts another exemplary staple pattern comprising staples 6330, staples 6330', and staples 6430". The staples 6430" are arranged in rows on both sides of the tissue cut line 6340. More specifically, the staples 6430" are arranged in staple rows positioned intermediate both sets of inner row of staples 6330 and outer row of staples 6330'.

**[0314]** Referring to FIGS. 140 and 141, a stapling instrument 6500 comprises a shaft 6510, a distal head 6520, and an articulation joint 6270 rotatably connecting the distal head 6520 to the shaft 6510. The stapling instrument 6500 further comprises a staple feeding system 6590 configured to manufacture and supply a continuous feed of staples 6530 to the distal head 6520. The staple feeding system 6590 comprises a spool 6592 operably coupled to an electric motor. The spool 6592 comprises metal wire 6594 wrapped around a central core. The wire 6594 is comprised of stainless steel and/or titanium, for example. The wire 6594 is fed through a passage 6514 defined in the shaft 6510 and the articulation joint 6570. In use, the motorized spool 6594 pushes the wire 6594 into the distal head 6520. As described in greater detail below, the distal head 6520 further comprises a forming mandrel configured to deform the wire 6594 into a staple 6530. The mandrel is driven by an electric motor and/or actuator, but could be actuated in any suitable manner. As also described in greater detail below, the distal head 6520 comprises a knife, or shearing member, configured to cut the wire 6594. The shearing member is driven by an electric motor and/or actuator, but could be actuated in any suitable manner. Once the staple 6530 has been formed and separated from the wire 6594, the staple 6530 can be deployed and deformed against an anvil 6560 of the stapling instrument 6500.

**[0315]** Referring to FIG. 141, the surgical instrument 6500 further comprises a staple forming system 6580 configured to create staples 6530 from the wire 6594. The staple forming system 6580 comprises a forming mandrel 6582 positioned in a forming cavity 6522 defined in the distal head 6520. The staple forming system 6580 further comprises a forming actuator 6584 configured to engage the wire 6594 and deform the wire 6594 within the forming cavity 6522. At such point, the forming mandrel 6582 is actuated to sever the staple 6530 from the wire 6594. After the staple 6530 has been deployed and/or moved out of the forming cavity 6522, another staple 6530 can be formed within the cavity 6522. In certain alternative embodiments, a wire segment is cut from the metal wire 6594 before the wire segment is formed into a staple 6530. In either event, the staple 6530 can comprise a substantially U-shaped configuration, for example. Alternatively, the wire segment can be formed into a substantially V-shaped configuration. Moreover, the stapling instrument 6500 can be configured to

manufacture and deploy any suitable fastener, such as tacks and/or clamps, for example.

**[0316]** Referring to FIGS. 158 and 159, a stapling instrument 7300 comprises a shaft 7310, a distal head 7320, and an articulation joint 7370 rotatably connecting the distal head 7320 to the shaft 7310. In use, the stapling instrument 7300 is inserted into a patient P through a trocar TC. The trocar TC comprises a passage extending there through which permits the distal head 7320, and a portion of the shaft 7310, to be inserted into the patient. In other instances, the distal head 7320 can be inserted into the patient through an open incision without a trocar. In either event, the stapling instrument 7300 is configured to deploy staples from a staple cartridge inserted therein. The shaft 7310 comprises a loading port 7312 which is in communication with a cartridge passage, or channel, extending through the shaft 7310, the articulation joint 7370, and the distal head 7320. In use, a staple cartridge, such as staple cartridge 7330', for example, is inserted into the shaft 7310 through the loading port 7312 and then pushed into the distal head 7320. The stapling instrument 7300 further comprises a cartridge pusher system configured to push the staple cartridge 7330' into the end effector 7300.

**[0317]** In various instances, further to the above, staple cartridges 7330' can be fed into the stapling instrument 7300 such that the stapling instrument 7300 can be continuously operated without having to be removed from the patient to be reloaded. Each staple cartridge 7330' has staples stored therein which have a first size, such as a first unfired height. In certain instances, it is desirable to create a staple line with staples all having the same size, or unfired height. Such instances can arise when the tissue being stapled has a substantially uniform thickness. In other instances, it is desirable to create a staple line with staples having different sizes, or unfired heights. Such instances can arise when the tissue being stapled does not have a uniform thickness. For instance, stomach tissue transected during a stomach reduction procedure usually does not have a consistent thickness. In such instances, a first staple cartridge 7330' can be loaded into the stapling instrument 7300 that has staples having a first unfired height and a second staple cartridge 7330'' can be loaded into the stapling instrument 7300 having a second unfired height. The first unfired height is

taller than the second unfired height, but the first unfired height could be shorter than the second unfired height. Similarly, a third staple cartridge 7330''' can be loaded into the stapling instrument 7300 that has staples having a third unfired height which is different than the first unfired height and the second unfired height.

**[0318]** Further to the above, more than one staple cartridge can be loaded into the stapling instrument 7300. The staple cartridges can be inserted into the stapling instrument 7300 such that they are used in a specific order. For instance, staple cartridges having shorter unfired heights can be fired before staple cartridges having taller unfired heights. Alternatively, staple cartridges having taller unfired heights can be fired before staple cartridges having shorter unfired heights. In any event, the distal-most staple cartridge is used first and the proximal-most staple cartridge is used last. Such an arrangement allows the surgical procedure to be pre-planned with little, if any, lost time in loading the stapling instrument 7300 during the surgical procedure. Alternatively, the staple cartridges can be fed into the stapling instrument 7300 one at a time. Such an arrangement provides a clinician with an opportunity to change the order in which the staple cartridges are ultimately used.

**[0319]** The loading port 7312 comprises an opening accessible from the exterior of the shaft 7310, although the loading port 7312 could be defined in the handle of the stapling instrument 7300 or in any other suitable location. In various instances, the stapling instrument 7300 can further comprise a door configured to cover the loading port 7312. In at least one instance, the door can be sealed, when closed, to prevent or inhibit the ingress of fluids and/or contaminants into the stapling instrument 7300. In such instances, the door and/or the housing of the shaft 7310 can comprise one or more seals.

**[0320]** Referring primarily to FIG. 159, the stapling instrument 7300 comprises a system for stripping off a cluster of staples, such as staples 7330, for example, from the distal-most staple cartridge. The stapling instrument 7300 further comprises a staple firing system 7350 configured to deploy the staples 7330 and deform the staples 7330 against an anvil 7360 during a staple firing stroke. The stapling instrument 7300 further comprises a tissue drive system 7380 configured to move the distal head 7320 relative to the patient tissue after the staple firing stroke.

**[0321]** Referring to FIGS 168 and 169, a stapling instrument 7900 comprises a shaft 7910, a distal head 7920, and an articulation joint 7970 rotatably connecting the distal head 7920 to the shaft 7910. As described in greater detail below, the distal head 7920 is pivotable in any suitable direction. Similar to the above, the stapling instrument 7900 comprises a cartridge feeding system configured to feed staple cartridges 7930' into the distal head 7920 through a cartridge passage 7914 that extends through the shaft 7910, the articulation joint 7970, and the distal head 7920. Also similar to the above, staples 7930 are stripped from the distal-most staple cartridge 7930' and then fired against an anvil 7960. As described in greater detail below, the stapling instrument 7900 further comprises an articulation drive system 7980 configured to articulate the distal head 7920.

**[0322]** Further to the above, referring again to FIGS. 168 and 169, the distal head 7920 is articulatable in several directions relative to the shaft 7910. The shaft 7910 extends along a longitudinal shaft axis LA and the distal head 7920 extends along a longitudinal head axis HA. The head axis HA is aligned, or at least substantially aligned, with the shaft axis LA when the distal head 7920 is not articulated. When the distal head 7920 is articulated, the head axis HA is transverse to the shaft axis LA. Referring to FIG. 168, the distal head 7920 is articulatable laterally, or in a side-to-side direction. In at least one such instance, the distal head 7920 is articulatable within a range comprising about 15 degrees to a first side of the shaft axis LA and about 15 degrees to a second side of the shaft axis LA, for example. The articulation drive system 7980 is configured to drive, or actively articulate, the distal head 7920 through this range of motion. The articulation drive system 7980 comprises a first lateral driver 7982 mounted to the distal head 7920 and a second lateral driver 7984 mounted to the distal head 7920 on the opposite side of the distal head 7920. In use, the first lateral driver 7982 is pushed and/or the second lateral driver 7984 is pulled to articulate the distal head 7920 in a first direction. Correspondingly, the first lateral driver 7982 is pulled and/or the second lateral driver 7984 is pushed to articulate the distal head 7920 in a second direction. In at least one instance, the first lateral driver 7982 comprises a first guide wire and the second lateral driver 7984 comprises a second guide wire. Such guide wires are suitable for pulling the distal head 7920.

**[0323]** Referring to FIG. 169, the distal head 7920 is also articulatable in a forward and/or backward direction. In at least one such instance, the distal head 7920 is articulatable within a range comprising about 25 degrees in a backward direction and about 25 degrees in a forward direction, for example. In certain embodiments, although not illustrated, the articulation drive system 7980 is configured to actively articulate the distal head 7920 in the forward and backward (FIG. 169) directions. In alternative embodiments, the distal head 7920 can be passively articulated in the forward and backward directions. In such embodiments, the stapling instrument 7900 does not actively drive the distal head 7920 relative to the shaft 7910. Instead, the distal head 7920 can float in the forward-to-backward direction. Similarly, the distal head 7920 can be passively articulated in the side-to-side direction with or without the articulation drive system 7980. In any event, the distal head 7920 is articulatable in both the forward-to-back and side-to-side planes and can take a compound angle with respect to the longitudinal axis LA of the shaft 7910.

**[0324]** In various embodiments, the surgical instrument 7900 can comprise a lock configured to hold the distal head 7920 in position which can be released to allow the distal head 7920 to move relative to the shaft 7910. In various instances, the distal head 7920 can be passively articulated by pushing the distal head 7920 against the patient tissue within the surgical site when the distal head 7920 is unlocked. The distal head 7920 could also be actively articulated when the distal head 7920 is unlocked. In either event, the distal head 7920 can then be locked in its articulated position once the distal head 7920 has been suitably positioned. In order to return the distal head 7920 to its unarticulated position, the distal head 7920 can be unlocked and then re-aligned with the shaft axis LA. In at least one instance, the stapling instrument 7900 comprises one or more springs configured to bias the distal head 7920 into its unarticulated position. In any event, the articulation lock can prevent, or at least inhibit, the back-driving of the distal head 7920 in response to external and/or internal forces and torques.

**[0325]** Further to the above, the articulation joint 7970 of the stapling instrument 7000 permits the distal head 7920 to be articulated about one or more axes. In various alternative embodiments, the shaft of a stapling instrument comprises a first articulation joint which permits a distal head to articulate about a first articulation axis and a second

articulation joint which permits the distal head to articulate about a second articulation axis. The first articulation axis and the second articulation axis extend in planes which are orthogonal, but can extend in any suitable transverse planes. In various instances, the first and second articulation joints are passively articulated. In some instances, the first and second articulation joints are actively articulated. In at least one instance, the first articulation joint is actively articulated and the second articulation joint is passively articulated.

**[0326]** Referring to FIG. 170, a stapling instrument 8000 comprises a dampening system 8080 configured to control, or slow, the articulation of the distal head 7920. The dampening system 8080 comprises a first link 8082, a second link 8084, and a dashpot 8085. The first link 8082 is pinned to the distal head 7920 at a pivot 8081. The first link 8082 is also pinned to the second link 8084 at a pivot 8083. The pivots 8081 and 8083 allow the dampening system 8080 to accommodate the various articulation motions of the distal head 7920. The dashpot 8085 comprises a housing 8087 mounted to the shaft 7910 and a dampening medium 8088 contained in a chamber defined in the housing 8087. The second link 8084 comprises a piston 8086 defined on its proximal end which is positioned in the housing aperture and is configured to move through the dampening medium 8088 when the distal head 7920 is articulated. The dampening medium 8088 flows through and/or around the piston 8086, thereby permitting, but slowing, relative movement between the piston 8086 and the housing 8097. Correspondingly, the dampening medium 8088 permits, but slows, the movement of the distal head 7920 relative to the shaft 7910. Sudden movements of the distal head 7920 may be hard for the clinician to control and/or anticipate and may cause the distal head 7920 to strike the patient tissue. The dampening medium 8088 can comprise any suitable medium, such as dampening grease, for example.

**[0327]** Referring to FIG. 171, a stapling instrument 8100 comprises a dampening system 8180 configured to control, or slow, the articulation of the distal head 7920. The dampening system 8180 comprises a link 8182 and a dashpot 8185. The link 8182 is pinned to the distal head 7920 at a pivot 8181. The first link 8082 is flexible, thereby allowing the dampening system 8180 to accommodate the various articulation motions of the distal head 7920. The dashpot 8185 comprises a housing 8187 rotatably

mounted to the shaft 7910 and a dampening medium 8188 contained in a chamber defined in the housing 8187. The link 8182 comprises a piston 8186 defined on its proximal end which is positioned in the housing aperture and is configured to move through the dampening medium 8188 when the distal head 7920 is articulated. The dampening medium 8188 flows through and/or around the piston 8186, thereby permitting, but slowing, relative movement between the 8186 and the housing 8197. Correspondingly, the dampening medium 8188 permits, but slows, the movement of the distal head 7920 relative to the shaft 7910. Sudden movements of the distal head 7920 may be hard for the clinician to control and/or anticipate and may cause the distal head 7920 to strike the patient tissue. The dampening medium 8188 can comprise any suitable medium, such as dampening grease, for example.

**[0328]** Referring to FIG. 172, the stapling instrument 8100 is insertable into a patient P through a trocar TC and is movable relative to the target tissue T. To a certain extent, the trocar TC can be moved relative to the patient P and, also to a certain extent, the stapling instrument 8100 can be moved relative to the trocar TC. Such movement, however, may cause the shaft 7910 to move through a wide range of angles. In order to keep the distal head 7920 aligned with the tissue as the distal head 7920 is progressed along the staple line, the distal head 7920 can be progressively articulated backwards, for example. Referring to FIG. 173, the distal head 7920 can be progressively articulated forward and/or backward to keep the axis of the distal head 7920 orthogonal, or at least substantially orthogonal, to the target tissue T. In various instances, the distal head 7920 is actively articulated by an articulation drive system to adjust the angle between the distal head 7920 and the shaft 7910. In certain instances, the distal head 7920 is passively articulated by an articulation drive system to adjust the angle between the distal head 7920 and the shaft 7910. In such instances, the distal head 7920 can adaptively float to follow the staple firing path.

**[0329]** Referring to FIGS. 34 and 35, a stapling instrument 2500 comprises a shaft 2510, a distal head 2520, and an articulation joint 2570 rotatably connecting the distal head 2520 to the shaft 2510. The shaft 2510 extends along a longitudinal shaft axis LA and the distal head 2520 extends along a longitudinal head axis HA. The shaft axis LA and the head axis HA are aligned when the distal head 2520 is not articulated, as

illustrated in FIG. 34. Referring to FIG. 35, the head axis HA is transverse to the shaft axis LA when the distal head 2520 is articulated. The stapling instrument 2500 further comprises a dampening system 2580 configured to control, or slow, the articulation of the distal head 2520. The dampening system 2580 comprises a first link 2581, a second link 2582, and a dashpot 2585. The first link 2581 is pinned to the distal head 2520 at a pivot 2584. The first link 2581 is also pinned to the second link 2582 at a pivot 2583. The pivots 2583 and 2584 allow the dampening system 2580 to accommodate the various articulation motions of the distal head 2520. When the distal head 2520 is not articulated, referring to FIG. 34, the first link 2581 is aligned with the second link 2582 along a longitudinal axis. When the distal head 2520 is articulated, referring to FIG. 35, the first link 2581 is transverse to the second link 2582.

**[0330]** The dashpot 2585 comprises a housing mounted to the shaft 2510 and a dampening medium 2586 contained in a chamber defined in the housing. The second link 2582 comprises a piston defined on its proximal end which is positioned in the housing aperture and is configured to move through the dampening medium 2586 when the distal head 2520 is articulated. The dampening medium 2586 flows through and/or around the piston, thereby permitting, but slowing, relative movement between the piston and the housing. Correspondingly, the dampening medium 2586 permits, but slows, the movement of the distal head 2520 relative to the shaft 2510. The dampening medium 2586 can comprise any suitable medium, such as dampening foam, for example.

**[0331]** A stapling instrument 2000 is illustrated in FIG. 13 and is similar to the stapling instrument 1000 and/or the other stapling instruments disclosed herein in many respects, most of which will not be discussed herein for the sake of brevity. The stapling instrument 2000 comprises a handle 2100 including a housing 2110, a grip 2120, and a display 2130. The housing 2110 comprises a connector 2170 which is configured to connect a shaft assembly, such as shaft assembly 1200, for example, to the handle 2100. The handle 2100 further comprises a replaceable battery pack 2160 which is releasably attached to the housing 2110 and removably positioned within a cavity 2115 defined in the housing 2110. The battery pack 2160 supplies power to the display 2130 and/or the motor-driven systems contained within the handle 2100. As

discussed in greater detail below, the display 2130 is configured to permit the user to control the operation of the surgical instrument 2000.

**[0332]** Further to the above, the stapling instrument 2000 comprises a staple firing system configured to apply a staple line in the tissue of a patient and the display 2130 comprises controls for evaluating the status of the staple firing system. The display 2130 also comprises controls for evaluating and/or altering the speed in which the stapling instrument 2000 is applying the staple line, the direction in which the staple line is being applied, and/or any performance thresholds that have been met, exceeded, or are about to be exceeded, for example. The display 2130 comprises a capacitive touchscreen; however, any suitable screen could be used.

**[0333]** Referring to FIG. 14, the display 2130 comprises a status control 2140. The status control 2140 comprises a window 2141 including a window header 2142. The status control 2140 further comprises an image window 2145 configured to display information regarding the tissue being stapled, the staple firing path, and/or any other information that the clinician may use to operate the stapling instrument 2000. For instance, the image window 2145 is configured to display the staple firing path 2143 that the stapling instrument 2100 is currently moving along and/or an alternate staple firing path 2143' which would guide the staple path around certain anatomical features in the patient tissue T, such as a blood vessel V, for example. The status control 2140 is a digital control and/or display and is signal communication with a controller of the stapling instrument 2000.

**[0334]** Referring to FIG. 17, the display 2130 further comprises a direction control 2190 which is configured to control the direction of the staple firing path. The direction control 2190 comprises a window 2191 including a window header 2192 and an image window 2195. The image window 2195 is configured to display the orientation of the distal head of the stapling instrument relative to an original starting orientation. The image window 2195 comprises a plurality of orientation lines 2194 indicating certain direction angles, such as 15 degrees, 30 degrees, and 45 degrees, for example, relative to the starting orientation line 2194 demarcated as 0 degrees. The image window 2195 further comprises a needle 2193 which represents the orientation of the distal head of the stapling instrument relative to the starting orientation of the stapling instrument. The

direction control 2190 further comprises an edit window 2198 which, once activated, allows the user to alter the direction of the staple path by manipulating the needle 2193. The direction control 2190 further comprises a save window 2199 which, once activated, allows the user to save the input provided to the controller through the direction control 2190. At such point, the stapling instrument 2000 can move along its new orientation. The status control 2190 is a digital control and/or display and is signal communication with the controller of the stapling instrument 2000.

**[0335]** Referring to FIG. 15, the display 2130 further comprises a speed control 2150 configured to control speed in which the stapling instrument 2000 creates the staple path. The speed control 2150 comprises a window 2151 including a window header 2152 and an image window 2155. The image window 2155 comprises an indicator 2153 configured to display the speed of the stapling instrument. For instance, the indicator 2153 can display that number of staple firing strokes that the stapling instrument 2000 is performing per minute. The image window 2155 further comprises an up-arrow control 2156 which is actuatable to increase the rate of the staple firing strokes and a down-arrow control 2157 which is actuatable to decrease the rate of the staple firing strokes. The indicator 2153 can be configured to display the speed in which the stapling instrument 2000 is being propelled across the patient tissue by the tissue drive system. Other metrics for the speed of the stapling instrument 2000 can be used and displayed. The status control 2150 is a digital control and/or display and is signal communication with the controller of the stapling instrument 2000.

**[0336]** Referring to FIG. 16, the display 2130 further comprises a fault threshold control 2180 which is configured to manage fault thresholds of the stapling instrument 2000 as they arise. For instance, a threshold for the force needed to perform a staple firing stroke can be used to establish a fault condition which requires input from the user. If the force needed to perform a staple firing stroke exceeds the threshold, the controller of the stapling instrument 2000 can warn the user via the fault threshold control 2180 and/or stop the stapling instrument 2000. Certain faults can be over-ridden, or otherwise managed, by the user which can allow the stapling instrument 2000 to continue applying the staple line. The fault threshold control 2180 permits the user to manage these faults. Other faults may not be over-ridden. In such instances, the fault

threshold control 2180 is configured to display to the user that the fault cannot be overridden and/or how to resolve the fault such that the operation of the stapling instrument 2000 can be continued. The fault threshold control 2180 comprises a window 2181 including a window header 2182 and an image window 2185. The fault threshold control 2180 is a digital control and/or display and is signal communication with the controller of the stapling instrument 2000.

**[0337]** Turning now to FIG. 18, the stapling instrument 2000 further comprises a vision acquisition system, discussed in greater detail below, and the display 2130 further comprises an image window 2135 configured to display, among other things, a real-time video image from the vision acquisition system. The display 2130 further comprises a menu 2131 extending along the left side of the image window 2135; however, the menu 2131 could be placed in any suitable location on the display 2130. The menu 2131 includes the status control 2140, the speed control 2150, the fault threshold control 2180, and the direction control 2190 discussed above. The menu 2131 also includes a settings control 2132 which can be used to select and/or rearrange the windows and/or controls on the display 2130. The menu 2131 further includes a stop control 2136 which can immediately stop the progression of the stapling instrument 2100 along the staple firing path. The menu 2131 is a digital control and/or display and is signal communication with the controller of the stapling instrument 2100.

**[0338]** Further to the above, referring again to FIG. 18, the display 2130 further comprises a first view window 2133 and a second view window 2134. The view windows 2133 and 2134 are positioned along the right side of the image window 2135, but could be placed in any suitable location on the display 2130. The view windows 2133 and 2134 provide the user with alternate views of the stapling instrument 2000. For instance, the first view window 2133 provides the user with a side view of the stapling instrument 2000 in the surgical site and the second view window 2134 provides the user with a top view of the stapling instrument 2000 in the surgical site. These additional views can be supplied by one or more digital cameras on the stapling instrument 2000 and/or from other surgical instruments, such as an endoscope, for example, in the surgical site. In such instances, the other surgical instruments are in signal communication with the controller of the stapling instrument 2000 to provide

these additional images. In certain instances, the controller of the stapling instrument 2000 can interpret data provided to the controller and generate the additional images for the windows 2133 and 2134 based on the provided data.

**[0339]** As discussed above, the speed in which the staple firing system and/or the tissue drive system of the stapling instrument 2000 is operated can be controlled by the speed control 2150 on the display 2130. In various instances, as discussed above, the speed can be controlled manually, or by an input from the user. In other instances, the controller of the stapling instrument 2000 can control the speed automatically. In such instances, the controller is configured to evaluate the properties of the tissue being stapled, such as its thickness and/or density, for example, and adjust the speed of the staple firing system and/or the tissue drive system accordingly. For instance, if the controller determines that the tissue being stapled is thick, or is near, at, or over a tissue thickness threshold, the controller can slow down the speed of the stapling instrument 2000. Similarly, the controller can slow down the speed of the stapling instrument 2000 if the controller determines that the tissue being stapled is dense, or is near, at, or over a tissue density threshold, for example. Correspondingly, the controller can speed up the speed of the stapling instrument 2000 if the controller determines that the tissue being stapled is thin or less dense than usual, for example. Further to the above, referring to FIG. 19, the speed control 2150 of the stapling instrument 2000 comprises an option for the user to select between an automatic speed control 2158 in which the stapling instrument 2000 controls the speed of the stapling instrument 2000 and a manual speed control 2159 in which the user controls the speed of the stapling instrument 2000.

**[0340]** Referring to FIG. 20, a stapling instrument 2200 comprises a display 2230. The stapling instrument 2200 is similar to the stapling instrument 2000 in many respects and the display 2230 is similar to the display 2130 in many respects, most of which will not be discussed herein for the sake of brevity. The display 2230 comprises a menu 2231 and a center image window 2235. The center image window 2235 displays an image of the patient tissue T being stapled and a staple firing path 2243 along which the stapling instrument 2200 is moving. The staple firing path 2243 is displayed as a series of actuations, or staple firings, 2244. Each projected actuation 2244 shows the path in

which the tissue T will be incised and the positions in which staple clusters 2245 will be deployed into the tissue T relative to the tissue incision. The projected actuation 2244 nearest to the distal head of the stapling instrument 2200 is highlighted relative to the other projected actuators 2244 so that the user can differentiate between the upcoming staple firing and subsequent projected staple firings. Such highlighting can include a different color and/or brightness of color, for example, of the projected actuation 2244. In at least one instance, the displayed actuators 2244 of the staple firing path 2243 can be progressively less intense as they move away from the distal head of the stapling instrument 2200.

**[0341]** Further to the above, the display 2230 is further configured to display one or more alternative staple firing paths. For instance, the display 2230 is configured to display an alternative staple firing path 2243' in the center image window 2235. Similar to the staple firing path 2243, the staple firing path 2243' is displayed as a series of actuators, or staple firings, 2244'. Each projected actuation 2244' shows the path in which the tissue T will be cut and the positions in which the staple clusters 2245 will be deployed in the tissue T. The menu 2231 comprises a staple line control 2240 which can be actuated by the user of the stapling instrument 2200 to edit the staple firing path 2243 to create the alternate staple firing path 2243'. Once the alternate staple firing path 2243' has been established, it can be saved and the stapling instrument 2200 can be operated to follow the alternate staple firing path 2243'. As illustrated in FIG. 20, the staple line control 2240 comprises an actuatable edit sub-control 2241 and an actuatable save sub-control 2242 to modify and save the staple firing path as described above.

**[0342]** As described above, the staple firing path 2243 is modifiable into an alternate staple firing path 2243'. The staple firing path 2243 and the alternate staple firing path 2243' are displayed in an image which overlays the video image from the camera. The staple firing path 2243 and the alternate staple firing path 2243' are displayed in the same image overlay, or layer, but could be displayed in different image overlays, or layers. In at least one such instance, the staple firing path 2243 is displayed in a first image overlay, or layer, and the alternate staple firing path 2243' is displayed in a second image overlay, or layer, which is different than the first image overlay. The

screen of the display 2230 is configured to receive an input command from the center image window 2235 which can drag the staple firing path 2243 and/or the alternate staple firing path 2243' within the image overlay, or overlays. The screen of the display 2230 is configured to be responsive to the finger of the user such that the staple firing path can be modified by the user dragging their finger. Referring to FIG. 21, the screen of the display 2230 is further configured to be responsive to a stylus 2220, for example.

**[0343]** As discussed above, the display 2230 can be configured to display the current, or intended, staple firing path and one or more alternate staple firing paths. The controller of the stapling instrument 2200 is configured to generate one or more alternate staple firing paths and display these alternate staple firing paths on the display 2230. In various instances, the controller can determine the alternate staple firing paths based on one or more attributes of the tissue T being stapled. For instance, the controller can identify blood vessels within the tissue T and provide, or offer, an alternate staple firing path which steers the stapling instrument 2200 around the blood vessels.

**[0344]** Referring to FIG. 22, the display 2230 comprises a menu including a plurality of controls which are configured to modify the staple firing path while the stapling instrument 2200 is deploying the staple path and/or after the stapling instrument 2200 has been stopped. The display 2230 comprises a menu 2231 including a plurality of actuable controls which are configured to be used while the stapling instrument 2200 is performing its series of staple firing strokes to create the staple path. The menu 2231 comprises a view control 2232 to change the video image displayed in the center image window 2235, for example. In at least one such instance, the video control can be used to toggle between different video feeds. The menu 2231 further comprises the staple line 2240 control, discussed above, which is configured to modify the staple firing path. The staple firing system of the stapling instrument 2200 can be started by the user actuating a stapling control 2234 in the menu 2231 and stopped by the user actuating a stop control 2236 in the menu 2231.

**[0345]** Further to the above, the shaft assembly attached to the handle of the stapling instrument 2200 can be rotated relative to the handle. The shaft assembly includes a rotatable slip joint configured to permit the distal head of the shaft assembly to rotate

relative to the handle, although any suitable arrangement can be used. As a result of this slip joint, the user of the stapling instrument 2200 can selectively orient the display 2230 relative to the distal head of the stapling instrument 2200. In such instances, the user can maintain the orientation of the display 2230 with respect to the patient, for example, even though the distal head is turning to follow the staple firing path.

Similarly, FIGS. 144-146 depict the stapling instrument 1000 inserted into a patient P through a trocar TC and, owing to a rotatable interface between the handle display and shaft assembly of the stapling instrument 1000, the handle display can be maintained by the clinician C in a constant orientation relative to themselves even though the shaft assembly is rotating to follow the staple firing path FP.

**[0346]** Referring to FIGS. 147-150, a stapling instrument 7000 comprises a handle 7010 including a grip 7020 and a shaft assembly 1200 assembled to the handle 7010. The handle 7010 further comprises a display 7030 rotatably attached to the handle 7010 about a rotation joint 7035. The display 7030 is similar to the display 2230 in many respects, most of which will not be discussed herein for the sake of brevity. In use, the display 7030 can be rotated relative to the handle 7010 to maintain a suitable orientation of the display 7030 relative to the clinician C and/or any other frame of reference.

**[0347]** FIG. 180 depicts a handle 1500 of a surgical instrument 100 for use by a clinician during a surgical procedure. The handle 1500 comprises a central portion 110 bordered by one or more ergonomic grips 120 to facilitate handling of the surgical instrument 100 by the clinician. Each ergonomic grip 120 is configured to fit within a hand of the clinician for enhanced control and comfort. The handle 1500 comprises one or more interactive controls 180 configured to provide navigation commands to an end effector of the surgical instrument 100. In various instances, one or more interactive controls 180 are configured to provide a user command corresponding to a selection of one or more items. The interactive controls 180 are positioned on the handle 1500 in a location that allows for easy operation by the clinician, such as in a location within reaching distance of a clinician's thumb. In various instances, the controls 180 are comprised of various types of switches and/or buttons, for example. In various instances, the interactive controls 180 comprise a toggle switch, an analog stick, a

rocker, a D-pad, and/or any other suitable interactive control capable of facilitating the communication of a user command to the controller of the surgical instrument 100, for example.

**[0348]** The handle 1500 further comprises a touch-sensitive display 1510. A portion of the touch-sensitive display 1510 displays a menu bar 1512 to the clinician. The options of the menu bar 1512 represent various display modes of the surgical instrument 100 including, but not limited to, a view mode, a position mode, and/or a staple mode. In the various display modes, data and/or images relevant to the surgical procedure and/or the status of surgical instrument 100 are displayed. In the view mode, the touch-sensitive display 1510 displays a plurality of views of the surgical site, including, for example, a side view and a top view. The side view and the top view are displayed in separate frames 1514, 1516 of the touch-sensitive display 1510, although they could be displayed in any suitable manner. The clinician is able to focus on a particular view by switching the desired view into an enlarged, centralized frame 1518 using the interactive controls 180, as described above. In various embodiments, the clinician can switch between views by dragging the desired view toward the central frame 1518 with an input device 1530, such as a stylus or a finger of the clinician, for example. The input device 1530 is described in greater detail below.

**[0349]** In order to create a sterile environment for the surgical instrument 100, a sterile barrier 190 is draped over the handle 1500, as seen in FIG. 181. As will be discussed in greater detail below, the sterile barrier 190 is comprised of a clear, elastic material, such as plastic, for example. The sterile barrier 190 extends around the handle 1500 and onto a proximal portion of the shaft 200. The sterile barrier 190 comprises one or more pre-molded areas 192 configured to fit over the interactive controls 180. The pre-molded areas 192 assist in aligning the sterile barrier 190 over the handle 1500 of the surgical instrument 100. The sterile barrier 190 is stretched over the touch-sensitive display 1510 to create a smooth, uniform barrier, or an at least substantially smooth, uniform barrier. Attachment members 194, such as clips, for example, secure the sterile barrier 190 in position around a perimeter 193 of the touch-sensitive display 1510. The sterile barrier 190 fits loosely around the remaining components of the handle 1500, and the sterile barrier 190 is cinched around the shaft 200 of the surgical

instrument 100, although any suitable arrangement can be used. Covering the handle 1500 with the sterile barrier 190 protects various components of the handle 1500 from exposure to bodily fluids and/or contaminants, for example. Draping the sterile barrier 190 over the handle 1500 and the proximal portion of the shaft 200 also provides a cost-effective and rapid means for the handle 1500 of the surgical instrument 100 to be sterilized and reused.

**[0350]** FIG. 182 depicts a touch-sensitive display assembly 500. The touch-sensitive display assembly 500 comprises a sterile barrier 190 and a touch-sensitive display 1510. In certain instances, the touch-sensitive display 1510 acts as a projected capacitive sensor. The touch-sensitive display 1510 comprises an insulative layer 1511 comprised of an insulative material mounted on top of a sensing mechanism 1513. In certain instances, the insulative layer 1511 is mounted to the sensing mechanism 1513 by a bonding adhesive, such as an optical bonding adhesive, for example. As discussed above, the sterile barrier 190 is stretched over the touch-sensitive display 1510 in a uniform, or nearly uniform, fashion. Attachment members 194 (FIG. 181) retain the sterile barrier 190 in its stretched position in a manner that creates a gap 1520 in between the sterile barrier 190 and the insulative layer 1511. The gap 1520 spans a distance of a few millimeters between the insulative layer 1511 and the sterile barrier 190, and the gap 1520 is configured to prevent the formation of contact bubbles should the sterile barrier 190 come into contact with the insulative layer 1511.

**[0351]** Conductive particles 191 are dispersed throughout the sterile barrier 190, giving the sterile barrier 190 a particular capacitance. The sensing mechanism 1513 of the touch-sensitive display assembly 500 comprises a plurality of pixels 1515 and a material, such as indium tin oxide, for example, configured to create electrodes. In various instances, as discussed in more detail with respect to FIG. 183, the electrodes are arranged in an orthogonal grid, although any suitable arrangement can be used. Among other things, the sensing mechanism 1513 is configured to detect when the sterile barrier 190 is attached. More specifically, the sensing mechanism 1513 detects attachment of the sterile barrier 190 by the particular capacitance of the sterile barrier 190. When a clinician wants to utilize the functionality of the touch-sensitive display 1510, the input device 1530, as mentioned above, is brought into contact with the sterile

barrier 190 at a desired contact point. The sensing mechanism 1513 is configured to detect the additional capacitance of the input device 1530 and differentiate the capacitance of the input device 1530 from the capacitance of the sterile barrier 190. Moreover, as the input device 1530 is brought into contact with the sterile barrier 190, the conductive particles 191 of the sterile barrier 190 are compressed, or brought closer together. Such compression creates a higher density of conductive particles 191 in the area surrounding the contact point of the input device 1530, and thus, a higher capacitance. Pixels 1515 of the sensing mechanism 1513 become activated or energized in the vicinity of the contact point due to the change in electrical charge at the contact point in the sensing mechanism 1513.

**[0352]** The touch-sensitive display 1510 is configured to function in the same and/or similar manner without the sterile barrier 190. In certain instances, the input device 1530 is comprised of a finger of the clinician enclosed by a latex glove, for example. Medical latex gloves are typically thin enough so as not to impede the conductive qualities of a clinician's finger. In instances where a glove worn by the clinician is expected to dampen the conductive qualities of the clinician's finger, settings of the touch-sensitive display 1510 can be altered to increase sensitivity of the sensing mechanism 1513.

**[0353]** FIG. 183 depicts the touch-sensitive display 1510 of FIG. 182 when an input device 1530 contacts the sterile barrier 190 of the touch-sensitive display assembly 500. As mentioned above, in various instances, the electrodes are arranged in an orthogonal grid, although any suitable arrangement can be used. In such instances, the electrodes comprise x-electrodes 1542 and y-electrodes 1544. The touch-sensitive display 1510 comprises a plurality of pixels 1515 arranged in a uniform, or nearly uniform, fashion throughout the sensing mechanism 1513, although any suitable arrangement can be used. FIG. 183 further depicts various groupings of activated pixel clusters 1517 and 1519. During its unactivated state, a low-level capacitance is present across all of the pixels 1515 (FIG. 182) in the touch-sensitive display 1510. When the input member 1530 (FIG. 182) contacts the sterile barrier 190 and activates the touch-sensitive display 1510, the pixels 1515 associated with pixel clusters 1517 and 1519 are activated with a new, higher capacitance. The pixels 1515 in the pixel clusters 1517 and 1519 become

activated as the input device 1530 continues to make contact with the sterile barrier 190. The sensing mechanism 1513 detects the location of the active pixel clusters 1517, 1519 by scanning the matrix of x-electrodes 1542 and y-electrodes 1544.

**[0354]** FIG. 184 depicts a graphical representation 1550 of the relationship between the location of active pixel clusters within the x-electrodes 1542 of the touch-sensitive display 1510 and the detected capacitance by the sensing mechanism 1513. A first capacitance  $C_1$  is indicative of the low-level, or unactivated, capacitance present across the pixels 1515 of the touch-sensitive display 1510 prior to application of the sterile barrier 190. By way of reference, capacitance  $C_0$  represents a detected capacitance of zero, and capacitance  $C_1$  represents a capacitance of more than zero. A second capacitance  $C_2$  is indicative of a threshold capacitance. When the threshold capacitance  $C_2$  is exceeded, the surgical instrument 100 recognizes that the sterile barrier 190 is attached to the touch-sensitive display 1510. In the graphical representation 1550, the sterile barrier 190 is attached to the touch-sensitive display 1510, as the detected capacitance is above the threshold capacitance  $C_2$ . A third capacitance  $C_3$  represents another threshold capacitance. When the sensing mechanism 1513 detects a capacitance that is greater than the threshold capacitance  $C_3$ , the surgical instrument 100 recognizes that the input device 1530 is in contact with the sterile barrier 190. In the graphical representation 1550, the input device 1530 is in contact with the sterile barrier 190 in two locations, as the detected capacitance exceeds the threshold capacitance  $C_3$  twice. When the input device 1530 is removed from the sterile barrier 190, the capacitance detected by the pixels 1515 in clusters 1517 and 1519 returns to the capacitance to below  $C_3$ , but above or equal to  $C_2$ . When the sterile barrier 190 is removed from the touch-sensitive display 1510, the capacitance detected by the pixels 1515 in clusters 1517 and 1517 returns to the capacitance to below  $C_2$ , but above or equal to  $C_1$ .

**[0355]** Returning to FIG. 182, the touch-sensitive display 1510 is alternatively a resistance-sensitive display. In at least one such embodiment, the sterile barrier 190 is comprised of a flexible material to allow the sterile barrier 190 to deflect in response to a force  $F$  applied by the input device 1530. In such an embodiment, the sensing mechanism 1513 of the touch-sensitive display 1510 is configured to detect the location

and pressure created from the force  $F$  applied by the input device 1530. Various user commands are associated with specific locations on the touch-sensitive display 1510, and the location of the detected pressure will correspond with one of the various user commands.

**[0356]** Referring to FIG. 24, a surgical instrument 2400 comprises a display 2430. The stapling instrument 2400 is similar to the stapling instruments 2000 and 2200 in many respects and the display 2430 is similar to the displays 2130 and 2230 in many respects, most of which will not be discussed herein for the sake of brevity. The display 2430 comprises a touchscreen including an image display 2435. The image display 2435 provides an image of the patient tissue  $T$  that is to be stapled. The user of the stapling instrument 2400 can use a stylus 2220, for example, to draw one or more potential staple lines over the tissue  $T$ . For instance, the user can draw a first staple line 2444 and a second staple line 2444'. The controller of the stapling instrument 2400 can then require the user to choose between the two different staple lines 2444 and 2444' that is to be followed. Similarly, the user of the stapling instrument 2400 can use the stylus to modify a staple line 2444 into an alternate staple line 2444'.

**[0357]** Referring again to FIG. 24, the image of the tissue  $T$  can be a substantially two-dimensional image of the top of the tissue  $T$ . In such instances, the controller is configured to map a two-dimensional staple firing path over the tissue  $T$ . Referring to FIG. 25, the image of the tissue  $T$  can be a three-dimensional image looking over the surface of the tissue  $T$ . In such instances, the controller is configured to map a three-dimensional staple firing path over the tissue  $T$ . In either event, the stylus 2220 and/or the patient's finger can be used to establish and/or modify the staple firing path.

Referring now to FIGS. 26 and 27, the stapling instrument 2400 further comprises a joystick 2450 configured to modify the staple firing path 2444 of the stapling instrument 2400. The joystick 2450 is mounted to the handle of the stapling instrument 2400 and is rotatable about an axis. When the joystick 2450 is rotated to the right, or in a clockwise direction, the staple firing path 2444 is curved to the right. Correspondingly, the staple firing path 2444 is curved to the left when the joystick 2450 is rotated to the left, or in a counter-clockwise direction. Other arrangements of a joystick are possible.

**[0358]** Referring again to FIGS. 26 and 27, the joystick 2450 can be used to modify the staple firing path of the stapling instrument 2400 while the stapling instrument 2400 is paused, or not firing staples. The joystick 2450 can also be used by the clinician to steer the stapling instrument 2400 in real-time while the stapling instrument 2400 is firing staples. In various instances, at least a portion of the stapling instrument 2400 is visible on the display 2430 to assist the user in steering the stapling instrument 2400. For instance, a shaft 2410 of the stapling instrument 2400 is visible in the image display 2435. In various instances, a graphically-created depiction of the stapling instrument 2400 can be provided in one or more windows of the display 2430. For instance, the shaft 2410 and/or distal head 2420 of the stapling instrument 2400 can be depicted in the windows 2133 and 2134, for example.

**[0359]** As described above, referring now to FIG. 23, the stapling instrument 2100 comprises a handle 2110 including a grip 2120 and a display 2130 mounted on the handle 2110. The display 2130 can comprise any suitable configuration, but the size of the display 2130 may be limited owing to the space constraints of the handle 2110. In various instances, the stapling instrument 2100 can be part of a surgical system 2300 which includes an off-board display 2330 in addition to or in lieu of the on-board display 2130. The controller of the stapling instrument 2100 is in signal communication with the displays 2130 and 2330. The controller is in wireless communication with the off-board display 2330, but could be in wired communication with the display 2330. In either event, the controller is configured to provide the same information to the displays 2130 and 2330. That said, the displays 2130 and 2330 can be configured to arrange this information in different ways owing to their different sizes and/or shapes. In other instances, one of the displays 2130 and 2330 can display more information than the other. In at least one such instance, the off-board display 2330 can display more information than the on-board display 2130 owing to its larger size, for example.

**[0360]** Further to the above, the on-board display 2130 comprises a touchscreen, but could be operated by controls positioned on the handle 2110. Similarly, the off-board display 2330 also comprises a touchscreen, but could be operated by other controls. Similar to the above, the touchscreens of the displays 2130 and 2330 can be used to manipulate the staple firing path of the stapling instrument 2100. In various instances, a

clinician can use their finger to touch the touchscreens and drag the staple firing path of the stapling instrument 2100 into a new position, for example. In other instances, a tool, such as a stylus, for example, can be used to touch the touchscreens and manipulate the staple firing path. Moreover, both displays 2130 and 2330 are configured to control any other operation of the stapling instrument 2100.

**[0361]** When a first overlay, or layer, is modified on one of the displays 2130 and 2330, the controller of the stapling instrument 2100 modifies the first overlay on the other display. Similarly, when a second overlay, or layer, is modified on one of the displays 2130 and 2330, the controller of the stapling instrument 2100 modifies the second overlay on the other display. Moreover, the user of the stapling instrument 2100 can modify one overlay, or layer, on a display without modifying the other overlays, or layers, on the display or either display.

**[0362]** While the staple firing paths, and/or other images, projected in the on-board and off-board displays described above are very helpful to produce a desired staple firing path, a stapling instrument can include one or more projectors configured to display an image onto the patient tissue which can assist the user of the stapling instrument with producing a desired staple firing path. Referring to FIGS. 160 and 161, a stapling instrument 7400 comprises a shaft 7410, a distal head 7420, and a projector 7490 mounted to the distal head 7420. In at least one instance, the projector 7490 is clamped to the distal head 7420. The projector 7490 is configured to project an image I onto the stomach S of the patient P. The projector 7490 is sized and configured to be inserted into the patient through a trocar TC, but could be inserted into a patient through an open incision. The projector 7490 is positioned proximally with respect to an anvil 7460 of the distal head 7420, but distally with respect to an articulation joint rotatably connecting the distal head 7420 to the shaft 7410. As a result, the projector 7490, and the image it projects, moves with the distal head 7420.

**[0363]** Referring to FIG. 162, a stapling instrument 7500 comprises a shaft 7510, a distal head 7520, and an articulation joint 7570 rotatably connecting the distal head 7520 to the shaft 7510. The stapling instrument 7500 further comprises a projector 7590 extending alongside the shaft 7510. The projector 7590 comprises a flexible tube mounted to the shaft 7510 and the distal head 7520 and is configured to bend when the

distal head 7520 is articulated. As a result, the image I projected by the projector 7590 tracks the orientation of the distal head 7520 and can be projected distally with respect to an anvil 7560 of the stapling instrument 7500. The projector 7590 comprises one lens and is configured to project one image I; however, various alternative embodiments are envisioned in which a projector comprises more than one lens and/or can project more than one image onto the patient tissue.

**[0364]** Referring again to FIG. 160, the projector 7490 comprises a first lens 7492 and a second lens 7494. The first lens 7492 and the second lens 7494 are in signal communication with the controller of the stapling instrument 7400 and are configured to project at least one image onto the patient tissue. In certain instances, the first lens 7492 and the second lens 7494 project the same image. The first lens 7492 and the second lens 7494 are fixedly mounted in the projector 7490 such that they project the image at a common focal point, although they could project an image, or images, at different focal points. In various embodiments, the orientation of the first lens 7492 and/or the orientation of the second lens 7494 can be adjusted to alter the focal point. In at least one such embodiment, the projector 7490 comprises a first motorized actuator system for changing the orientation of the first lens 7492 and a second motorized actuator system for changing the orientation of the second lens 7494.

**[0365]** In certain instances, further to the above, the first lens 7492 of the projector 7490 can be configured to project a first image onto the patient tissue and the second lens 7494 can be configured to project a second, or different, image onto the patient tissue. The controller of the stapling instrument 7400 is configured to supply, change, and/or alter the image projected by the first lens 7492 and/or the second lens 7494. In various instances, the images projected by the first lens 7492 and the second lens 7494 can provide a two-dimensional image on the patient tissue. In other instances, the images projected by the first lens 7492 and the second lens 7494 can provide a three-dimensional image on the patient tissue. Projecting a three-dimensional image can be facilitated by the lenses 7492 and 7494 being oriented, or orientable, in different directions.

**[0366]** Referring to FIG. 165, a stapling instrument 7700 comprises a distal head 7720 positioned on a first side of the patient tissue T and an anvil 7760 positioned on a

second side of the patient tissue T. Similar to the other stapling instruments disclosed herein, the stapling instrument 7700 is configured to deploy staples 7730 into the tissue T and incise the tissue T along an incision 7740 during a series of staple firing strokes. The stapling instrument 7700 further comprises a projector 7770 configured to project an image I onto the tissue T. The image I in FIG. 165 represents the location of the next firing stroke including two lateral areas in which staple clusters will be applied. Referring to FIG. 166, an image projected by the projector 7770 comprises a line designating the staple firing path FP and/or a line designating an alternate staple firing path FP'. These lines can be solid lines and/or dashed lines, for example. The lines can be the same color or different colors.

**[0367]** Further to the above, the controller of the stapling instrument 7700 is configured to modify the image projected by the projector 7770 as the stapling instrument 7700 moves, or marches, along a staple firing path. The controller can continuously evaluate and determine where the next firing stroke should occur and also continuously adapt the image projected by the stapling instrument 7700. In various instances, the controller can update the projected image after each firing stroke, for example. In some instances, the controller can continuously project an image, or a series of images, using the projector 7770 while, in other instances, the controller can intermittently project an image, or a series of images, using the projector 7770. In at least one instance, the controller can use the projector 7770 to display an image before the stapling instrument 7700 clamps the tissue. In such instances, the user of the stapling instrument 7700 is afforded an opportunity to pause or stop the stapling instrument 7700 before it makes another staple firing stroke.

**[0368]** Referring to FIG. 167, a stapling instrument 7800 comprises a distal head 7820 positioned on a first side of the patient tissue T and an anvil 7860 positioned on a second side of the patient tissue T. Similar to the other stapling instruments disclosed herein, the stapling instrument 7800 is configured to deploy staples 7830 into the tissue T and incise the tissue T along an incision 7840 during a series of staple firing strokes. The stapling instrument 7800 further comprises a projector 7870 including a first lens 7872 and a second lens 7874. The first lens 7872 is configured to project a first image I<sub>1</sub> onto the patient tissue T and the second lens 7874 is configured to project a second

image  $I_2$  on the patient tissue T. The image  $I_1$  depicts the locations of the next staple clusters and the image  $I_2$  depicts the cutting path of the stapling instrument 7800, although any suitable images could be projected. The images  $I_1$  and  $I_2$  can be solid lines and/or dashed lines, for example. The image  $I_1$  can be the same color as the image  $I_2$  or a different color.

**[0369]** As discussed above, the stapling instruments disclosed herein can comprise at least one projector for projecting images onto the patient tissue and at least one camera for observing the patient tissue. Referring to FIGS. 163 and 164, a stapling instrument 7600 comprises a shaft, a distal head, and a video system. The video system comprises at least one image projector 7690 and a camera system 7670 comprising at least one camera, such as a first camera 7672 and a second camera 7674, for example, which are in communication with the controller. The first camera 7672 is pointed in a first direction and is focused on a first area F1 of the patient tissue and the second camera 7674 is pointed in a second direction and is focused on a second, or different, area F2 of the patient tissue. In various instances, the controller is configured to present both images on the surgical instrument display at the same time, or at different times such that the user can toggle between the images. In certain instances, the controller is configured to use the images from the first and second cameras 7672 and 7674 to generate a composite image and present the composite image on the surgical instrument display.

**[0370]** Further to the above, the first camera 7672 comprises a digital camera configured to supply a first digital video stream to the controller while the second camera 7674 comprises a digital camera configured to supply a second digital video stream. The camera system 7670 further comprises a first actuator system configured to move the first camera 7672 and/or a second actuator system configured to move the second camera 7674. In other embodiments, one or both of the orientations of the cameras 7672 and 7674 are fixed. In any event, the image I projected onto the patient tissue by the projector 7690 can be captured by the first camera 7672 and/or the second camera 7674 and is viewable by the user of the surgical instrument 7600 through the surgical instrument display.

**[0371]** Further to the above, the projector 7690, and/or any of the projectors disclosed herein, are configured to emit light at any suitable wavelength. In various instances, the projector 7690 emits visible light, infrared light, and/or ultraviolet light, for example. Among other things, visible light is useful for the clinician to see the color of the tissue when the visible light reflects off the tissue. Red or pink tissue indicates healthy, vascularized tissue while dark or black tissue may indicate unhealthy tissue. Also further to the above, the camera system 7670 is configured to capture visible light, infrared light, and/or ultraviolet light, for example. Infrared light indicates the presence of heat, such as from large blood vessels, for example. Ultraviolet light indicates the presence of blood, or bleeding, for example. In addition to or in lieu of the above, a projector can be configured to emit sound waves, subsonic waves, and/or ultrasonic waves and the surgical instrument can comprise one or more acoustic sensors configured to detect the waves which reflect off of the patient tissue and generate data which can be used by the controller to generate a three-dimensional profile of the patient tissue.

**[0372]** Referring to FIG. 142, the stapling instruments described herein are configured to repeatedly fire staples into the tissue of a patient, such as the patient's stomach S, for example. Many of the stapling instruments disclosed herein are self-driving, self-propelled, and/or self-steering in that they are sufficiently motorized such that they can follow and propel themselves along an intended, or modified, staple firing path FP while firing staples, such as staples 6630, for example, into the patient tissue. The staples are continuously ejected from the stapling instruments as the stapling instruments move along the staple firing path FP. In various instances, the staple firing system of a stapling instrument enters into a dwell between staple firing strokes while the stapling instrument is moved along the staple firing path. Such dwells, however, are part of the continuous operation of the stapling instrument. As discussed above, referring to FIG. 143, many of the stapling instruments described herein are configured to deploy a cluster of staples, such as staple clusters 6630', for example, during each staple firing stroke. Such staple clusters can include any suitable number of staples, but each of the staple clusters 6630' depicted in FIG. 143 comprise three staples 6630 and are deployed on both sides of a tissue incision 6640. In at least one exemplary

embodiment, seven staple clusters 6630' are deployed on each side of the tissue incision 6640 for each inch of the staple firing path. In such embodiments, 42 staples are deployed per inch, although any suitable number can be used. The stapling instrument can continue to deploy staples along the staple firing path without having to remove the stapling instrument from the patient so long as there are staples in the stapling instrument. In at least one instance, a stapling instrument can be used between 84 and 98 firings, for example, before having to be reloaded. Such firings can deploy between 504 and 588 staples, for example.

**[0373]** Further to the above, many of the stapling instruments disclosed herein can at least partially turn between staple firings. As a result, such stapling instruments can follow complex and/or non-linear staple firing paths. Referring to FIG. 174, previous stapling instruments were configured to deploy linear staple line portions 8230' comprised of staples 8230, for example. In order to turn the staple line within the tissue, an overlap region 8235' in staple line portions 8230' was created. Such an arrangement created a high density of staples 8230 in the overlap region 8235', thereby highly compressing the tissue in the overlap region 8235'. Moreover, the overlap region 8235' represents a sharp turn in the staple firing path, which could create potential leak paths in the staple line. Referring to FIG. 175, the stapling instruments disclosed herein can make much more gradual turns because they can turn after each firing stroke. For instance, a stapling instrument can turn after deploying each staple cluster 7930' and can do so without creating overlap between the staple clusters 7930'.

**[0374]** The stapling instruments disclosed herein can be used to perform any suitable surgical procedure. For instance, referring to FIG. 179, a stapling instrument disclosed herein can be used during a gastric bypass procedure to produce a stomach pocket SP and, thus, effectively reduce the size of the patient's stomach S. Owing to the systems of the stapling instruments disclosed herein, these stapling instruments can create a curved staple path 7930' which creates a curved stomach pocket SP. Previous stapling instruments, referring to FIG. 178, would generate a staple path including linear portions 8230' which formed a square stomach pocket SP, or a stomach pocket SP with a right angle corner. It is believed that the curved stomach pocket SP produced by the stapling

instruments disclosed herein will leak less than the linear stomach pockets SP produced by previous stapling instruments.

**[0375]** As described in greater detail herein, referring to FIG. 177, the stapling instruments disclosed herein can be used during a stomach reduction procedure to produce a stomach sleeve SS and, thus, effectively reduce the size of the patient's stomach S. Owing to the systems of the stapling instruments disclosed herein, these stapling instruments can create a curved staple path 7930' which creates a curved stomach sleeve SS. Previous stapling instruments, referring to FIG. 176, would generate a staple path including linear portions 8230' which formed a linear stomach sleeve SS, or a stomach sleeve SS with a right angle corner 8235'. It is believed that the curved stomach sleeve SS produced by the stapling instruments disclosed herein will leak less than the linear stomach sleeves SS produced by previous stapling instruments. Additional details for creating a stomach sleeve SS are illustrated in FIG. 151 wherein a staple firing path FP is used to cut the stomach sleeve SS from the patient's stomach S.

**[0376]** Further to the above, gastric bypass procedures and gastric sleeve procedures aid in weight loss and are used to treat severe obesity. Both procedures serve to drastically decrease the size of the stomach in order to limit food intake. Gastric bypass procedures involve creating a small section within the stomach for receiving food and blocking off the rest of the stomach. Among other things, restricting the size of the stomach serves to limit the amount of fat and calories absorbed into a patient's body. Gastric bypass procedures create a direct path from the small stomach section to the lower intestine. In such instances, as a result, this direct path eliminates the use of the upper intestine in digestion.

**[0377]** A gastric sleeve procedure involves creating a sleeve-like path from the esophagus, through the stomach, and to the upper intestine. Laparoscopic sleeve gastrectomy (LSG) is a type of gastric sleeve procedure which involves the transection and sealing off of a substantial portion of the stomach in order to create a small gastric reservoir, or pocket. Unlike a gastric bypass procedure, it has been found that a LSG procedure does not cause a decrease in the absorption of nutrients and/or eliminate the use of any portion of the intestines. A LSG procedure, however, still functions to

significantly reduce the size of the stomach in a patient. In such LSG procedures, a long, thin, and flexible member, i.e., a bougie, can be used as a measuring tool. More specifically, a bougie can be used to determine or define the size and shape of the stomach that becomes the gastric sleeve upon completion of the LSG procedure. A bougie B is depicted in FIGS. 30 and 32. Bougies are manufactured in a variety of sizes in order to accommodate different stomach sizes. The appropriate size of a bougie is often determined based on stomach size and the anticipated gastric sleeve size. During the beginning steps of a LSG procedure, a surgeon inserts the bougie through a patient's mouth, down the esophagus, and through the esophageal sphincter to ultimately reach the patient's stomach. Once the bougie reaches the patient's stomach, the bougie is placed so that the end of the bougie reaches the pyloric canal, which is the lower area of the stomach connected to the pylorus.

**[0378]** FIG. 28 illustrates various parts of the stomach anatomy involved during various steps of a LSG procedure. In particular, FIG. 28 illustrates the stomach before a bougie B is inserted into the stomach S during a LSG procedure. As seen in FIG. 28, the omentum O, which is a double layer of fatty tissue, is connected to the outer layer of the stomach S. The omentum O comprises two portions - the greater omentum and the lesser omentum. The greater omentum serves to store fat deposits and the lesser omentum connects the stomach S and the intestines to the liver. The stomach S comprises various areas of shadowing based on the tissue thickness of the stomach S. The tissue thickness of the stomach S creates a first shadow  $S_{1a}$  and a second shadow  $S_{1b}$ . The size and location of the shadows  $S_{1a}$  and  $S_{1b}$  vary based on the thickness of the stomach S. As further illustrated in FIG. 28, the first shadow  $S_{1a}$  appears along the greater curvature GC of the stomach S and the second shadow  $S_{1b}$  appears along the lesser curvature LC of the stomach S. As discussed in greater detail below, the shadows  $S_{1a}$  and  $S_{1b}$  are used to determine, or estimate, the thickness of the stomach S along the greater curvature GC and the lesser curvature LC, respectively. Once the thickness of the stomach S is determined, or estimate, it is used to determine the appropriate size and placement of the bougie B in relation to the calculated shading lines  $S_L$  as seen in FIG. 28.

**[0379]** FIG. 33 illustrates another view of the stomach anatomy in accordance with various embodiments. Similar to the stomach anatomy depicted in FIG. 28, the tissue thickness of the stomach S creates a first shadow S<sub>1</sub> and a second shadow S<sub>2</sub>. Similar to the discussion above, the first shadow S<sub>1</sub> occurs along the greater curvature GC and the second shadow S<sub>2</sub> occurs along the lesser curvature LC. The first shadow S<sub>1</sub> and the second shadow S<sub>2</sub> intersect at a point S<sub>3</sub>. During a stomach sleeve procedure, the location of the pylorus P<sub>x</sub> and the point S<sub>3</sub> are used to determine the location of the cut line C<sup>1</sup> which is offset from the pylorus P<sub>x</sub> at a distance A. As illustrated in FIG. 33 and described in greater detail below, the sleeve diameter D is determined based on the estimated tissue thickness.

**[0380]** FIG. 152 illustrates various parts of the stomach which are involved during various steps of a LSG procedure. In particular, FIG. 152 illustrates the early steps of a LSG procedure wherein a bougie B is inserted into the stomach S. At the beginning of the LSG procedure, a surgeon inserts the bougie B through a patient's mouth, down the esophagus E, and through the esophageal sphincter to ultimately reach the patient's stomach. Once the bougie B reaches the patient's stomach, the bougie B is positioned so that the end of the bougie B rests in the pyloric canal PC and stops at the pyloric sphincter PS. As also illustrated in FIG. 152, the bougie B is configured to sit along the shape and length of the stomach S along the angular notch AN of the lesser curvature LC. As will be described in greater detail below with respect to FIG. 153, a bougie 7210 can be used which comprises magnetic properties which are configured to interact with and guide a stapling instrument 7100 along a predetermined path alongside the bougie 7210.

**[0381]** Referring again to FIG. 152, a distance D<sup>1</sup> is measured along the pyloric antrum PA of the greater curvature GC once the bougie is placed in its final position. The distance D<sup>1</sup> is used to determine the location of the pylorus P<sub>x</sub> and is used to determine the location of the cut line C<sup>1</sup>. The bougie 7210 illustrated in FIG. 153 creates one or more magnetic fields which are used to guide the stapling instrument 7100 to the bougie 7210. Thereafter, referring to FIG. 154, the stapling instrument 7100 follows the magnetic fields along a path adjacent to the bougie 7210 in order to create the cut line C<sup>1</sup>. As a result, the cut line C<sup>1</sup> extends upward through the patient's

stomach S along the shape and curvature of both the stomach S and the bougie 7210. The cut line C<sup>1</sup> then continues upward through the patient's stomach S along the path adjacent to the bougie 7210 until reaching the Angle of His AH. As the cut line C<sup>1</sup> is established, the stapling instrument 7100 applies staples, such as staples 7130, for example, to the tissue along both sides of the cut line C<sup>1</sup>. The remaining portion of the stomach S still in communication with the esophagus is substantially the size and shape of the bougie 7210. A substantial portion of the stomach S, which begins at the pyloric antrum PA and ends at the Angle of His AH, is eliminated from involvement in the digestive process. The eliminated portion of the stomach S is shown in greater detail in FIG. 154 and includes the greater curvature GC of the stomach S.

**[0382]** In some instances, a clinician can estimate an appropriate staple firing path in the patient's stomach by observing certain anatomical markers on the stomach and/or at other locations within the surgical site. Referring to FIG. 152, the stapling instruments disclosed herein, such as the stapling instrument 7100, for example, are configured to sense anatomical markers within the patient to determine the appropriate staple firing path. Further to the above, the stapling instruments disclosed herein can comprise one or more cameras configured to sense, or detect, one or more anatomical markers and, also, a controller configured to calculate a staple firing path based on the detected anatomical markers. In at least one instance, the stapling instrument is configured to detect the lesser curve of the stomach and calculate a staple firing path in the stomach tissue which parallels, or at least substantially parallels, the lesser curve. Other anatomical markers of the patient's stomach that can be detected and used to determine the staple firing path include the angular notch, the esophageal sphincter, the angle of His, the pyloric sphincter, and/or the pyloric antrum, for example.

**[0383]** As discussed above, the lesser curve of the stomach can be used to determine the staple firing path. In various instances, however, the lesser curve is at least partially obscured by fat and/or connective tissue. That said, the lesser curve, the lesser omentum, and any overlap between the lesser curve and the lesser omentum, for example, can be visibly differentiated. More specifically, the uncovered stomach tissue has a first color, the lesser omentum has a second color which is different than the first color, and the overlap between the two has a third color which is different than the first

color and the second color. These colors are detectable by the stapling instruments to determine an appropriate staple firing path. In certain instances, the color of the stomach tissue under the lesser omentum creates a shadow which is detectable by the stapling instrument. Other methods can be used to determine the appropriate location for the staple firing path.

**[0384]** Further to the above, a stomach sleeve SS created during a gastric bypass procedure must have a sufficiently large enough digestion passage defined therein in order for food to pass there through. As a result, referring now to FIG. 29, the staple firing path through the patient's stomach S must be sufficiently spaced from the lesser curve of the stomach to create a sufficient digestion passage D. The stapling instruments disclosed herein can be configured to detect the lesser curve of the stomach and calculate a staple firing path, such as staple firing path  $SP_1$ , for example, which is a distance X away from the edge of the stomach S. In other instances, the stapling instruments disclosed herein can be configured to detect the lesser omentum LO which borders the lesser curve of the stomach and calculate the staple firing path  $SP_1$ , for example, as a preset or predetermined distance X away from the edge of the stomach S.

**[0385]** As mentioned above, detecting the edge of the stomach S may be difficult. In certain instances, the stapling instruments disclosed herein can comprise a camera system configured to observe the color of the stomach tissue and/or changes in the stomach tissue color in order to determine the edge of the stomach S. In various instances, the stapling instruments disclosed herein can be configured to detect the edge of the stomach by evaluating the thickness of the stomach tissue and/or changes in the stomach tissue thickness. The tissue of a patient's stomach is typically thinner around the perimeter, or edge, of the stomach than in the middle of the stomach and it has been observed that the color of stomach tissue is often a function of its thickness. Stated another way, the tissue around the perimeter of the stomach seems to have a shadow, or darker, color owing to its thinner thickness. This shadow region  $S_1$  is demarcated by distance  $Z_1$  in FIG. 29. Distance  $Z_1$  also demarcates the transition from the thinner tissue to the full tissue thickness region  $T_1$  of the stomach S. In various instances, the surgical instruments disclosed herein can be configured to determine the

staple firing path  $SP_1$  by establishing the staple firing path  $SP_1$  a certain distance away from the shadow region  $S_1$ , for example. In at least one instance, the surgical instruments can establish the staple firing path  $SP_1$  a certain distance away from the midpoint between the lesser omentum LO and the edge of the shadow region  $S_1$ , for example.

**[0386]** Further to the above, the controller of the stapling instruments disclosed herein can comprise an edge detection algorithm. The edge detection algorithm is configured to sense a first light intensity at a first location and a second light intensity at a second location on the stomach tissue. The edge detection algorithm is further configured to calculate a first light intensity value for the first light intensity and a second light intensity value for the second light intensity and then compare the first light intensity value to the second light intensity value. The light intensity values can be on a scale between 1 and 100 where lower values represent darker tissue and higher values represent lighter tissue, for example. The first location and the second location establish a sample line along which additional samples can be taken to establish an intensity gradient. To this end, the edge detection algorithm is further configured to sense a third light intensity at a third location along the sample line, determine a third light intensity value at the third location, and compare the third light intensity value to the first light intensity value and the second light intensity value. The first location, the second location, and the third location are sequentially located along the sample line and, if the algorithm determines that the first light intensity value is larger than the second light intensity value and that the second light intensity value is larger than the third light intensity value, then the algorithm can determine that a shadow gradient exists between the first location and the third location and that the third location is closer to the edge of the stomach tissue than the first location, for example. This methodology can be applied on a very large scale to map the shadow gradient and/or color gradient of the entire stomach tissue, or at least a portion of the stomach tissue.

**[0387]** As discussed above, the thickness of the stomach tissue can affect the color or shadow of the stomach tissue. Thus, stomachs having thicker tissue (FIG. 29) will typically have different colors and/or shadows than stomachs having thinner tissue (FIG. 31). The thinner tissue in FIG. 31 has a shadow region  $S_2$  demarcated by distance  $Z_2$ .

Distance  $Z_2$  also demarcates the transition from the thinner tissue to the full tissue thickness region  $T_2$  of the stomach  $S_2$ . In various instances, the surgical instruments disclosed herein can be configured to determine the staple firing path  $SP_2$  by establishing the staple firing path  $SP_2$  a certain distance away from the shadow region  $S_2$ , for example. In at least one instance, the surgical instruments can establish the staple firing path  $SP_2$  a certain distance away from the midpoint between the lesser omentum  $LO_2$  and the edge of the shadow region  $S_2$ , for example.

**[0388]** The staple firing path  $SP_1$  establishes a first sleeve profile and the staple firing path  $SP_2$  establishes a second sleeve profile which is different than the first sleeve profile. The first sleeve profile comprises a first width  $X$  and the second sleeve profile comprises a second width  $Y$ , which is different than the width  $X$ . Regardless of the sleeve profile that is generated by a stapling instrument disclosed herein, the tissue drive system of the stapling instrument is configured to propel the stapling instrument along the staple firing path which creates the desired stomach sleeve. Such a stapling instrument can be configured to identify anatomical markers and steer itself toward, away from, and/or parallel to one or more anatomical markers.

**[0389]** Further to the above, referring to FIG. 153, the stapling instrument 7100 comprises a shaft 7110, a distal head 7120, and an articulation joint 7170 rotatably connecting the distal head 7120 to the shaft 7110. The stapling instrument 7100 is incise the patient's stomach along a path  $C1$  and apply three rows of staples 7130 on each side of the path  $C1$ . As described above, the bougie 7210 is configured to guide the stapling instrument 7100 along a staple firing path. More specifically, the bougie 7210 is configured to emit one or more magnetic fields which can be detected by the stapling instrument 7100 and then used by the stapling instrument 7100 to determine the staple firing path. In at least one instance, the bougie 7210 emits strong magnetic fields  $SMF$  and weak magnetic fields  $WMF$  which, when emitted, are emitted along the length of the bougie 7210. Notably, the weak magnetic fields  $WMF$  are positioned intermediate the strong magnetic fields  $SMF$  in an alternating manner.

**[0390]** Referring to FIG. 154, the stapling instrument 7100 comprises one or more sensors, such as Hall Effect sensors, for example, which are configured to detect the strong magnetic fields  $SMF$  and the weak magnetic fields  $WMF$ . The sensors are in

communication with the controller of the stapling instrument 7100 which can use data from the sensors to detect the arrangement of the strong magnetic fields SMF and weak magnetic fields WMF and align the staple firing path with the fields SMF and WMF such that the stapling instrument 7100 follows the bougie 7210 to create the desired stomach sleeve profile. In at least one instance, the intensity of the strong magnetic fields SMF is twice as intense as the weak magnetic fields WMF, for example. In other instances, the intensity of the strong magnetic fields SMF is 50% more intense than the intensity of the weak magnetic fields WMF, for example.

**[0391]** Referring to FIGS. 155 and 157, the bougie 7210 comprises an inner flexible core 7212 and a plurality of conductor windings configured to emit the magnetic fields SMF and WMF discussed above. The flexible core 7212 is comprised of a non-conductive material, or an at least substantially non-conductive material, such as rubber, for example. The flexible core 7212 is solid, but could comprise a tube. The conductor windings include winding circuits 7214 which emit the weak magnetic fields WMF and winding circuits 7216 which emit the strong magnetic fields SMF. The winding circuits 7214 have less windings than the winding circuits 7216 and produce weaker magnetic fields than the winding circuits 7216 for a given current. Each winding circuit 7214 comprises a conductive wire that is wrapped around the inner flexible core 7212 and is in communication with a controller of the bougie 7210. Each winding circuit 7214 is separate and distinct from the other winding circuits 7214 and, moreover, separate and distinct from the winding circuits 7216. Similarly, each winding circuit 7216 is separate and distinct from the other winding circuits 7216 and, moreover, separate and distinct from the winding circuits 7214. Each conductive wire comprises an inner conductive core and an insulative jacket extending around the conductive core. In an alternative embodiment, the conductive wires comprise conductive cores embedded in the flexible core 7212. In either event, the bougie 7210 comprises an outer jacket 7218 which is configured to seal the contents therein to prevent, or inhibit, the ingress of fluids into the bougie 7210.

**[0392]** In use, further to the above, a voltage source is applied to the winding circuits 7214 and 7216. The voltage applied to each winding circuit 7214 and 7216 is the same, or at least substantially the same. Alternatively, a first voltage is applied to the winding

circuits 7214 and a second, or different, voltage is applied to the winding circuits 7216. In various alternative embodiments, the winding circuits 7214 are not separate circuits; rather, they are part of one long circuit and a single current flows through each of the winding circuits 7214. Similarly, in various alternative embodiments, the winding circuits 7216 are not separate circuits; rather, they are part of one long circuit and a single current flows through each of the winding circuits 7216. In any event, the winding circuits 7214 and 7216 emit magnetic fields which extend around the entire perimeter of the bougie 7210 and, as a result, the bougie 7210 can be oriented, or rotated, in any suitable manner to perform the surgical procedure described above.

**[0393]** As described above, the bougie 7210 utilizes electricity to create magnetic fields. In various alternative embodiments, a bougie can comprise permanent magnets which create magnetic fields. In at least one instance, the bougie comprises strong permanent magnets which create a strong magnetic field and weak permanent magnets which create a weak magnetic field. In at least one such instance, the strong permanent magnets and the weak permanent magnets are arranged in an alternating manner to create the alternating strong magnetic fields SMF and weak magnetic fields WMF depicted in FIG. 154, for example. That said, a bougie can create one or more magnetic fields in any suitable manner.

**[0394]** Referring to FIG. 156, a bougie 7310 comprises an inner flexible core 7312 and a plurality of conductor windings configured to emit the magnetic fields SMF and WMF discussed above. The flexible core 7312 is comprised of a non-conductive material, or an at least substantially non-conductive material, such as rubber, for example. The conductor windings include winding circuits 7314 which are configured to emit the weak magnetic fields WMF and winding circuits 7316 which are configured to emit the strong magnetic fields SMF. The winding circuits 7314 have less windings than the winding circuits 7316 and will produce weaker magnetic fields than the winding circuits 7316, for a given current. Each winding circuit 7314 comprises a conductive wire that is wrapped around the inner flexible core 7312 and is in communication with a controller of the bougie 7310. The windings of the circuits 7314 are more compact, or dense, than the windings of the circuits 7214. For instance, the windings of the circuits 7214 extend longitudinally as they wrap around the core 7212 while the windings of the

circuits 7314 do not extend longitudinally, or at least not substantially so. Similarly, the windings of the circuits 7316 are more compact, or dense, than the windings of the circuits 7216. Dense or compact windings can create dense or compact magnetic fields which may be more discernable to the stapling instrument 7100, for example.

**[0395]** The surgical instrument systems described herein are motivated by an electric motor; however, the surgical instrument systems described herein can be motivated in any suitable manner. In certain instances, the motors disclosed herein may comprise a portion or portions of a robotically controlled system. U.S. Patent Application Serial No. 13/118,241, entitled SURGICAL STAPLING INSTRUMENTS WITH ROTATABLE STAPLE DEPLOYMENT ARRANGEMENTS, now U.S. Patent No. 9,072,535, for example, discloses several examples of a robotic surgical instrument system in greater detail.

**[0396]** The surgical instrument systems described herein have been described in connection with the deployment and deformation of staples; however, the embodiments described herein are not so limited. Various embodiments are envisioned which deploy fasteners other than staples, such as clamps or tacks, for example. Moreover, various embodiments are envisioned which utilize any suitable means for sealing tissue. For instance, an end effector in accordance with various embodiments can comprise electrodes configured to heat and seal the tissue. Also, for instance, an end effector in accordance with certain embodiments can apply vibrational energy to seal the tissue.

**[0397]** *Examples*

**[0398]** Example 1 - A surgical stapler for stapling the tissue of a patient comprising a handle, a shaft extending from the handle, and an end effector comprising a tissue compression surface, and an anvil comprising staple forming pockets, wherein the anvil is movable toward the tissue compression surface during a closing motion. The surgical stapler further comprises an anvil closing system configured to move the anvil through the closing motion and a propulsion system comprising a first foot configured to engage the patient tissue and move the end effector relative to the patient tissue during a first propulsion stroke and a second foot configured to engage the patient tissue and move the end effector relative to the patient tissue during a second propulsion stroke.

**[0399]** Example 2 - The surgical stapler of Example 1, wherein the propulsion system is configured to repetitively sequence the first propulsion stroke and the second propulsion stroke, whereby the propulsion system can walk the end effector relative to the patient tissue.

**[0400]** Example 3 - The surgical stapler of Examples 1 or 2, wherein the propulsion system is configured to complete the first propulsion stroke before beginning the second propulsion stroke.

**[0401]** Example 4 - The surgical stapler of Examples 1, 2, or 3, wherein the propulsion system is configured to at least partially complete the first propulsion stroke before beginning the second propulsion stroke.

**[0402]** Example 5 - The surgical stapler of Examples 1, 2, 3, or 4, wherein the propulsion system comprises means for synchronizing the first propulsion stroke and the second propulsion stroke.

**[0403]** Example 6 - The surgical stapler of Examples 1, 2, 3, 4, or 5, wherein the end effector further comprises a staple cartridge comprising a plurality of staples.

**[0404]** Example 7 - The surgical stapler of Example 6, further comprising a staple firing system configured to deploy the staples during a staple firing stroke.

**[0405]** Example 8 - The surgical stapler of Examples 1, 2, 3, 4, 5, 6, or 7, wherein the propulsion system comprises synchronizing means for performing the closing motion after the first propulsion stroke and the second propulsion stroke have both been performed.

**[0406]** Example 9 - The surgical stapler of Example 8, wherein the synchronizing means performs the staple firing stroke after the closure stroke has been performed.

**[0407]** Example 10 - The surgical stapler of Examples 8 or 9, wherein the synchronizing means includes a mechanism.

**[0408]** Example 11 - The surgical stapler of Examples 8, 9, or 10, wherein the synchronizing means comprises a controller including a microprocessor.

**[0409]** Example 12 - The surgical stapler of Examples 1, 2, 3, 4, 5, 6, 7, 8, 9, 10, or 11, wherein the propulsion system is configured to perform the first propulsion stroke and the second propulsion stroke at the same time.

**[0410]** Example 13 - The surgical stapler of Examples 1, 2, 3, 4, 5, 6, 7, 8, 9, 10, 11, or 12, wherein the propulsion system is configured to perform the first propulsion stroke to steer the end effector in a first direction and the second propulsion stroke to steer the end effector in a second direction.

**[0411]** Example 14 - The surgical stapler of Examples 1, 2, 3, 4, 5, 6, 7, 8, 9, 10, 11, 12, or 13, further comprising a vacuum system in communication with at least one of the first foot and the second foot, wherein the vacuum system is configured to hold the patient tissue within the end effector utilizing the vacuum system.

**[0412]** Example 15 - The surgical stapler of Examples 1, 2, 3, 4, 5, 6, 7, 8, 9, 10, 11, 12, 13, or 14, wherein the first foot comprises a first rotatable element and the second foot comprises a second rotatable element.

**[0413]** Example 16 - The surgical stapler of Examples 1, 2, 3, 4, 5, 6, 7, 8, 9, 10, 11, 12, 13, 14, or 15, wherein the first foot comprises a first set of teeth configured to grip the patient tissue and the second foot comprises a second set of teeth configured to grip the patient tissue.

**[0414]** Example 17 - The surgical stapler of Examples 1, 2, 3, 4, 5, 6, 7, 8, 9, 10, 11, 12, 13, 14, 15, or 16, wherein the first foot comprises a first translatable element and the second foot comprises a second translatable element.

**[0415]** Example 18 - The surgical stapler of Examples 1, 2, 3, 4, 5, 6, 7, 8, 9, 10, 11, 12, 13, 14, 15, 16, or 17, wherein the first foot comprises a first base and a first extendable portion which is extendable relative to the first base, and wherein the second foot comprises a second base and a second extendable portion which is extendable relative to the second base.

**[0416]** Example 19 - A surgical stapler for stapling the tissue of a patient comprising a handle, a shaft extending from the handle, and an end effector comprising a tissue compression surface and an anvil comprising staple forming pockets, wherein the anvil is movable toward the tissue compression surface during a closing motion. The surgical stapler further comprises an anvil closing system configured to move the anvil through the closing motion and a tissue advancement system comprising a foot configured to engage the patient tissue and pull the patient tissue relative to the end effector during a tissue advancement stroke.

**[0417]** Example 20 - A surgical stapler for stapling the tissue of a patient comprising a handle, a shaft extending from the handle, a plurality of staple cartridges, and an end effector comprising a tissue compression surface and an anvil comprising staple forming pockets, wherein the anvil is movable toward the tissue compression surface during a closing motion. The surgical stapler further comprises an anvil closing system configured to move the anvil through the closing motion, a staple firing system configured to deploy the staple cartridges along a path, and means for gripping the patient tissue and creating relative movement between the end effector and the patient tissue to re-position the end effector along the path.

**[0418]** The entire disclosures of:

- U.S. Patent No. 5,403,312, entitled ELECTROSURGICAL HEMOSTATIC DEVICE, which issued on April 4, 1995;
- U.S. Patent No. 7,000,818, entitled SURGICAL STAPLING INSTRUMENT HAVING SEPARATE DISTINCT CLOSING AND FIRING SYSTEMS, which issued on February 21, 2006;
- U.S. Patent No. 7,422,139, entitled MOTOR-DRIVEN SURGICAL CUTTING AND FASTENING INSTRUMENT WITH TACTILE POSITION FEEDBACK, which issued on September 9, 2008;
- U.S. Patent No. 7,464,849, entitled ELECTRO-MECHANICAL SURGICAL INSTRUMENT WITH CLOSURE SYSTEM AND ANVIL ALIGNMENT COMPONENTS, which issued on December 16, 2008;
- U.S. Patent No. 7,670,334, entitled SURGICAL INSTRUMENT HAVING AN ARTICULATING END EFFECTOR, which issued on March 2, 2010;
- U.S. Patent No. 7,753,245, entitled SURGICAL STAPLING INSTRUMENTS, which issued on July 13, 2010;
- U.S. Patent No. 8,393,514, entitled SELECTIVELY ORIENTABLE IMPLANTABLE FASTENER CARTRIDGE, which issued on March 12, 2013;
- U.S. Patent Application Serial No. 11/343,803, entitled SURGICAL INSTRUMENT HAVING RECORDING CAPABILITIES, now U.S. Patent No. 7,845,537;
- U.S. Patent Application Serial No. 12/031,573, entitled SURGICAL CUTTING AND FASTENING INSTRUMENT HAVING RF ELECTRODES, filed February 14, 2008;

- U.S. Patent Application Serial No. 12/031,873, entitled END EFFECTORS FOR A SURGICAL CUTTING AND STAPLING INSTRUMENT, filed February 15, 2008, now U.S. Patent No. 7,980,443;
- U.S. Patent Application Serial No. 12/235,782, entitled MOTOR-DRIVEN SURGICAL CUTTING INSTRUMENT, now U.S. Patent No. 8,210,411;
- U.S. Patent Application Serial No. 12/249,117, entitled POWERED SURGICAL CUTTING AND STAPLING APPARATUS WITH MANUALLY RETRACTABLE FIRING SYSTEM, now U.S. Patent No. 8,608,045;
- U.S. Patent Application Serial No. 12/647,100, entitled MOTOR-DRIVEN SURGICAL CUTTING INSTRUMENT WITH ELECTRIC ACTUATOR DIRECTIONAL CONTROL ASSEMBLY, filed December 24, 2009, now U.S. Patent No. 8,220,688;
- U.S. Patent Application Serial No. 12/893,461, entitled STAPLE CARTRIDGE, filed September 29, 2012, now U.S. Patent No. 8,733,613;
- U.S. Patent Application Serial No. 13/036,647, entitled SURGICAL STAPLING INSTRUMENT, filed February 28, 2011, now U.S. Patent No. 8,561,870;
- U.S. Patent Application Serial No. 13/118,241, entitled SURGICAL STAPLING INSTRUMENTS WITH ROTABLE STAPLE DEPLOYMENT ARRANGEMENTS, now U.S. Patent No. 9,072,535;
- U.S. Patent Application Serial No. 13/524,049, entitled ARTICULATABLE SURGICAL INSTRUMENT COMPRISING A FIRING DRIVE, filed on June 15, 2012, now U.S. Patent No. 9,101,358;
- U.S. Patent Application Serial No. 13/800,025, entitled STAPLE CARTRIDGE TISSUE THICKNESS SENSOR SYSTEM, filed on March 13, 2013, now U.S. Patent No. 9,345,481;
- U.S. Patent Application Serial No. 13/800,067, entitled STAPLE CARTRIDGE TISSUE THICKNESS SENSOR SYSTEM, filed on March 13, 2013, now U.S. Patent Application Publication No. 2014/0263552;
- U.S. Patent Application Publication No. 2007/0175955, entitled SURGICAL CUTTING AND FASTENING INSTRUMENT WITH CLOSURE TRIGGER LOCKING MECHANISM, filed January 31, 2006; and

- U.S. Patent Application Publication No. 2010/0264194, entitled SURGICAL STAPLING INSTRUMENT WITH AN ARTICULATABLE END EFFECTOR, filed April 22, 2010, now U.S. Patent No. 8,308,040, are hereby incorporated by reference herein.

**[0419]** Although various devices have been described herein in connection with certain embodiments, modifications and variations to those embodiments may be implemented. Particular features, structures, or characteristics may be combined in any suitable manner in one or more embodiments. Thus, the particular features, structures, or characteristics illustrated or described in connection with one embodiment may be combined in whole or in part, with the features, structures or characteristics of one or more other embodiments without limitation. Also, where materials are disclosed for certain components, other materials may be used. Furthermore, according to various embodiments, a single component may be replaced by multiple components, and multiple components may be replaced by a single component, to perform a given function or functions. The foregoing description and following claims are intended to cover all such modification and variations.

**[0420]** The devices disclosed herein can be designed to be disposed of after a single use, or they can be designed to be used multiple times. In either case, however, a device can be reconditioned for reuse after at least one use. Reconditioning can include any combination of the steps including, but not limited to, the disassembly of the device, followed by cleaning or replacement of particular pieces of the device, and subsequent reassembly of the device. In particular, a reconditioning facility and/or surgical team can disassemble a device and, after cleaning and/or replacing particular parts of the device, the device can be reassembled for subsequent use. Those skilled in the art will appreciate that reconditioning of a device can utilize a variety of techniques for disassembly, cleaning/replacement, and reassembly. Use of such techniques, and the resulting reconditioned device, are all within the scope of the present application.

**[0421]** The devices disclosed herein may be processed before surgery. First, a new or used instrument may be obtained and, when necessary, cleaned. The instrument may then be sterilized. In one sterilization technique, the instrument is placed in a closed and sealed container, such as a plastic or TYVEK bag. The container and

instrument may then be placed in a field of radiation that can penetrate the container, such as gamma radiation, x-rays, and/or high-energy electrons. The radiation may kill bacteria on the instrument and in the container. The sterilized instrument may then be stored in the sterile container. The sealed container may keep the instrument sterile until it is opened in a medical facility. A device may also be sterilized using any other technique known in the art, including but not limited to beta radiation, gamma radiation, ethylene oxide, plasma peroxide, and/or steam.

**[0422]** While this invention has been described as having exemplary designs, the present invention may be further modified within the spirit and scope of the disclosure. This application is therefore intended to cover any variations, uses, or adaptations of the invention using its general principles.

**[0423]** Any patent, publication, or other disclosure material, in whole or in part, that is said to be incorporated by reference herein is incorporated herein only to the extent that the incorporated materials do not conflict with existing definitions, statements, or other disclosure material set forth in this disclosure. As such, and to the extent necessary, the disclosure as explicitly set forth herein supersedes any conflicting material incorporated herein by reference. Any material, or portion thereof, that is said to be incorporated by reference herein, but which conflicts with existing definitions, statements, or other disclosure material set forth herein will only be incorporated to the extent that no conflict arises between that incorporated material and the existing disclosure material.

## WHAT IS CLAIMED IS:

1. A surgical stapler for stapling the tissue of a patient, comprising:
  - a handle;
  - a shaft extending from said handle;
  - an end effector, comprising:
    - a tissue compression surface; and
    - an anvil comprising staple forming pockets, wherein said anvil is movable toward said tissue compression surface during a closing motion;
    - an anvil closing system configured to move said anvil through said closing motion; and
    - a propulsion system, comprising:
      - a first foot configured to engage the patient tissue and move said end effector relative to the patient tissue during a first propulsion stroke; and
      - a second foot configured to engage the patient tissue and move said end effector relative to the patient tissue during a second propulsion stroke.
2. The surgical stapler of Claim 1, wherein said propulsion system is configured to repetitively sequence said first propulsion stroke and said second propulsion stroke, whereby said propulsion system can walk said end effector relative to the patient tissue.
3. The surgical stapler of Claim 1, wherein said propulsion system is configured to complete said first propulsion stroke before beginning said second propulsion stroke.
4. The surgical stapler of Claim 1, wherein said propulsion system is configured to at least partially complete said first propulsion stroke before beginning said second propulsion stroke.
5. The surgical stapler of Claim 1, wherein said propulsion system comprises means for synchronizing said first propulsion stroke and said second propulsion stroke.

6. The surgical stapler of Claim 1, wherein said end effector further comprises a staple cartridge comprising a plurality of staples.
7. The surgical stapler of Claim 6, further comprising a staple firing system configured to deploy said staples during a staple firing stroke.
8. The surgical stapler of Claim 7, wherein said propulsion system comprises synchronizing means for performing said closing motion after said first propulsion stroke and said second propulsion stroke have both been performed.
9. The surgical stapler of Claim 8, wherein said synchronizing means performs said staple firing stroke after said closure stroke has been performed.
10. The surgical stapler of Claim 9, wherein said synchronizing means includes a mechanism.
11. The surgical stapler of Claim 9, wherein said synchronizing means comprises a controller including a microprocessor.
12. The surgical stapler of Claim 1, wherein said propulsion system is configured to perform said first propulsion stroke and said second propulsion stroke at the same time.
13. The surgical stapler of Claim 1, wherein said propulsion system is configured to perform said first propulsion stroke to steer said end effector in a first direction and said second propulsion stroke to steer said end effector in a second direction.
14. The surgical stapler of Claim 1, further comprising a vacuum system in communication with at least one of said first foot and said second foot, wherein said vacuum system is configured to hold the patient tissue within said end effector utilizing said vacuum system.

15. The surgical stapler of Claim 1, wherein said first foot comprises a first rotatable element and said second foot comprises a second rotatable element.
16. The surgical stapler of Claim 1, wherein said first foot comprises a first set of teeth configured to grip the patient tissue and said second foot comprises a second set of teeth configured to grip the patient tissue.
17. The surgical stapler of Claim 1, wherein said first foot comprises a first translatable element and said second foot comprises a second translatable element.
18. The surgical stapler of Claim 1, wherein said first foot comprises a first base and a first extendable portion which is extendable relative to said first base, and wherein said second foot comprises a second base and a second extendable portion which is extendable relative to said second base.
19. A surgical stapler for stapling the tissue of a patient, comprising:
  - a handle;
  - a shaft extending from said handle;
  - an end effector, comprising:
    - a tissue compression surface; and
    - an anvil comprising staple forming pockets, wherein said anvil is movable toward said tissue compression surface during a closing motion;
    - an anvil closing system configured to move said anvil through said closing motion; and
    - a tissue advancement system comprising a foot configured to engage the patient tissue and pull the patient tissue relative to said end effector during a tissue advancement stroke.
20. A surgical stapler for stapling the tissue of a patient, comprising:
  - a handle;
  - a shaft extending from said handle;

a plurality of staple cartridges;  
an end effector, comprising:  
    a tissue compression surface; and  
    an anvil comprising staple forming pockets, wherein said anvil is movable toward said tissue compression surface during a closing motion;  
    an anvil closing system configured to move said anvil through said closing motion;  
    a staple firing system configured to deploy said staple cartridges along a path;  
and  
    means for gripping the patient tissue and creating relative movement between said end effector and the patient tissue to re-position said end effector along said path.

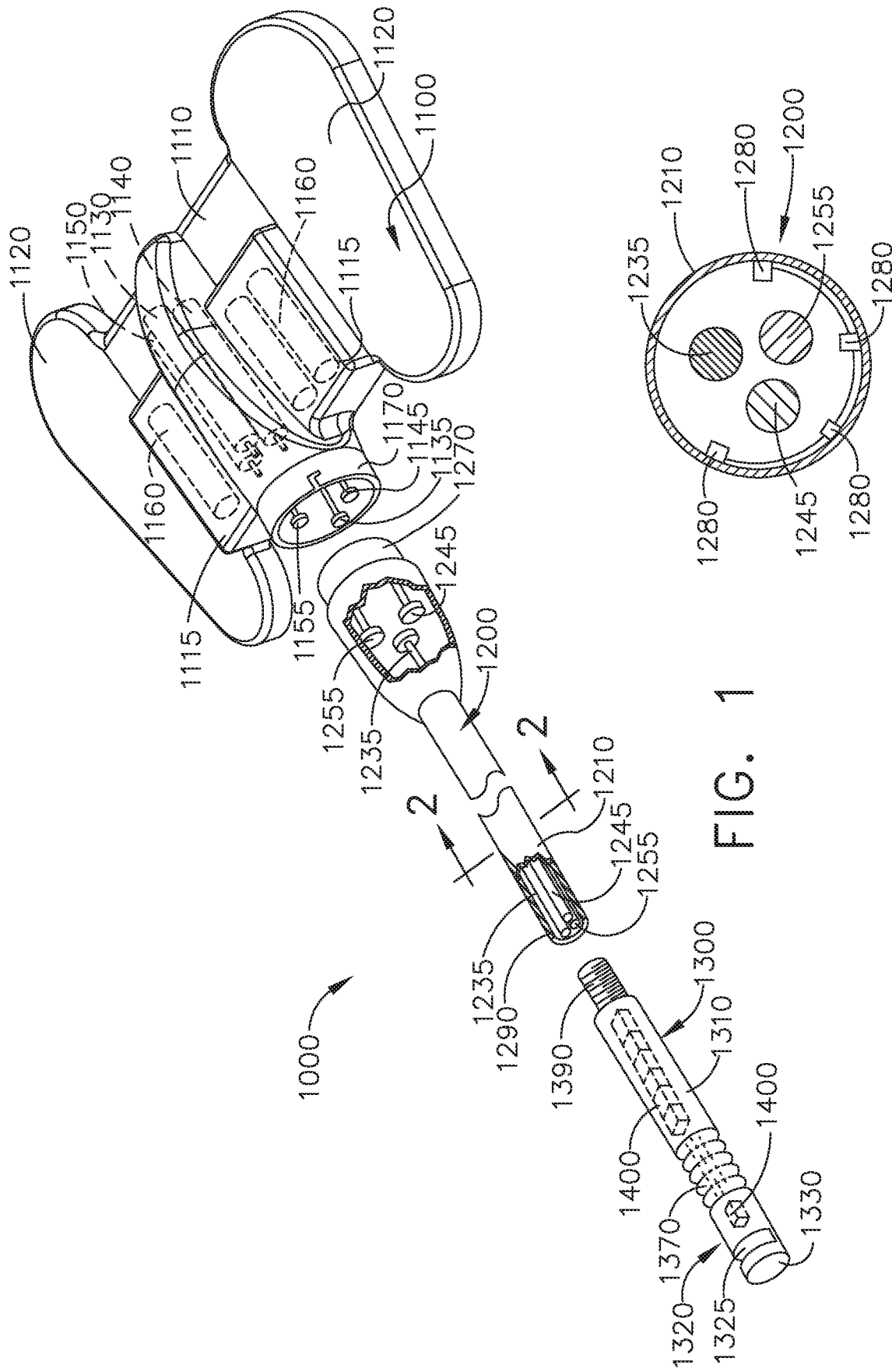

FIG. 2

FIG. 1

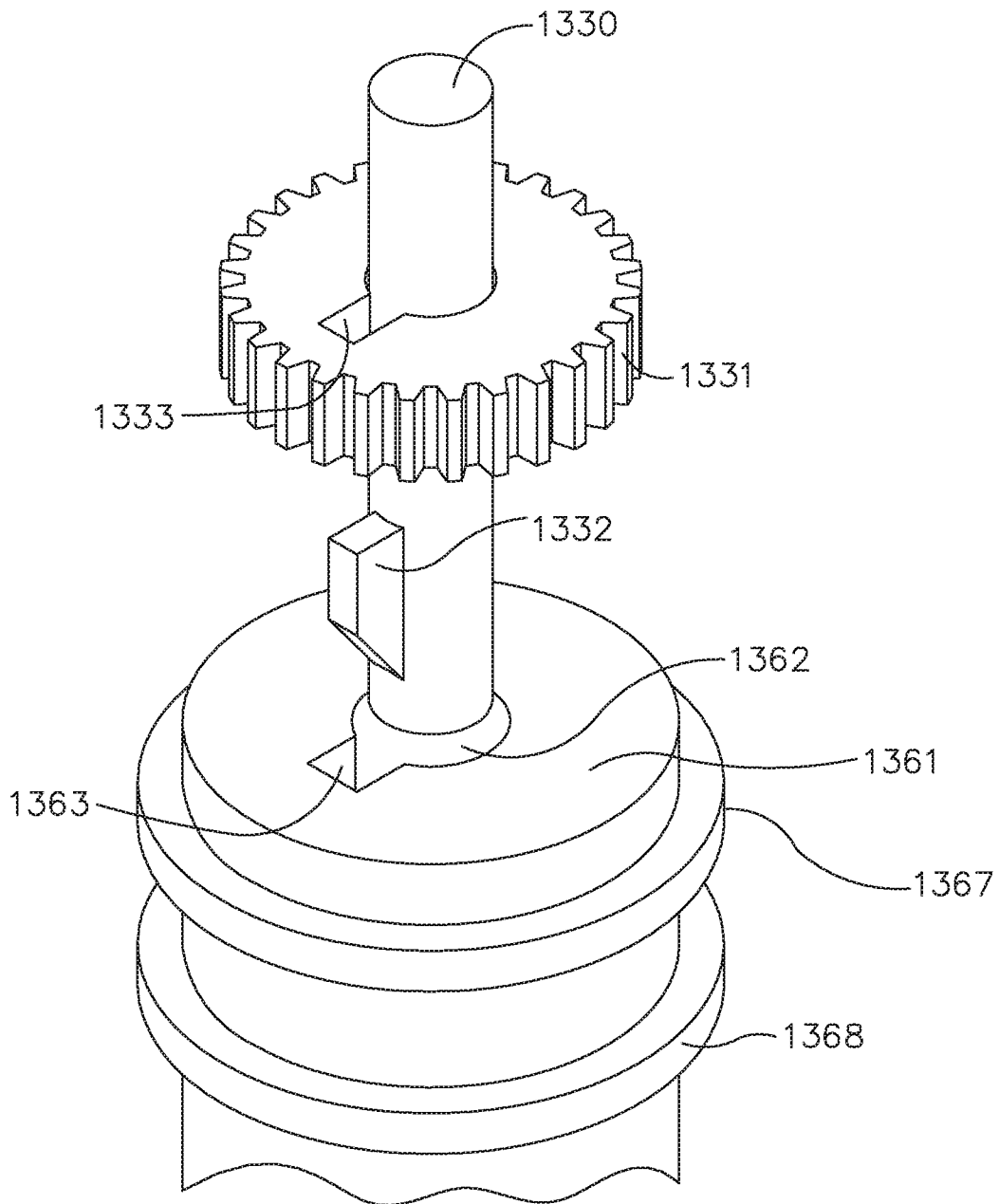

FIG. 3

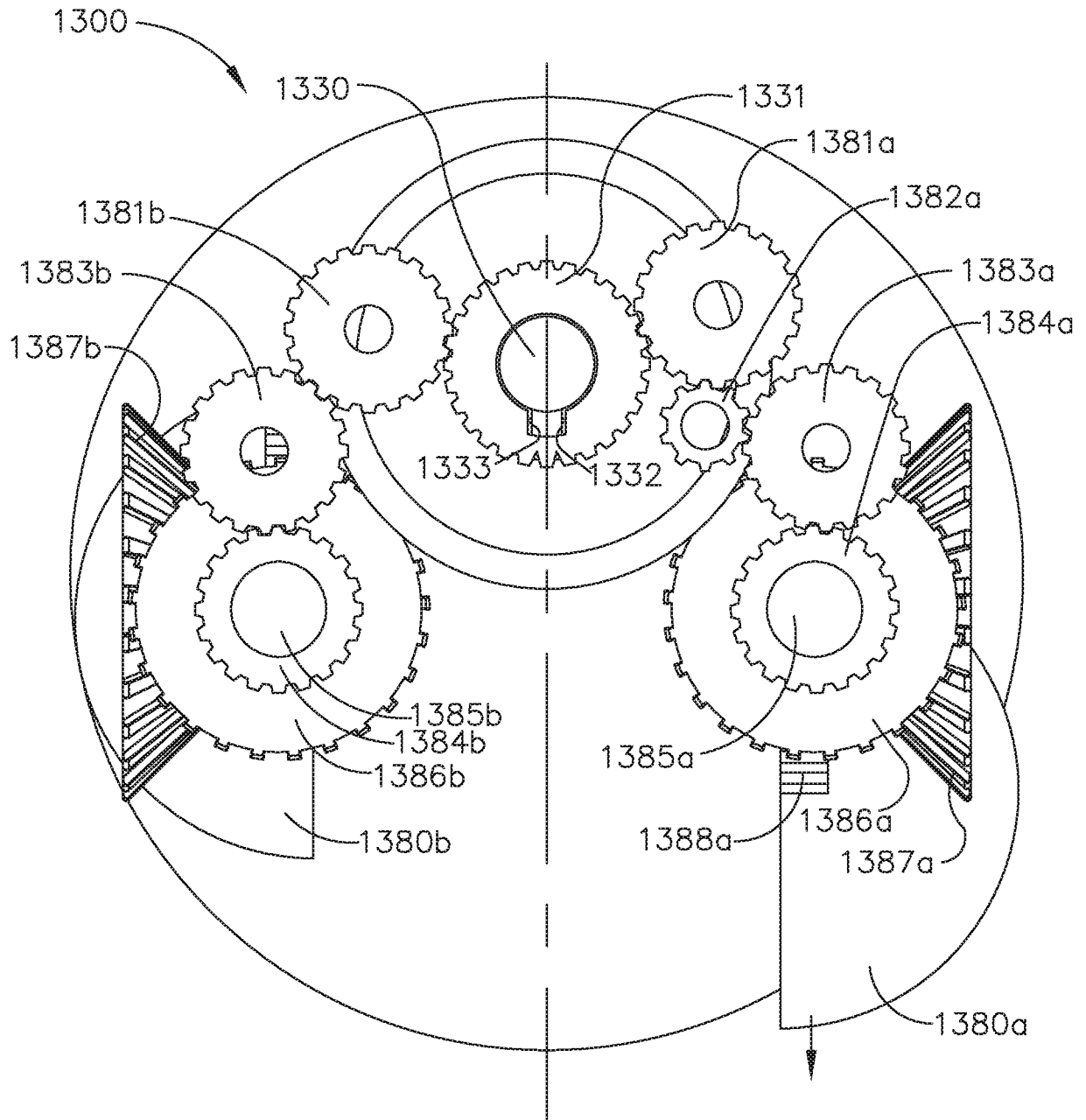

FIG. 4

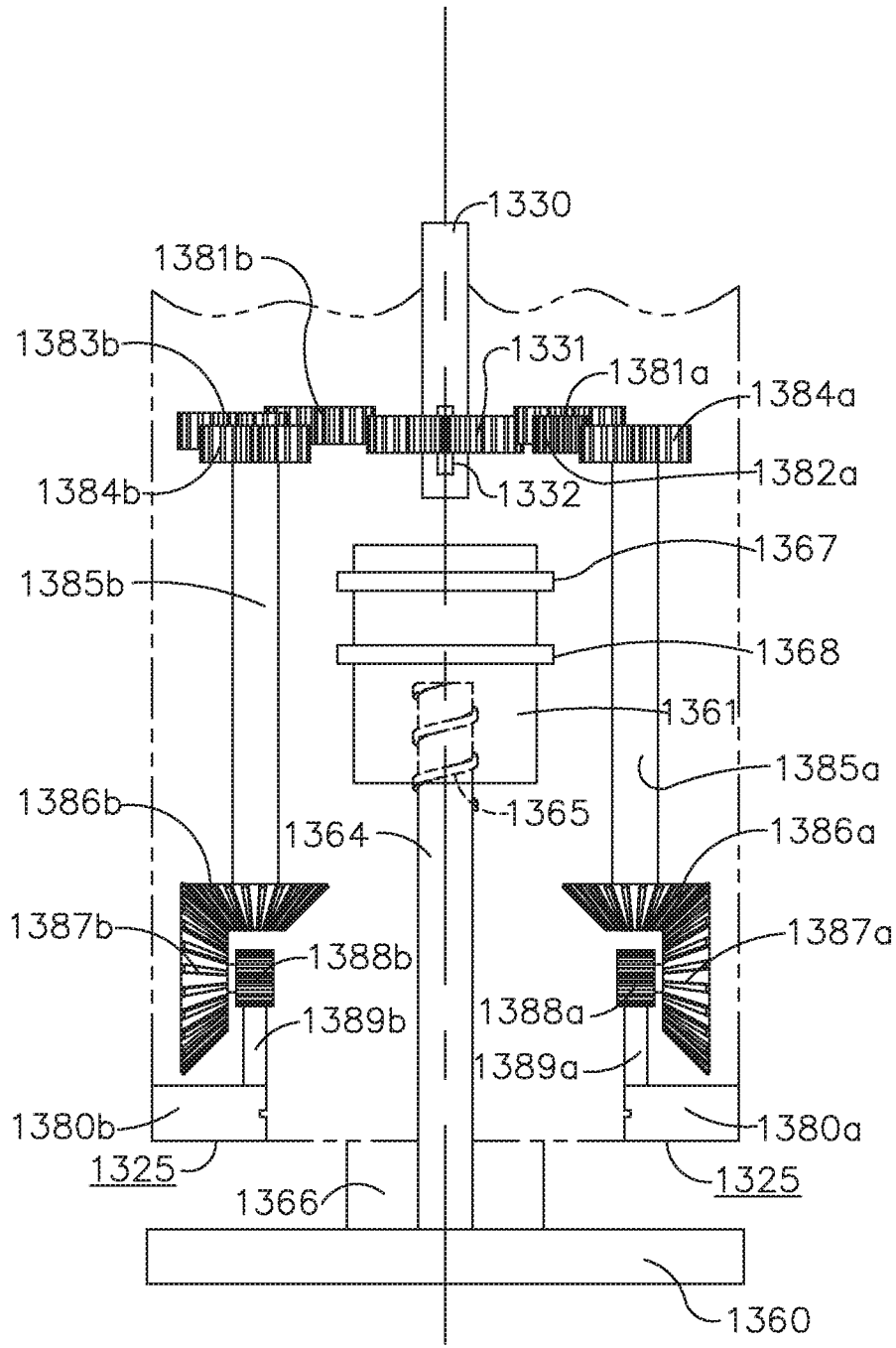

FIG. 5

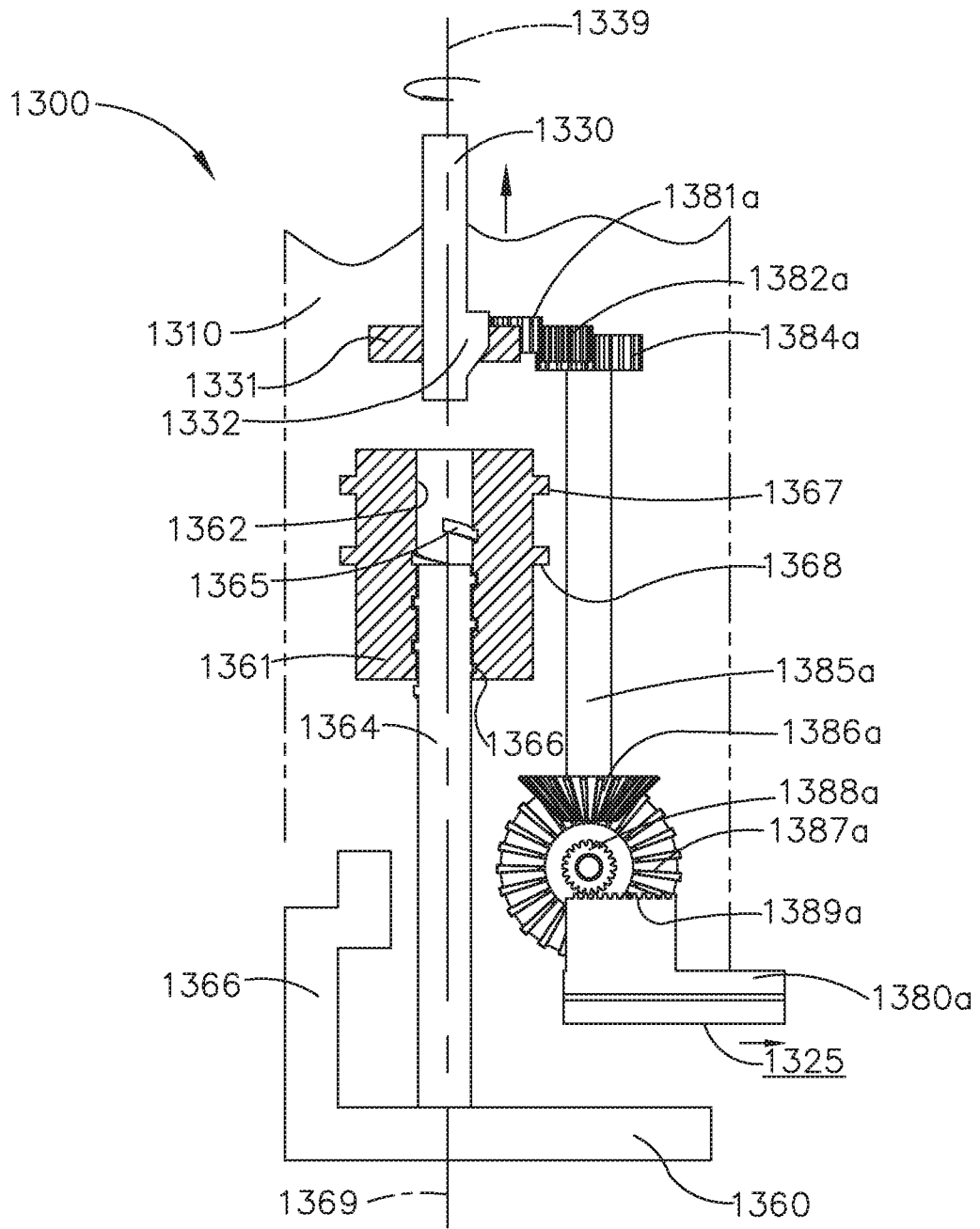

FIG. 6

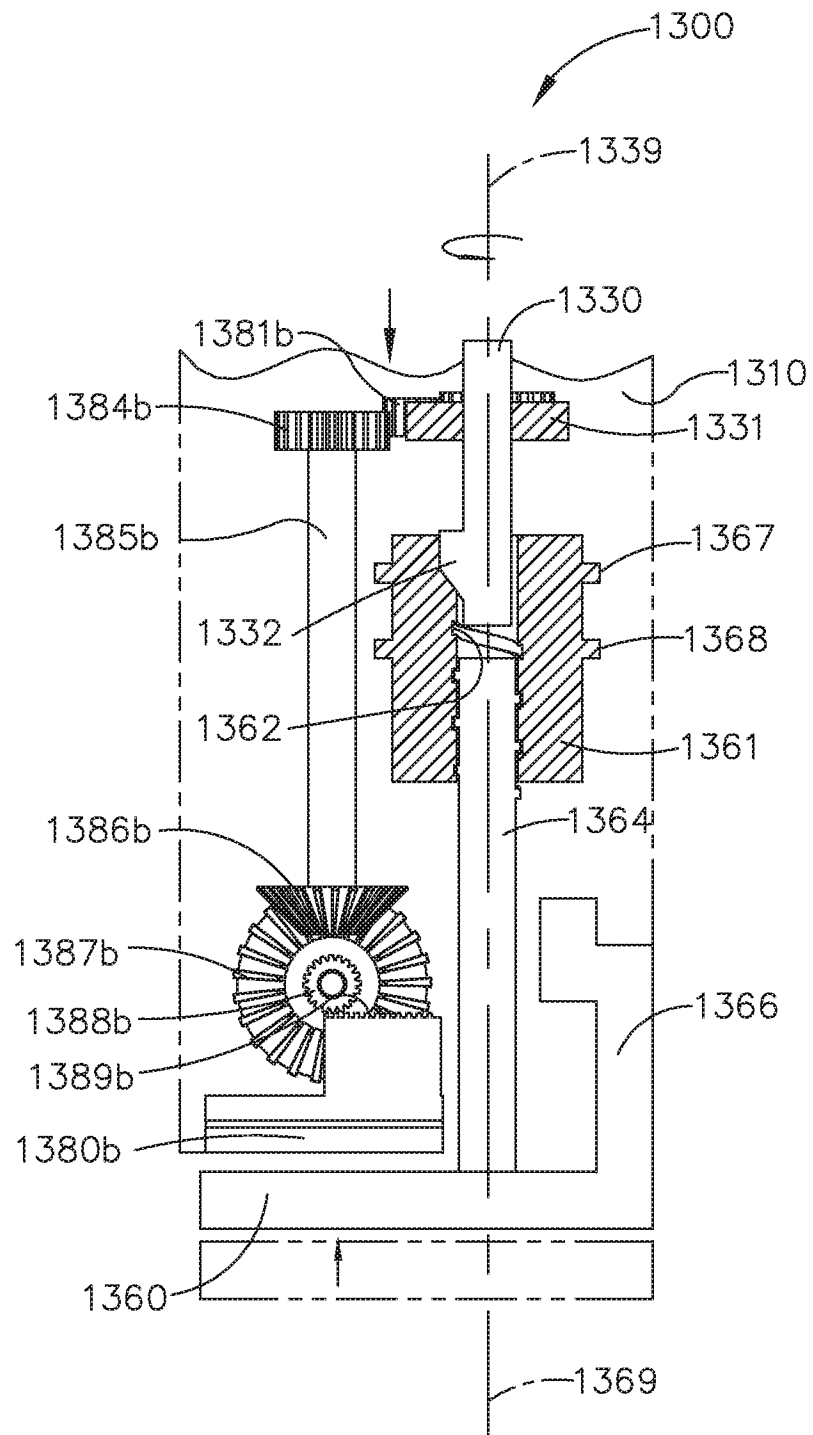

FIG. 7

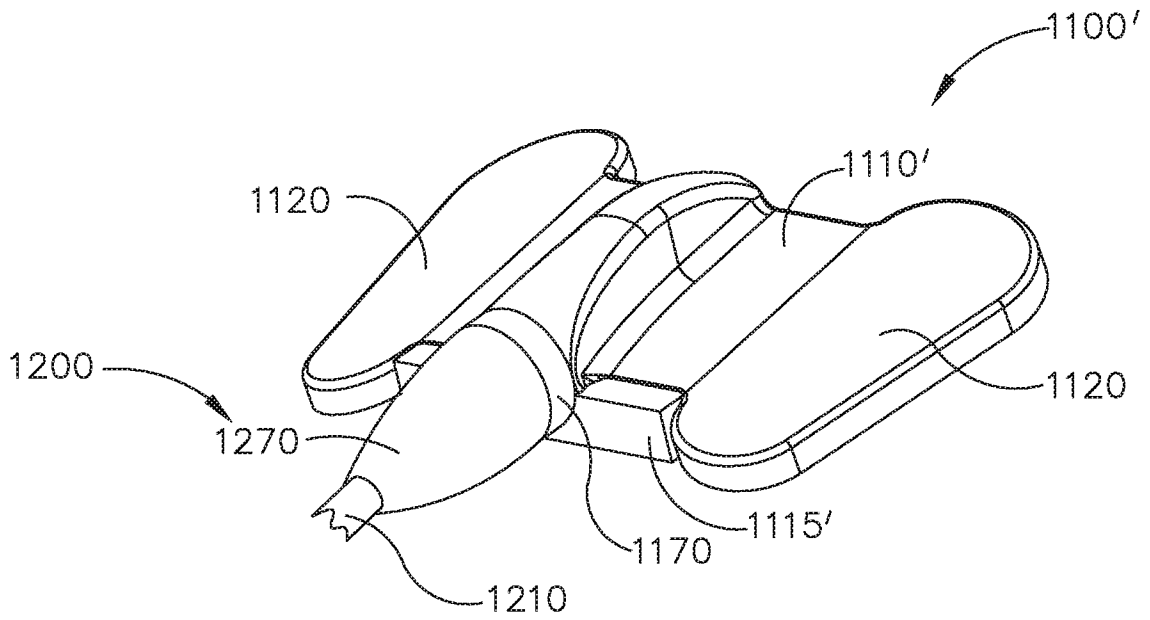

FIG. 8

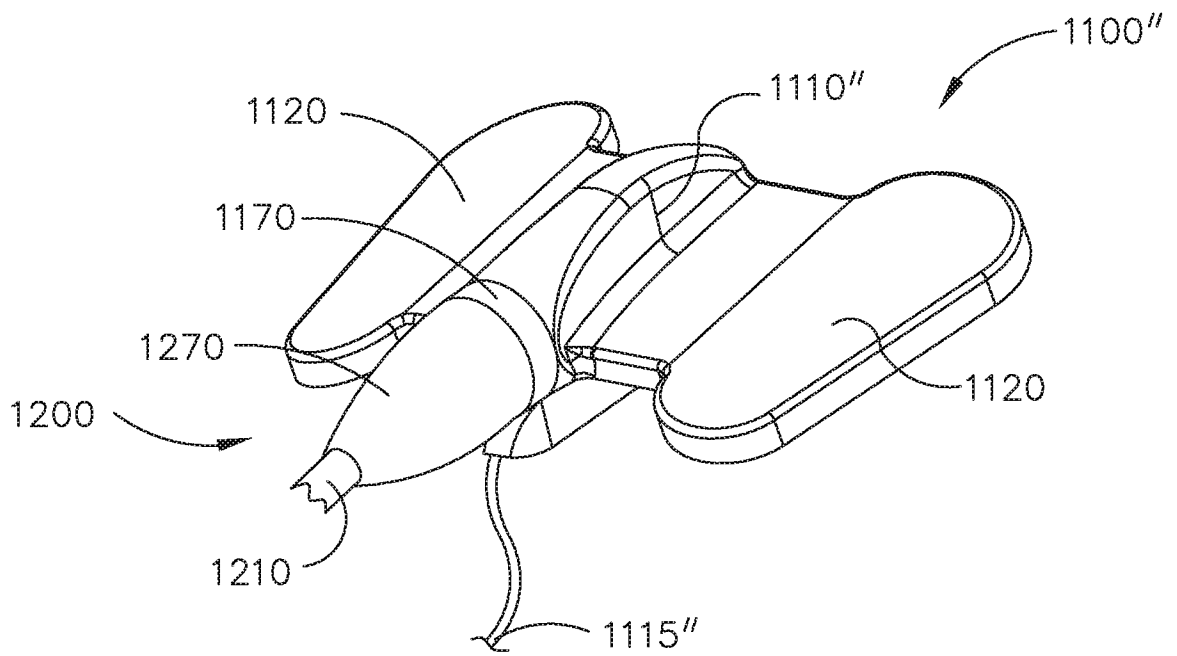

FIG. 9

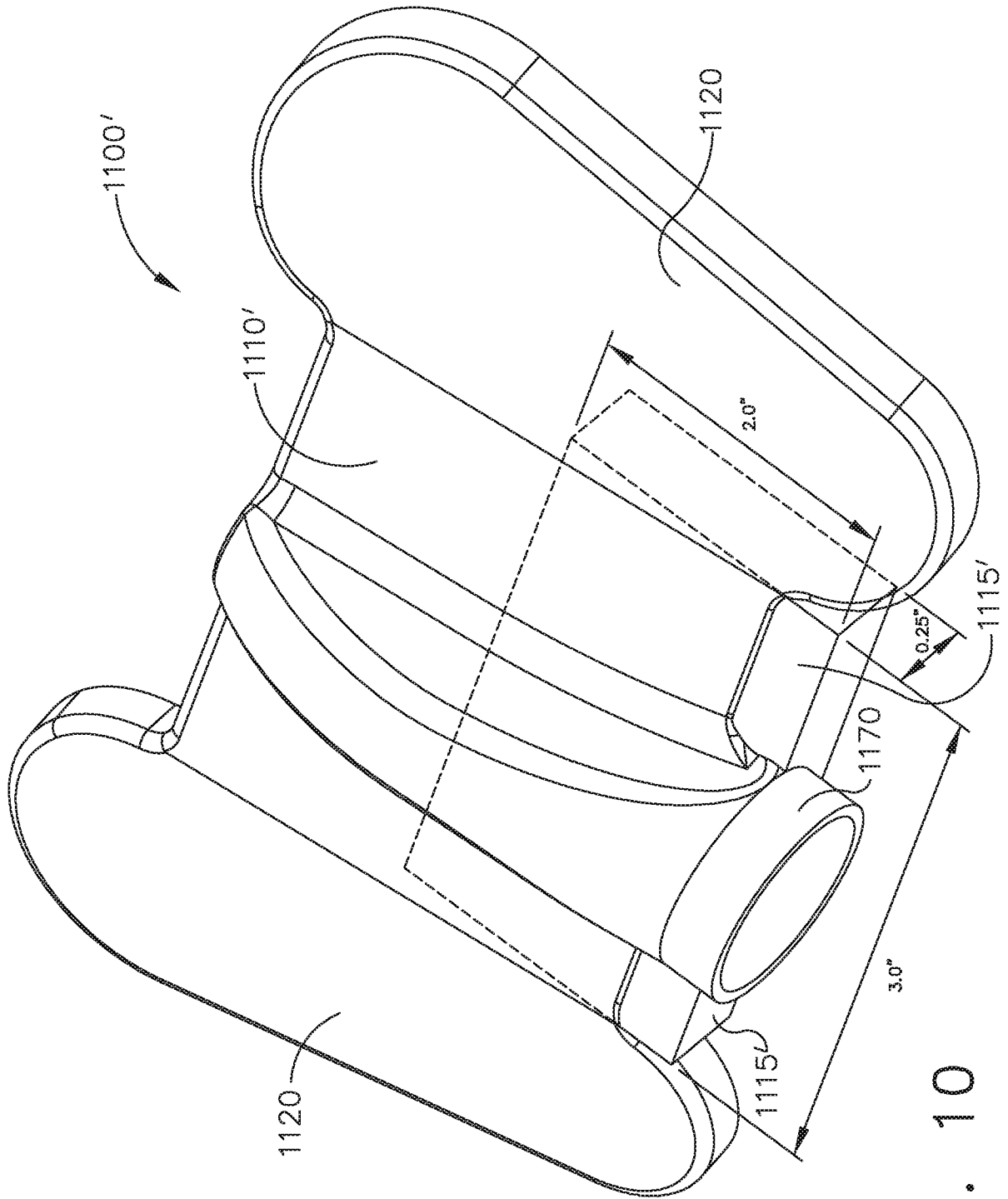

FIG. 10

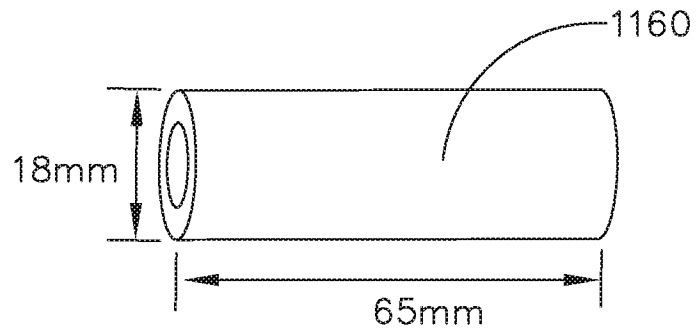

FIG. 11

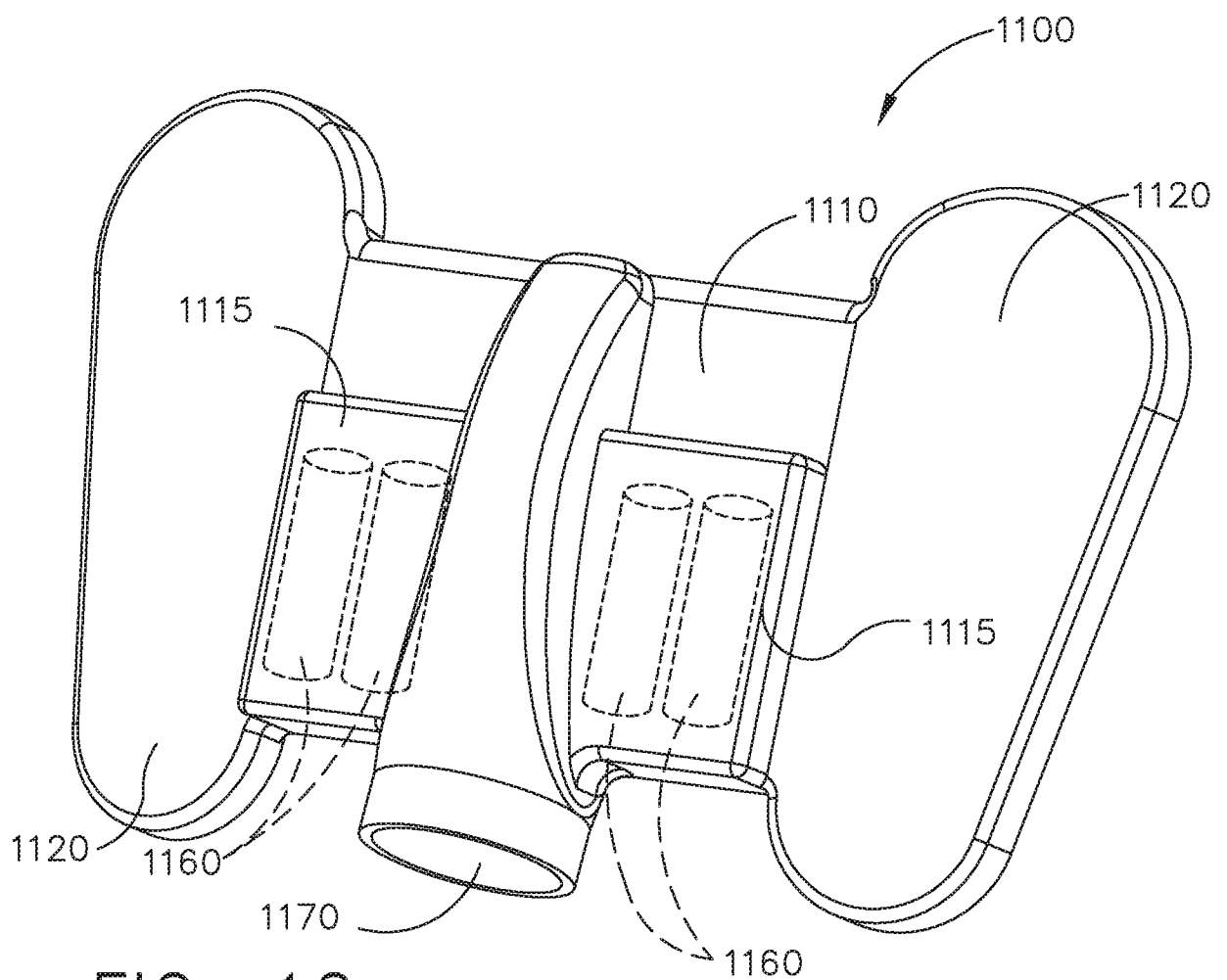

FIG. 12

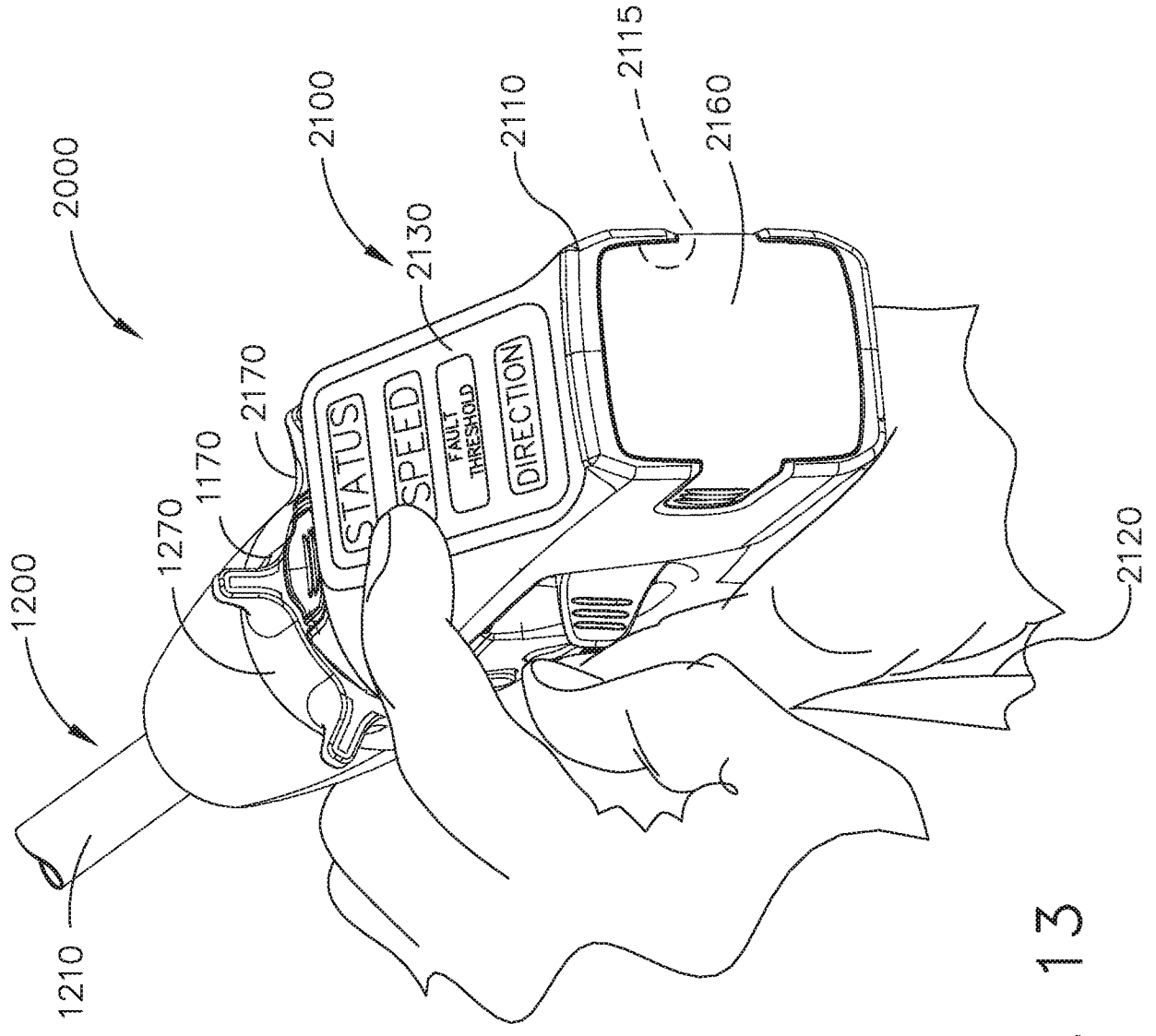

FIG. 13

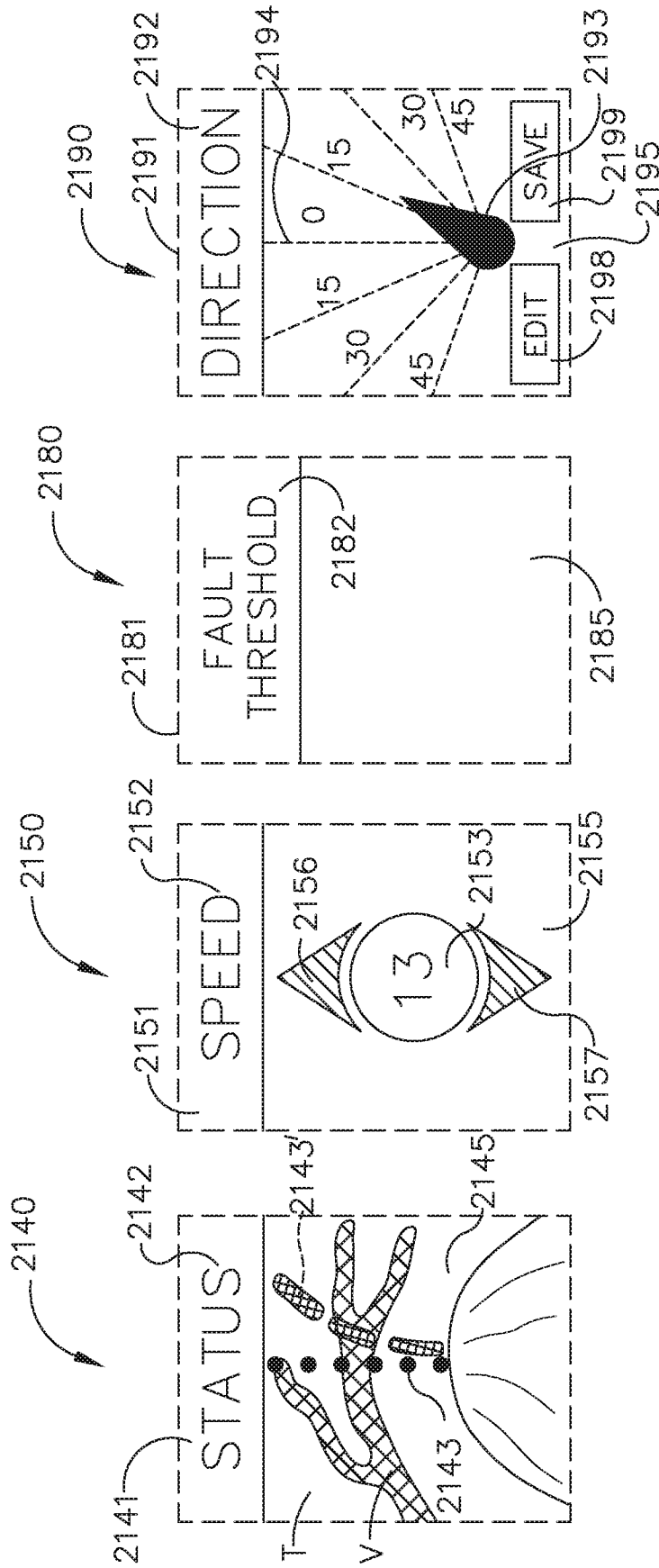

FIG. 14 FIG. 15 FIG. 16 FIG. 17

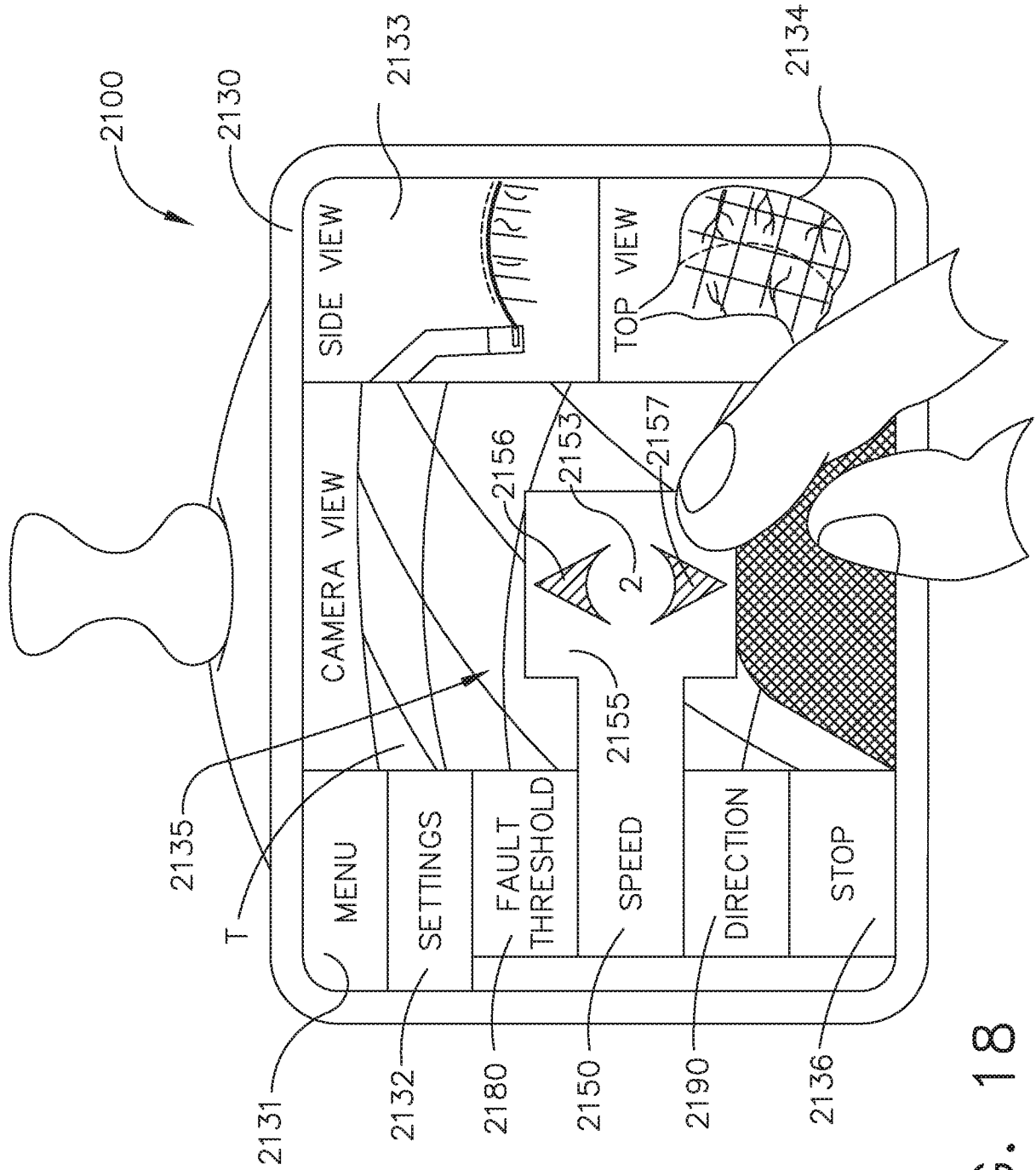

FIG. 18

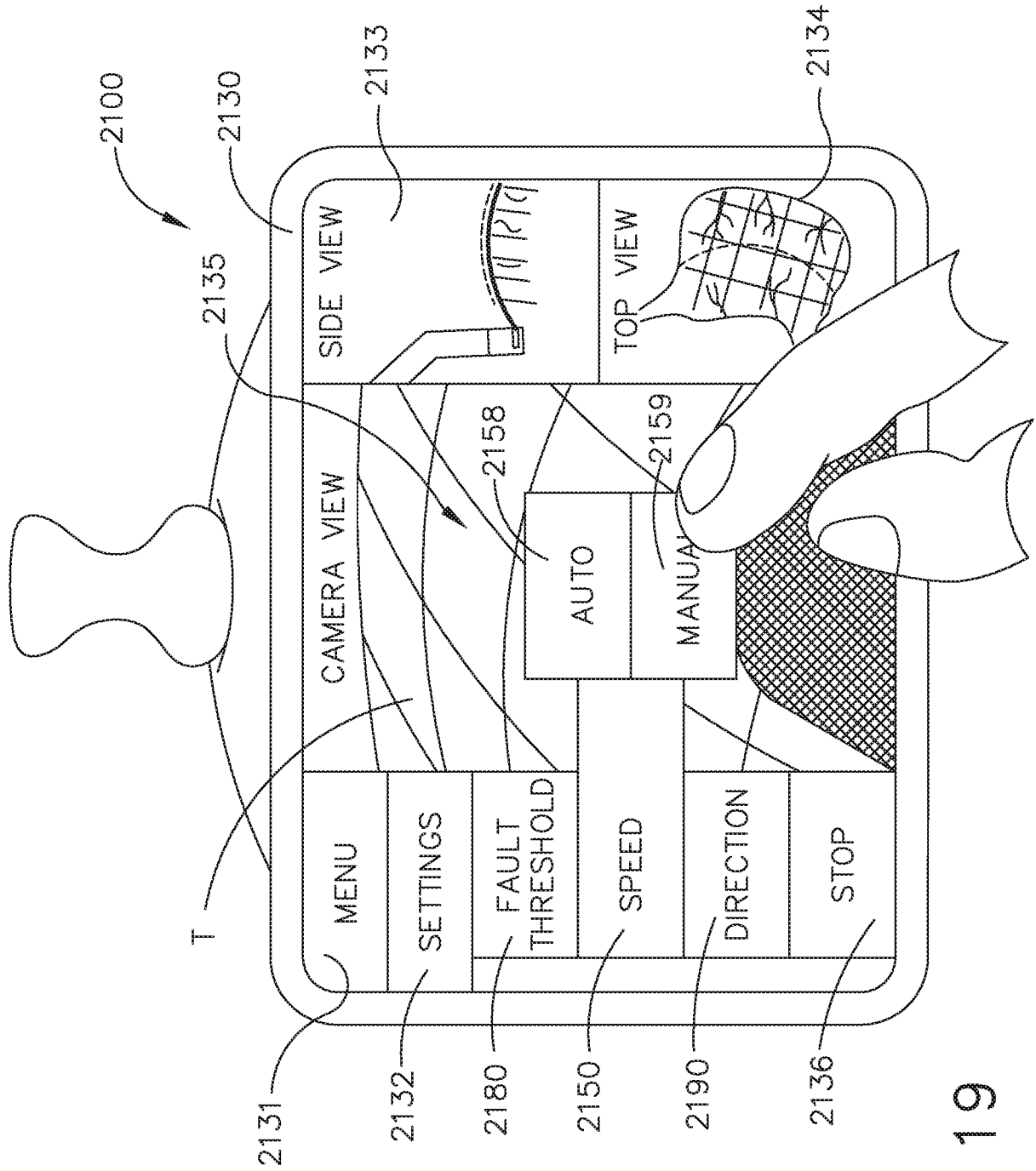

FIG. 19

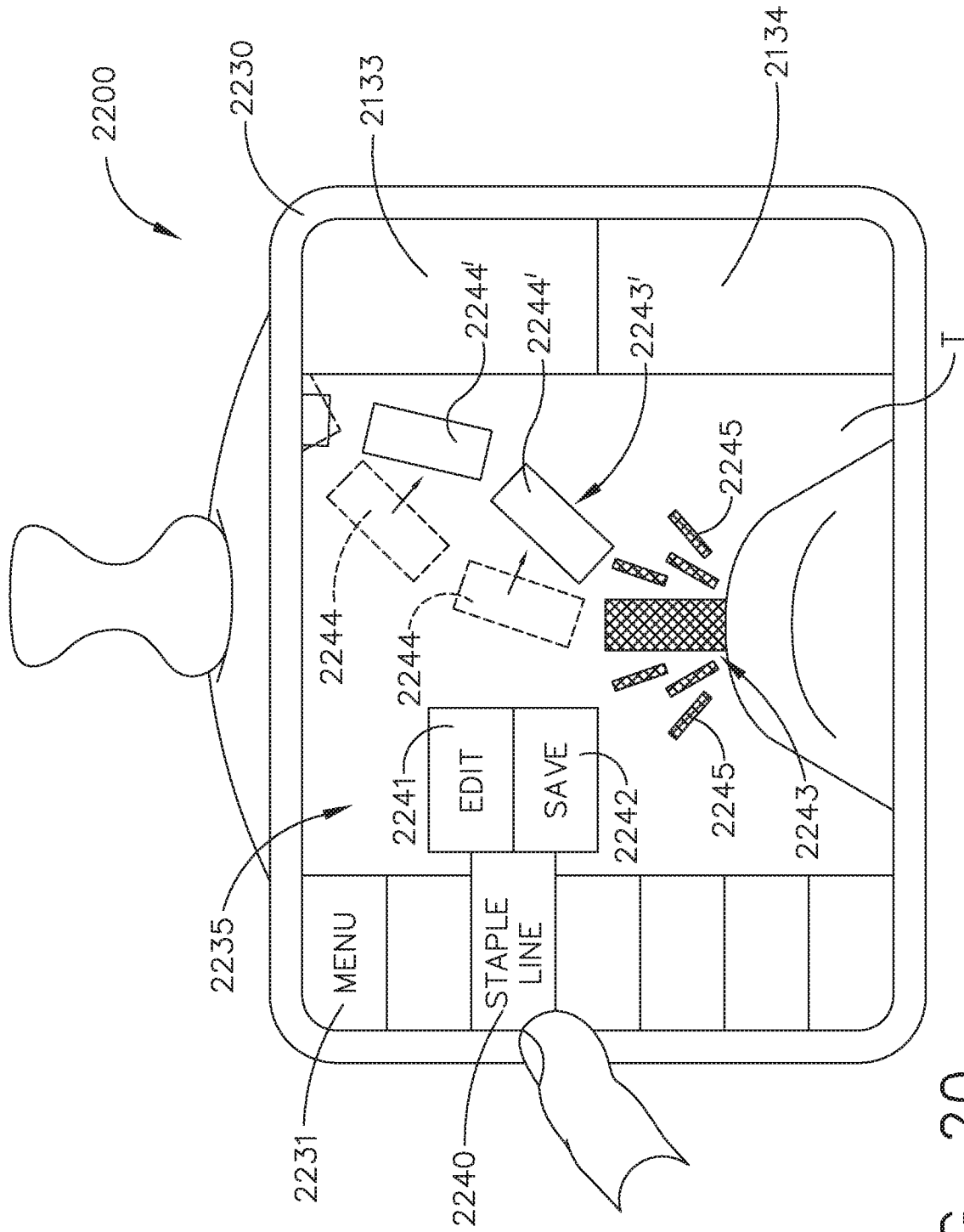

FIG. 20

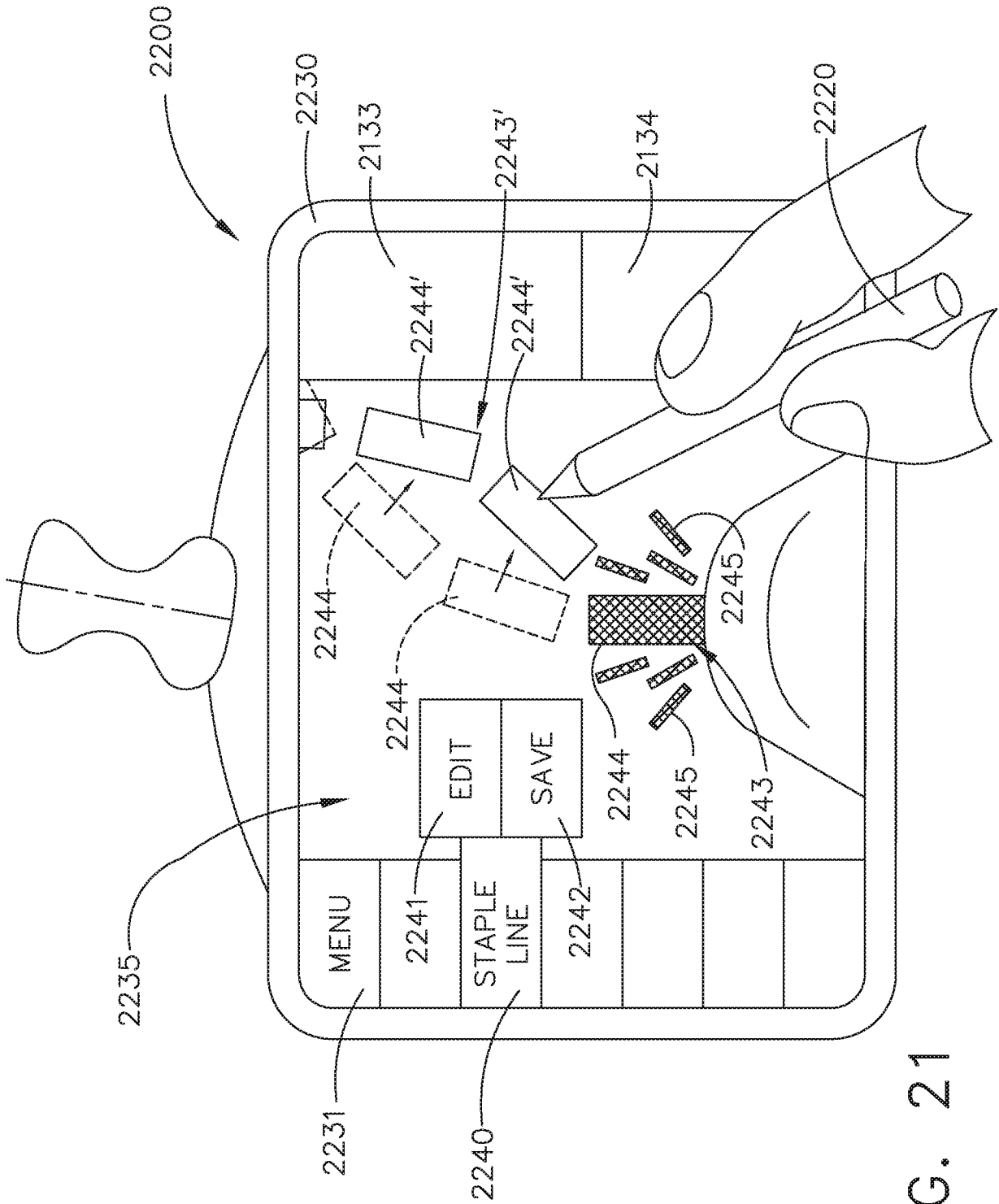

FIG. 21

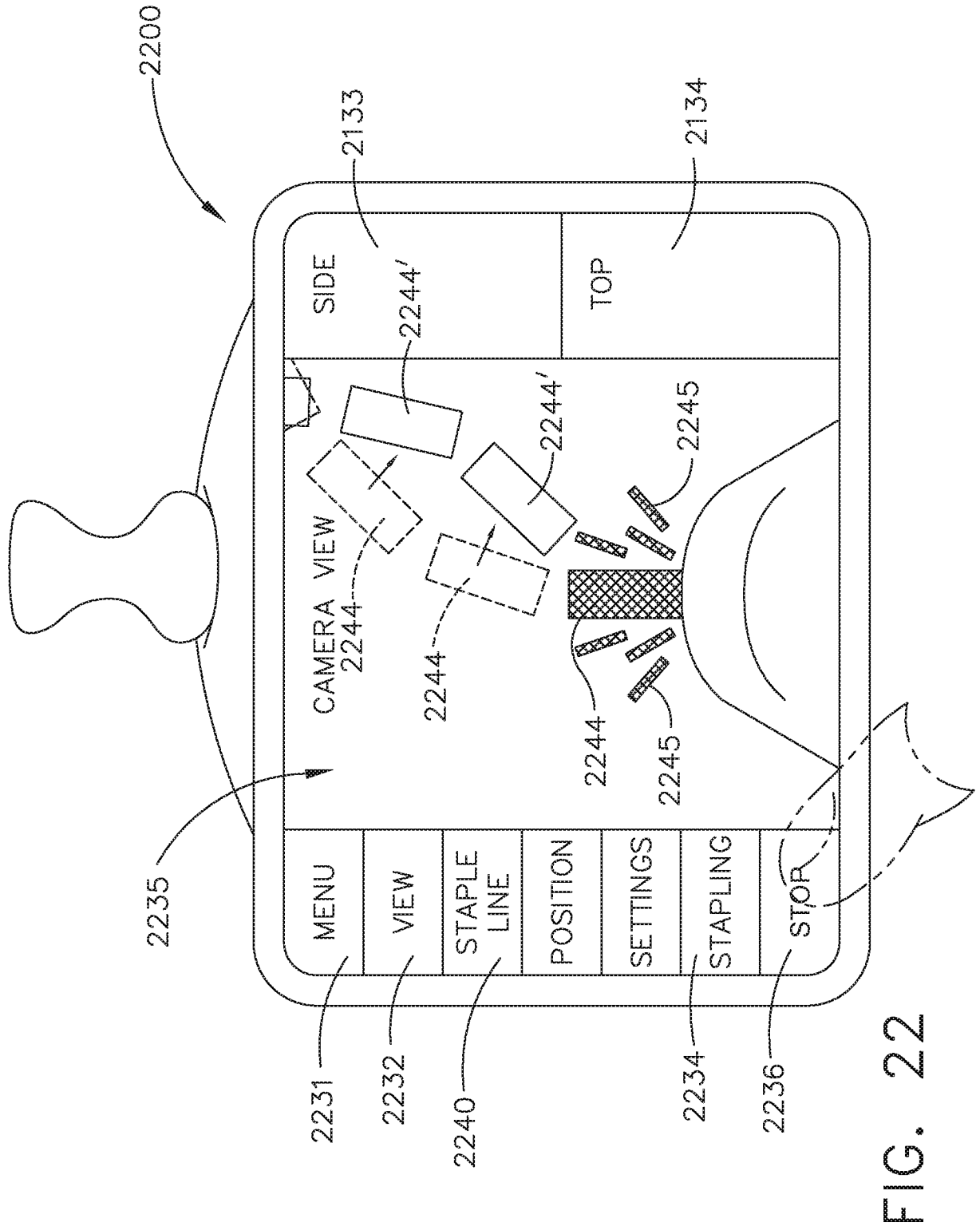

FIG. 22

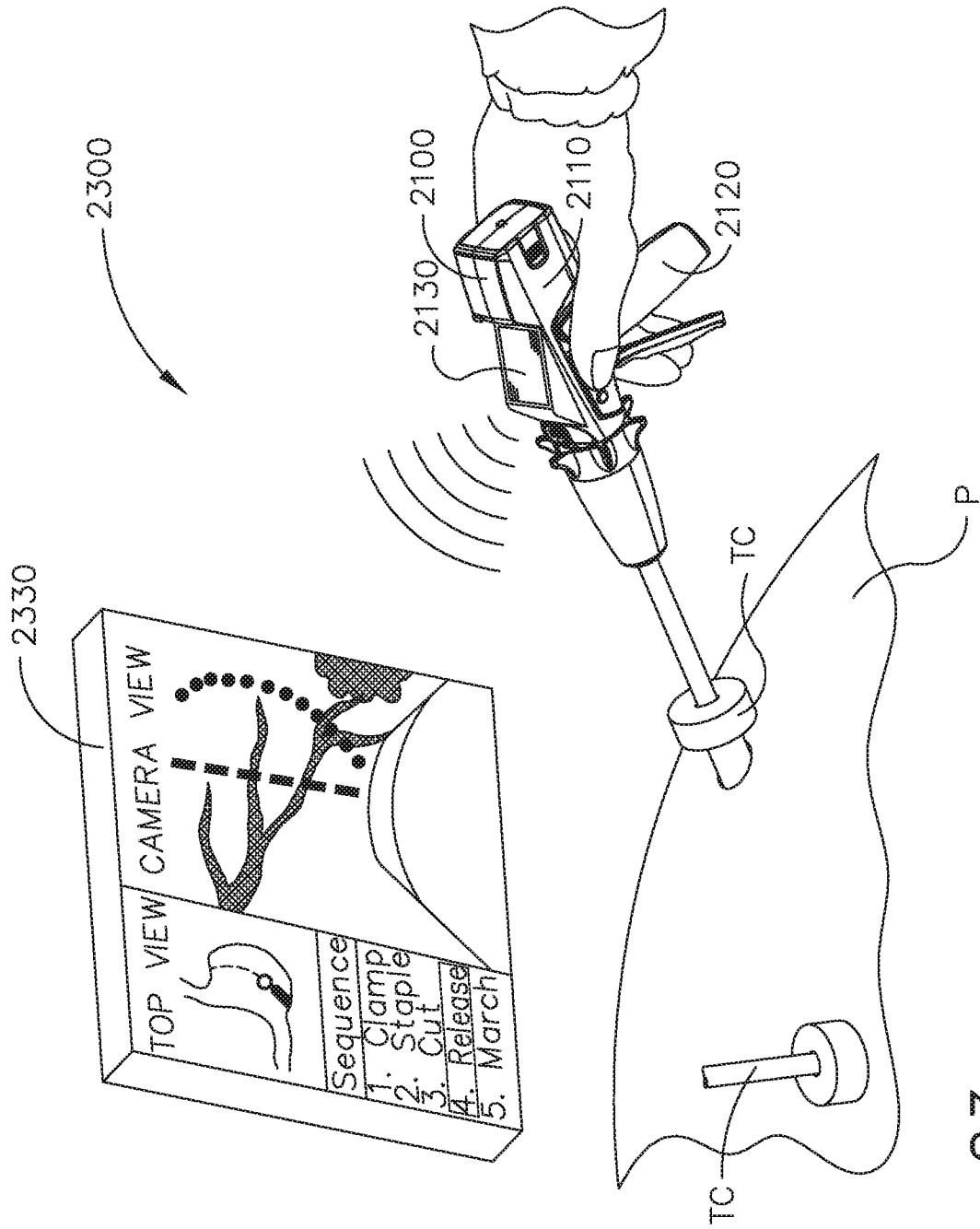

FIG. 23

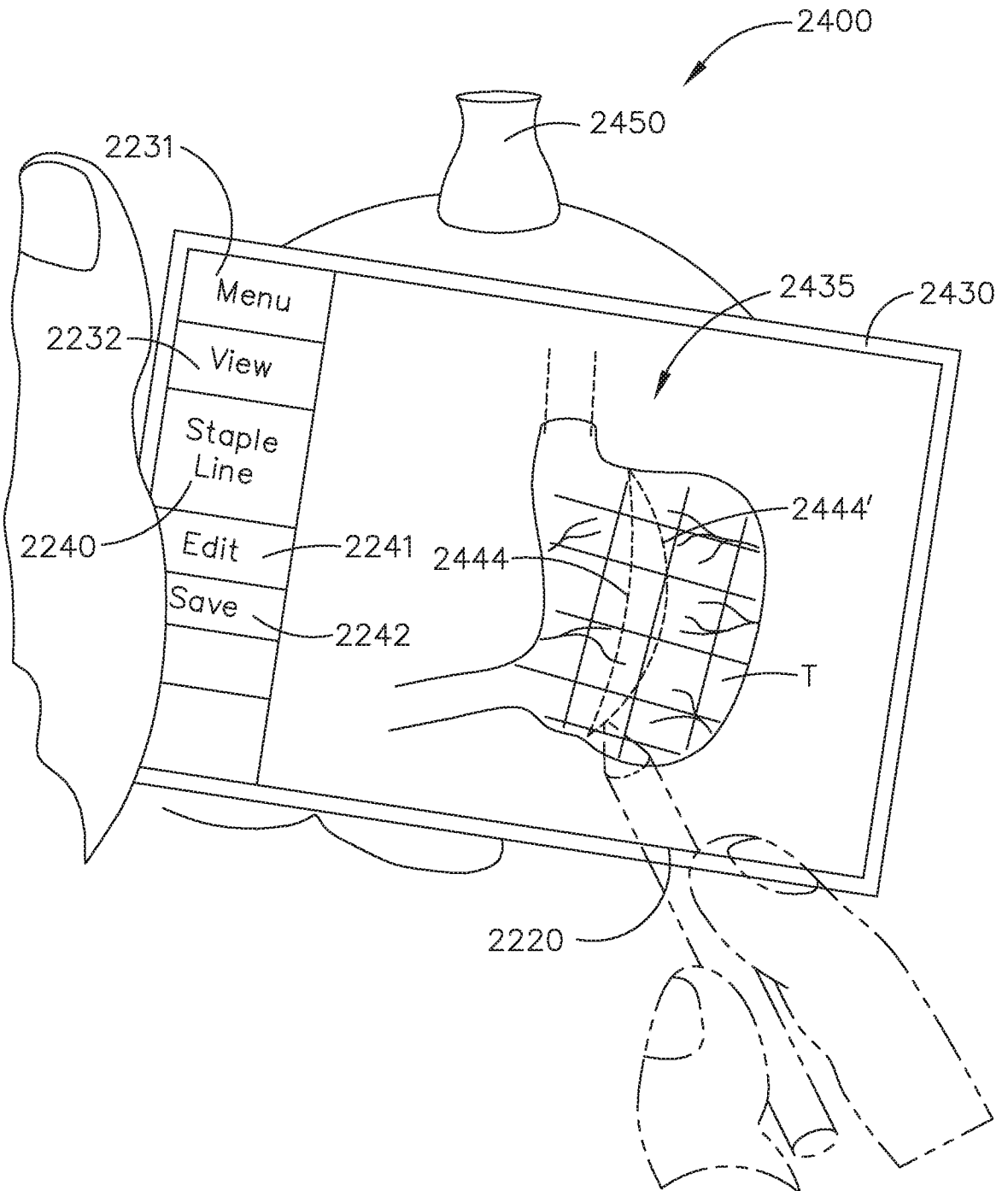

FIG. 24

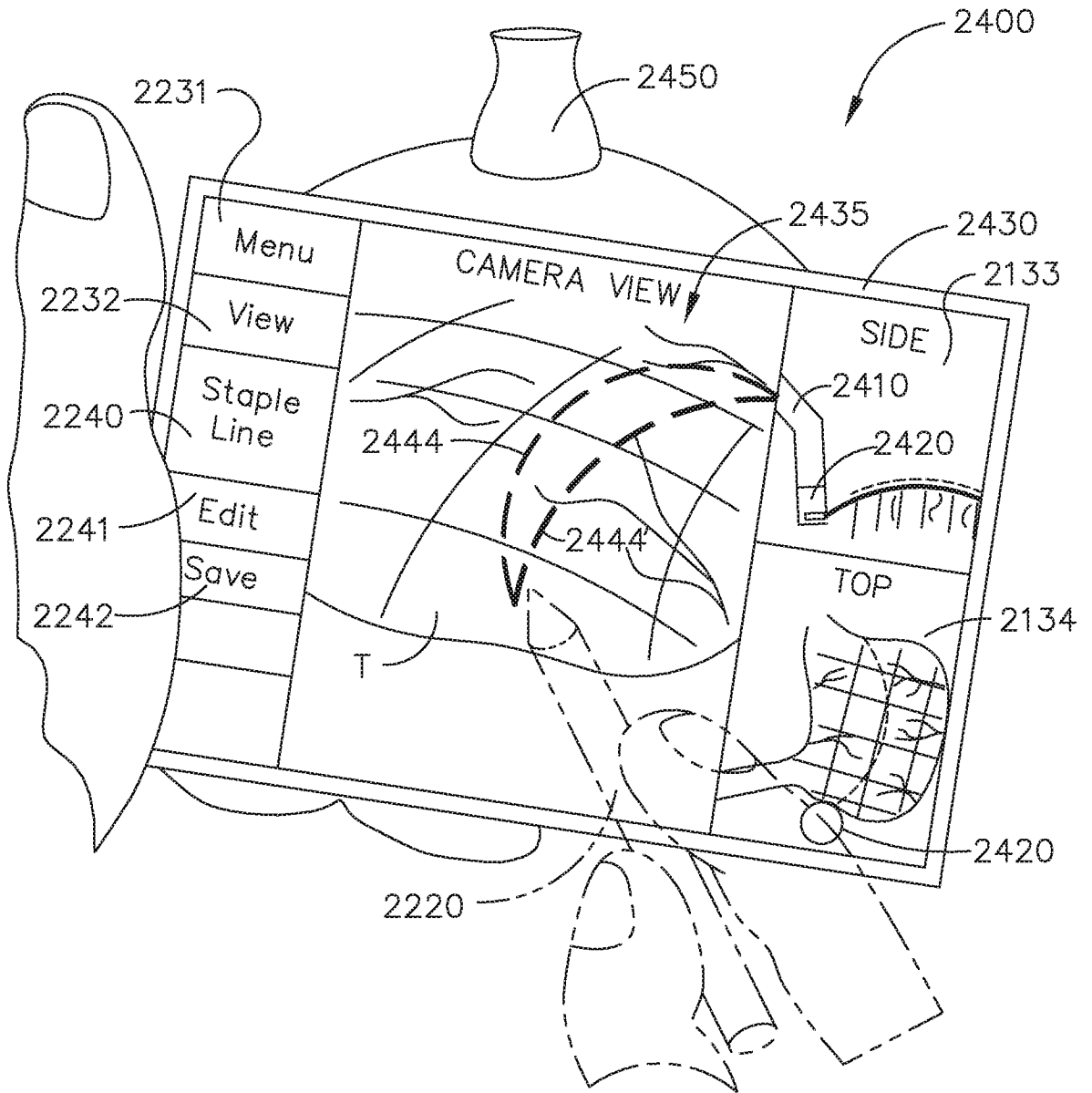

FIG. 25

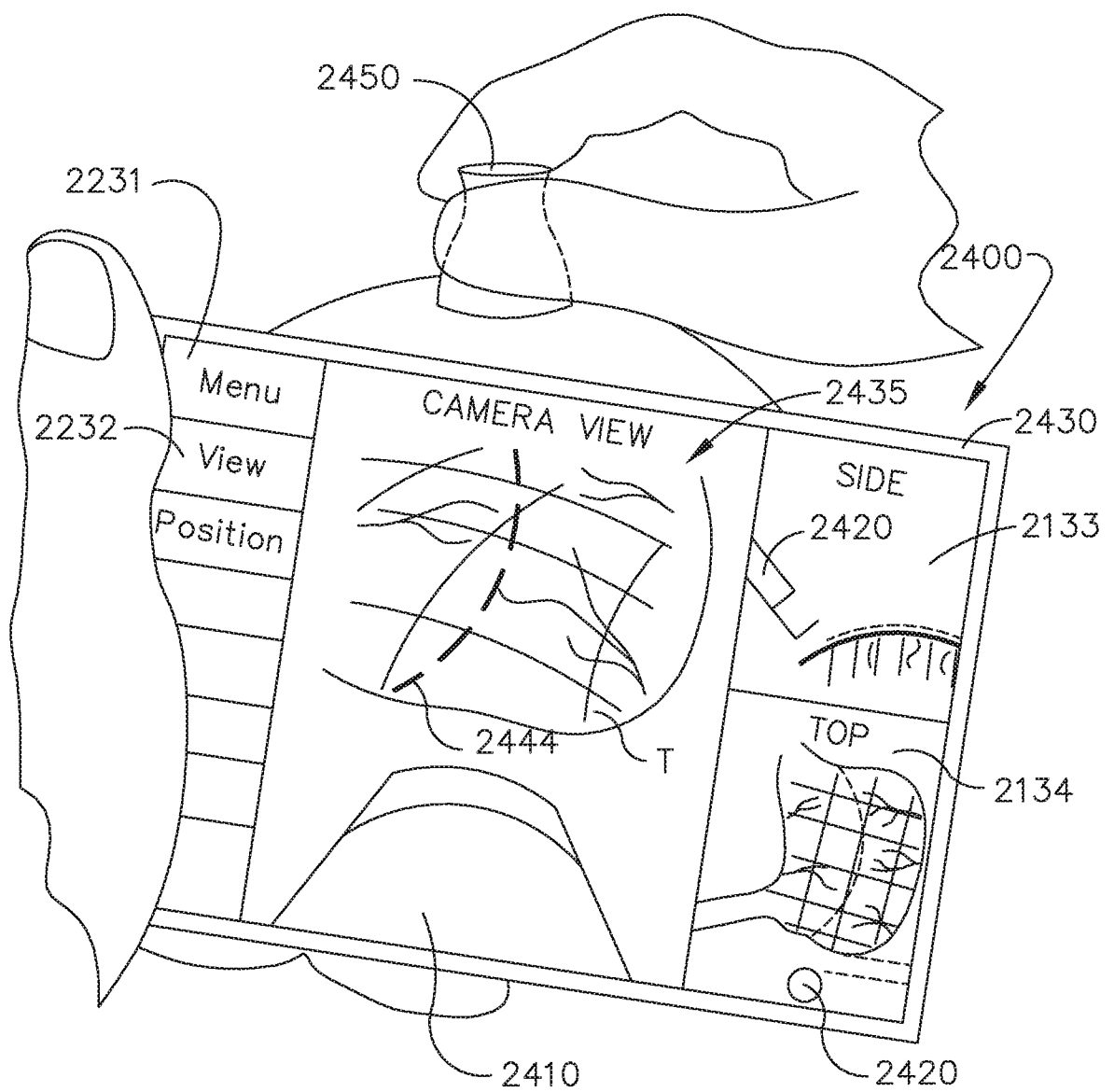

FIG. 26

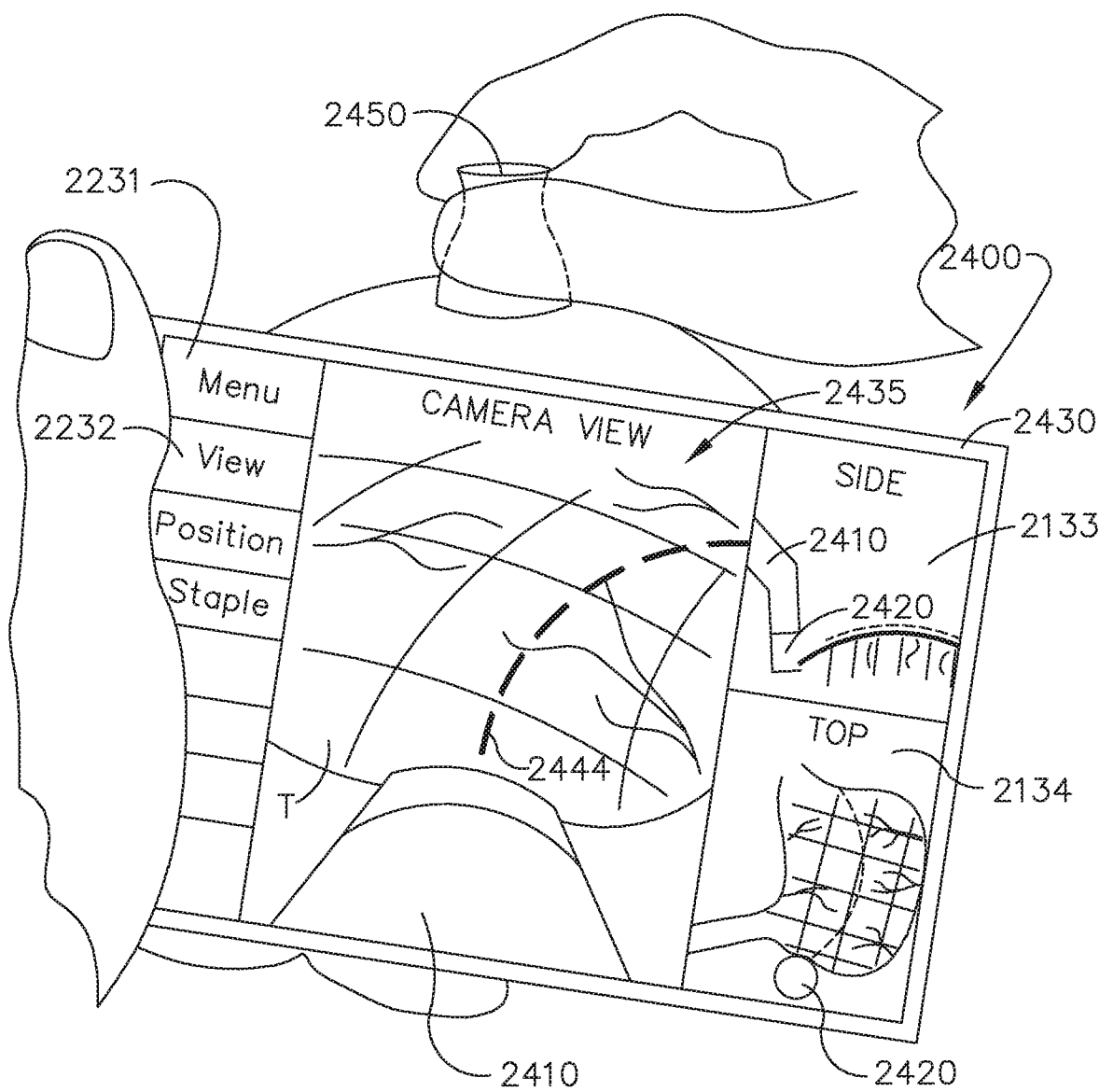

FIG. 27

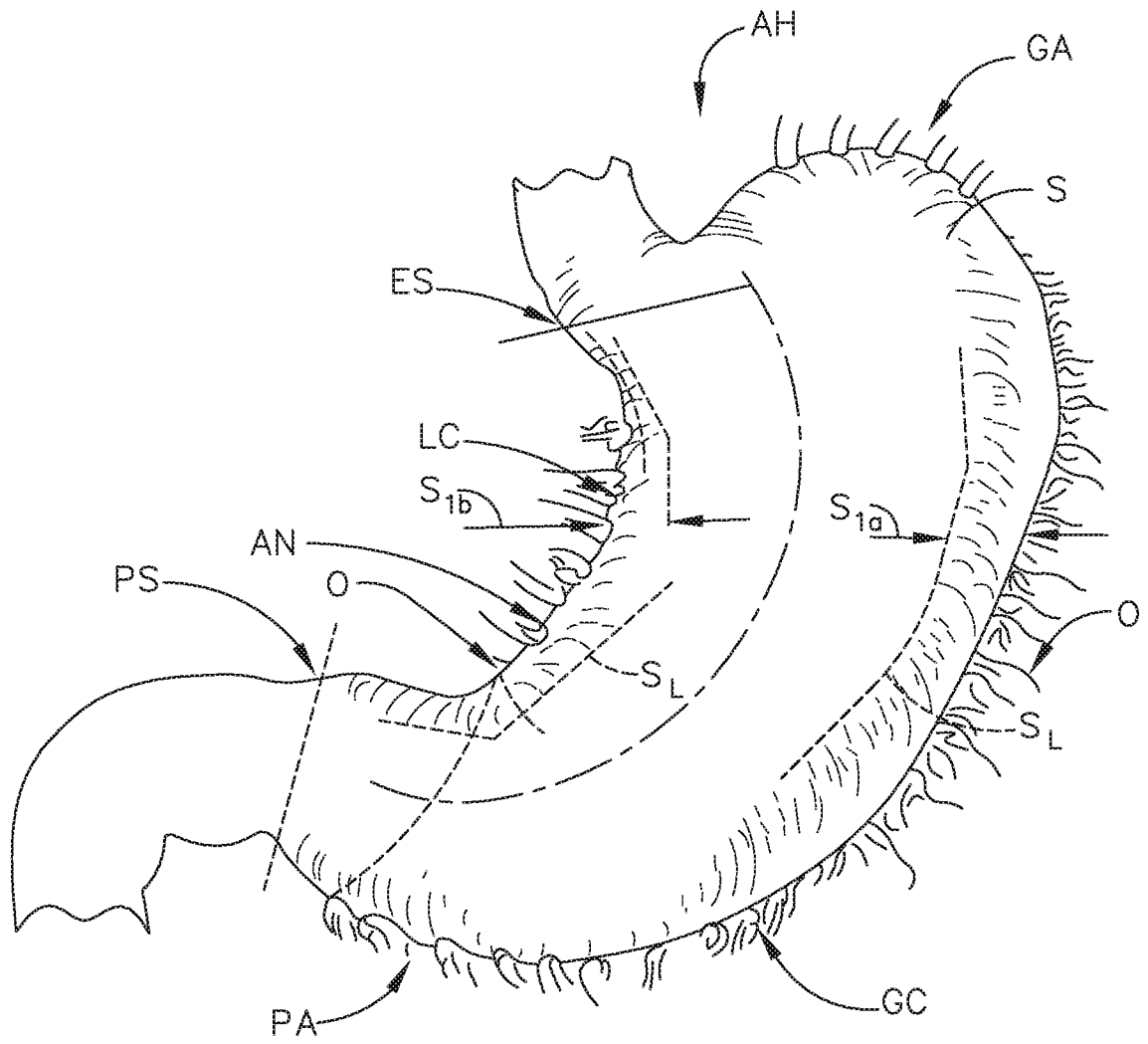

FIG. 28

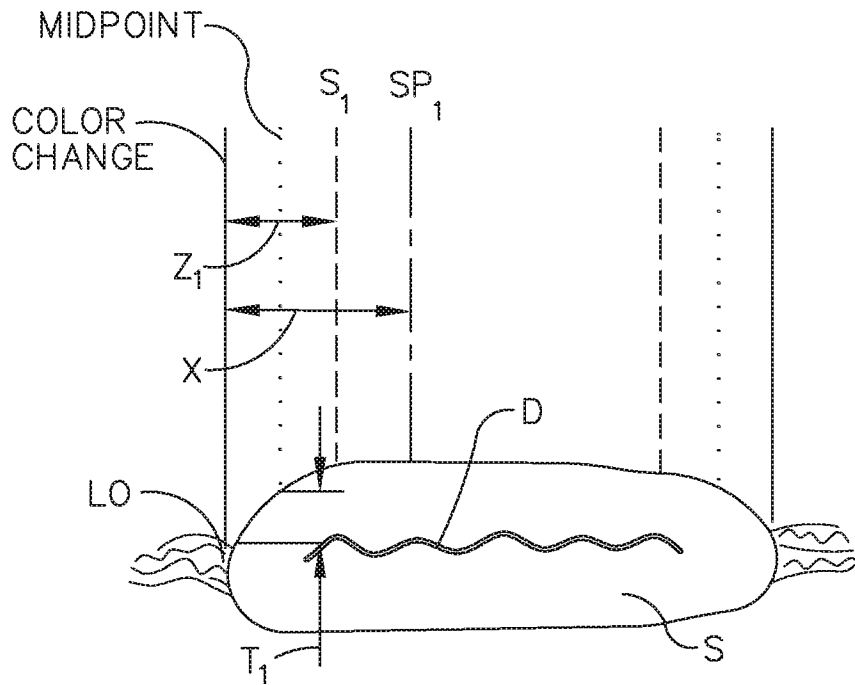

FIG. 29

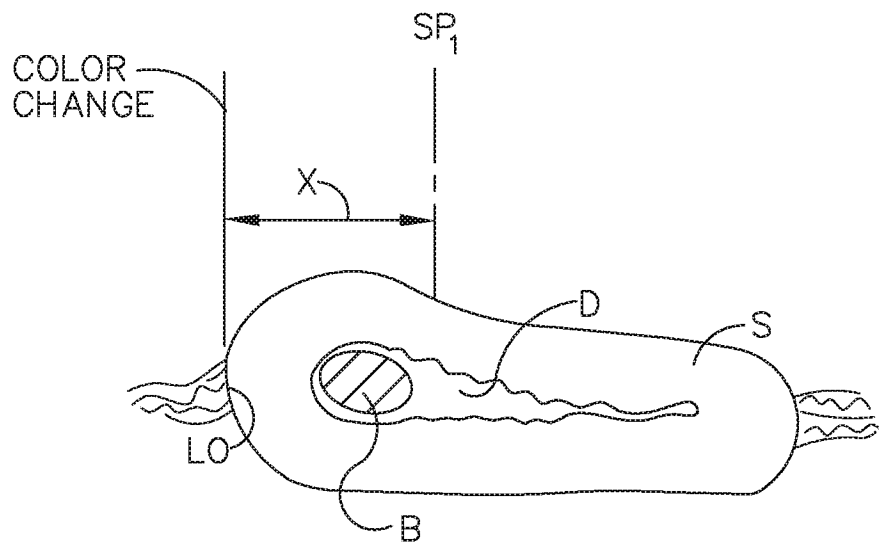

FIG. 30

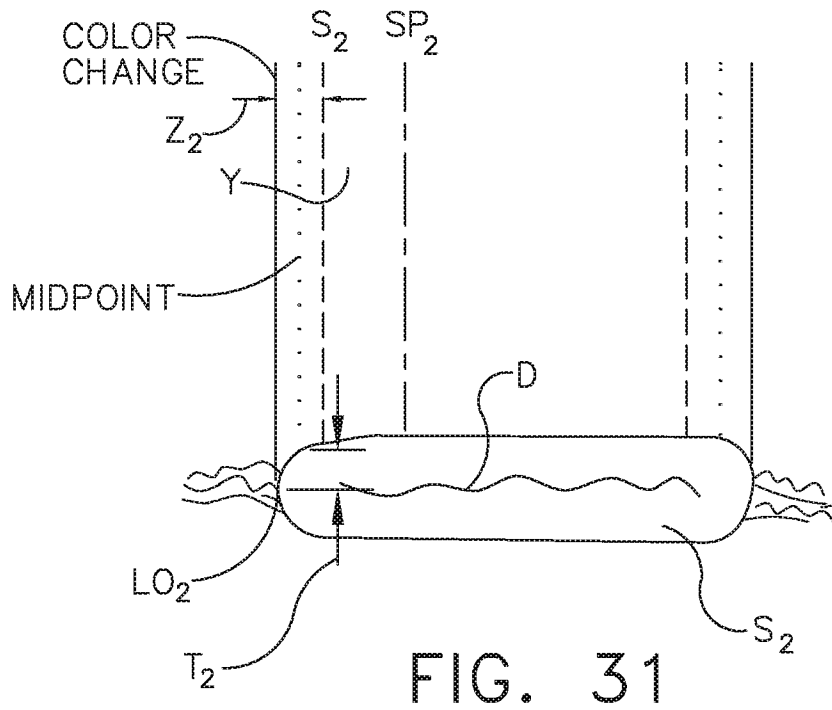

FIG. 31

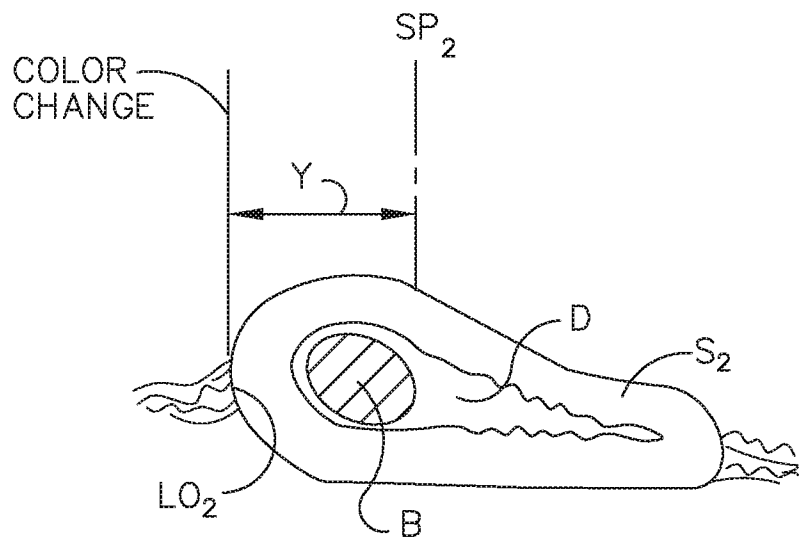

FIG. 32

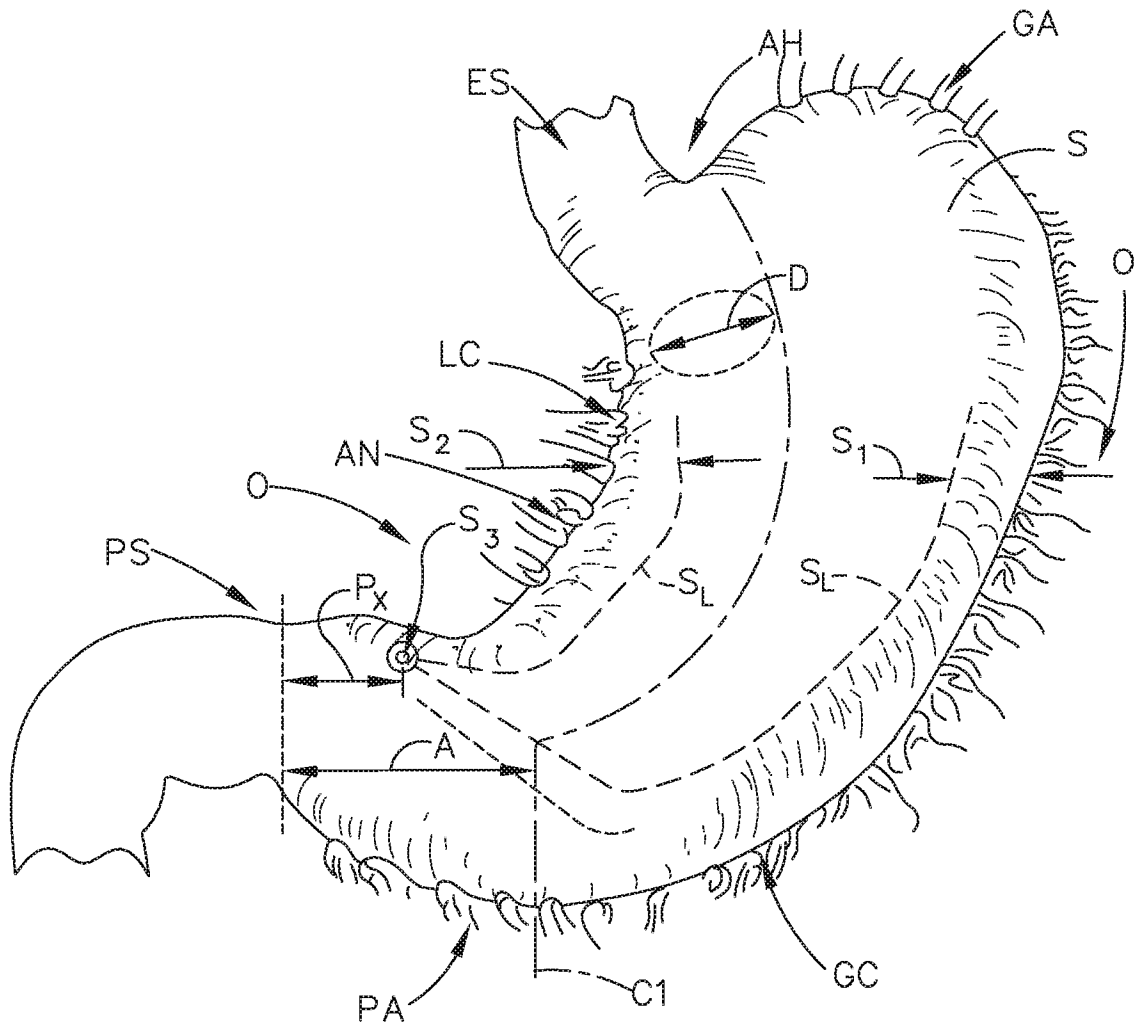

FIG. 33

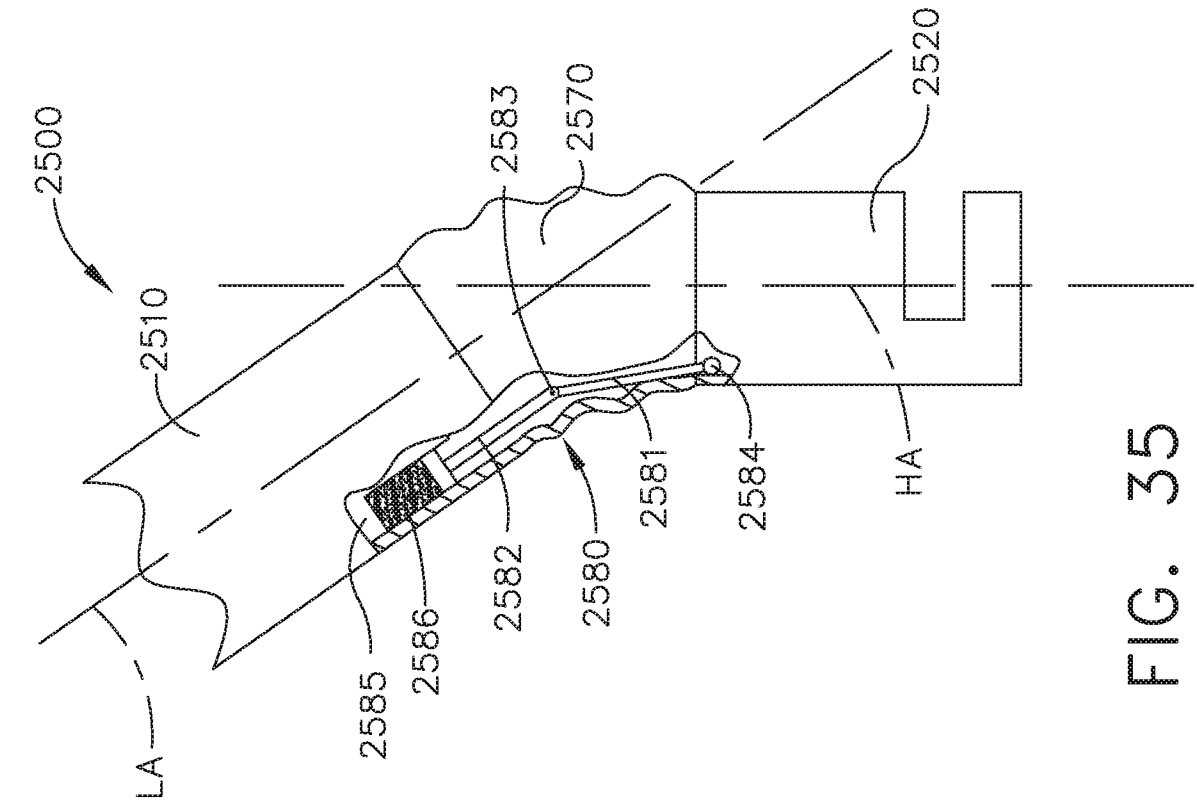

FIG. 34

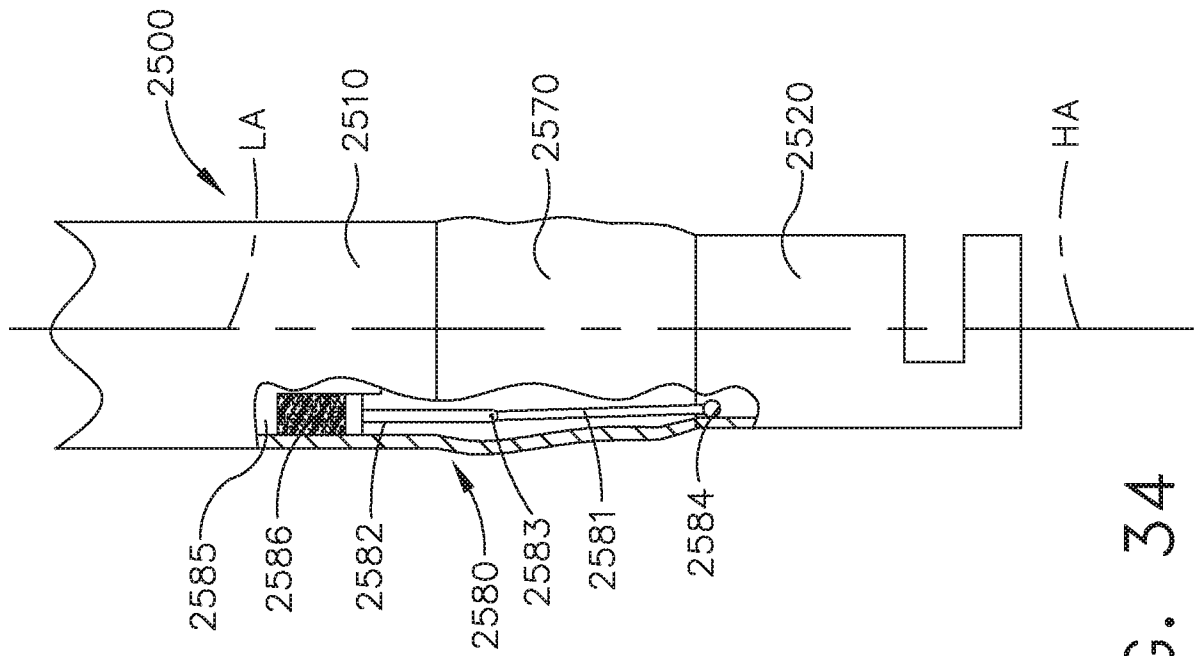

FIG. 35

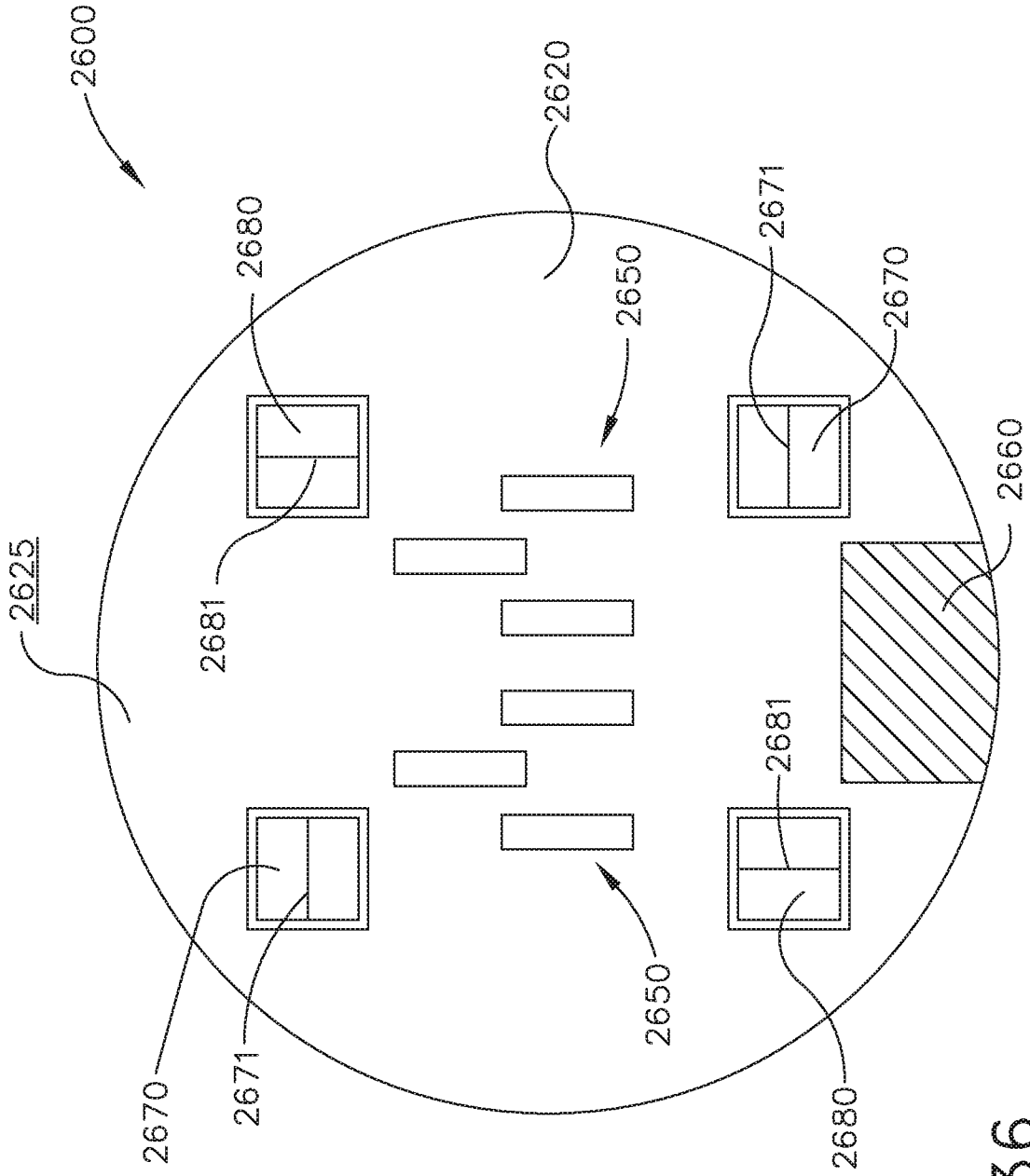

FIG. 36

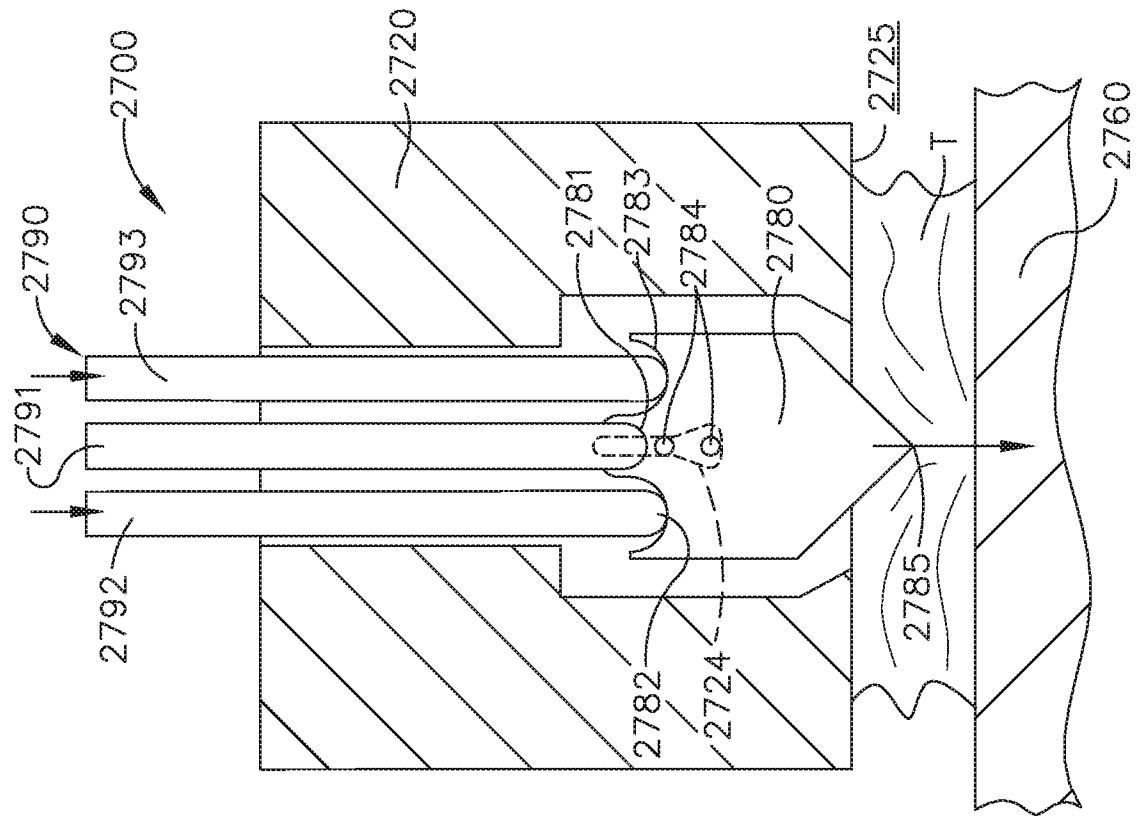

FIG. 38

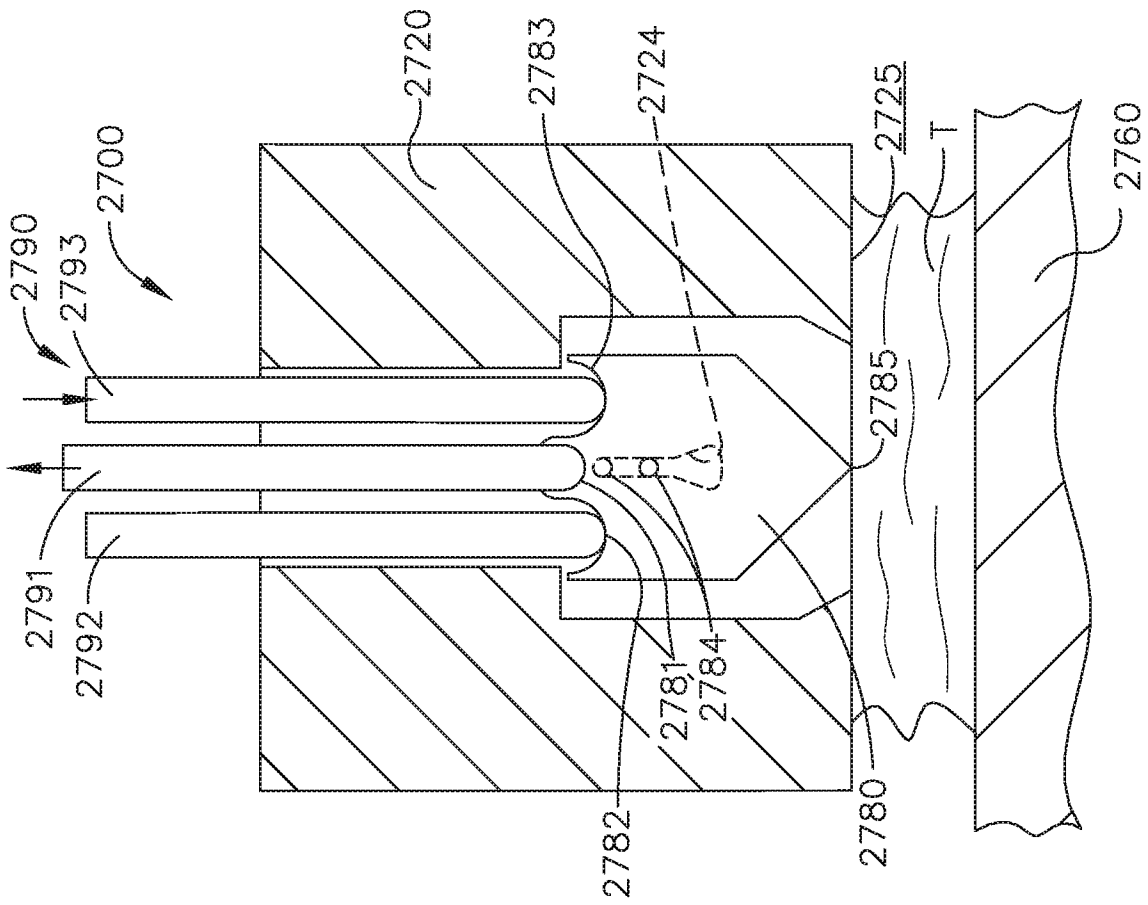

FIG. 37

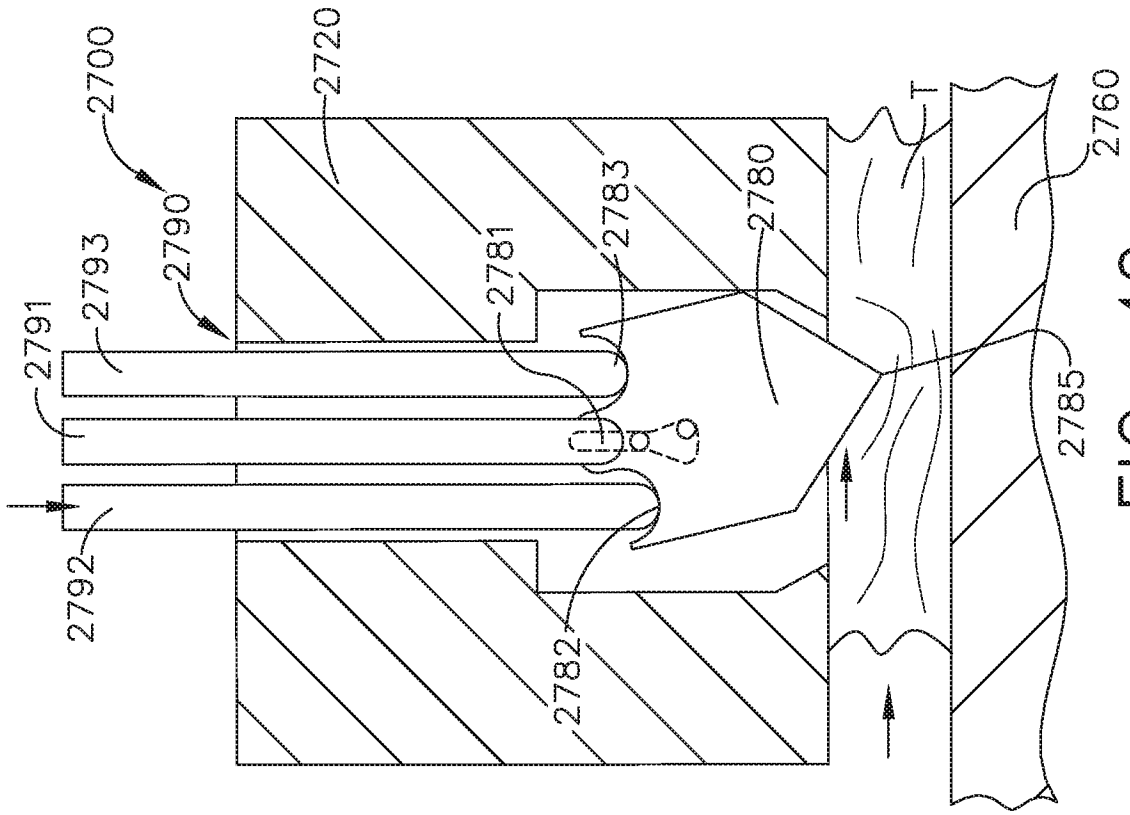

FIG. 40

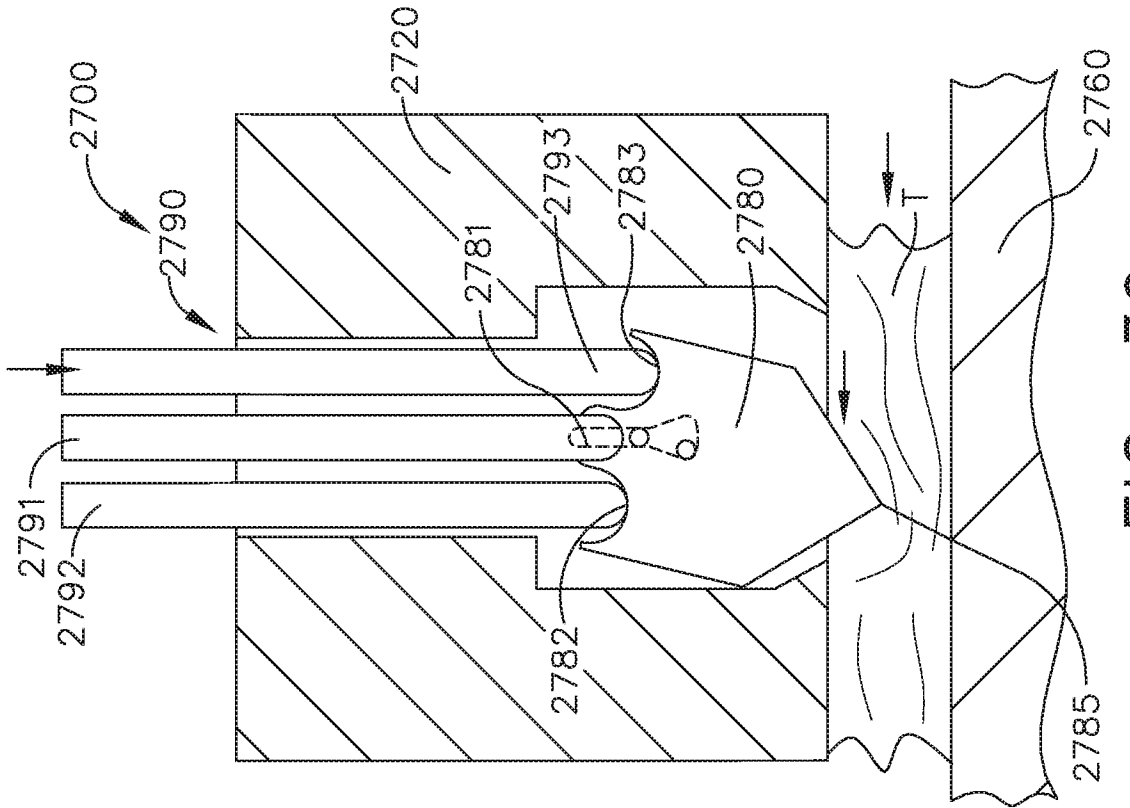

FIG. 39

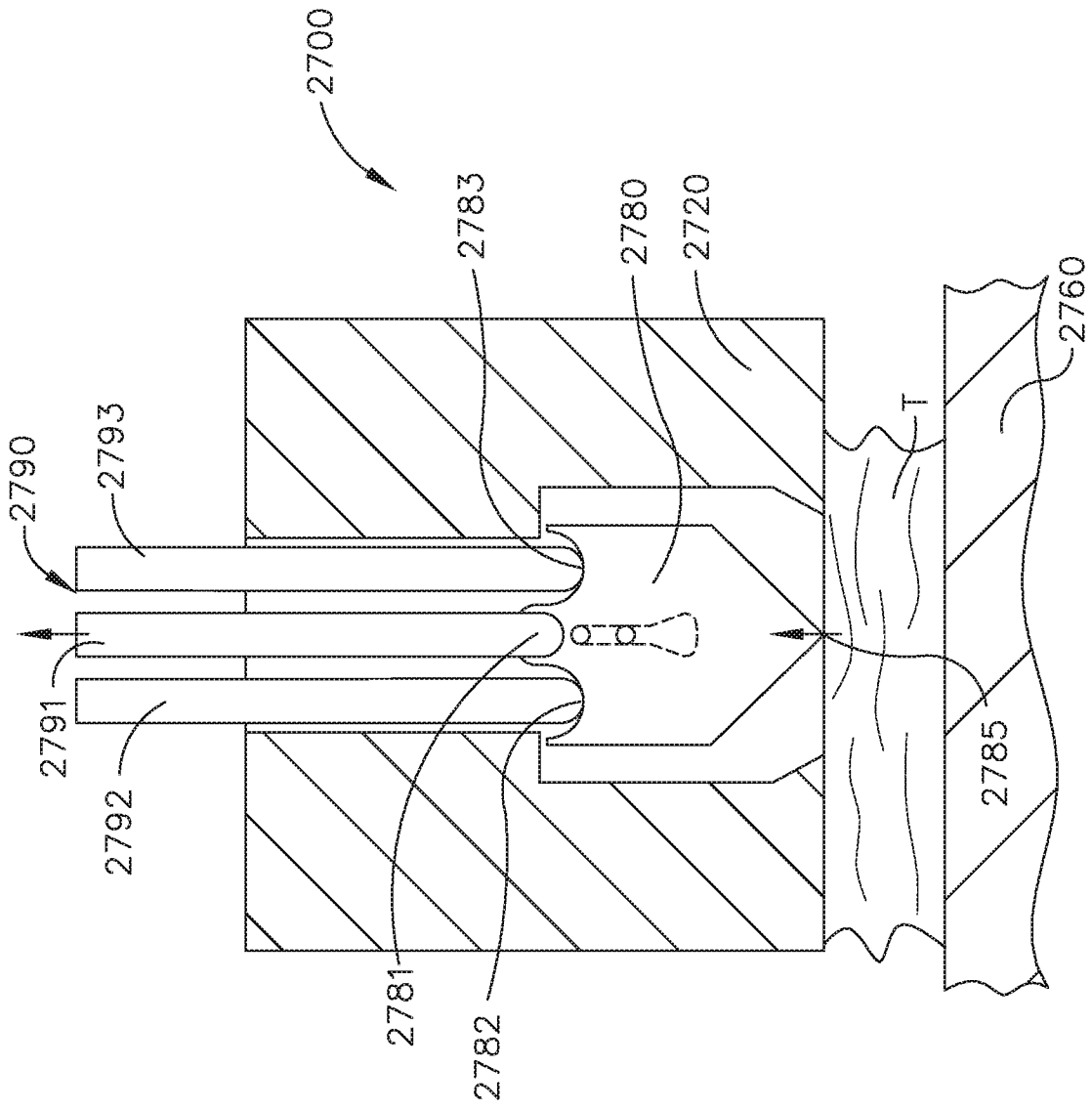

FIG. 41

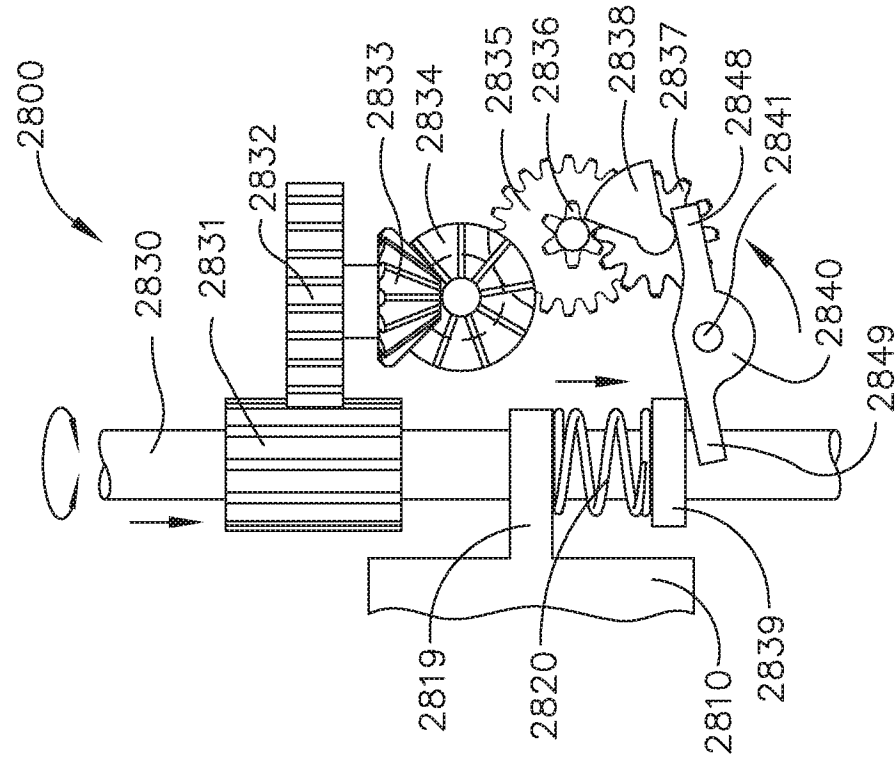

FIG. 42

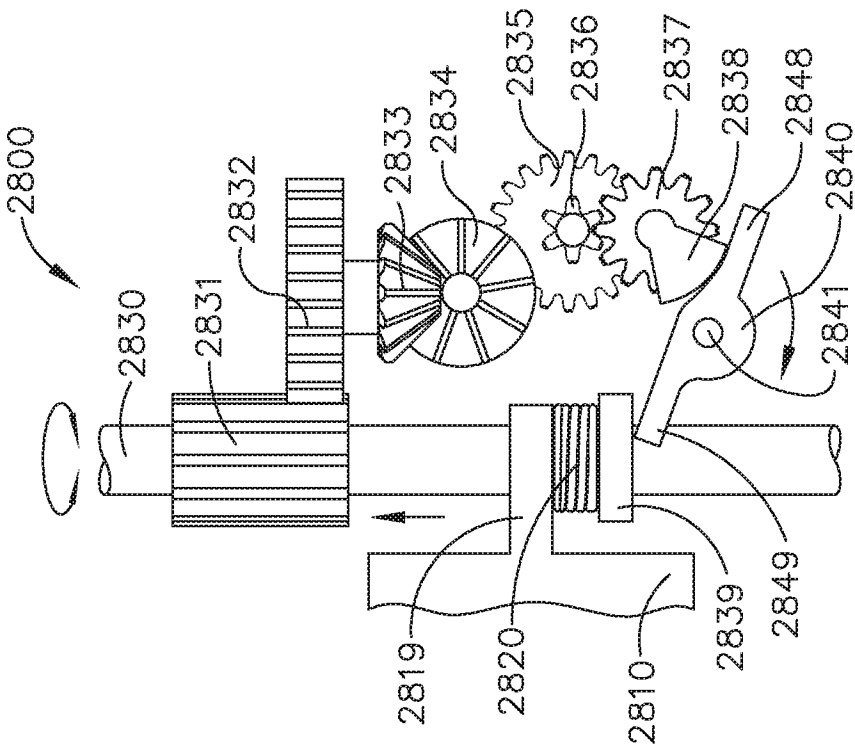

FIG. 43

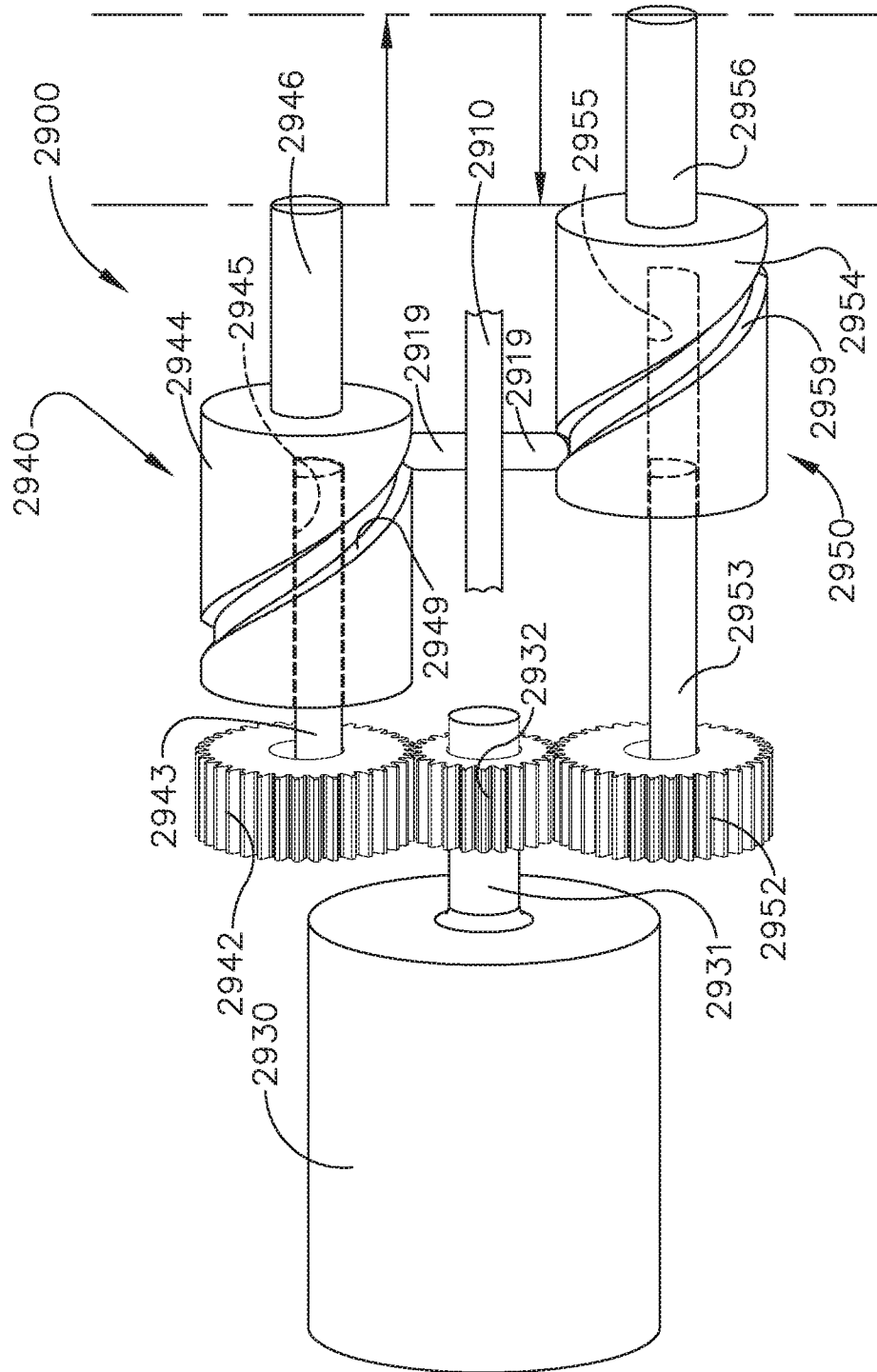

FIG. 44

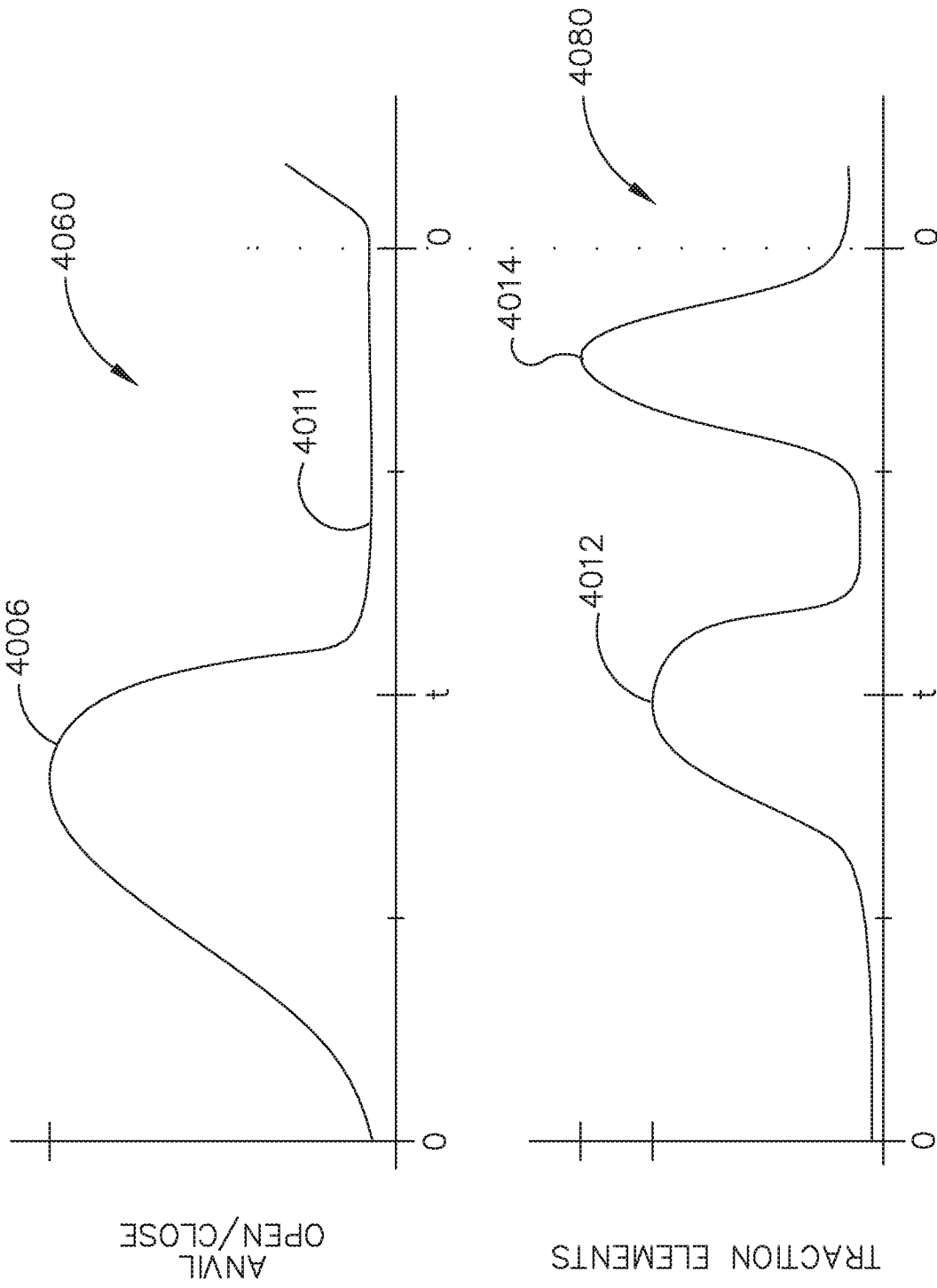

FIG. 45

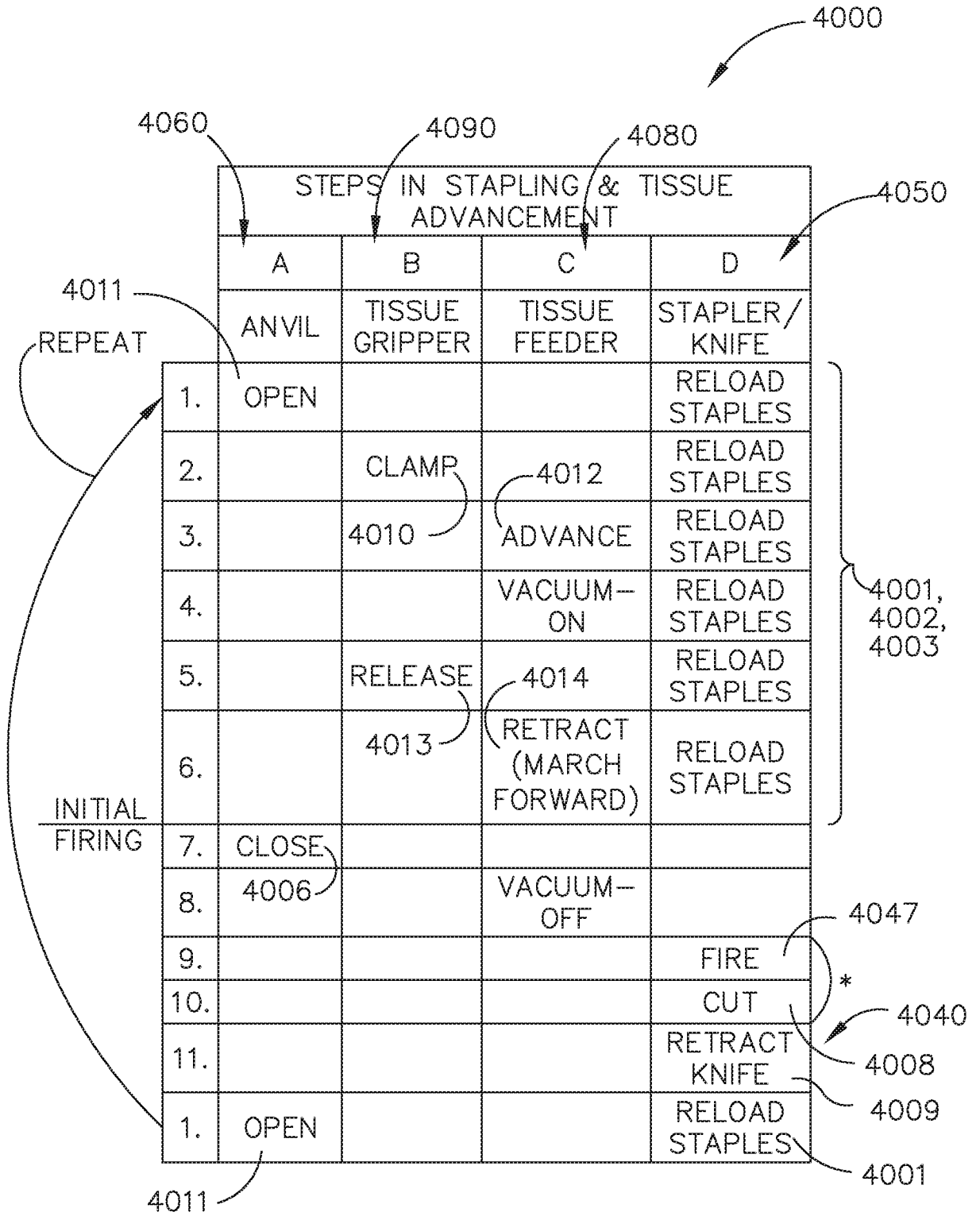

FIG. 46

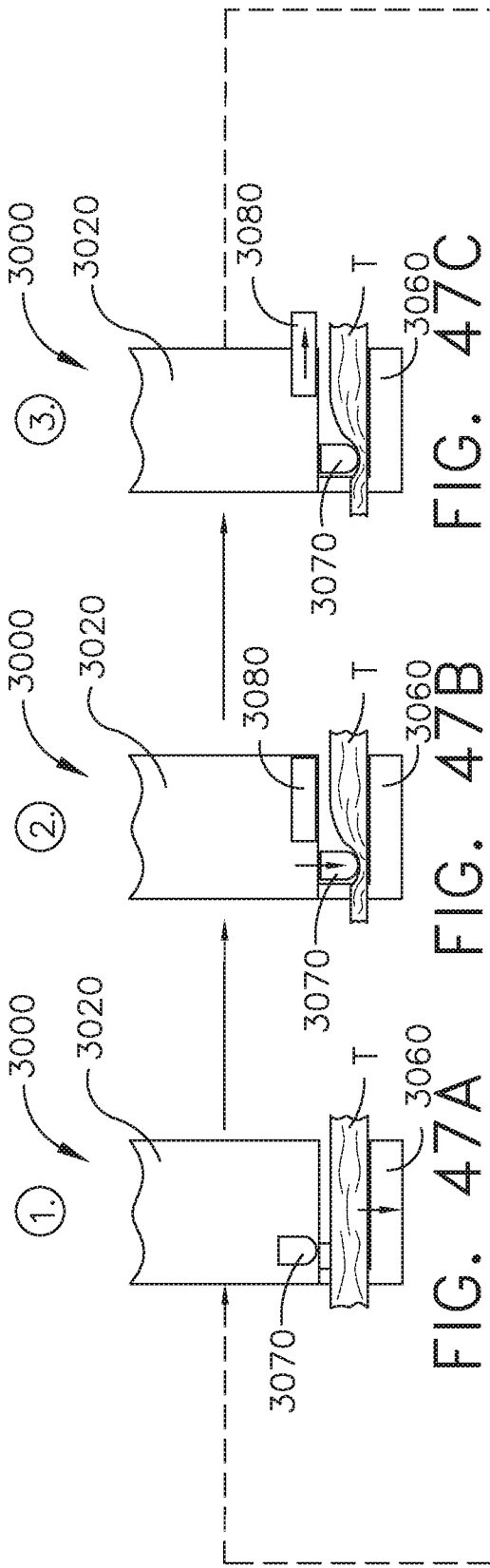

FIG. 47A FIG. 47B FIG. 47C

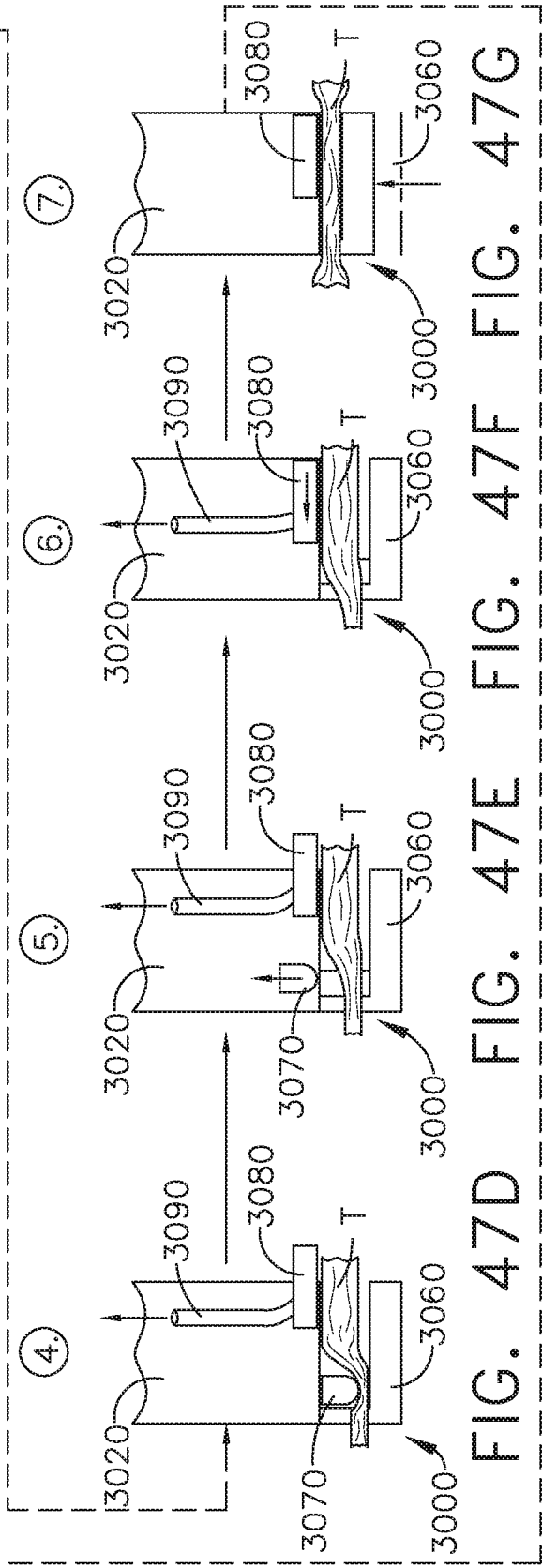

FIG. 47D FIG. 47E FIG. 47F FIG. 47G

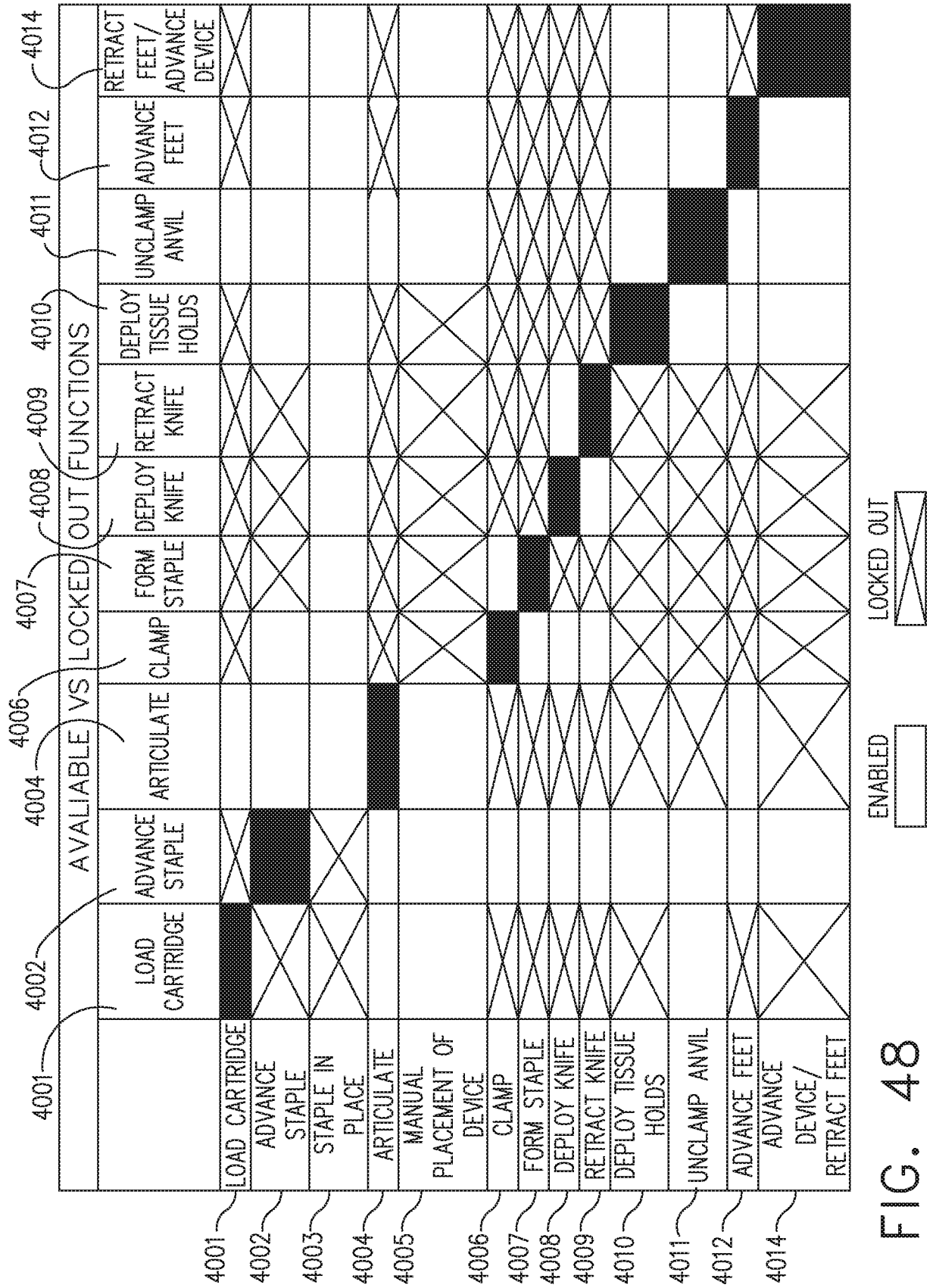

FIG. 48

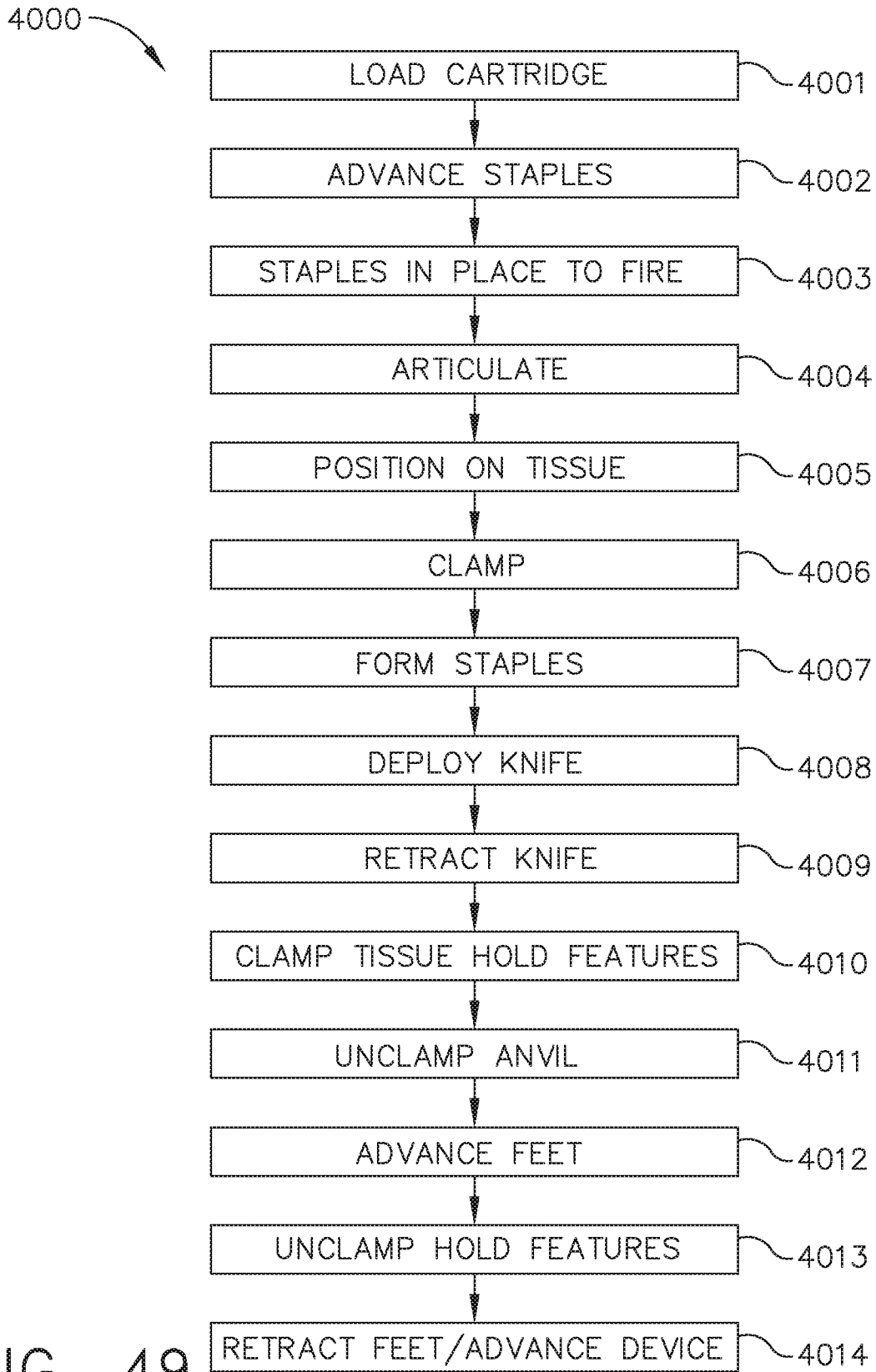

FIG. 49

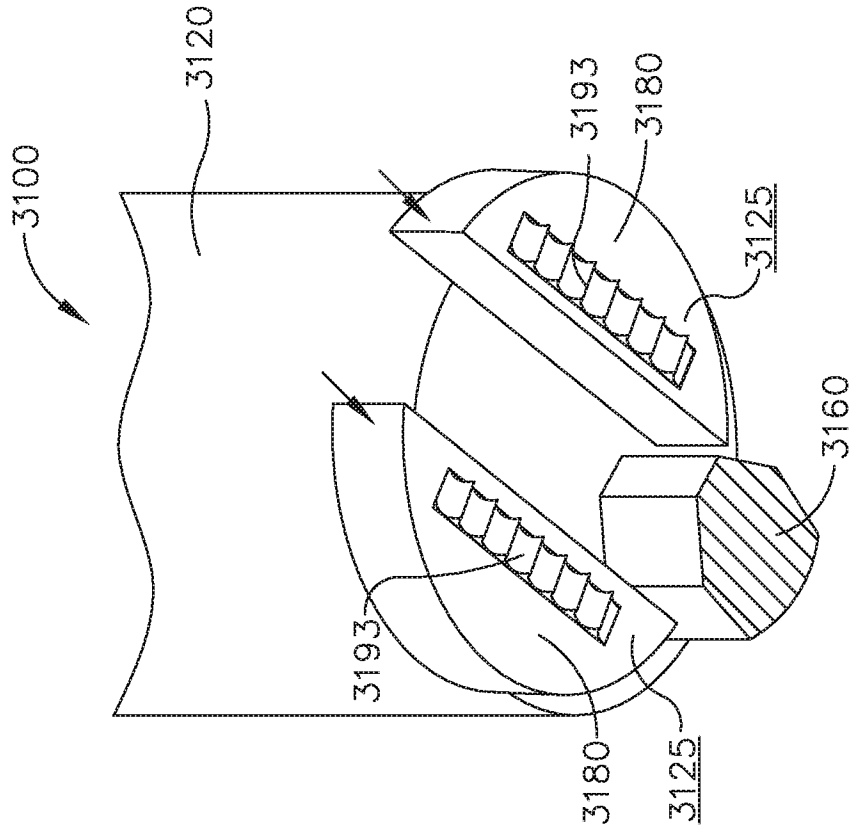

FIG. 50

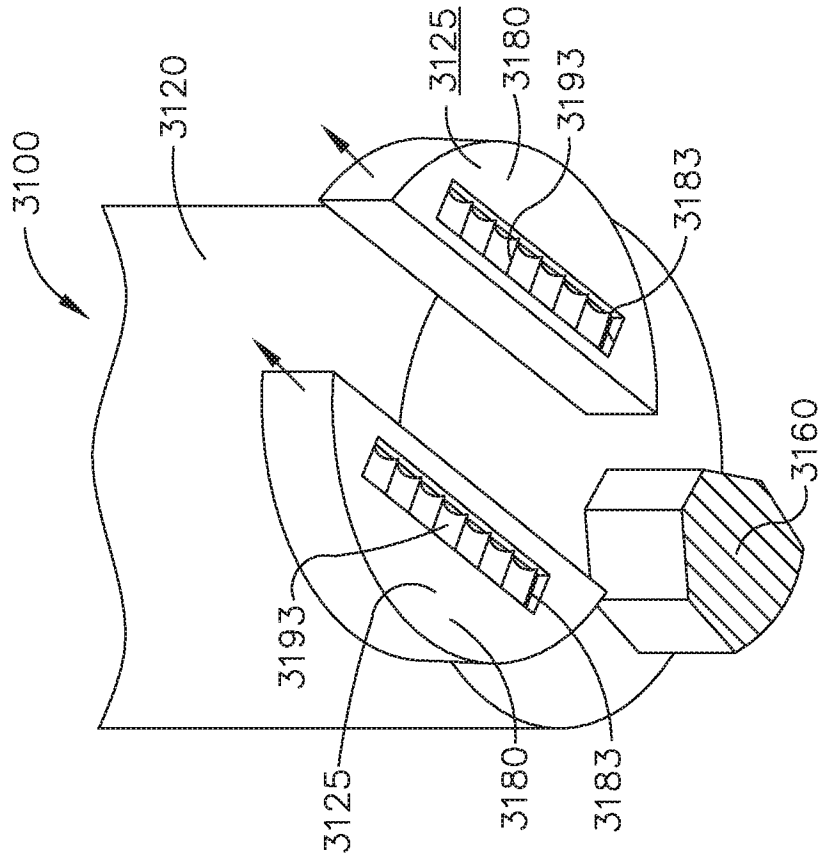

FIG. 51

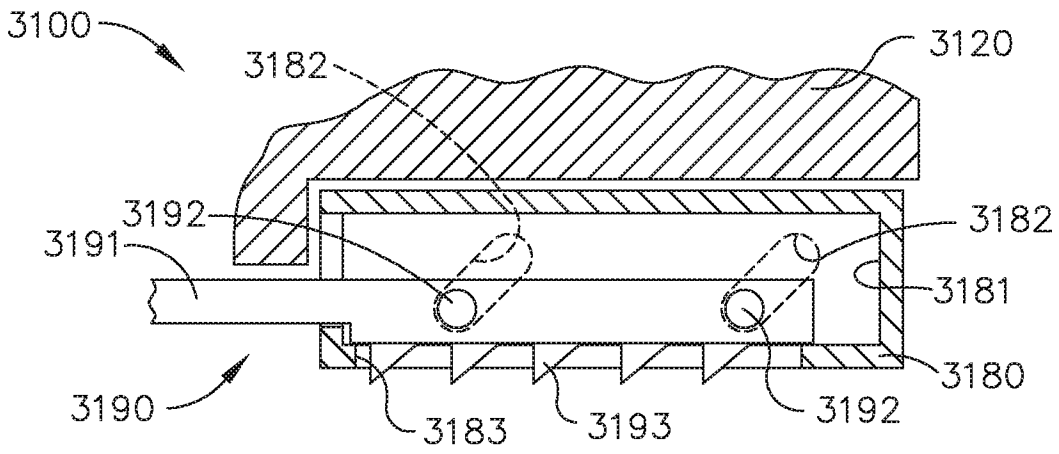

FIG. 52

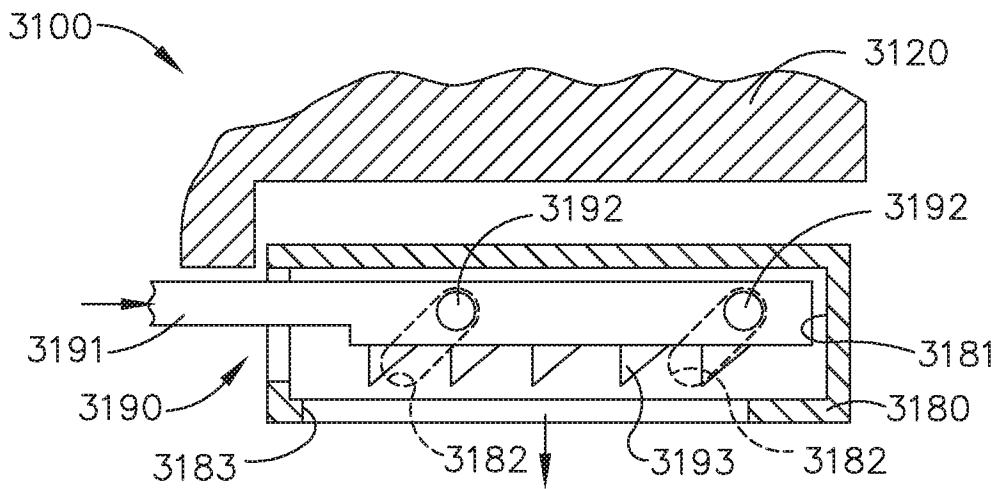

FIG. 53

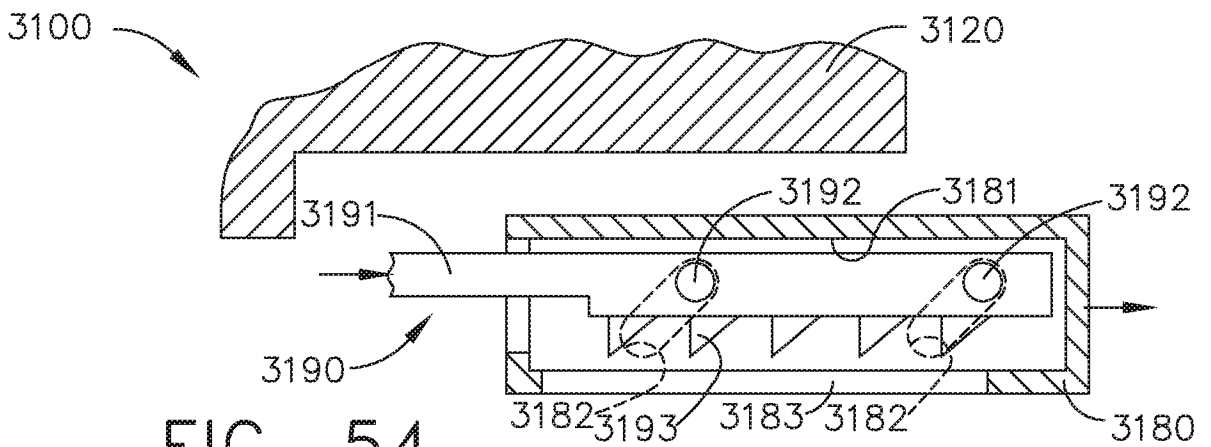

FIG. 54

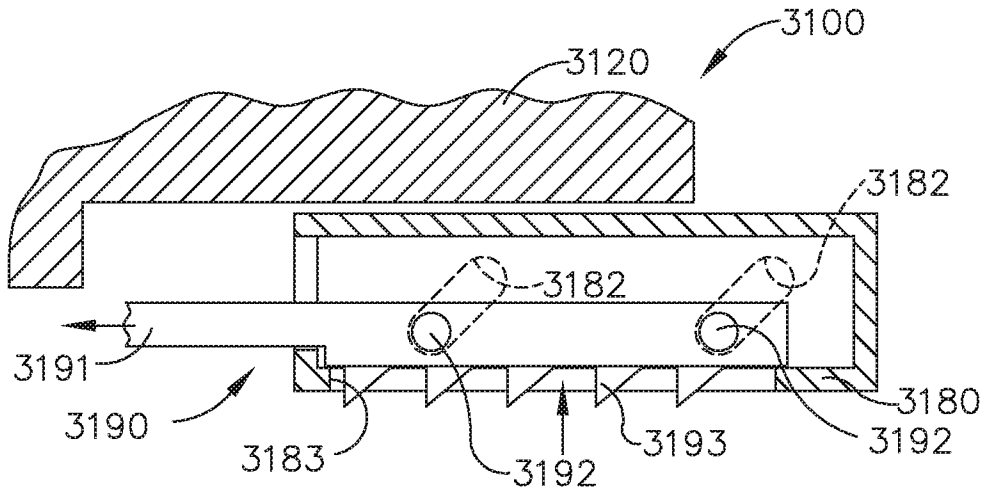

FIG. 55

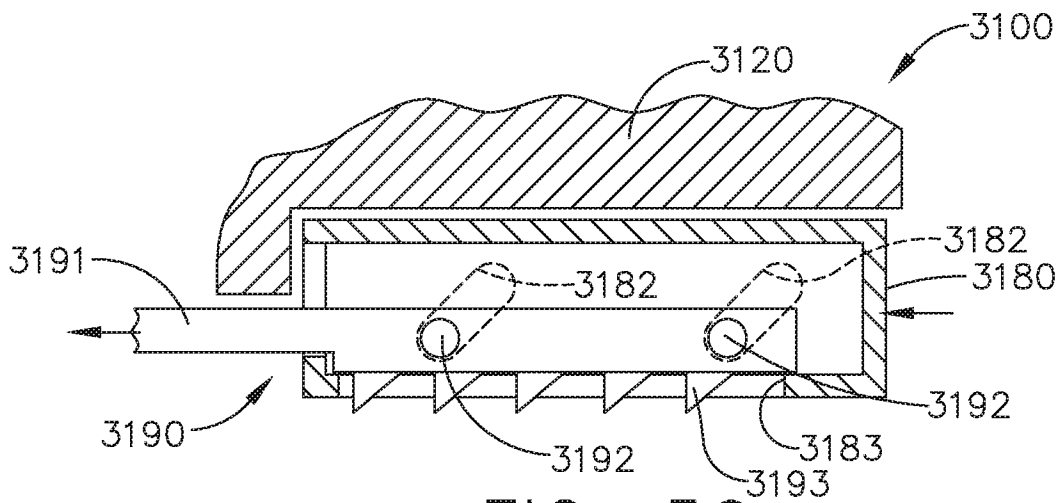

FIG. 56

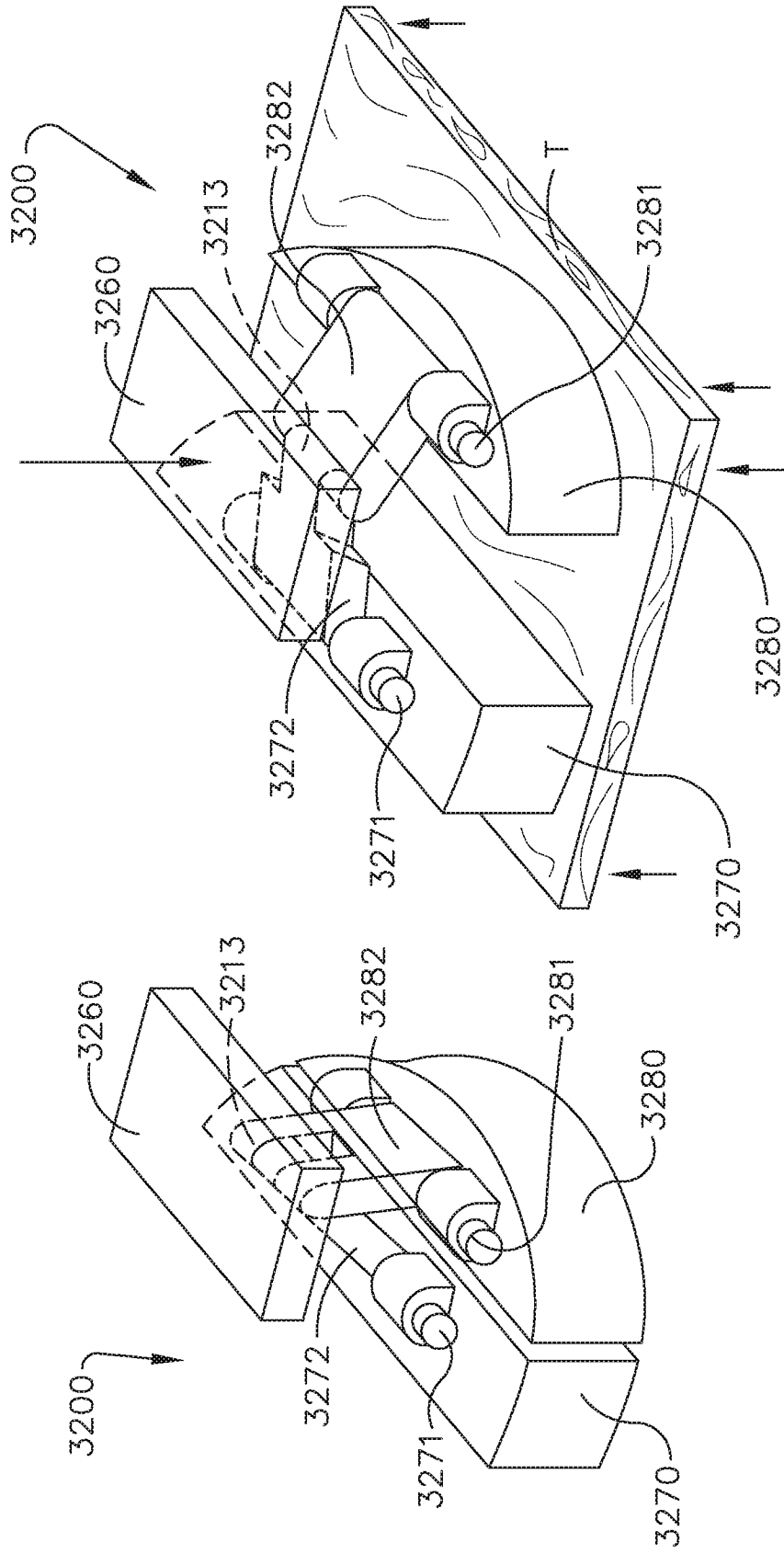

FIG. 58

FIG. 57

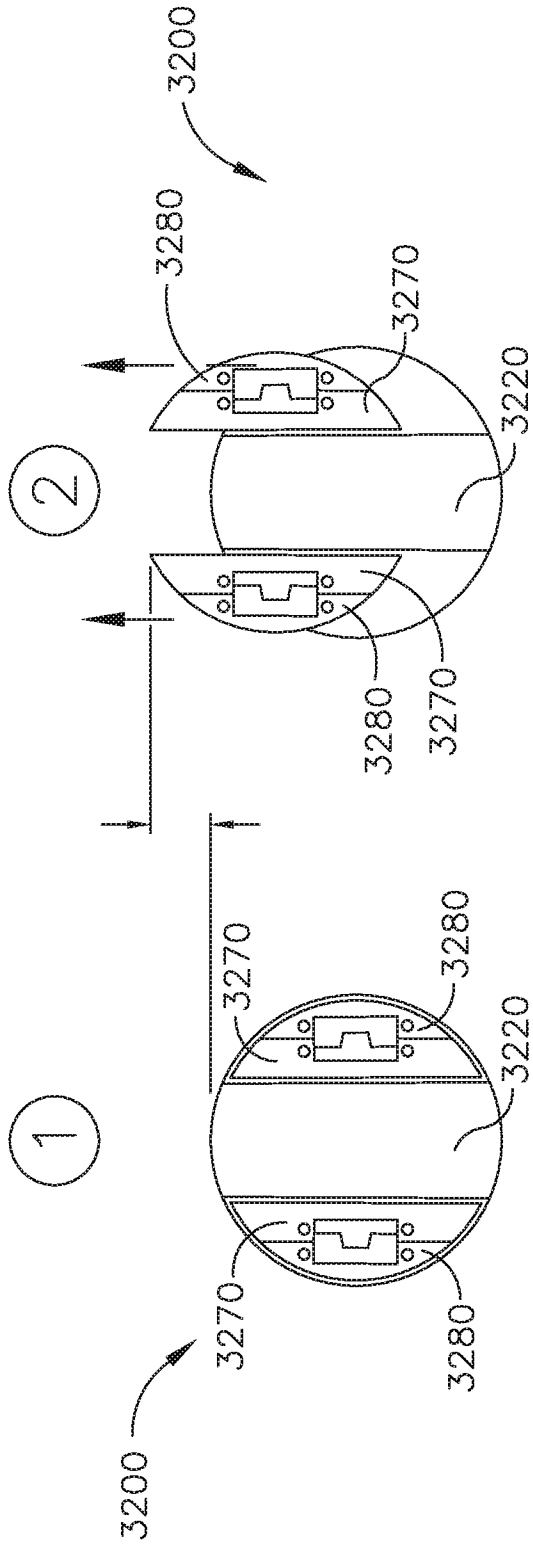

FIG. 59A

FIG. 59B

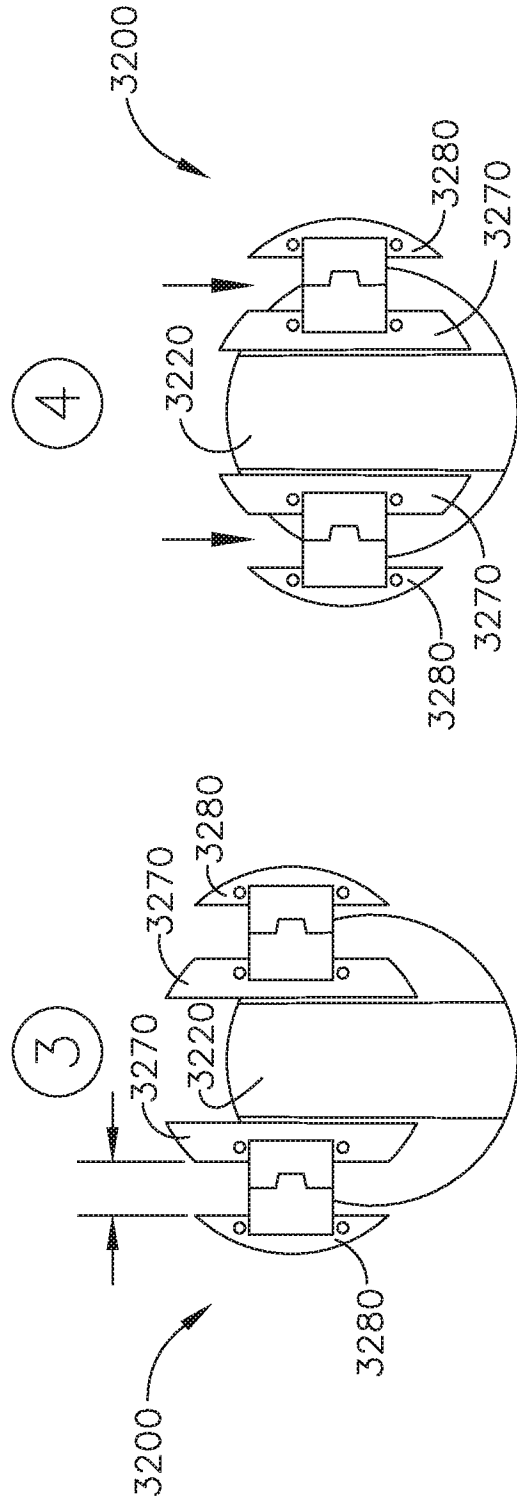
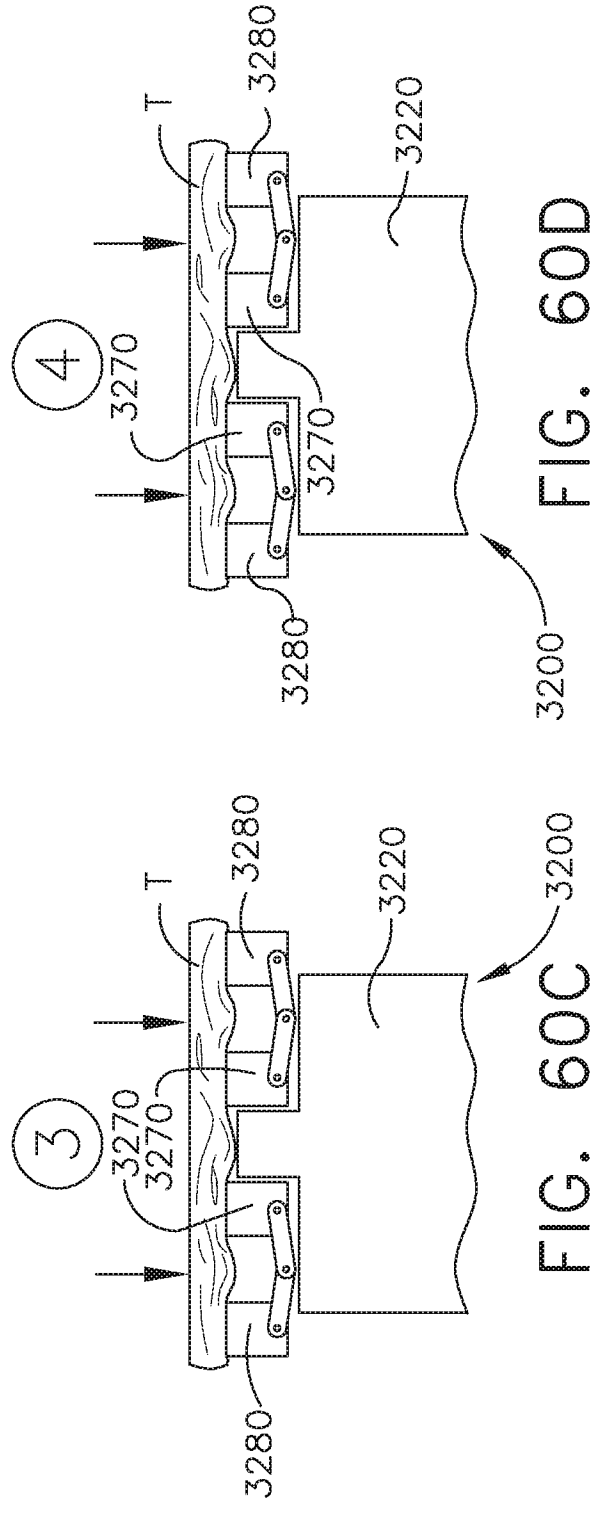
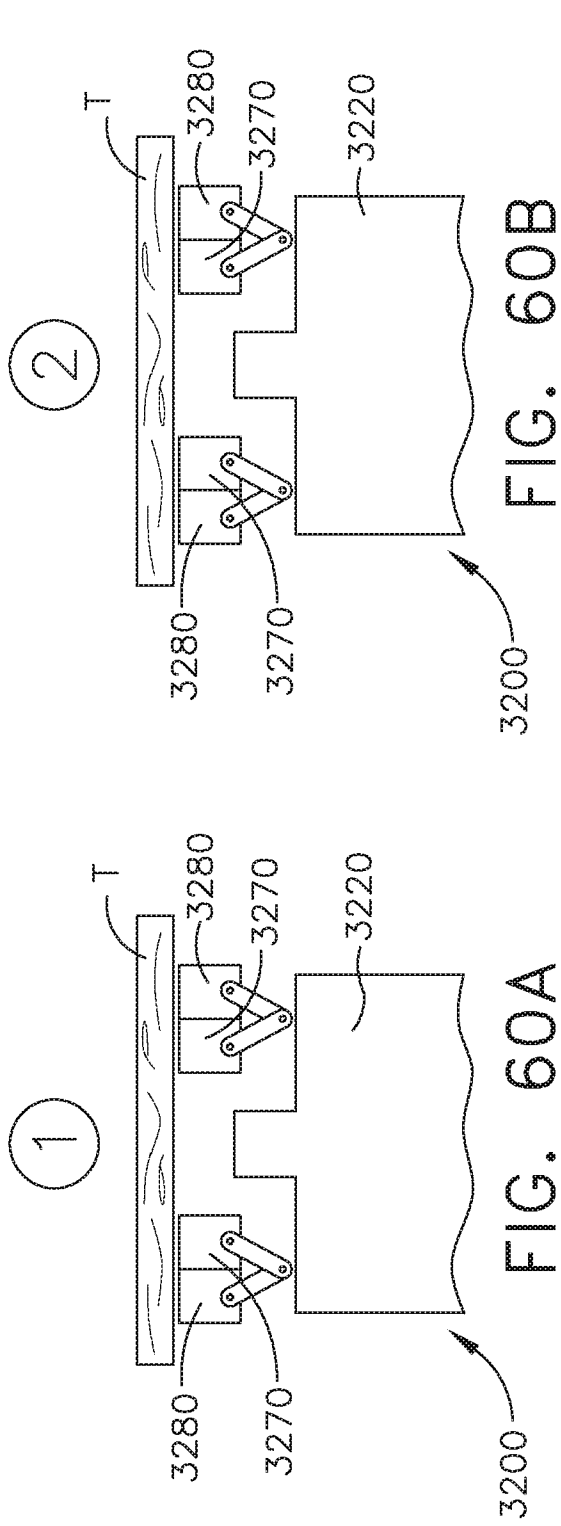

FIG. 59C

FIG. 59D



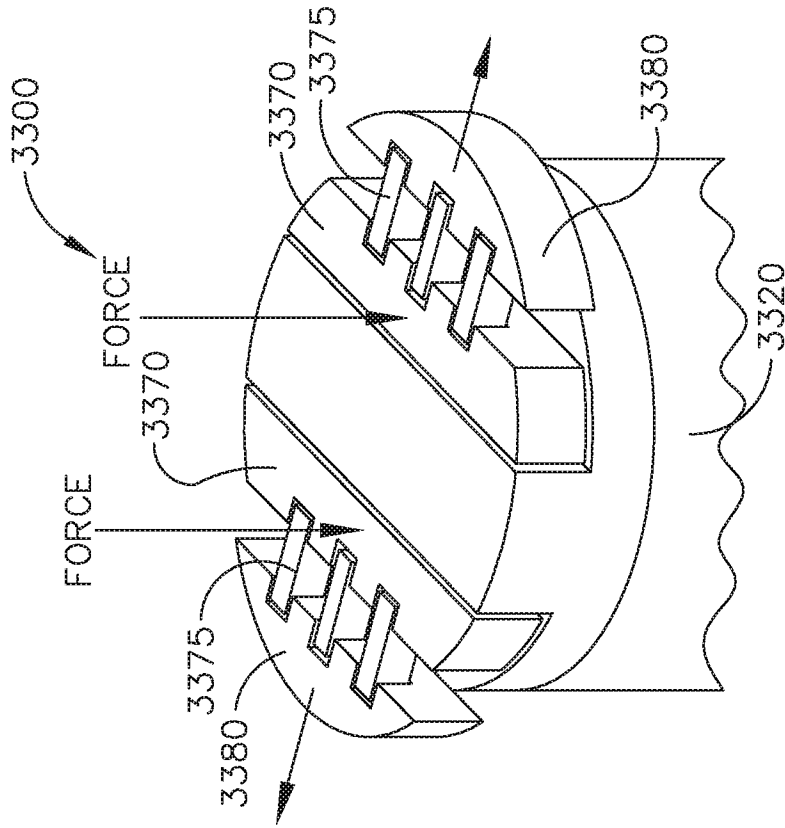

FIG. 61

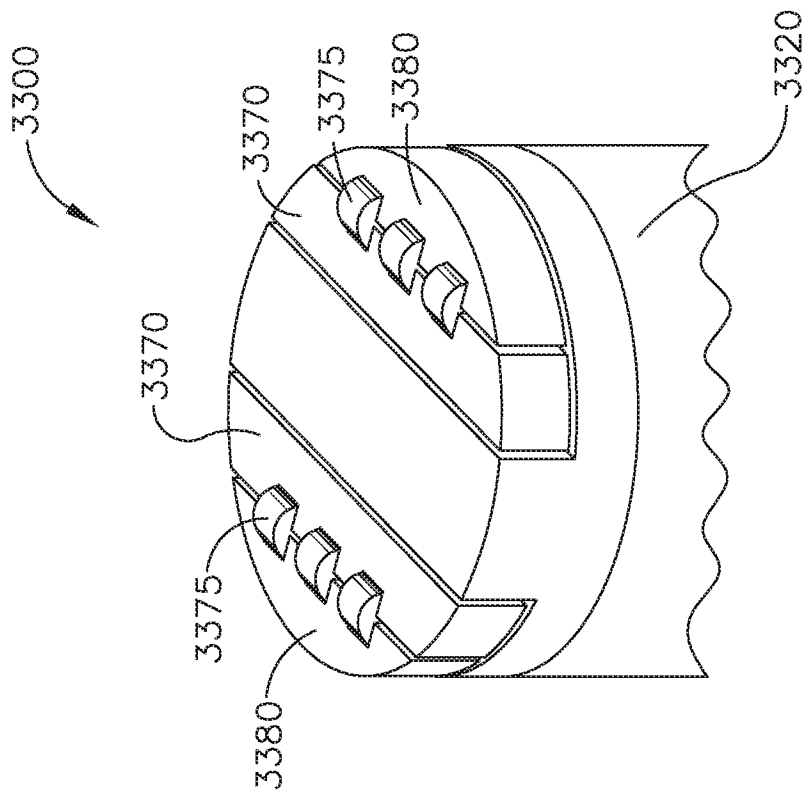
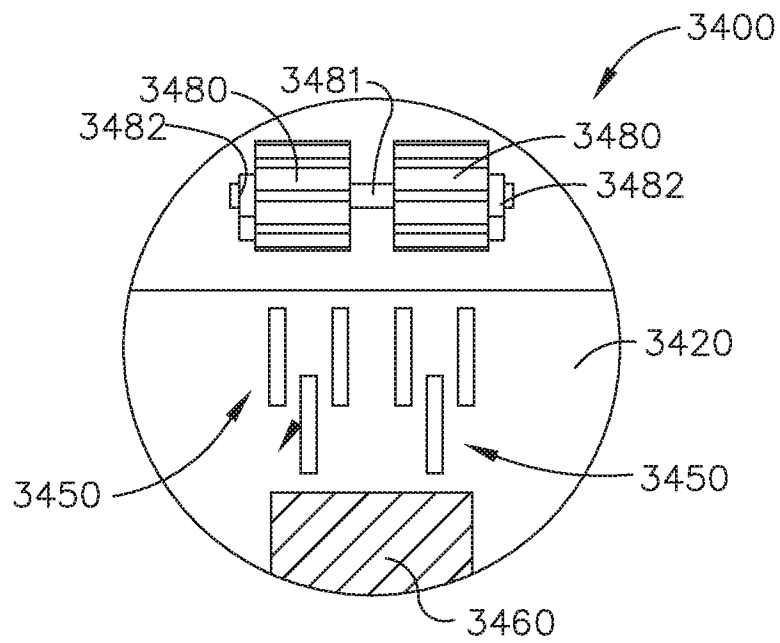
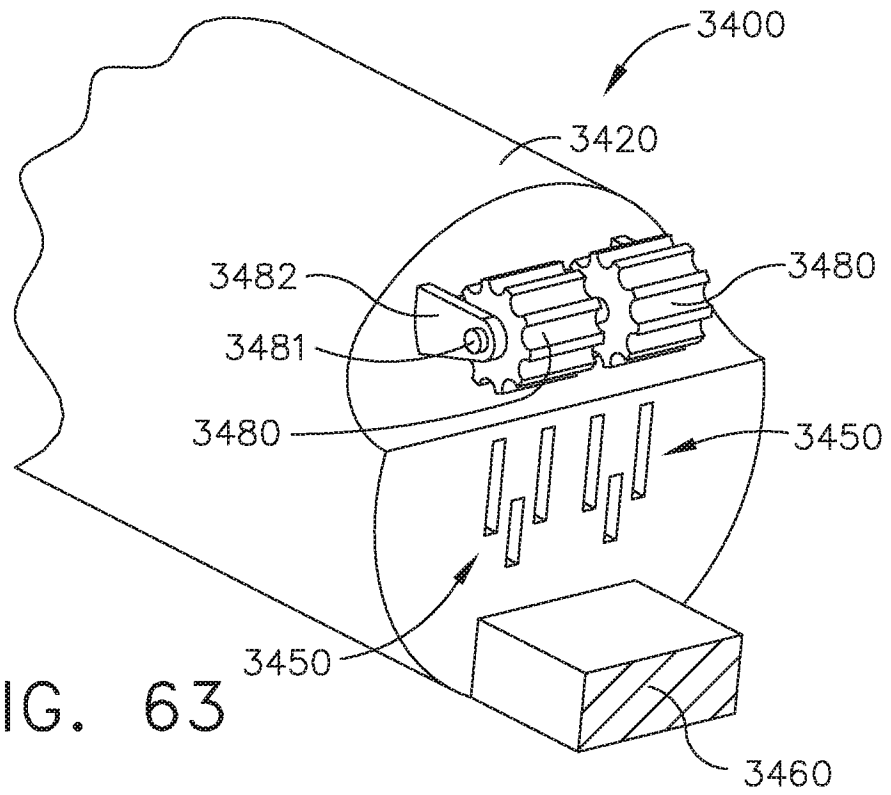

FIG. 62



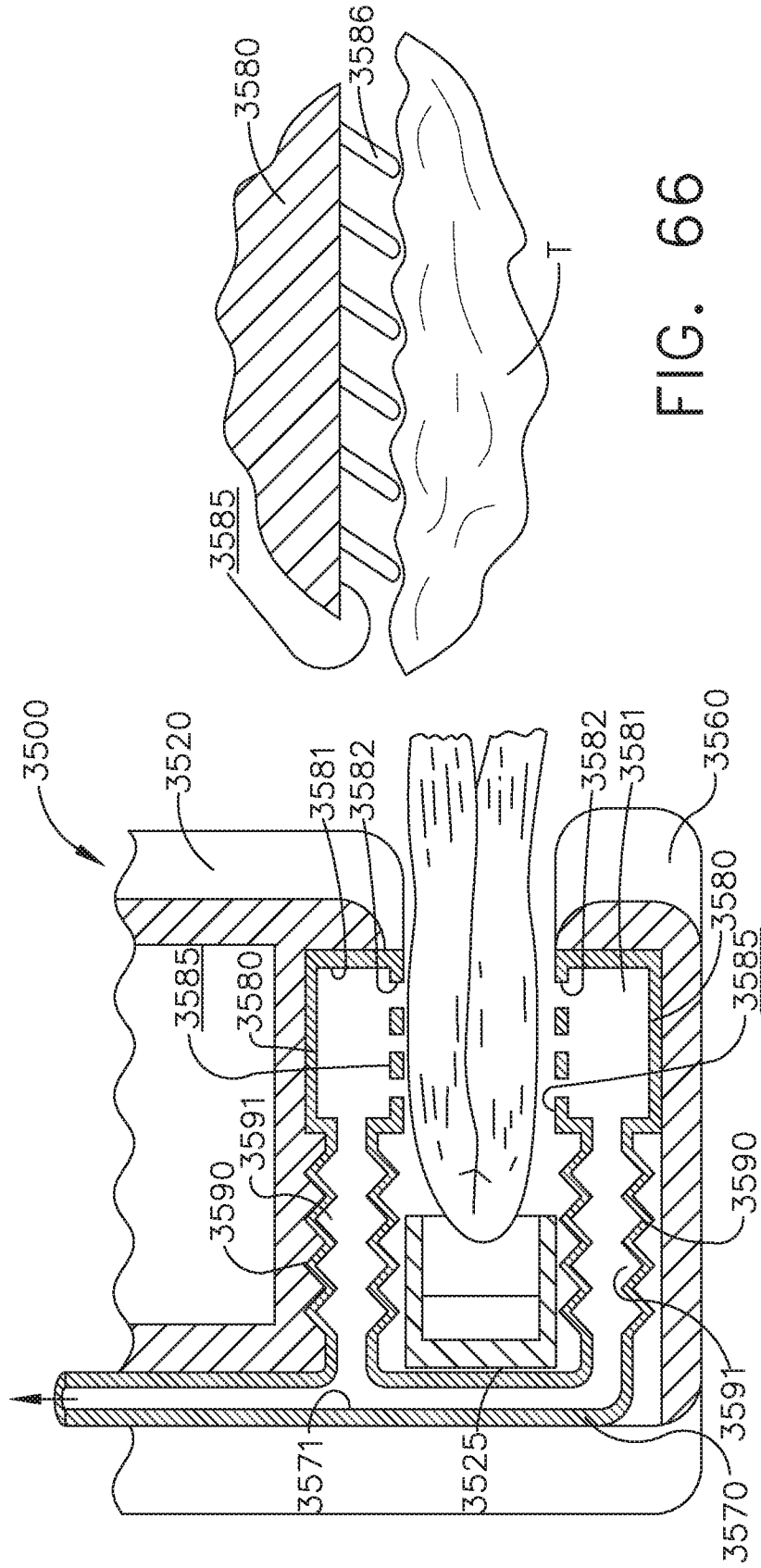

FIG. 66

FIG. 65

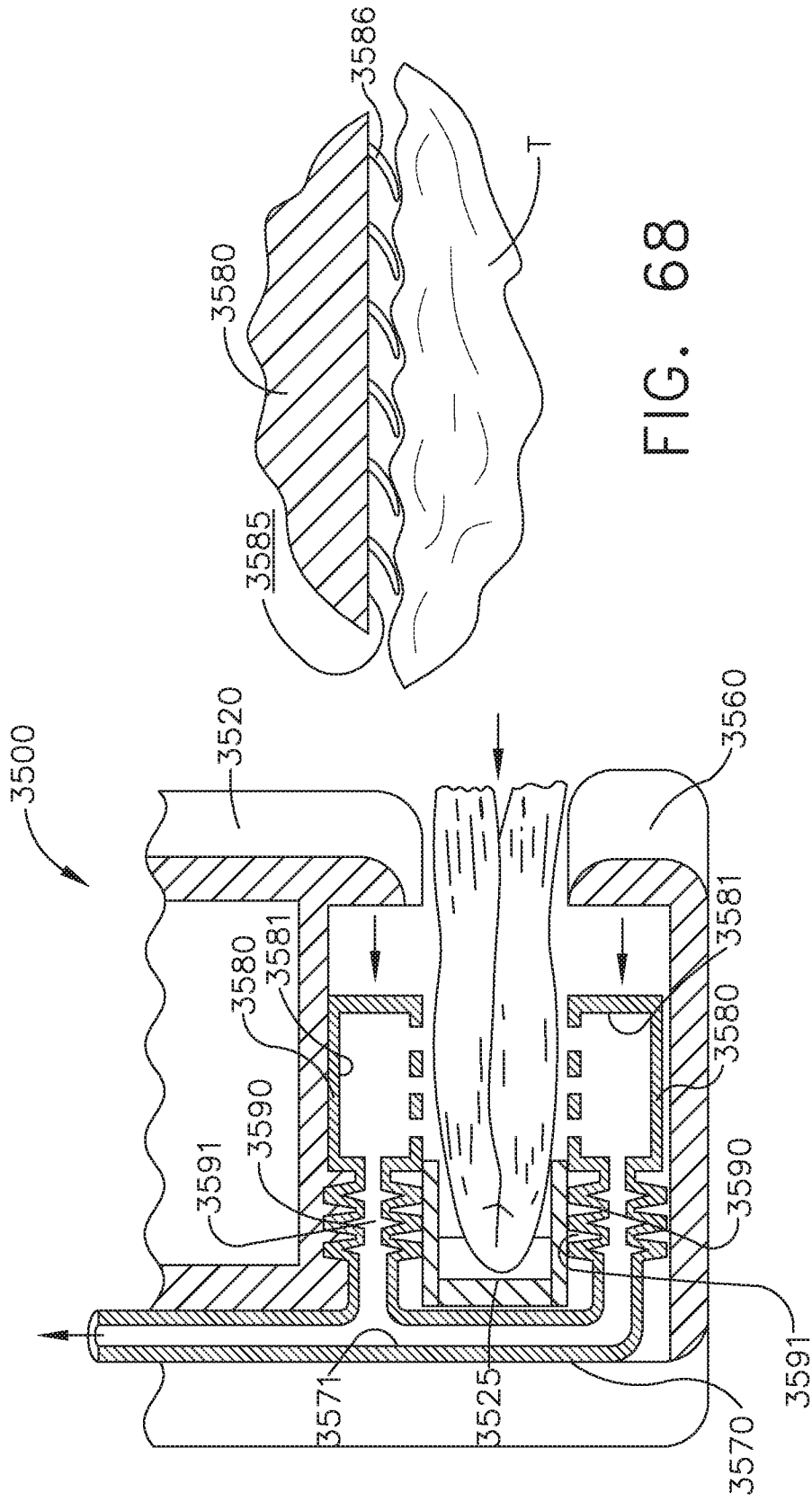

FIG. 68

FIG. 67

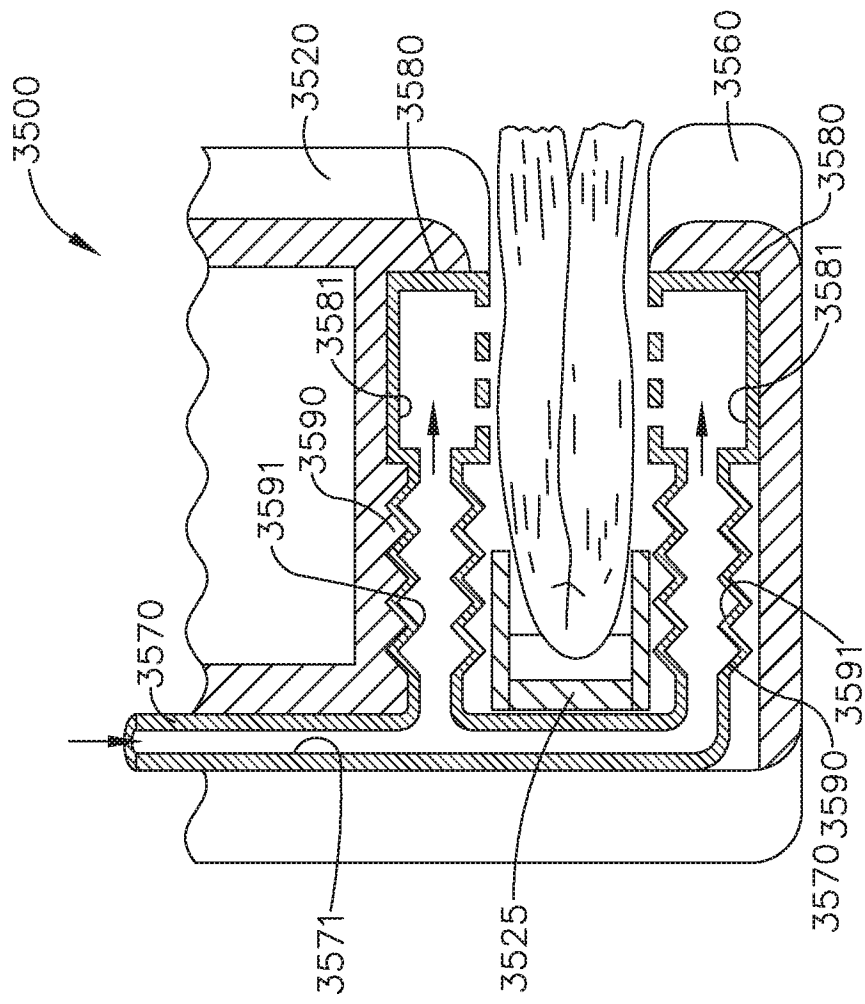

FIG. 69

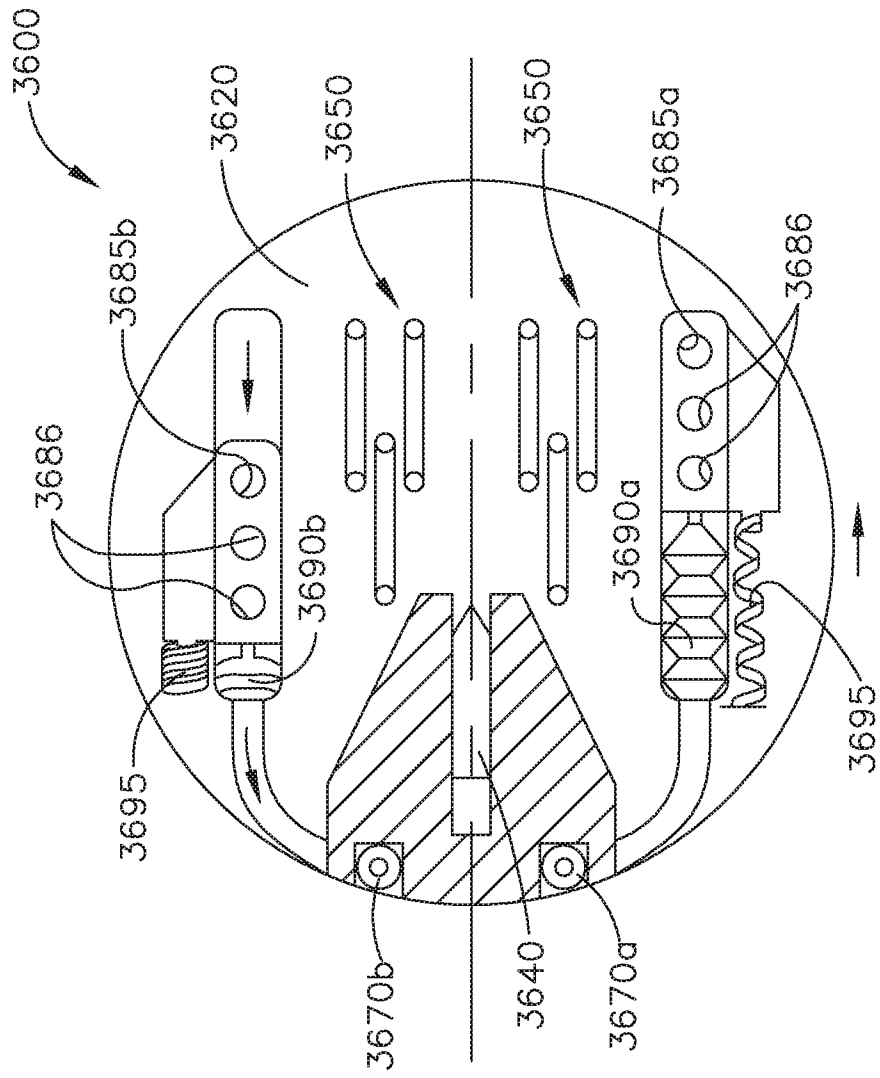

FIG. 70

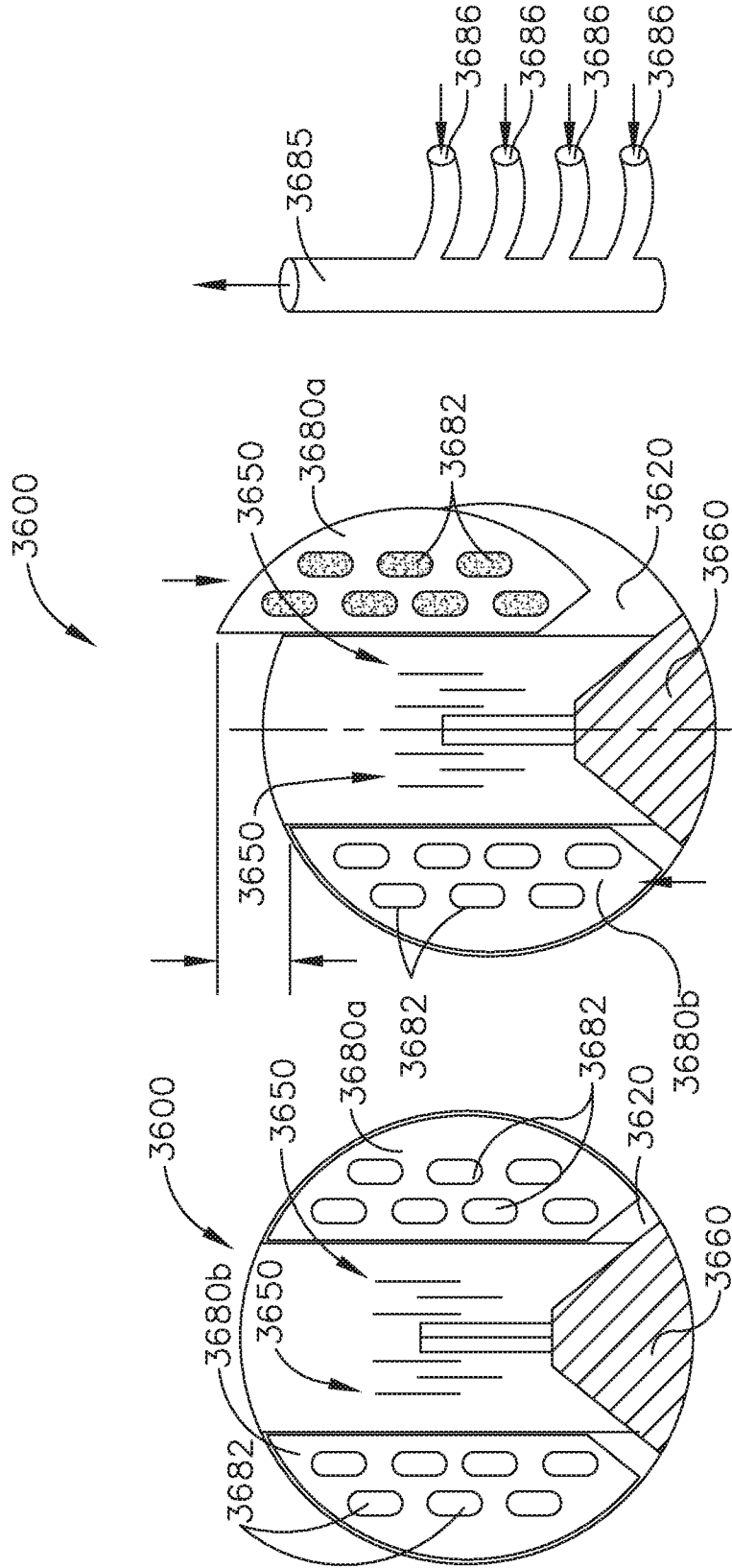

FIG. 73

FIG. 72

FIG. 71

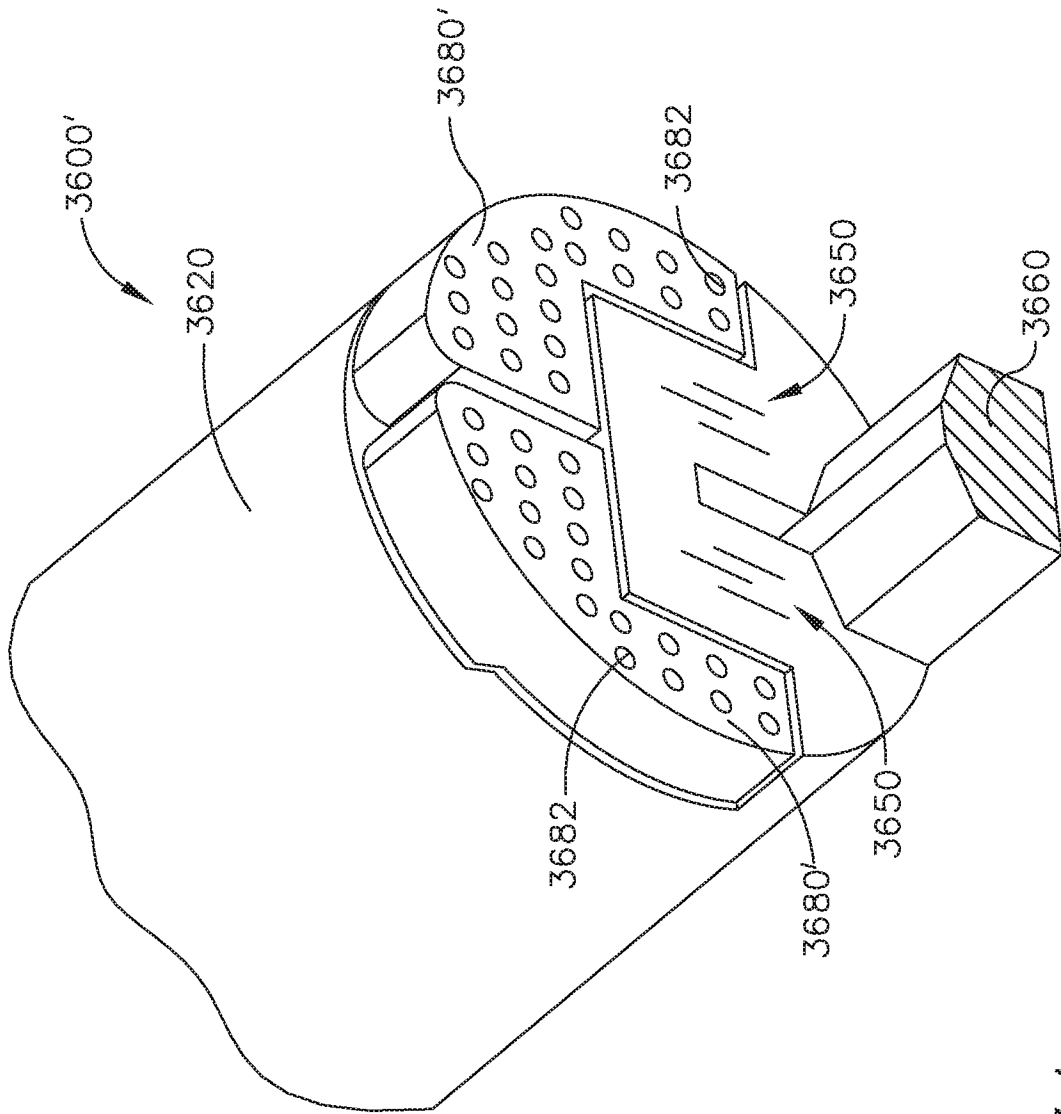

FIG. 74

FIG. 75A

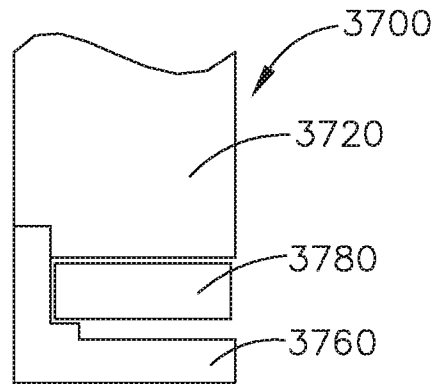

FIG. 75B

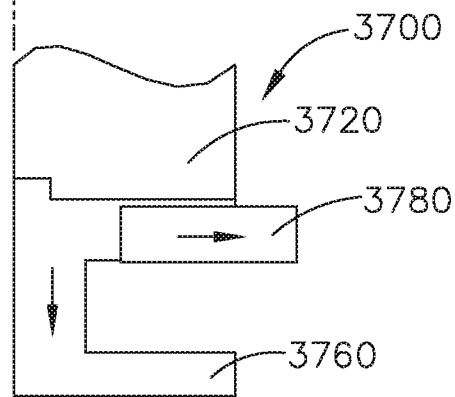

FIG. 75C

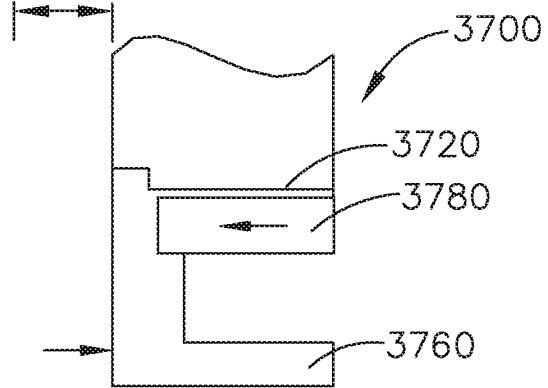
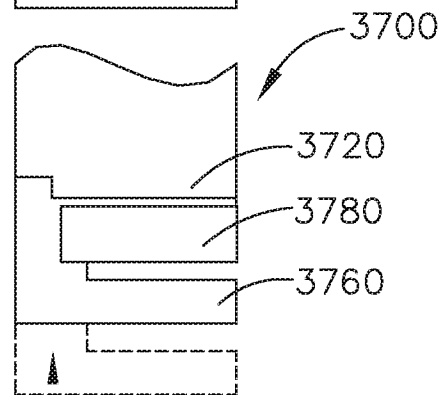

FIG. 75D



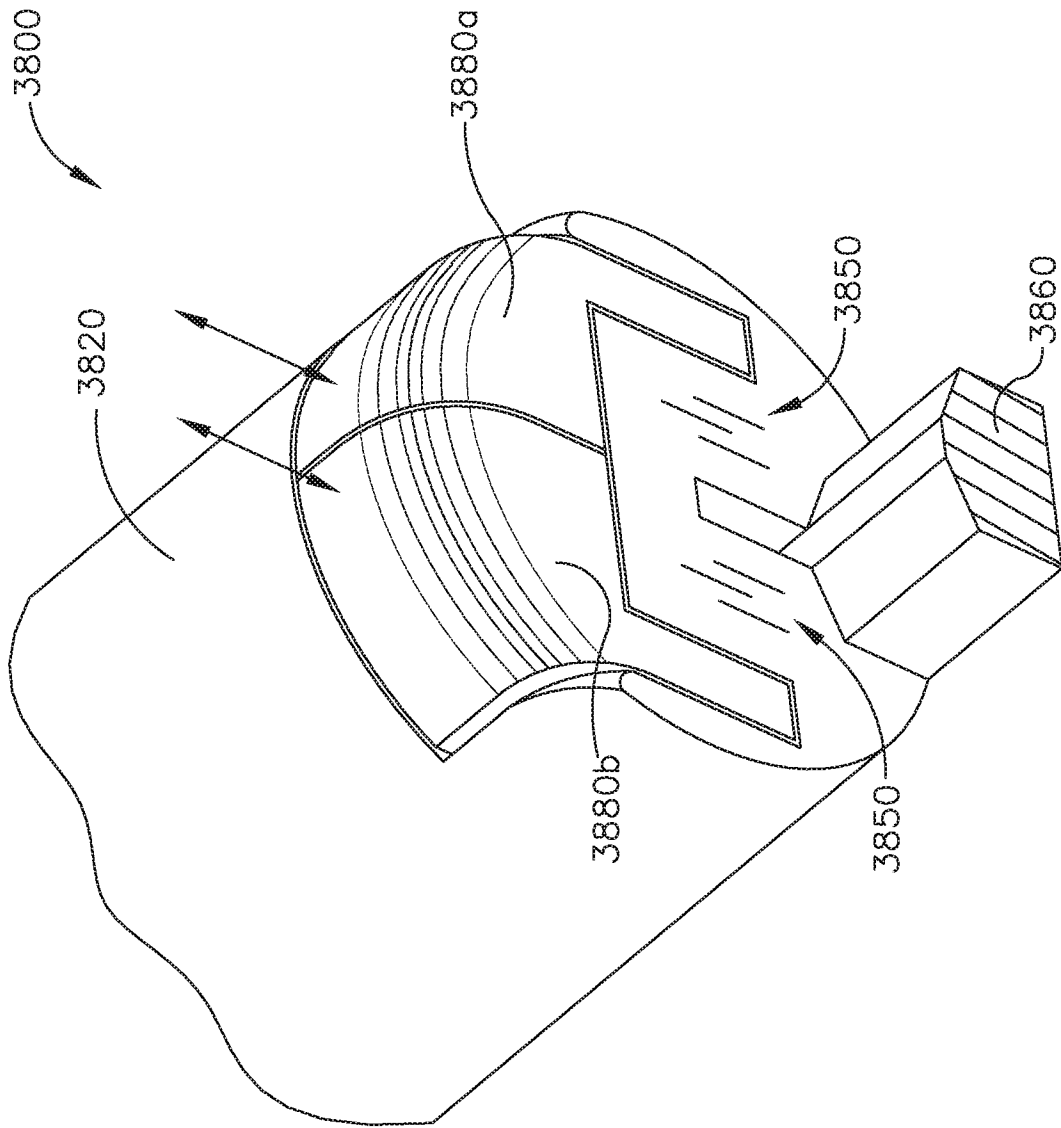
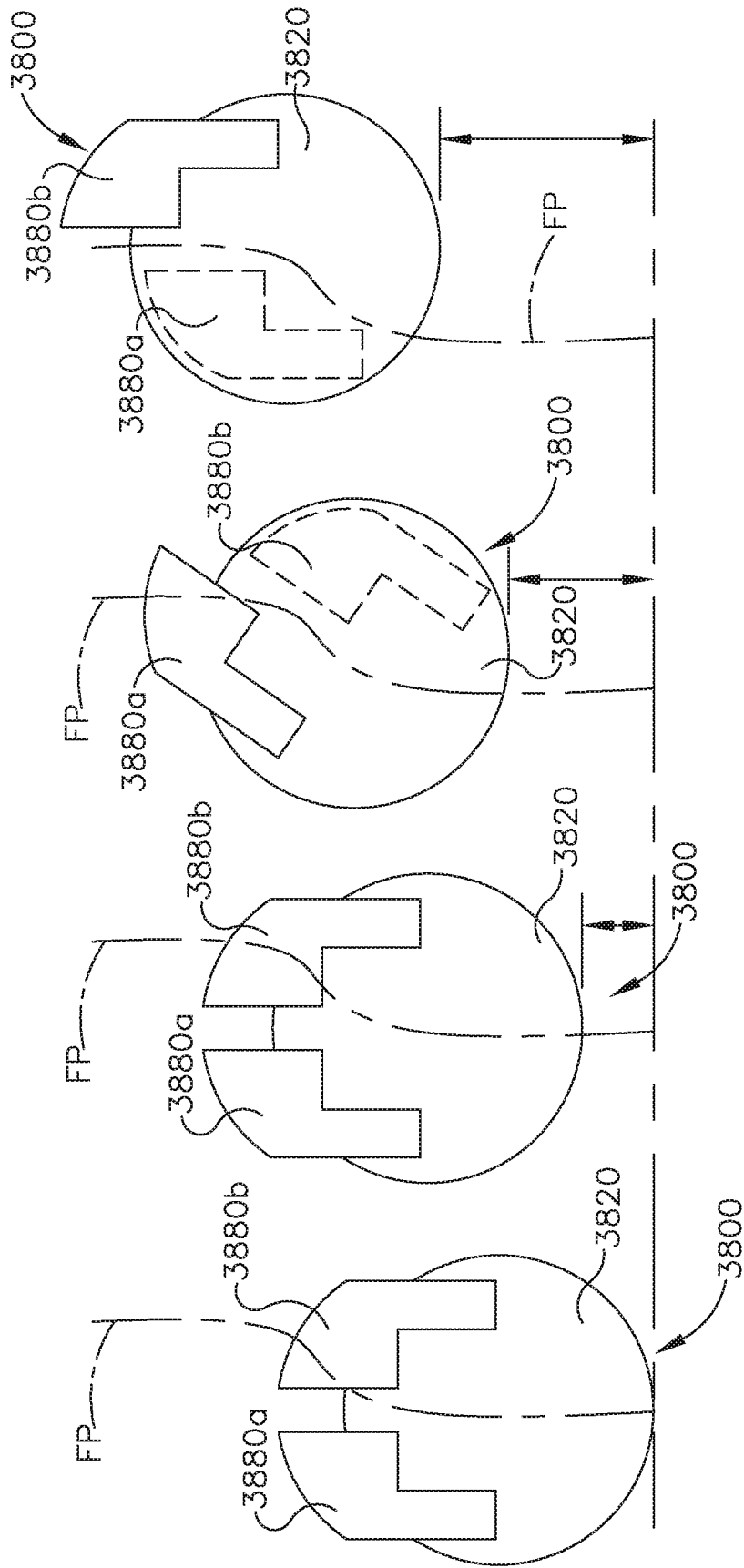

FIG. 76



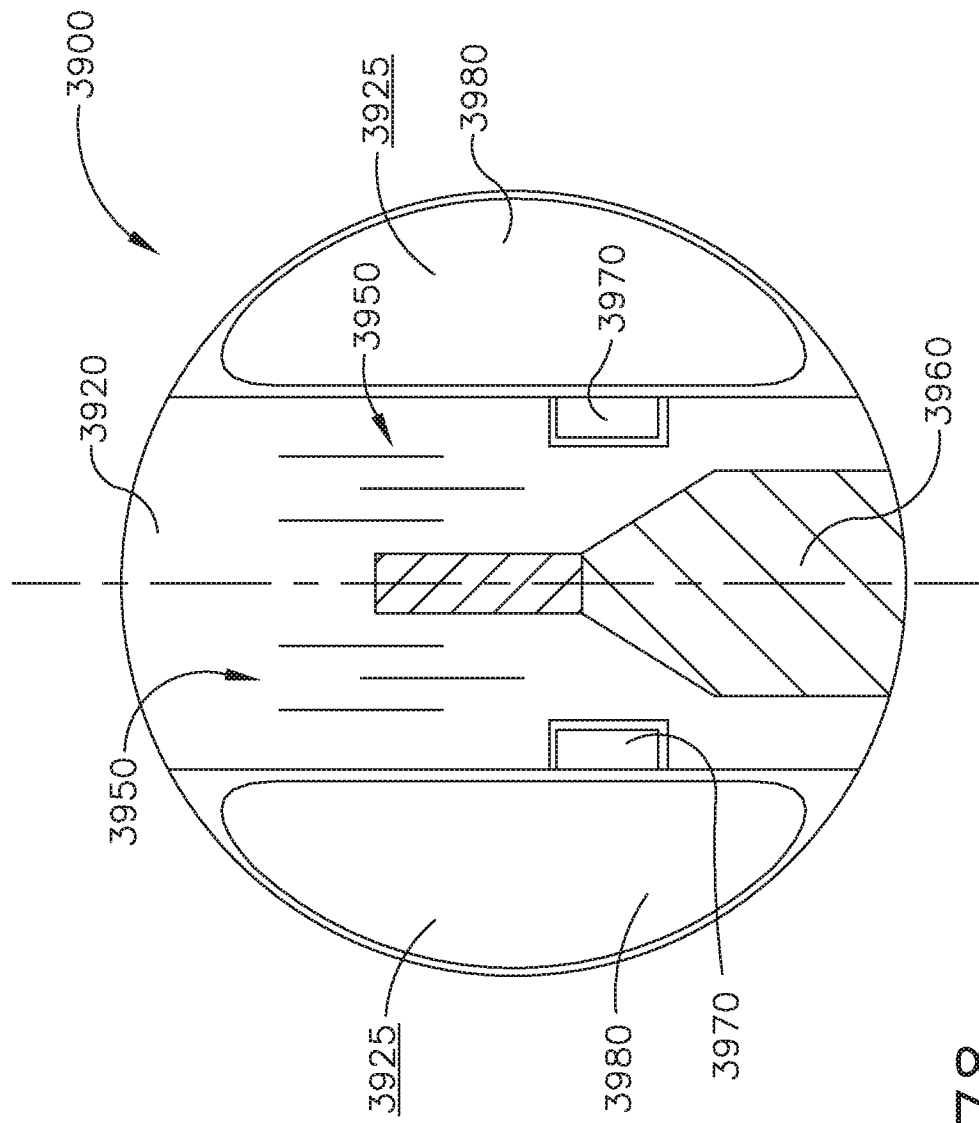

FIG. 78

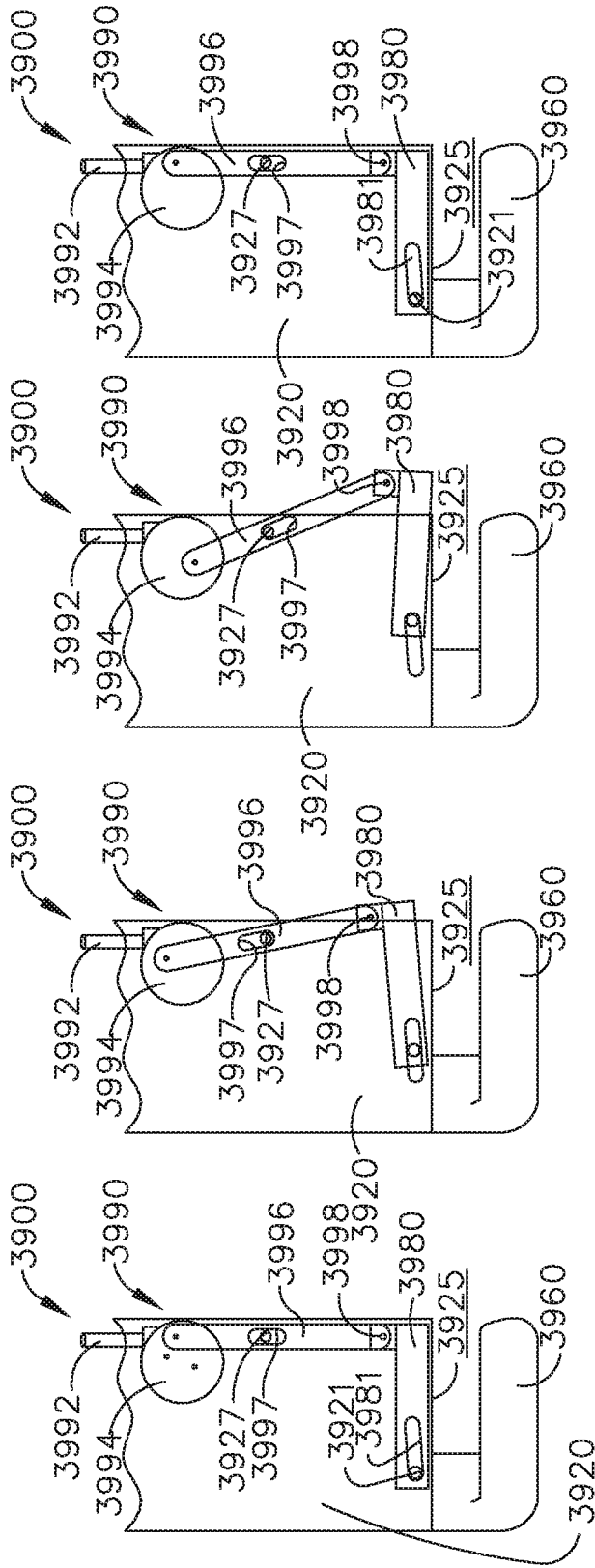

FIG. 79 FIG. 80 FIG. 81 FIG. 82



FIG. 79A FIG. 80A FIG. 81A FIG. 82A

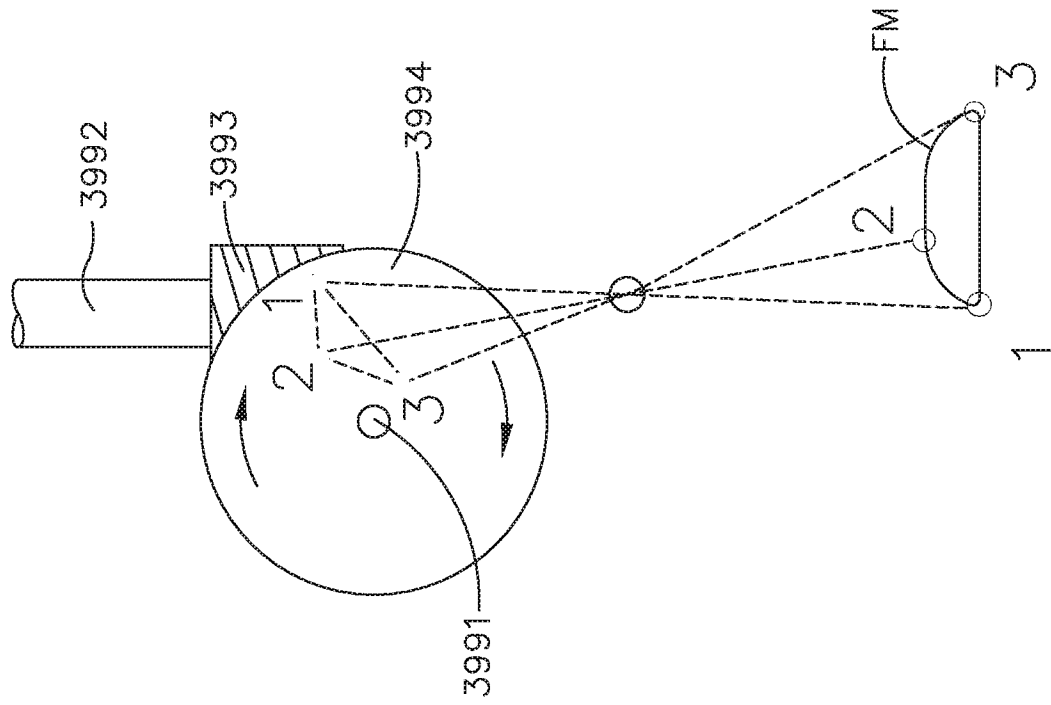

FIG. 84

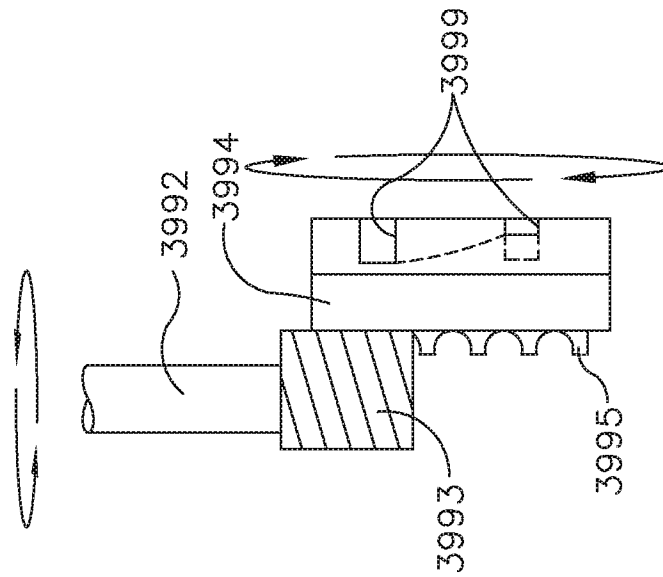

FIG. 83

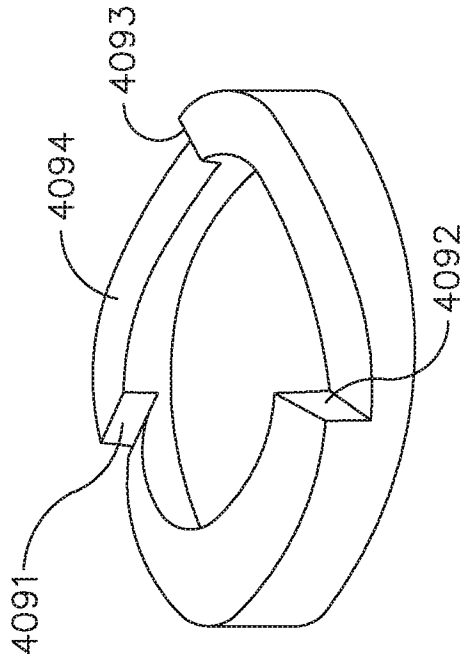

FIG. 85

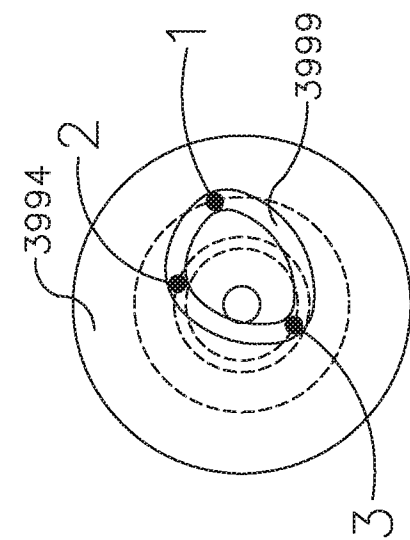

FIG. 86

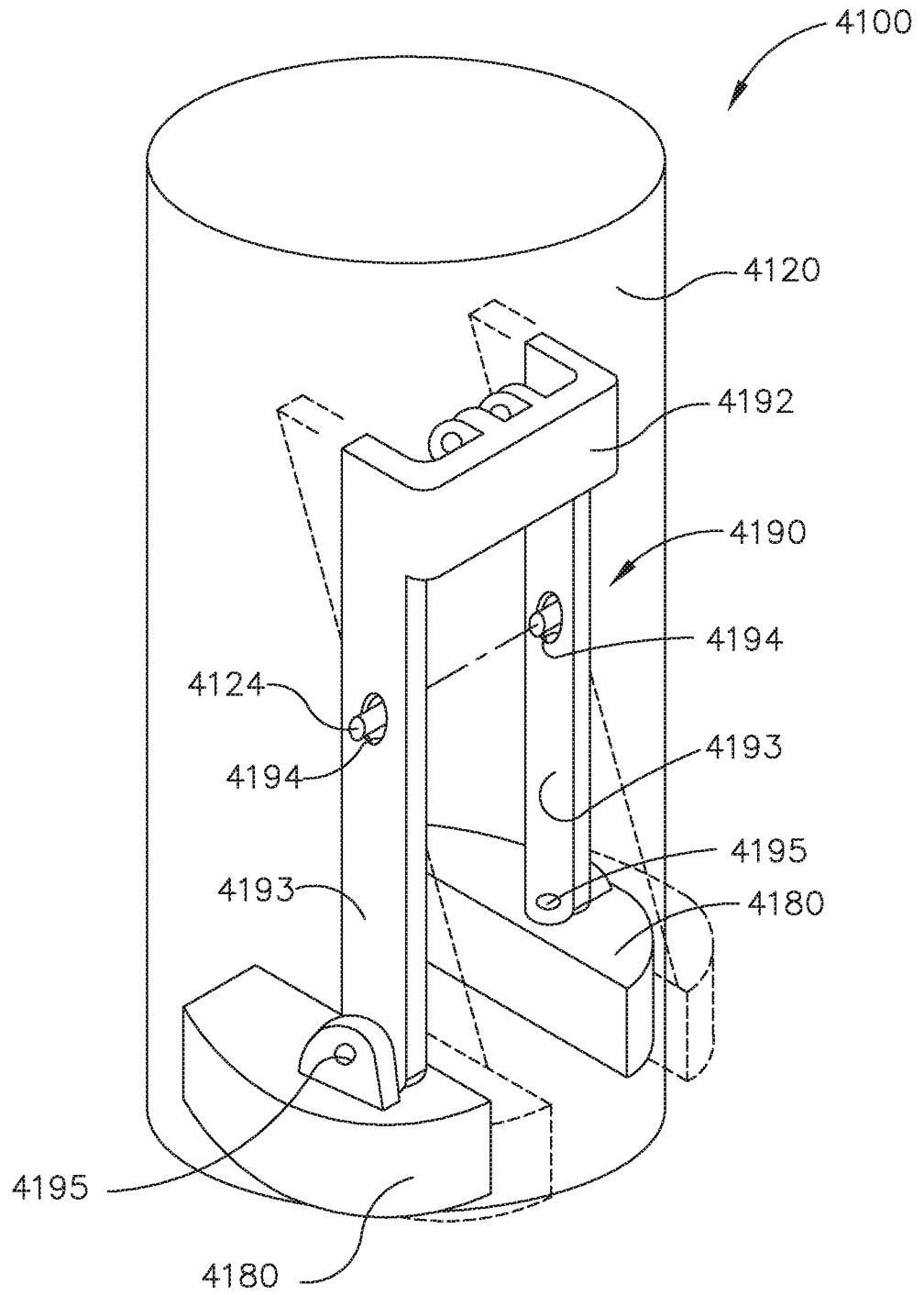

FIG. 87

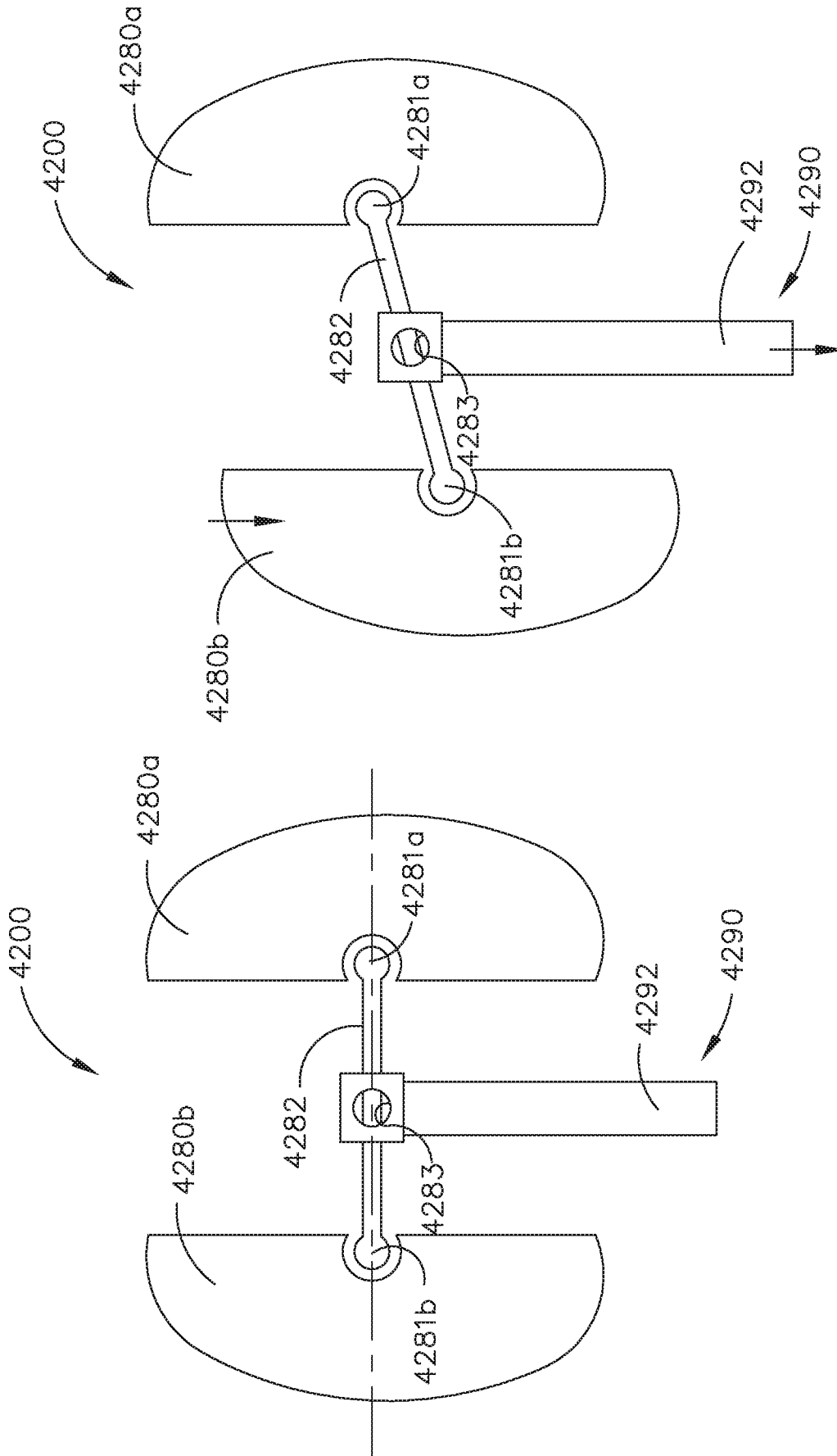

FIG. 89

FIG. 88

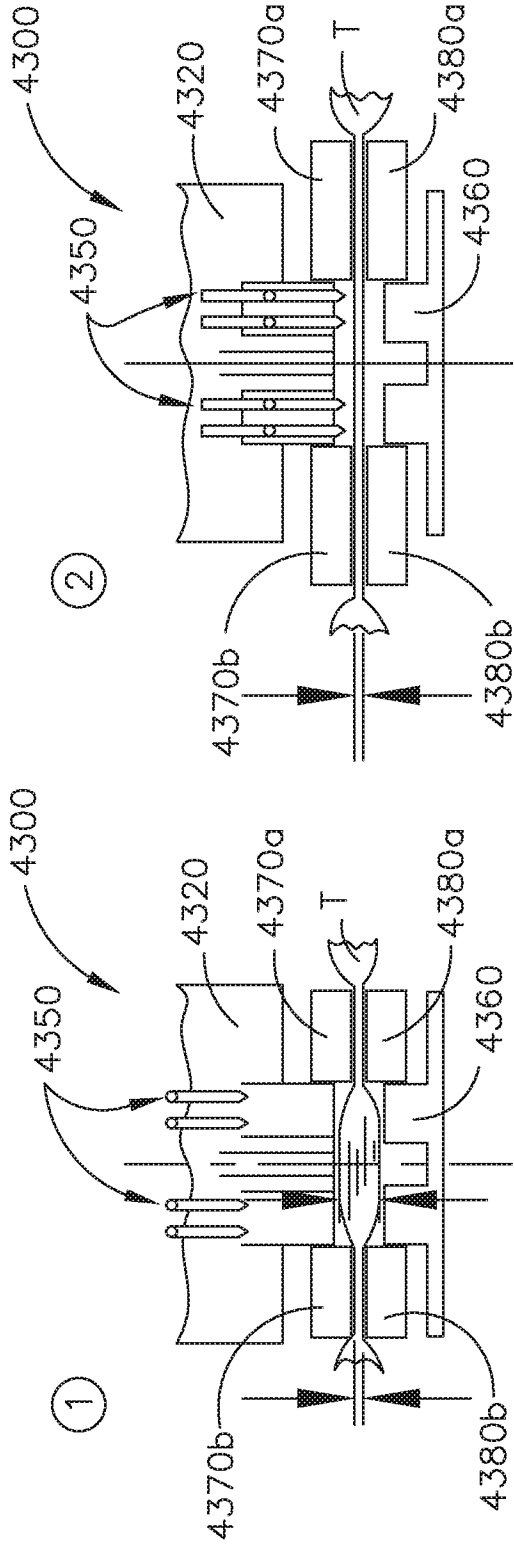

FIG. 90A

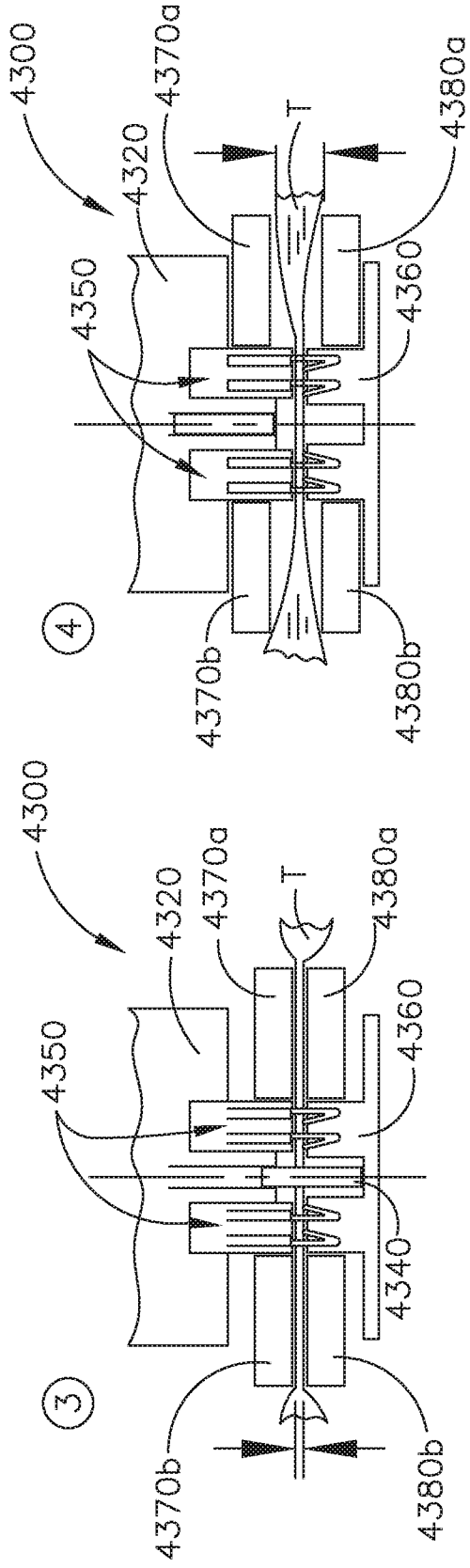

FIG. 90B

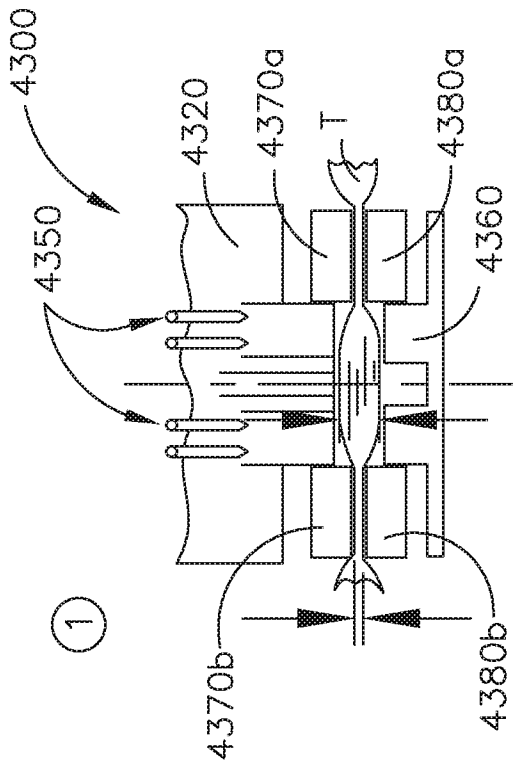

FIG. 90C

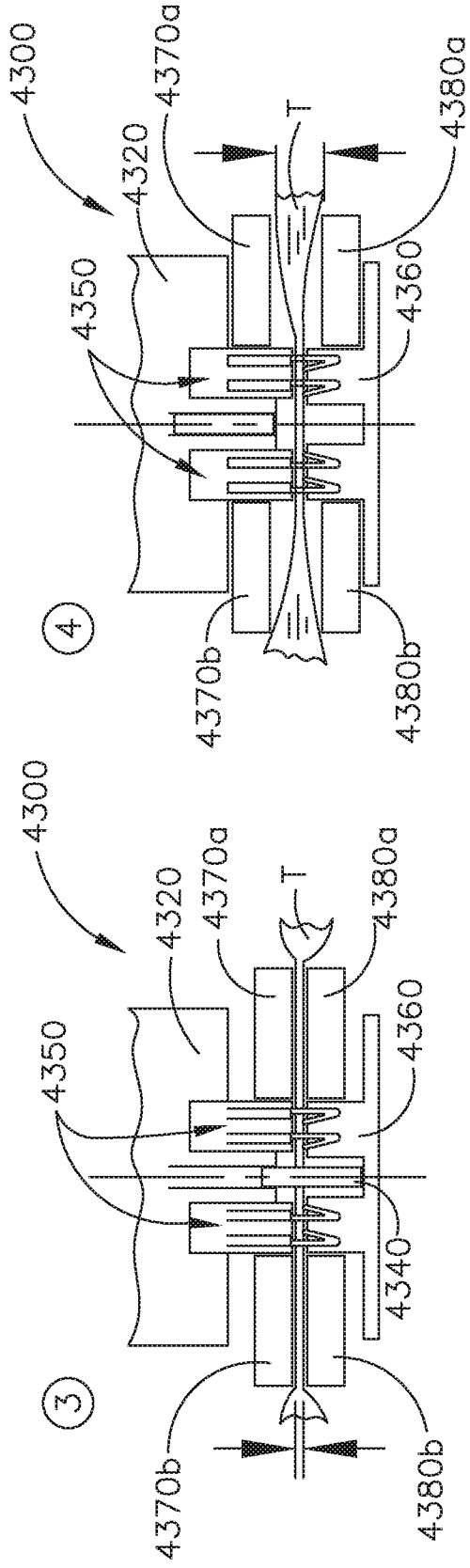

FIG. 90D

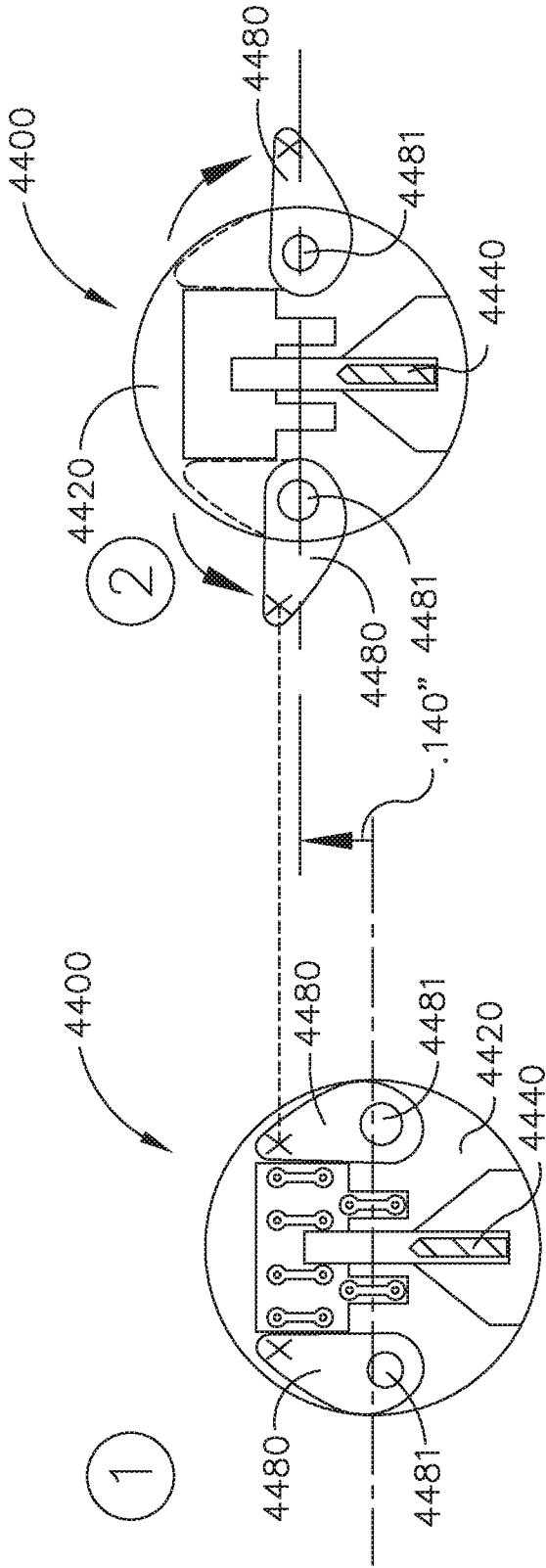

FIG. 91A

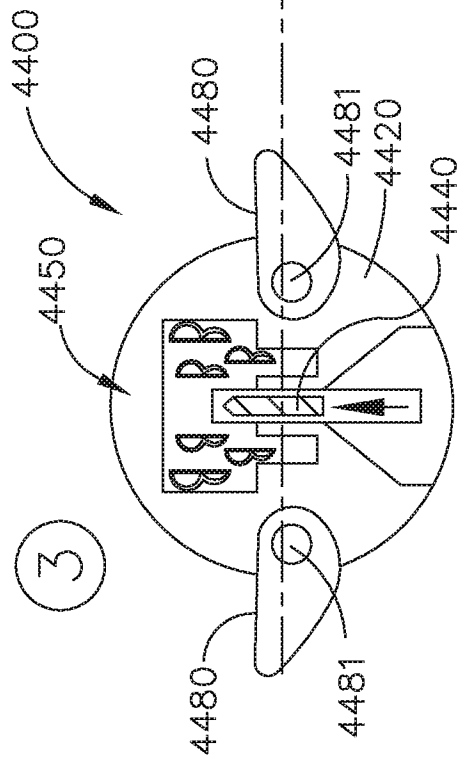

FIG. 91C

FIG. 91B

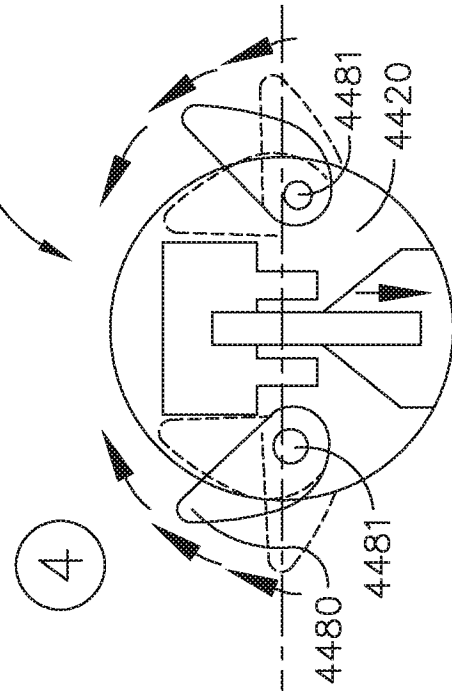

FIG. 91D

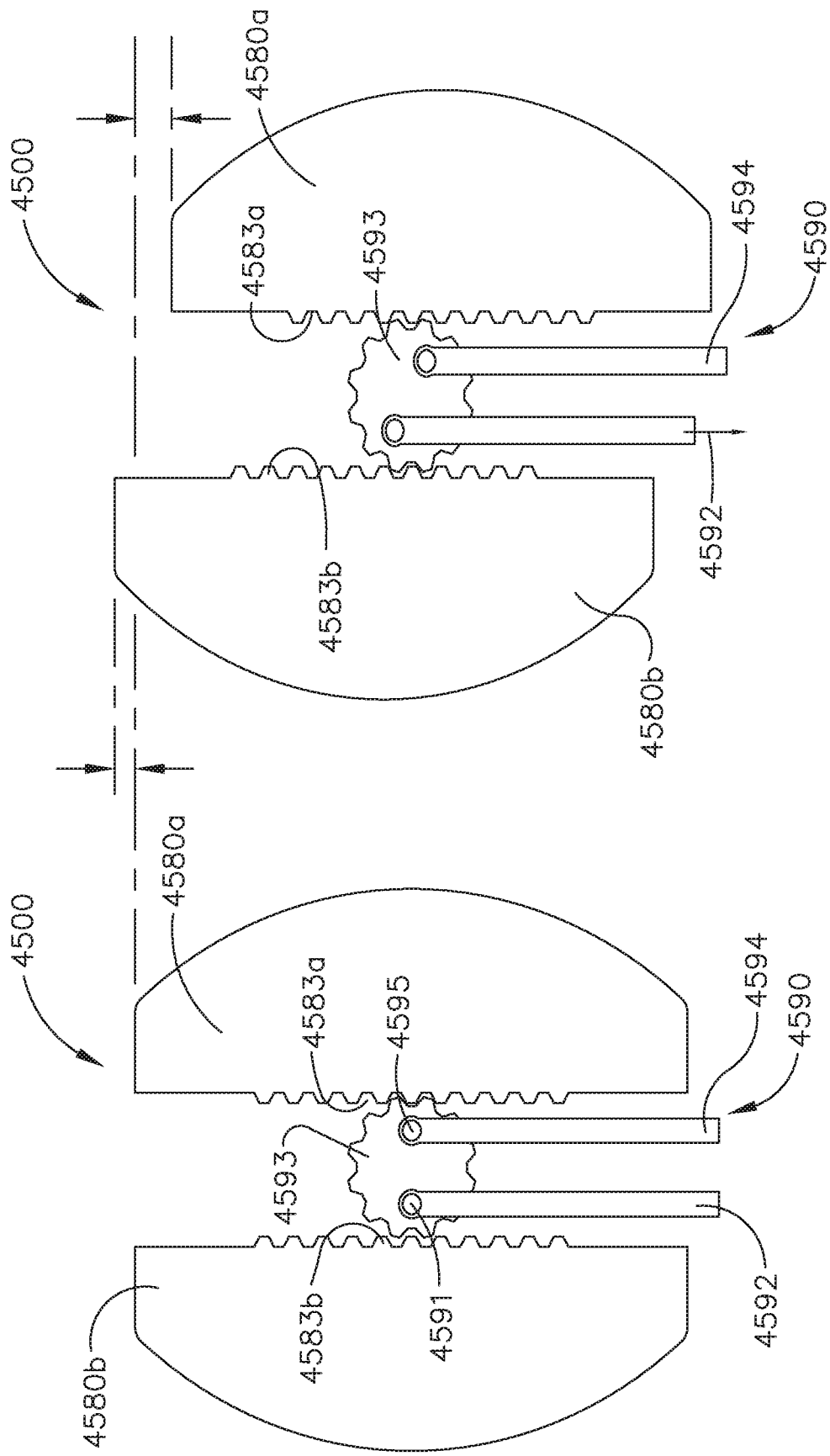

FIG. 93

FIG. 92

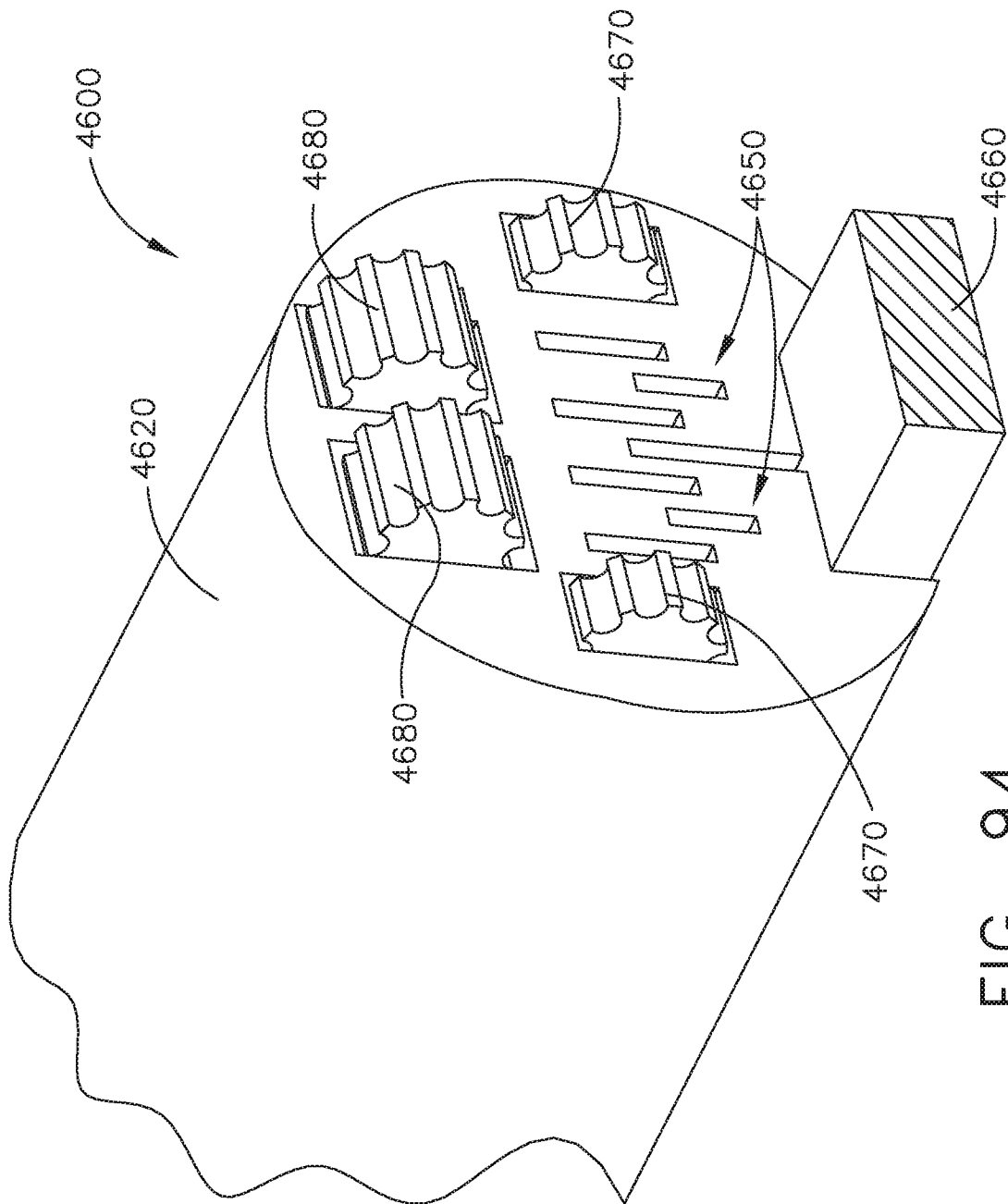

FIG. 94

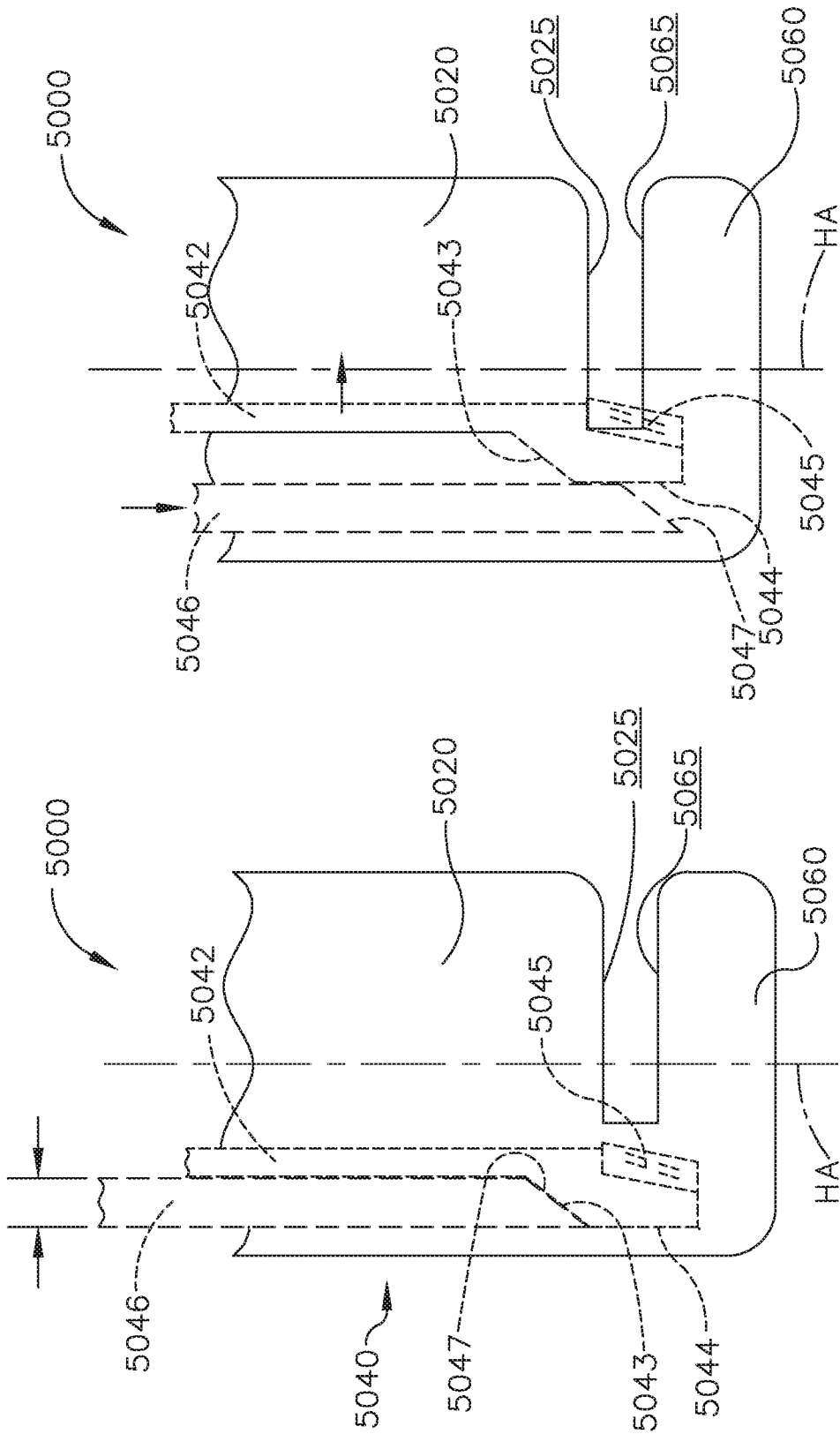

FIG. 96

FIG. 95

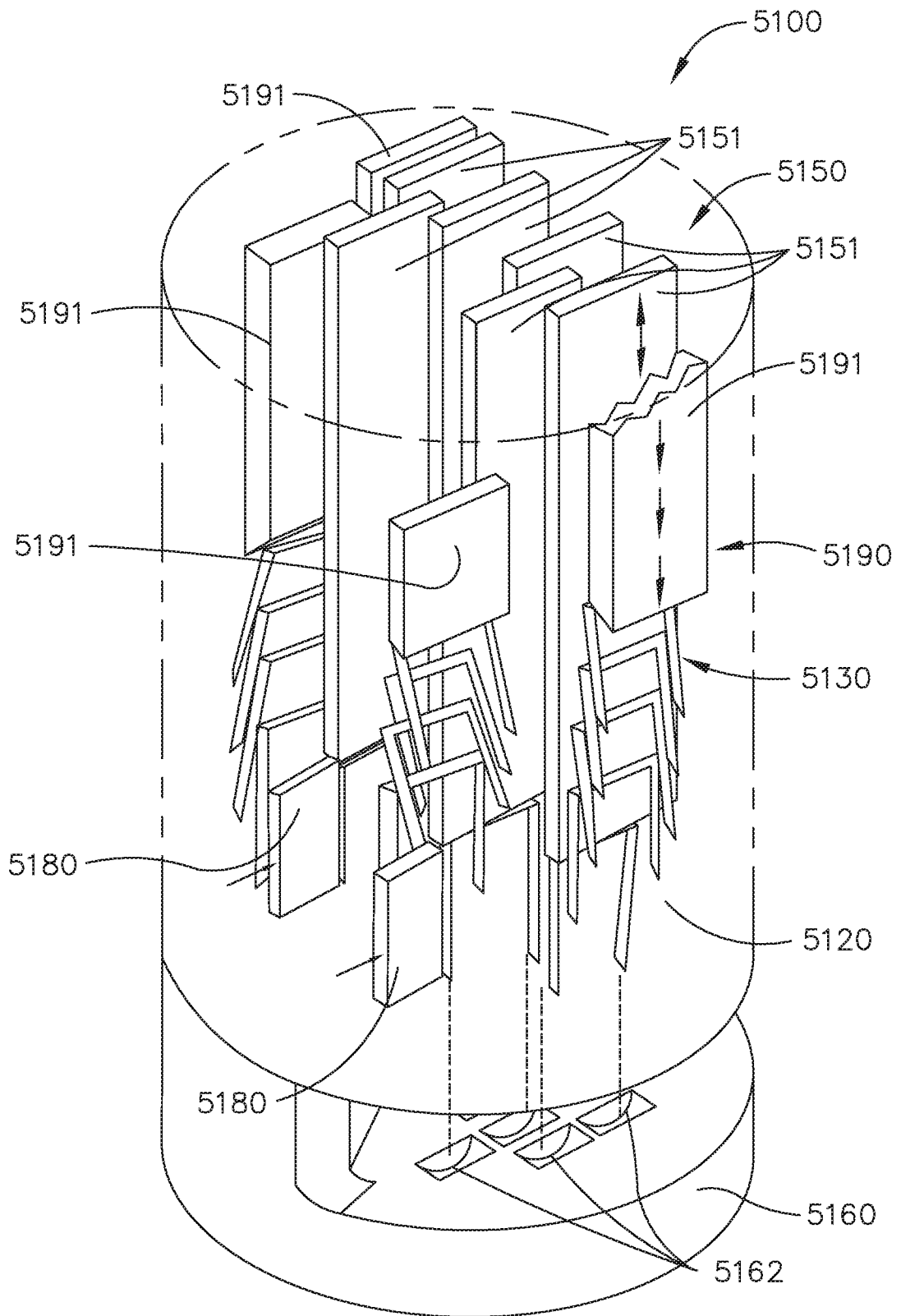

FIG. 97

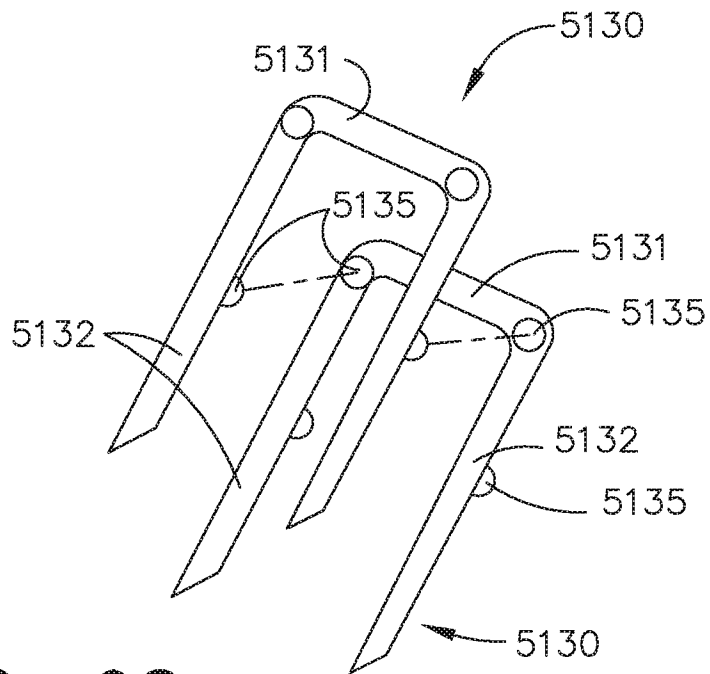

FIG. 98

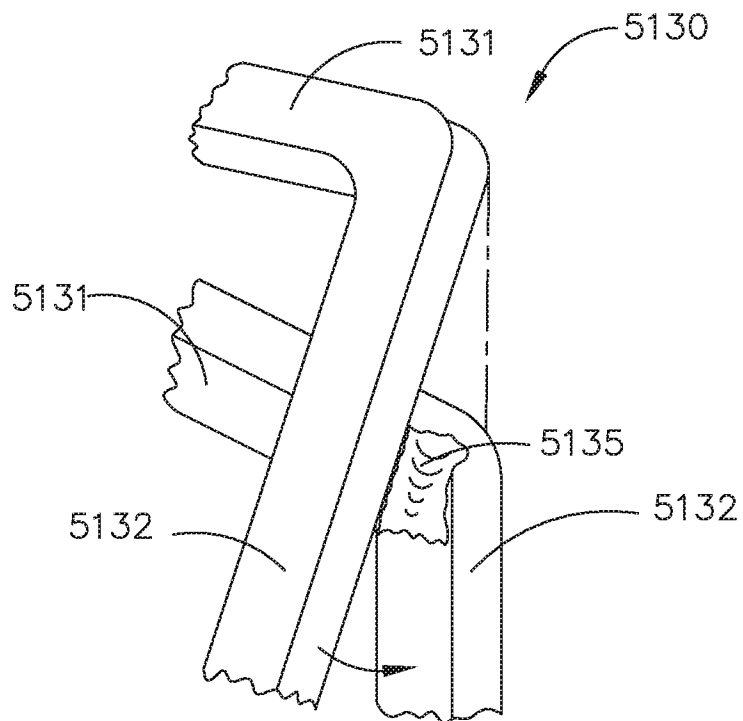

FIG. 99

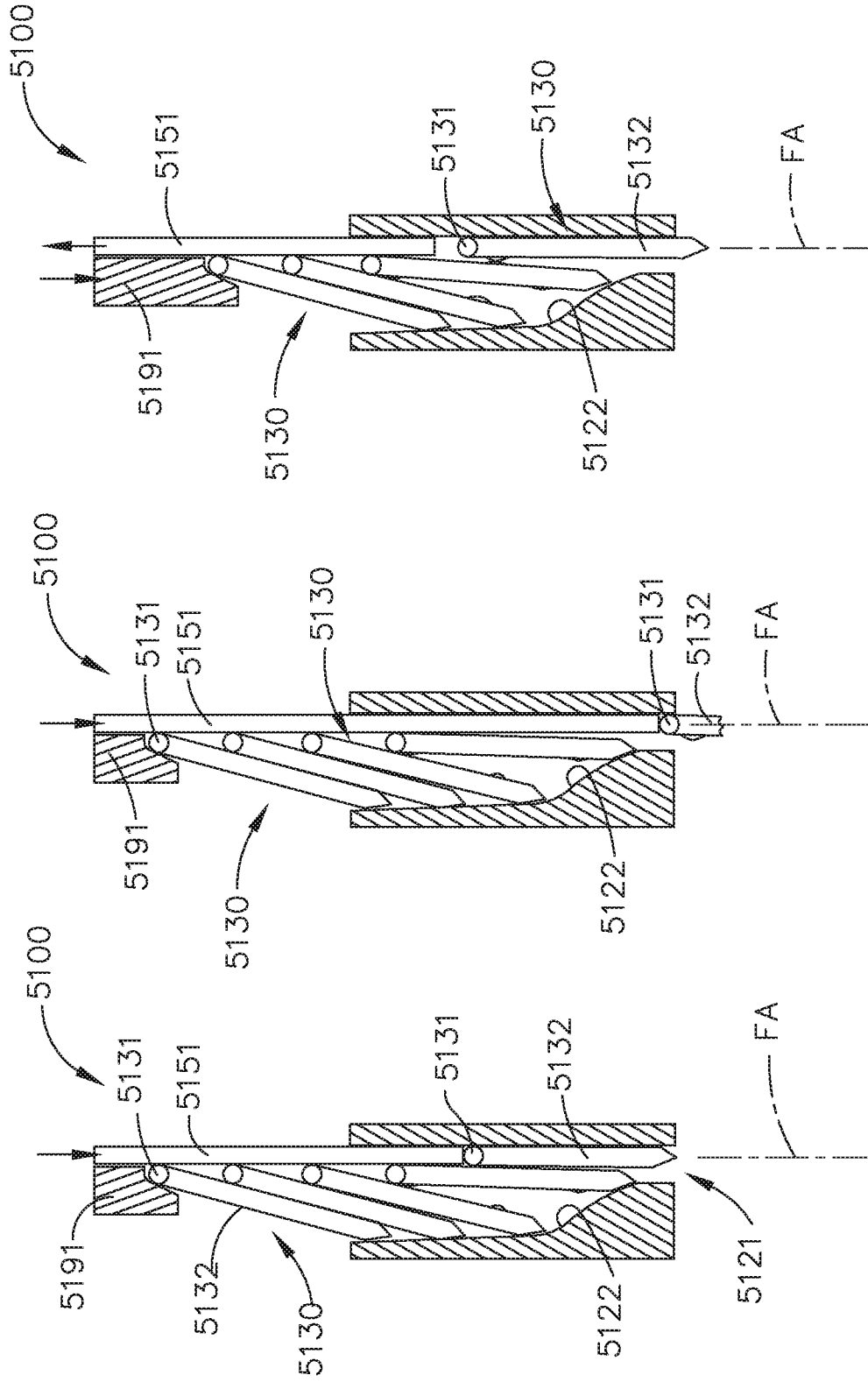

FIG. 102

FIG. 101

FIG. 100

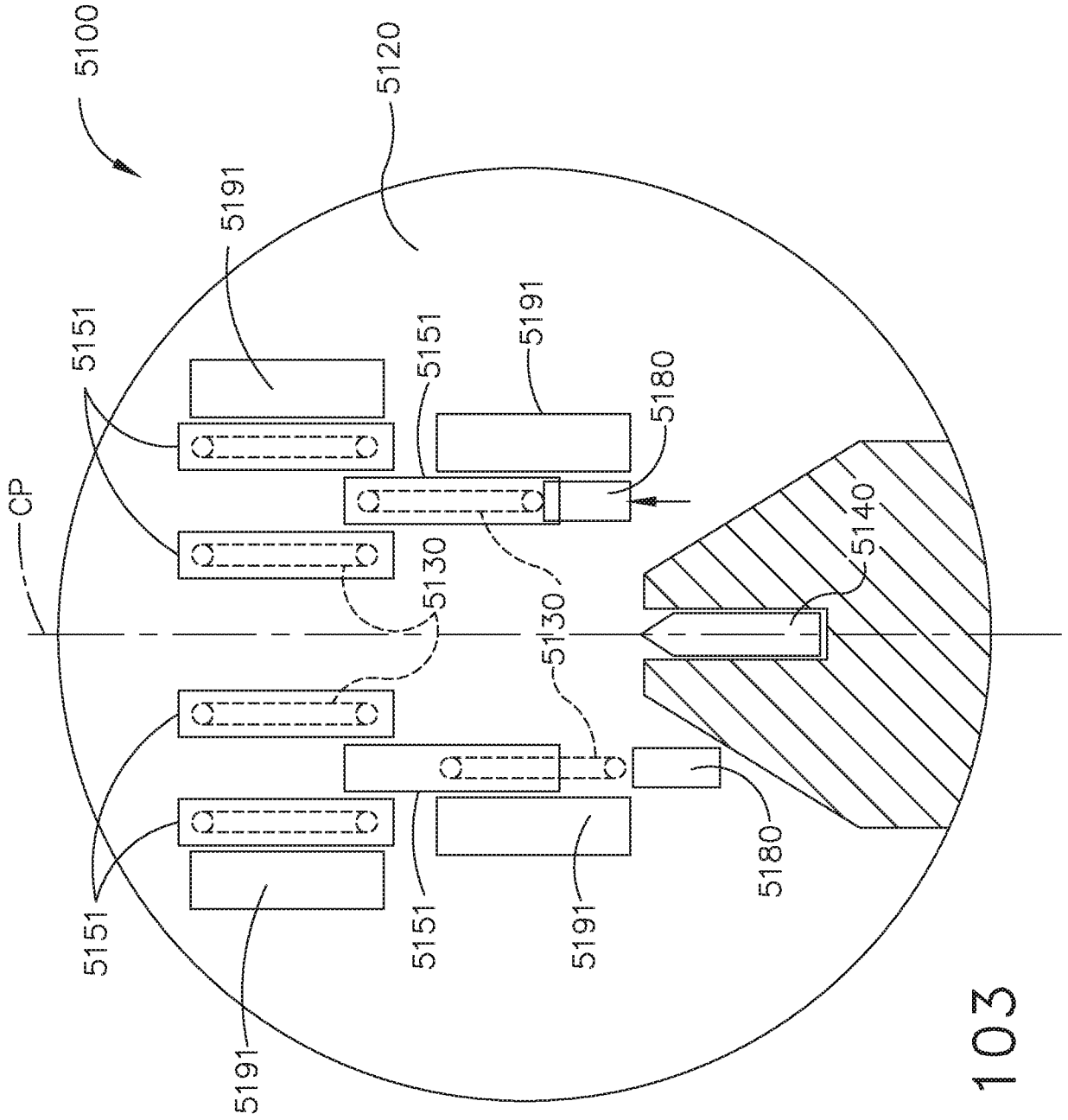

FIG. 103

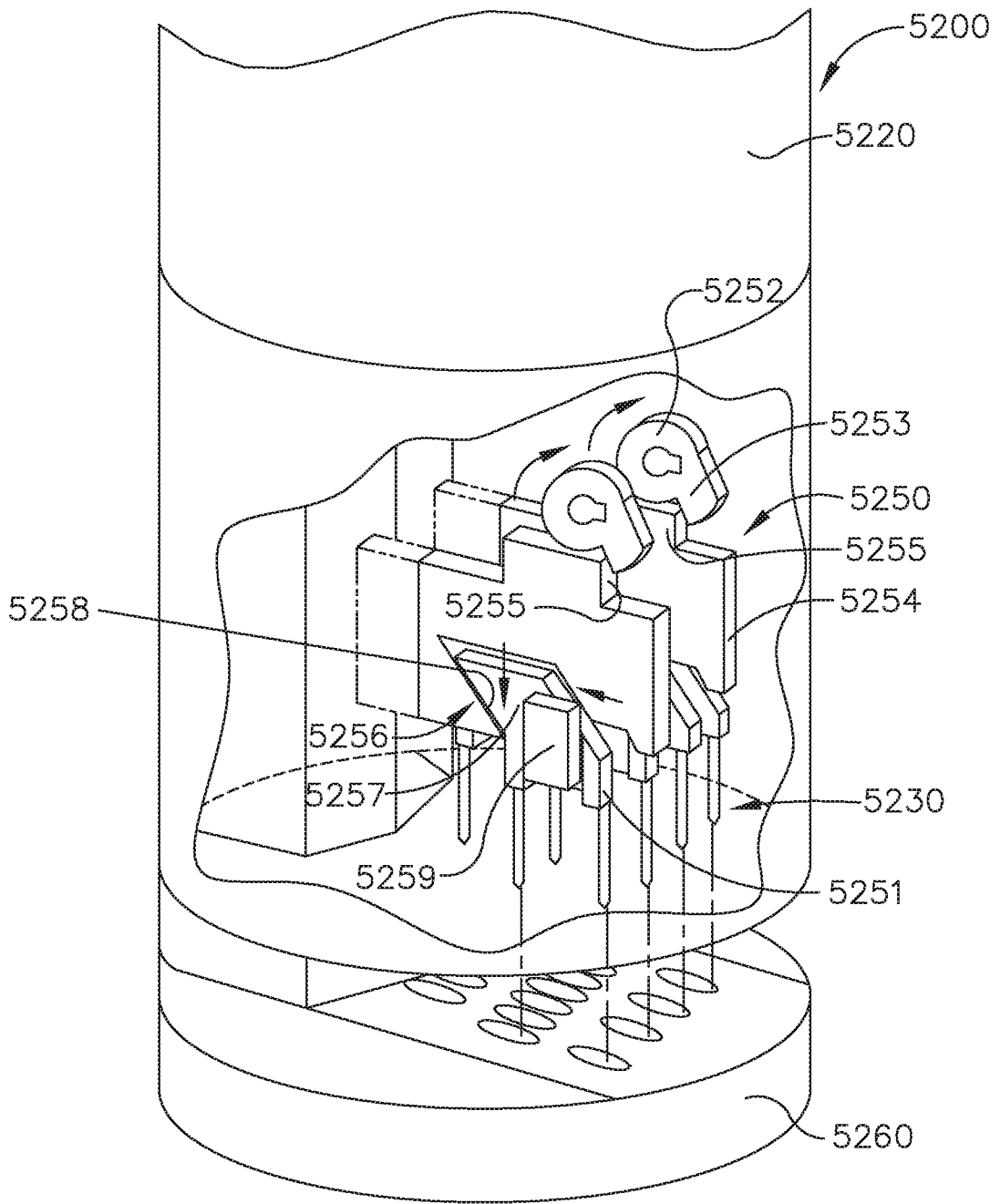

FIG. 104

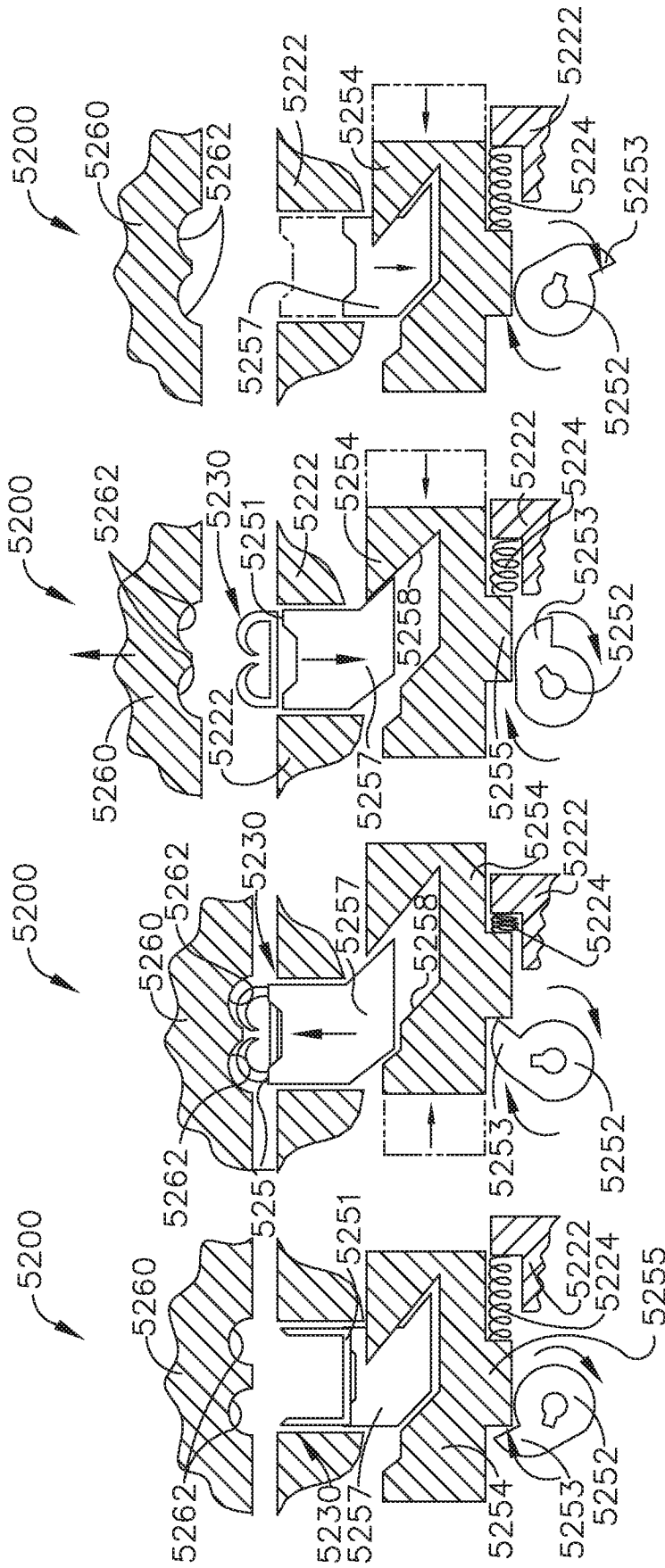

FIG. 105A FIG. 105B FIG. 105C FIG. 105D

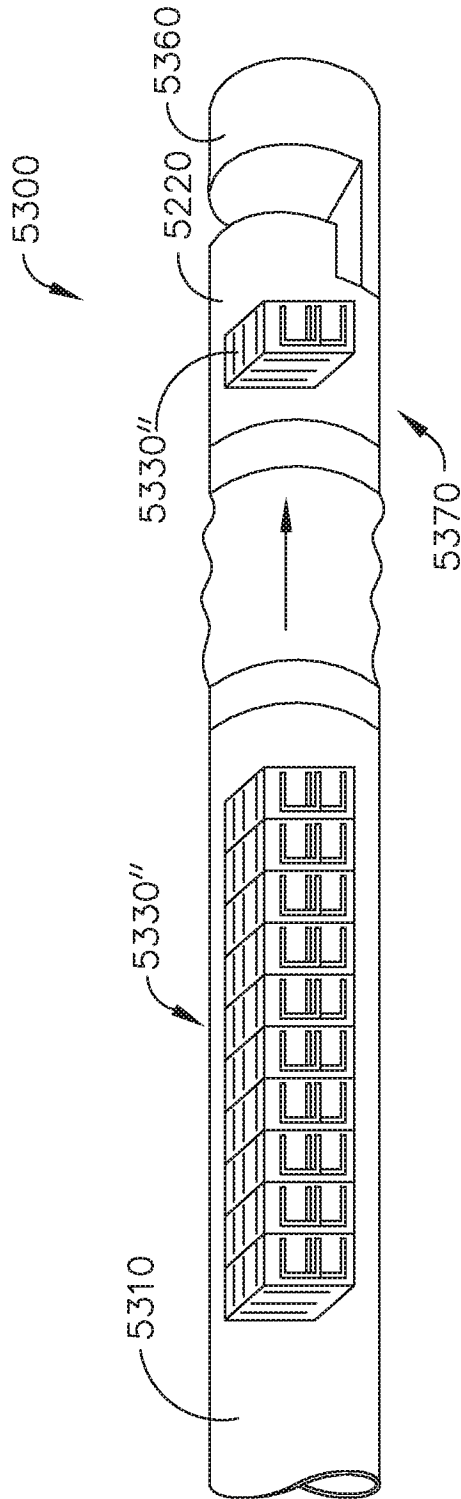

FIG. 106

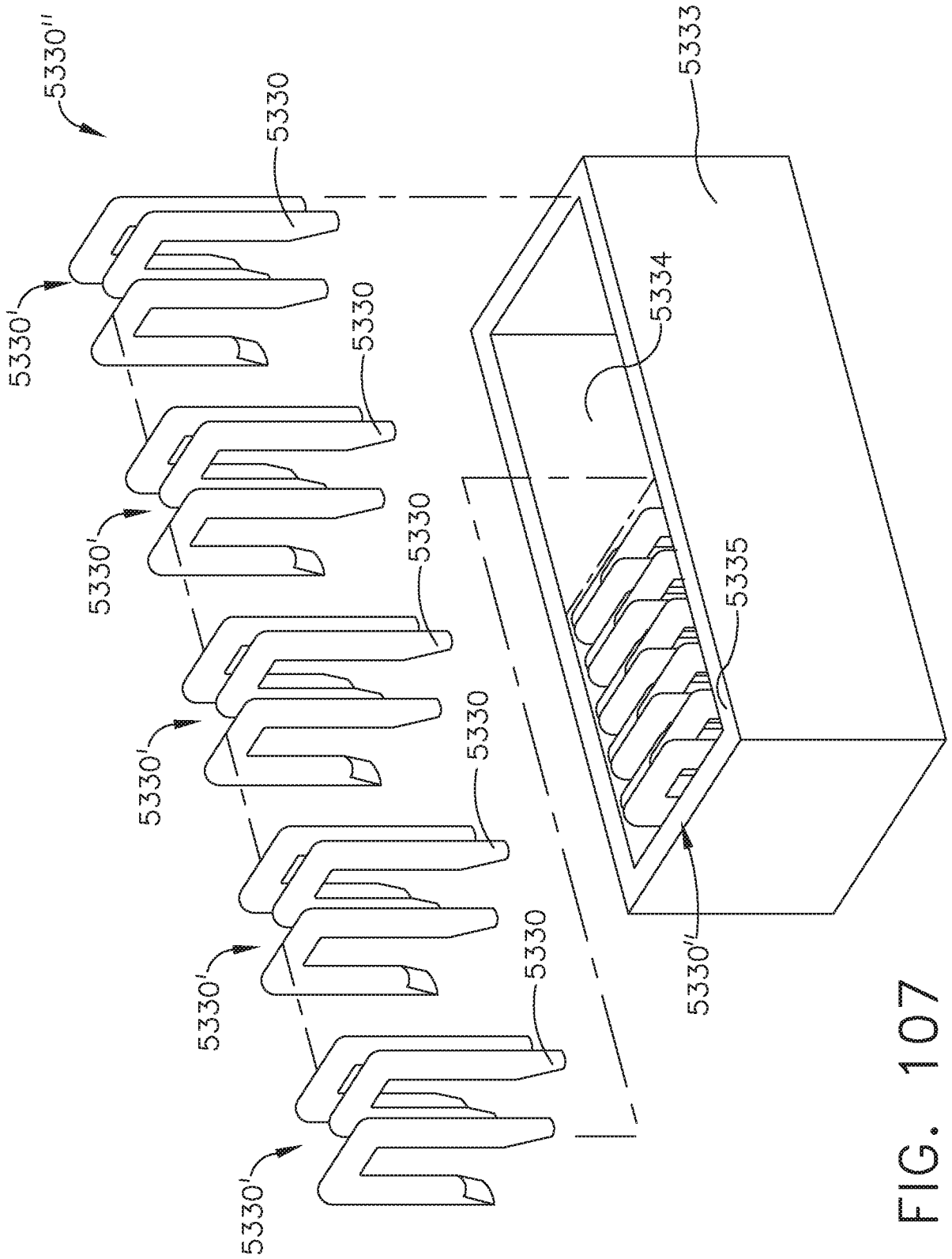

FIG. 107

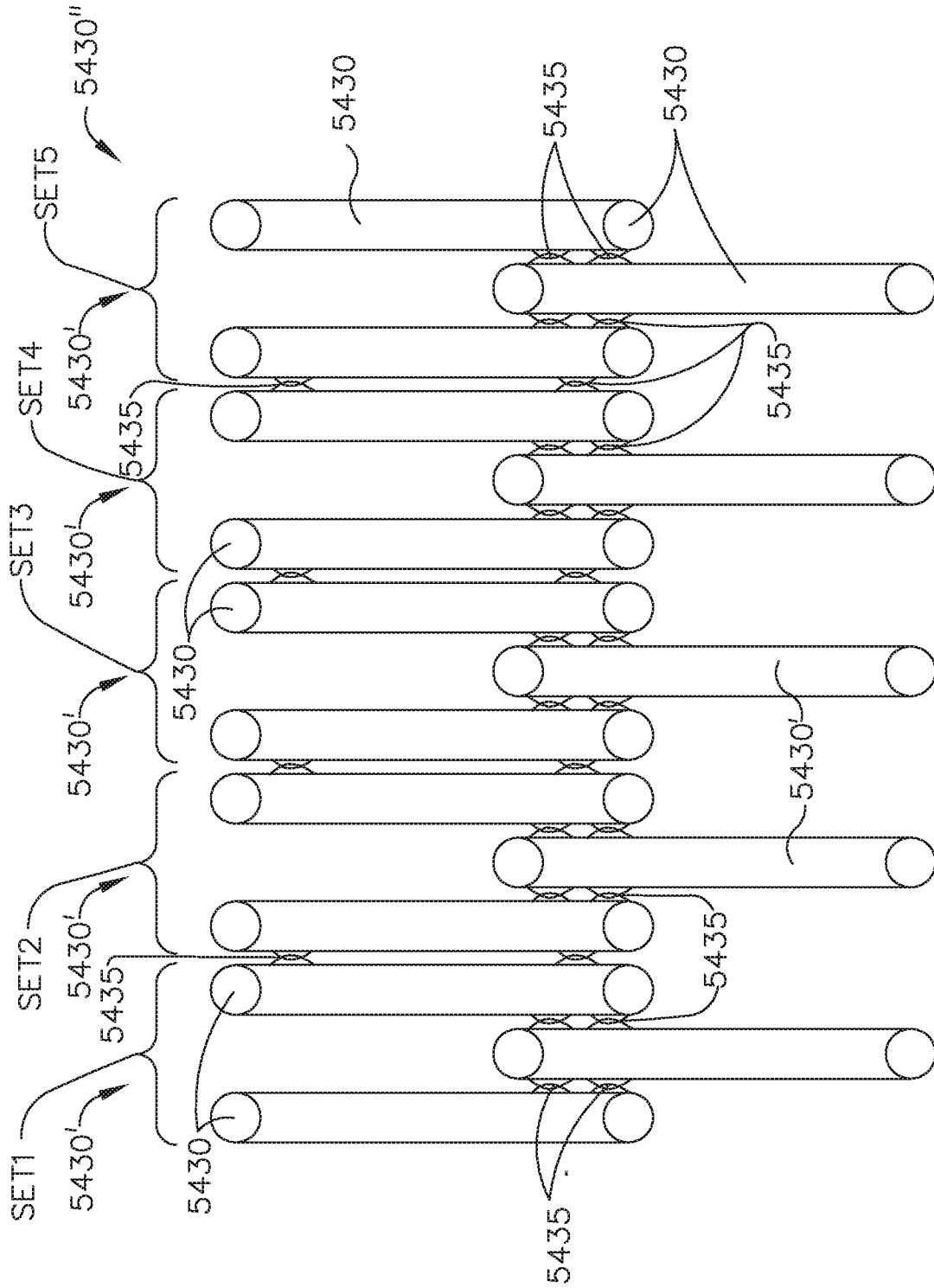

FIG. 108

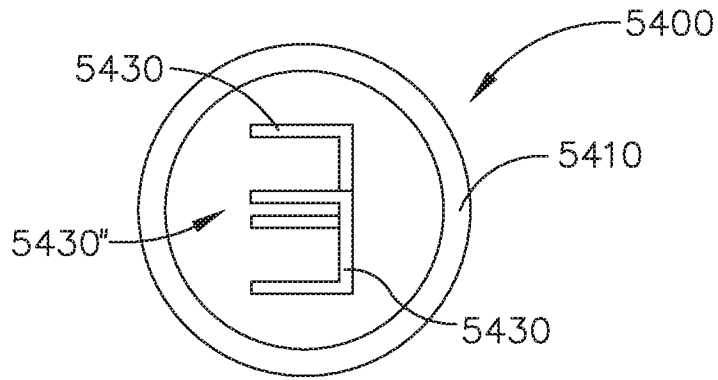
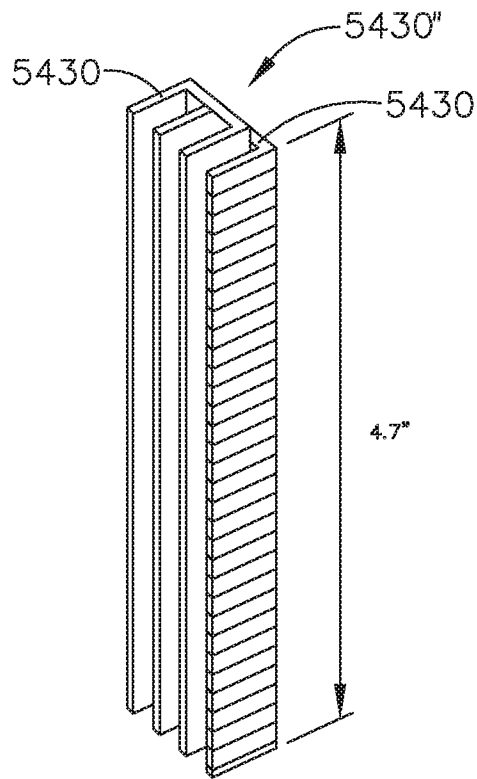

FIG. 109



total staples: 588

FIG. 110

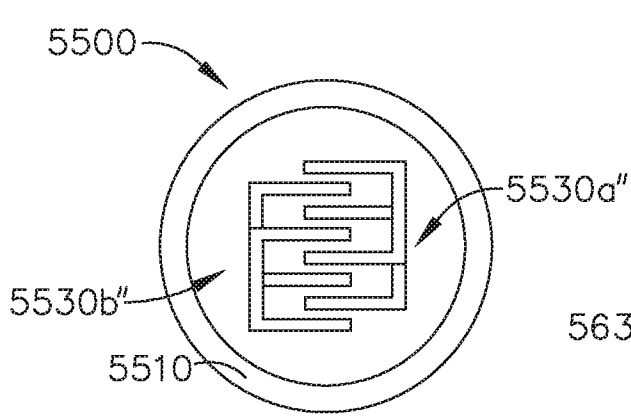

FIG. 111

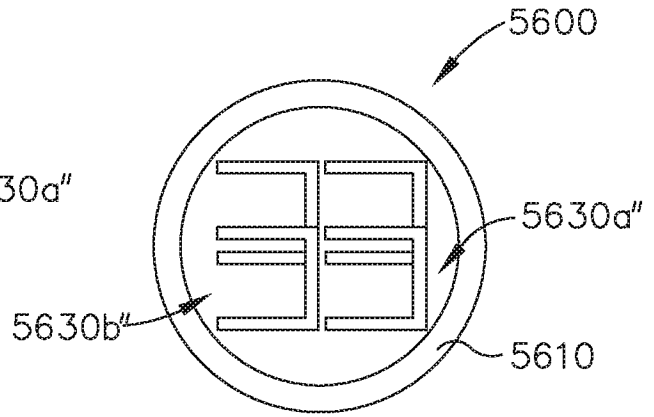
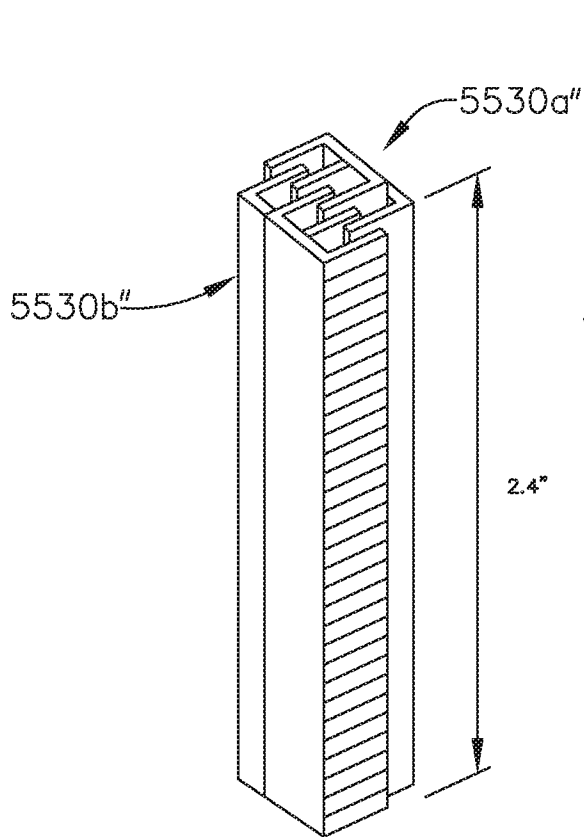
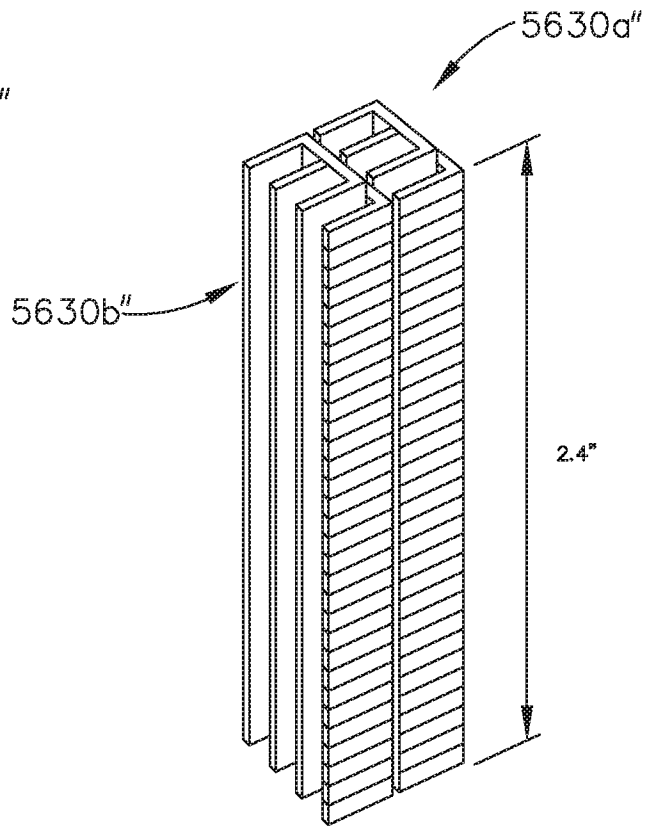

FIG. 113



total staples: 588

FIG. 112



total staples: 588

FIG. 114

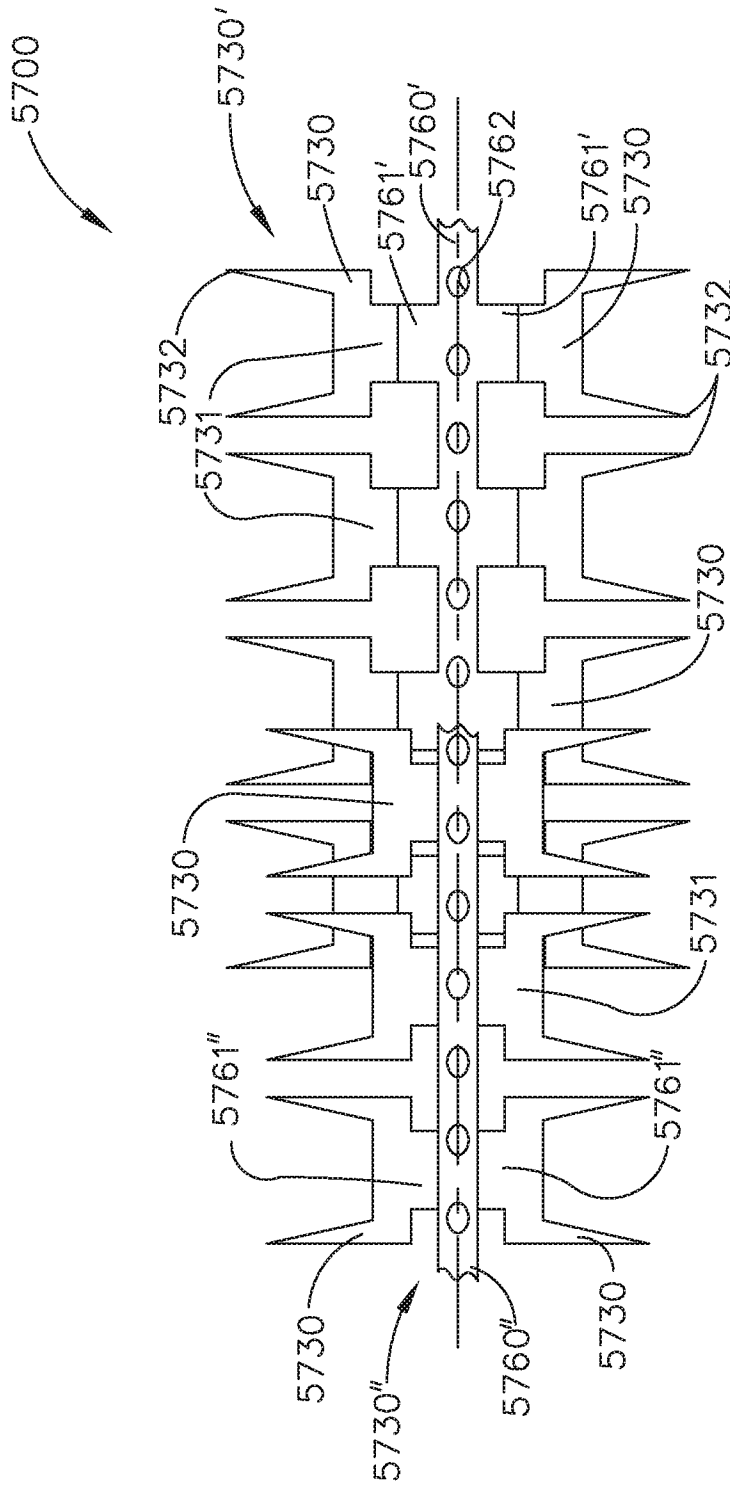

FIG. 115

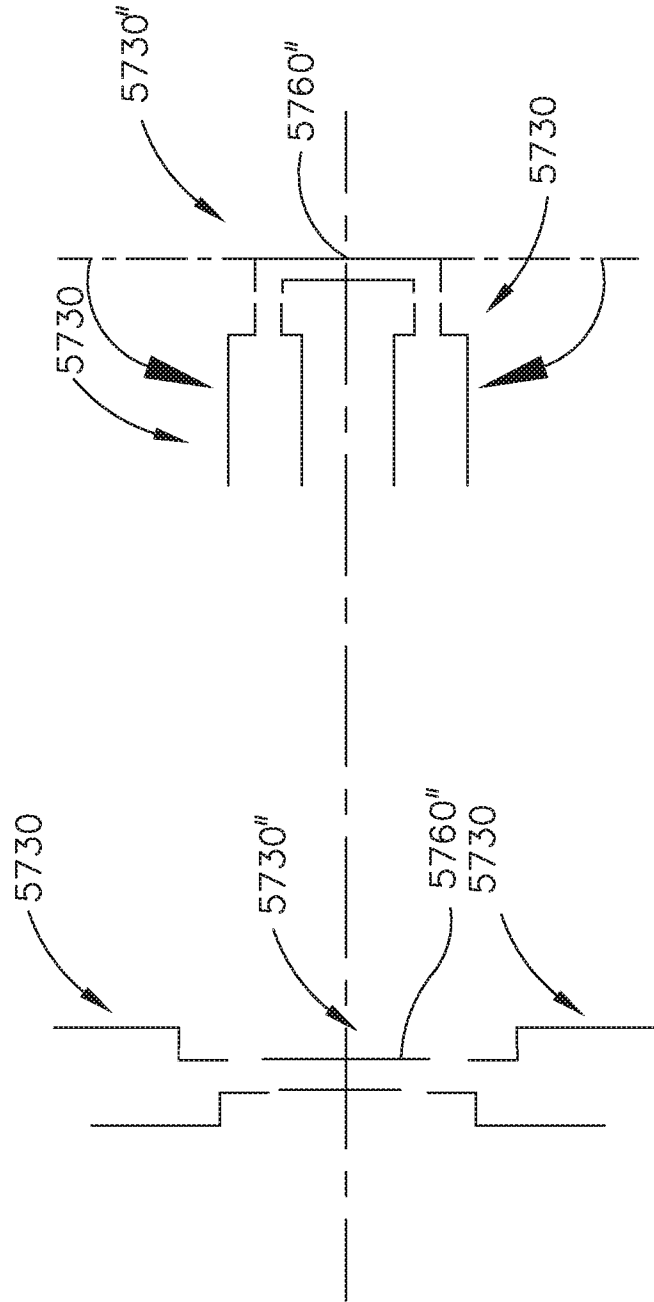

FIG. 116

FIG. 117

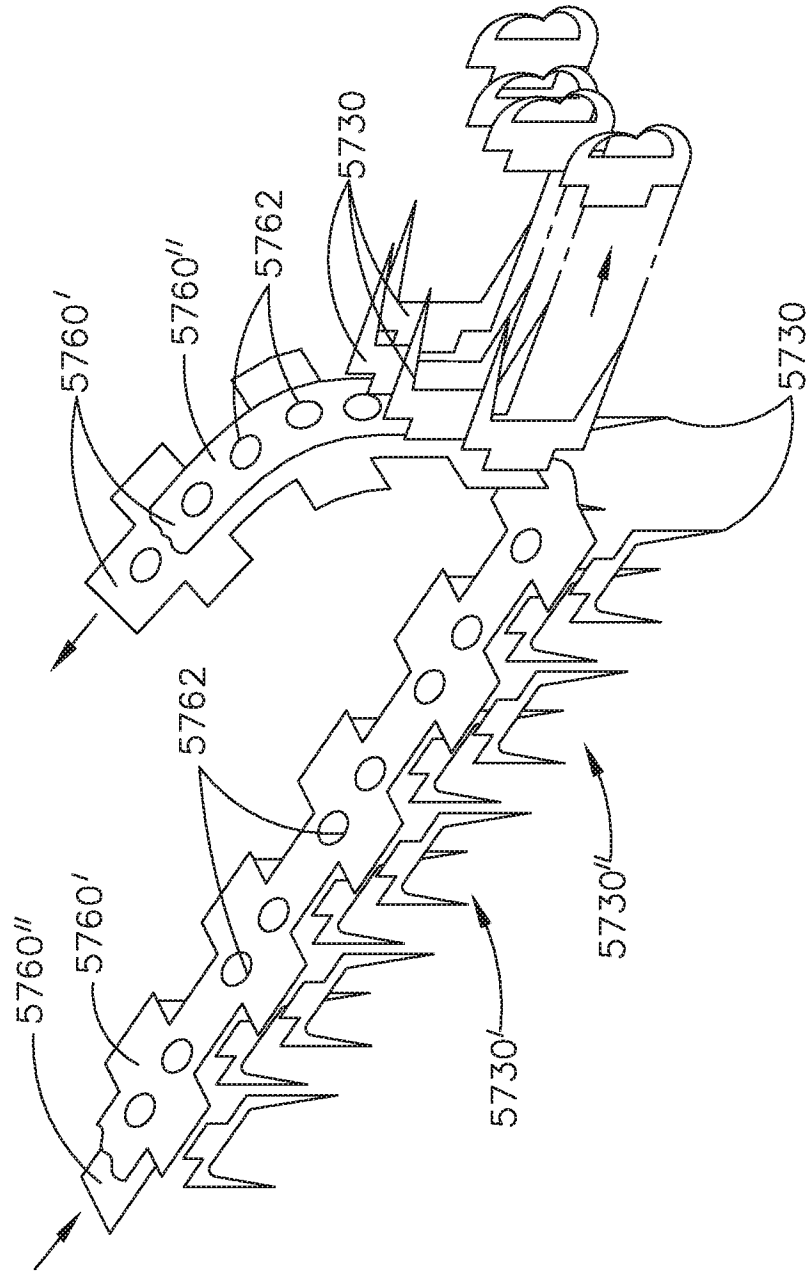

FIG. 118

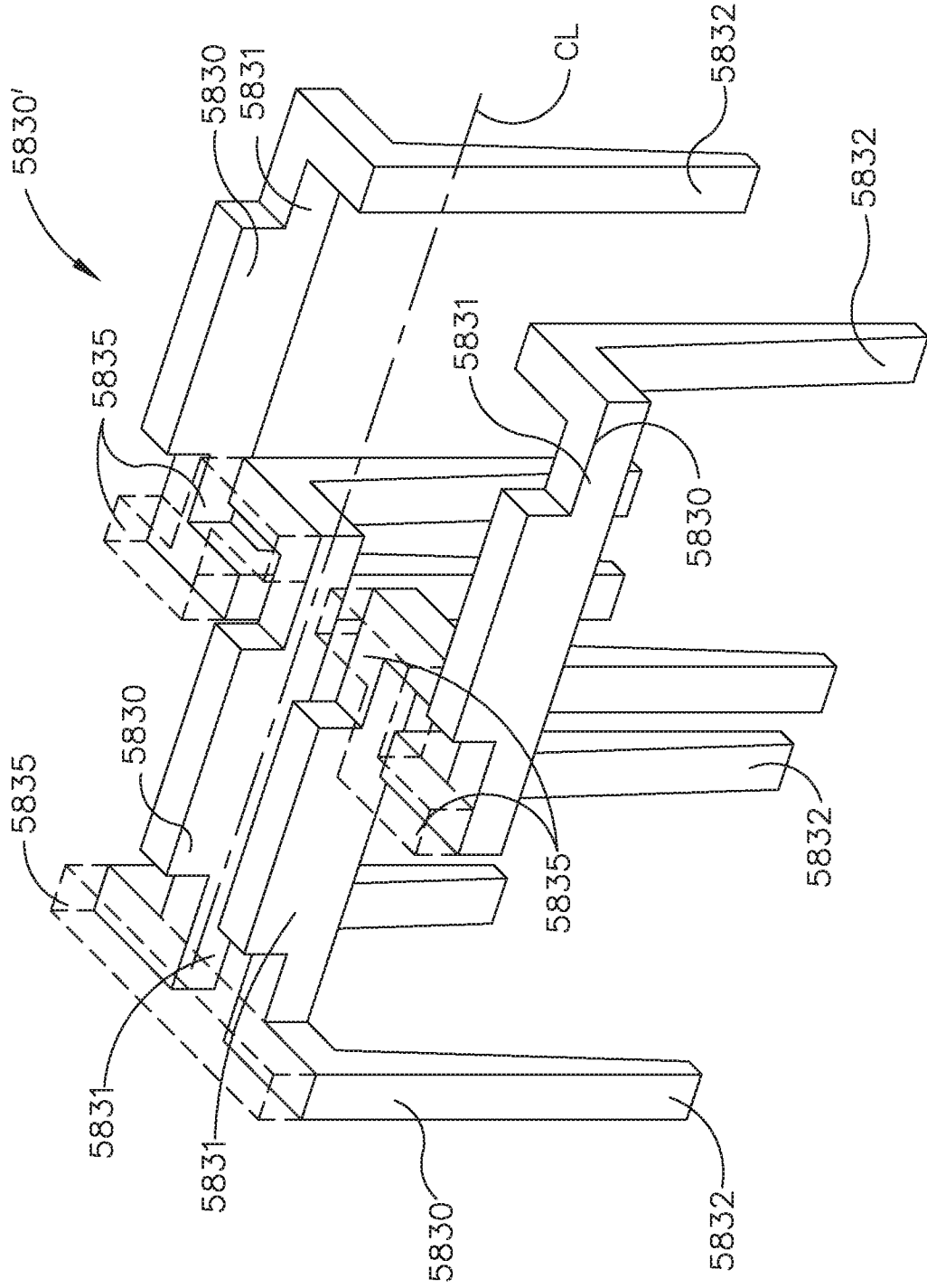

FIG. 119

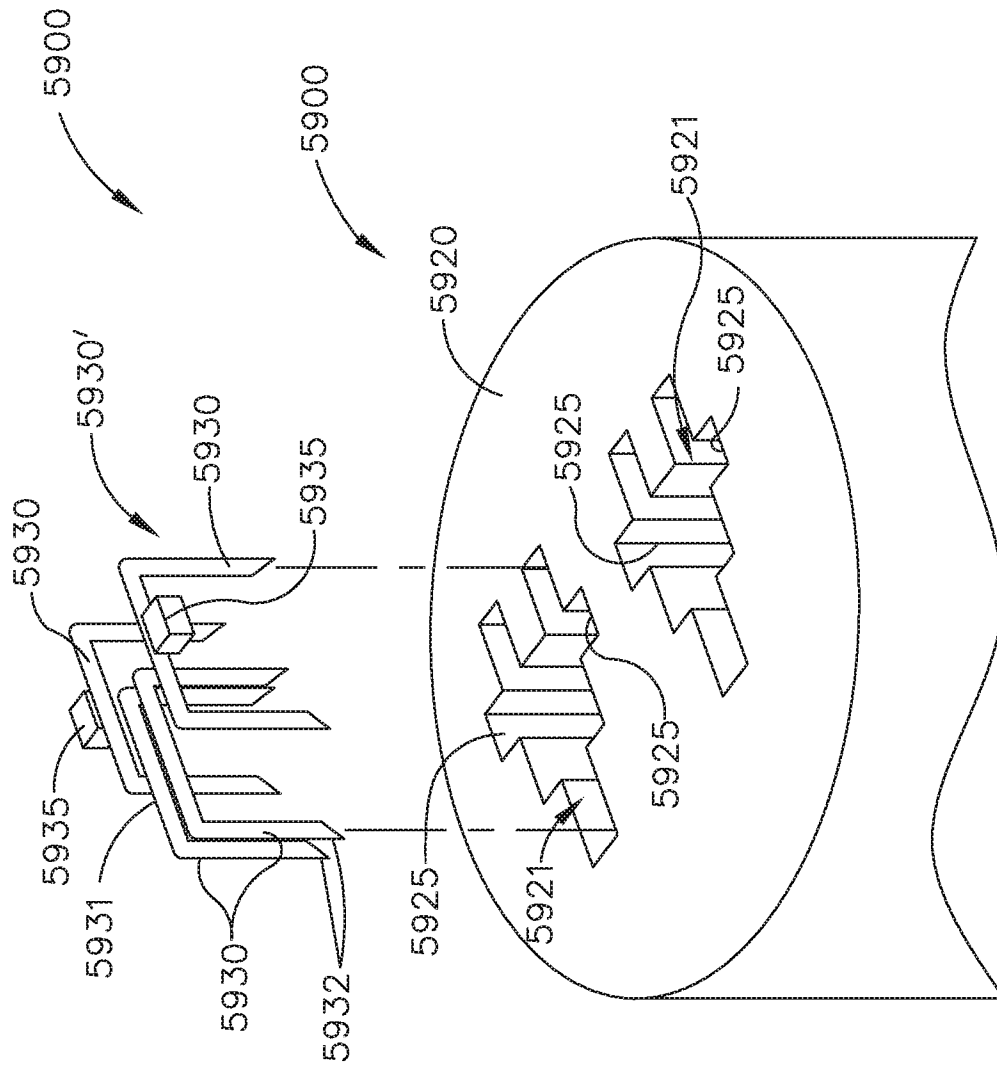

FIG. 120

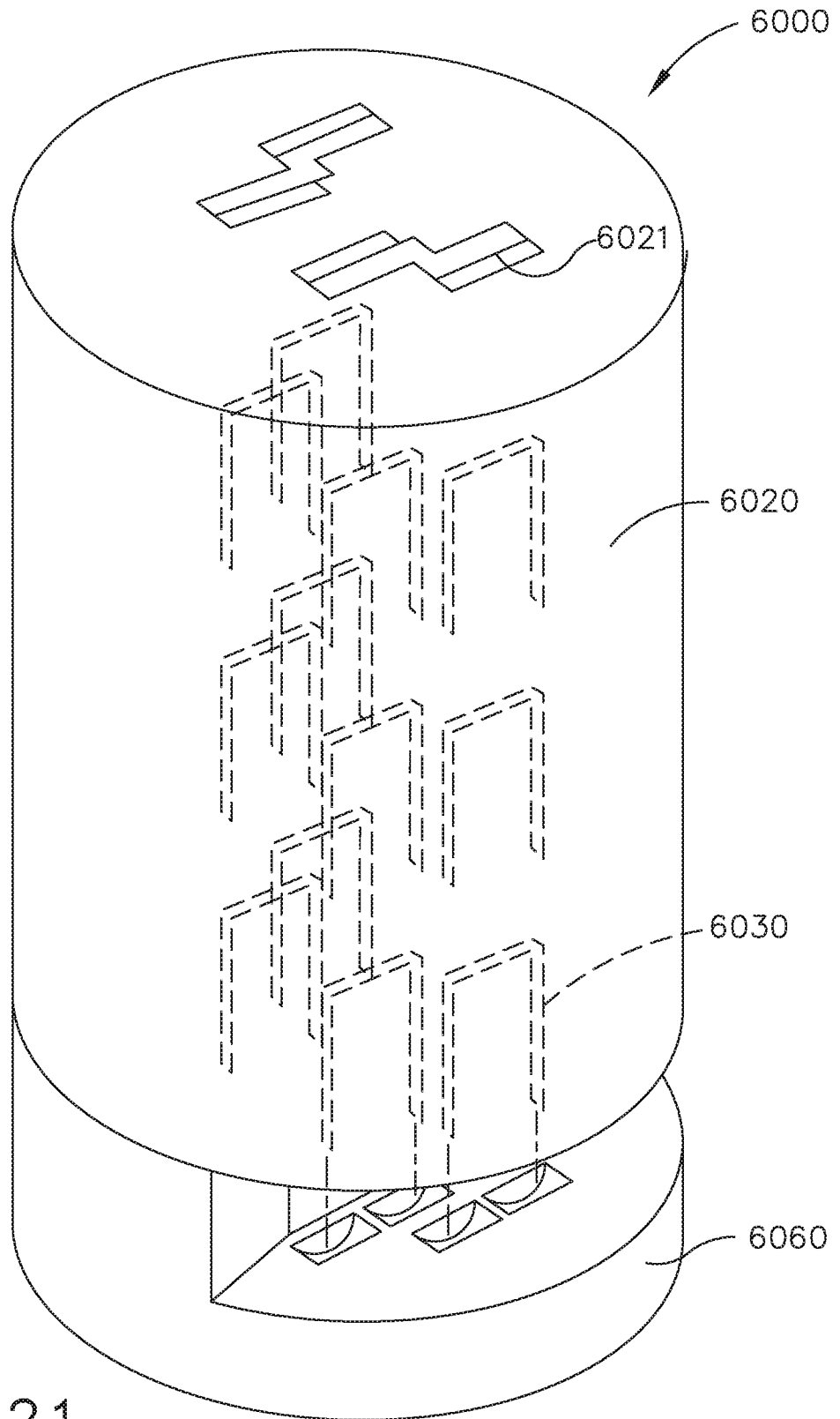

FIG. 121

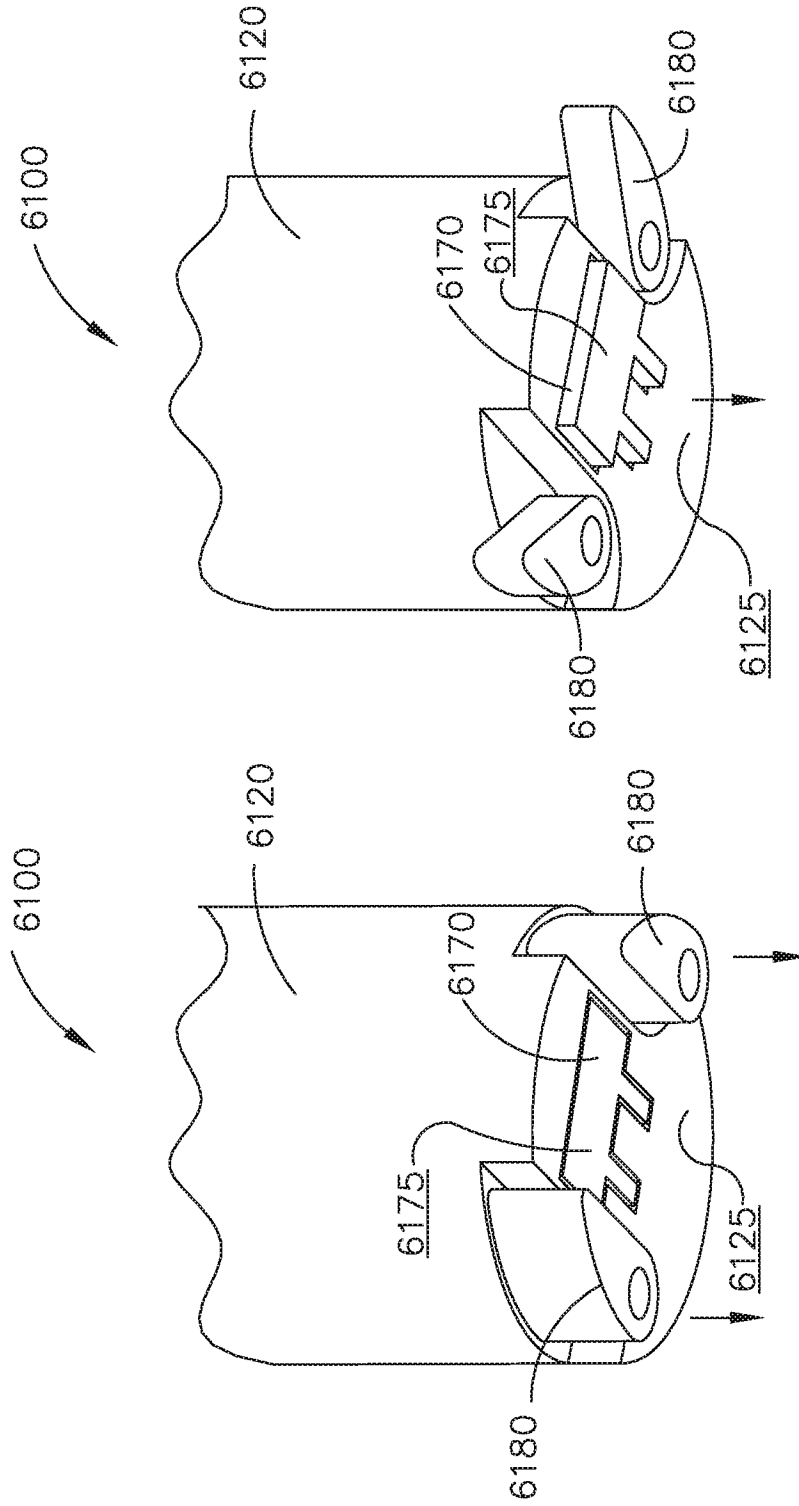

FIG. 123

FIG. 122

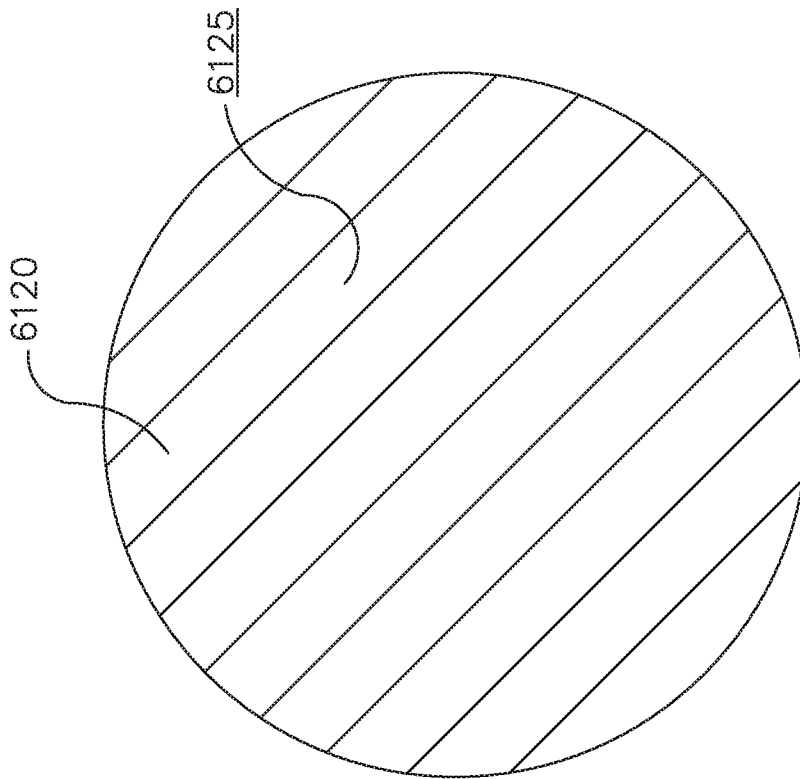

FIG. 124

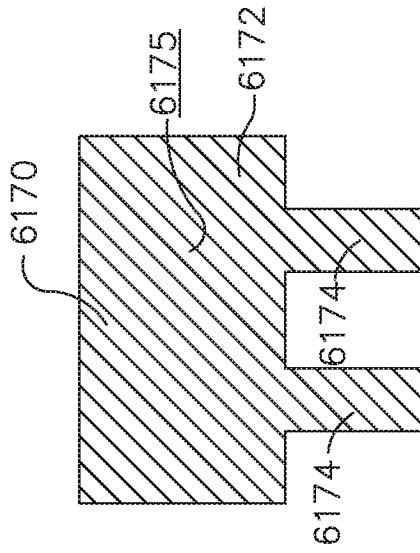

FIG. 125

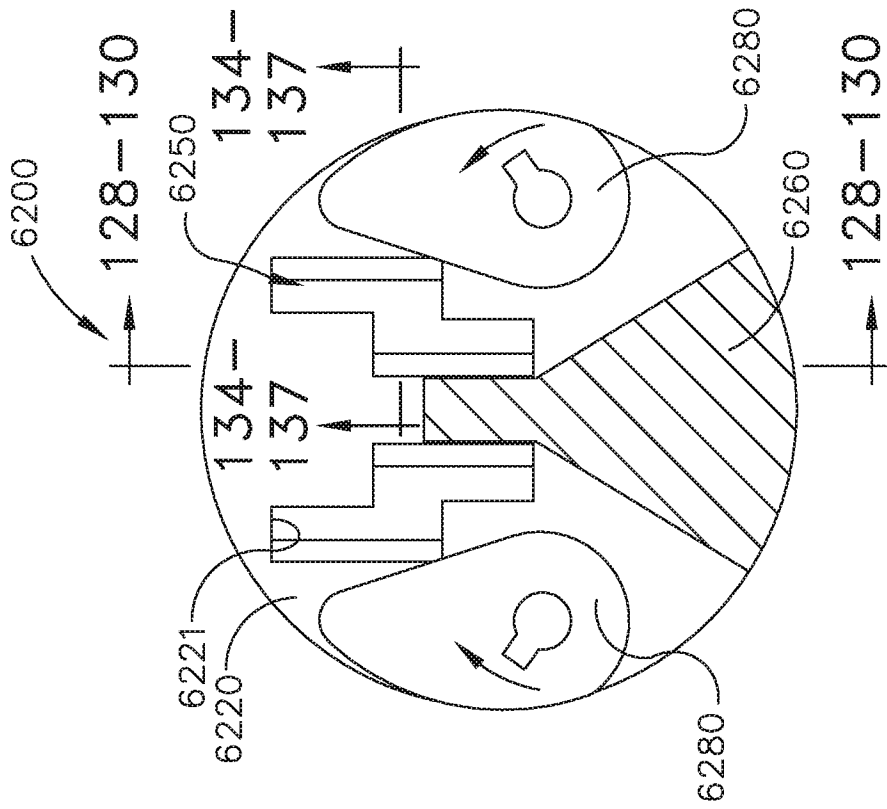

FIG. 126

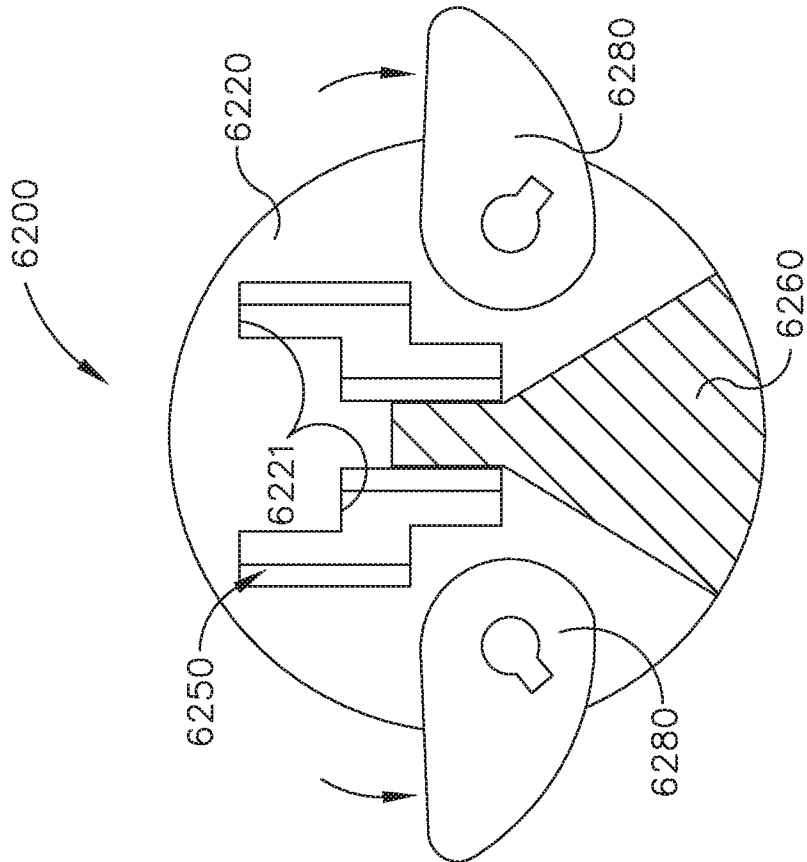

FIG. 127

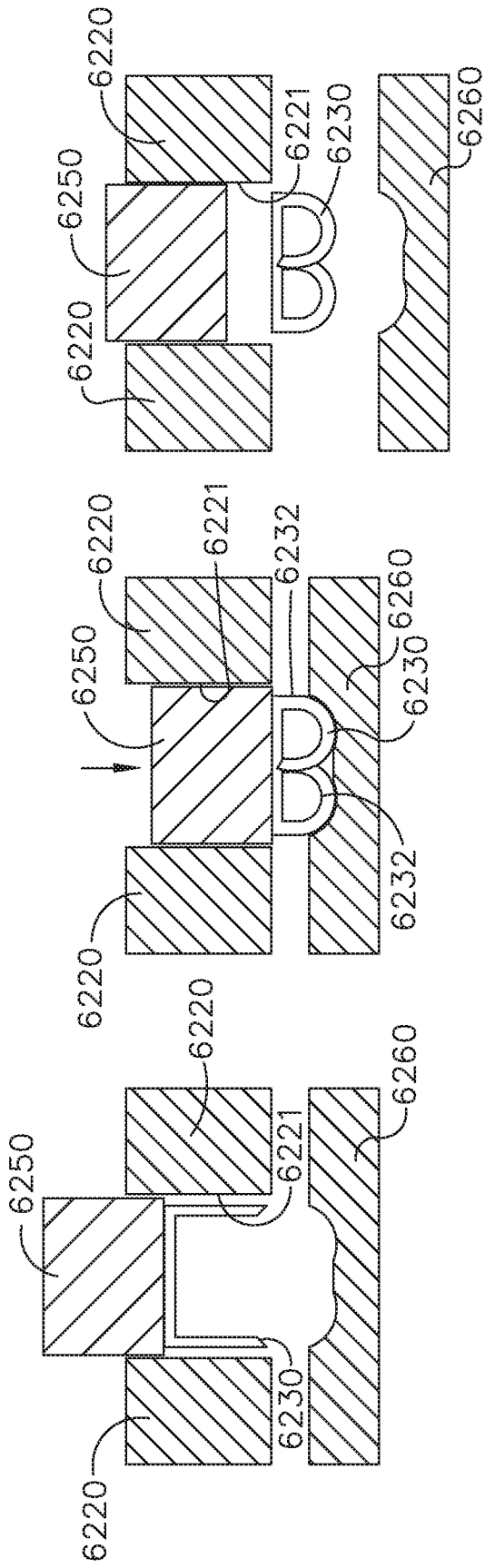

FIG. 128

FIG. 129

FIG. 130

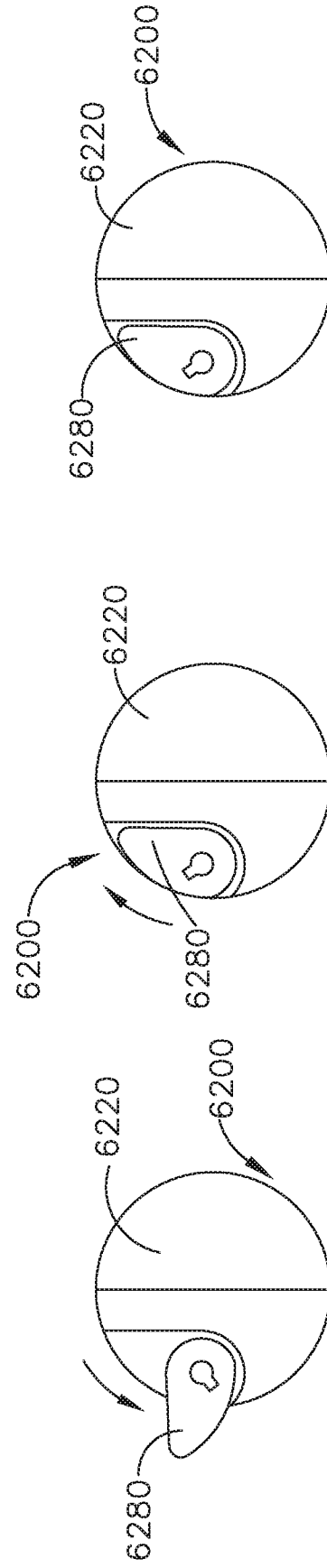

FIG. 128A

FIG. 129A

FIG. 130A

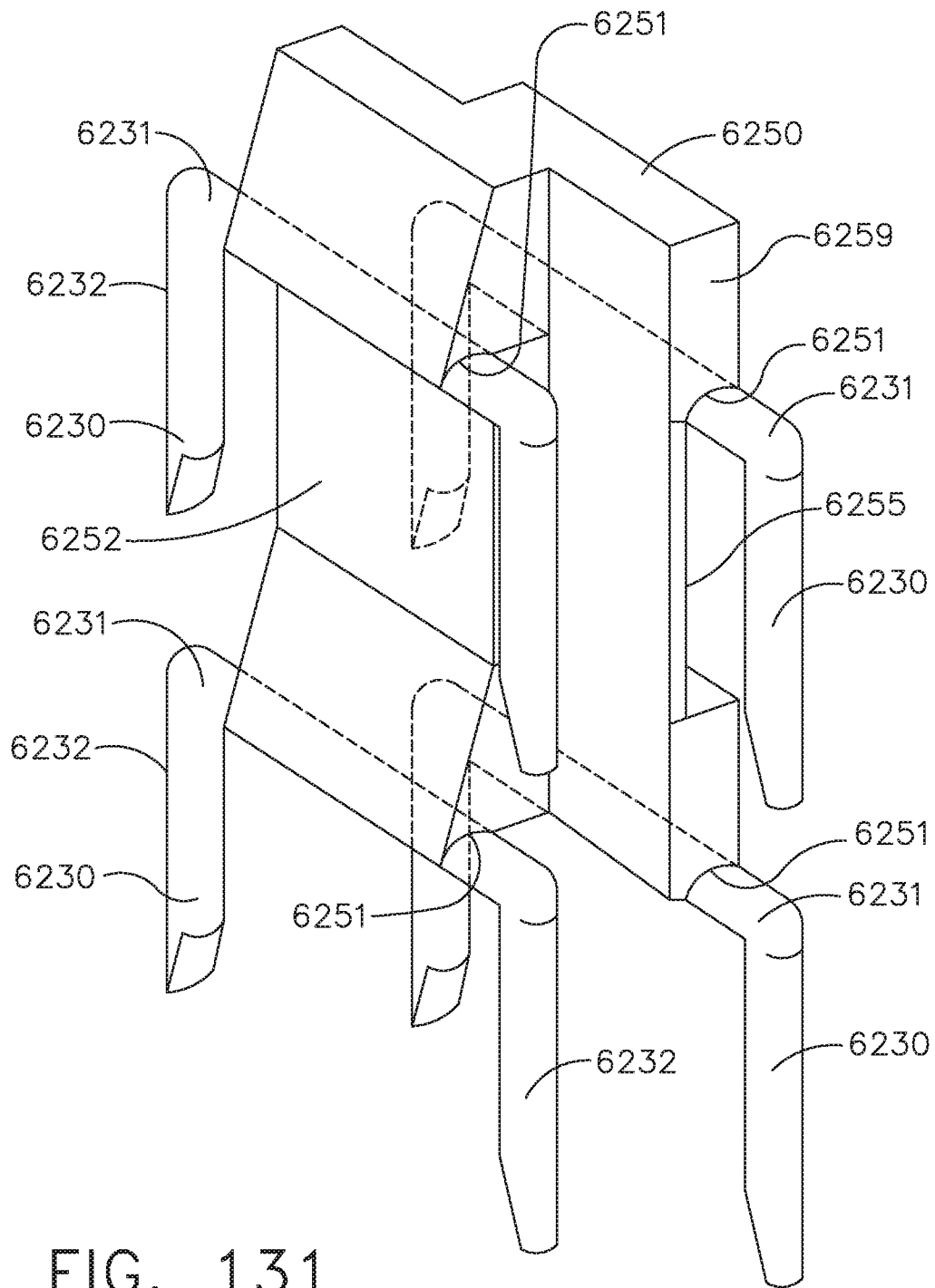

FIG. 131

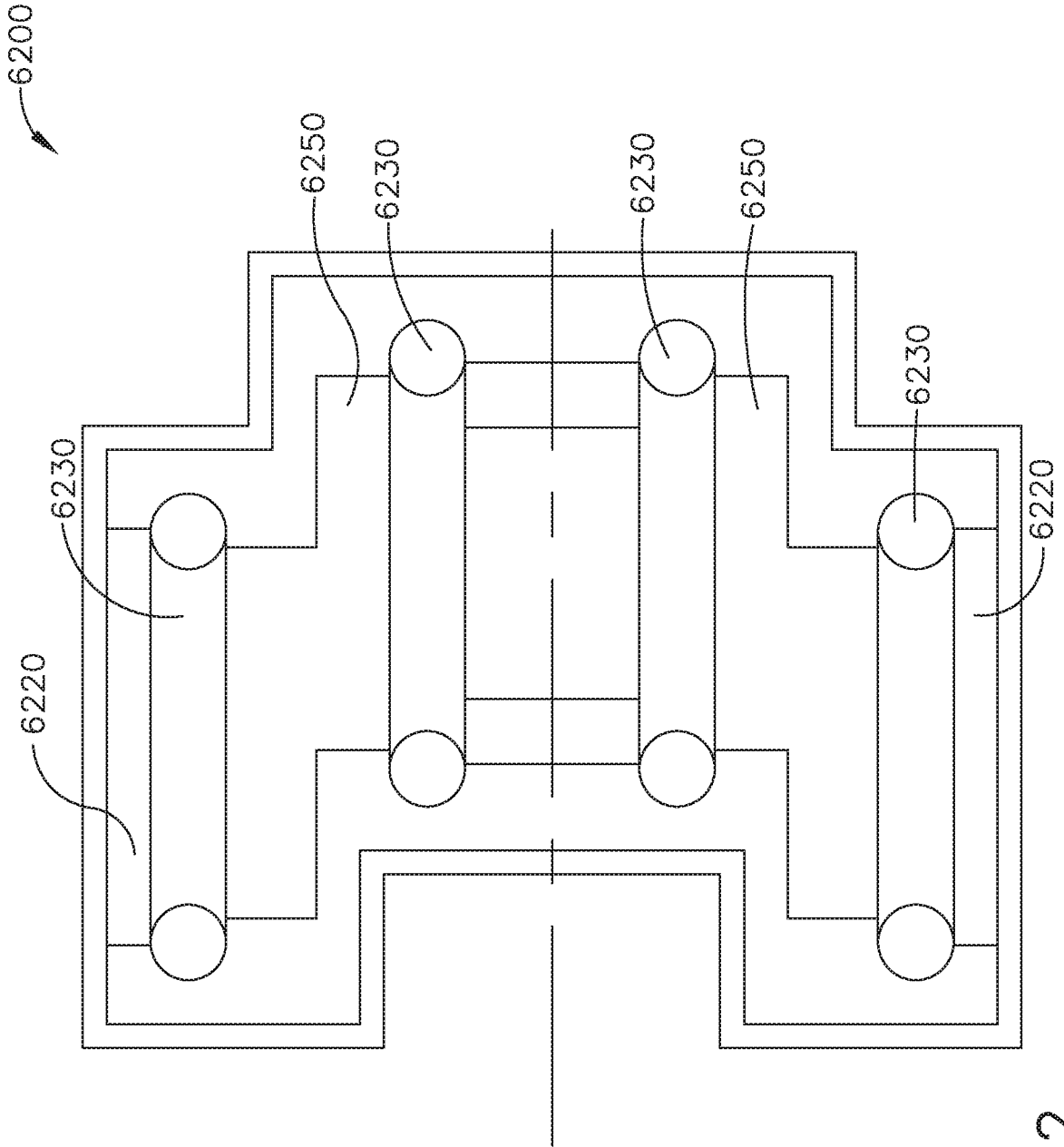

FIG. 132

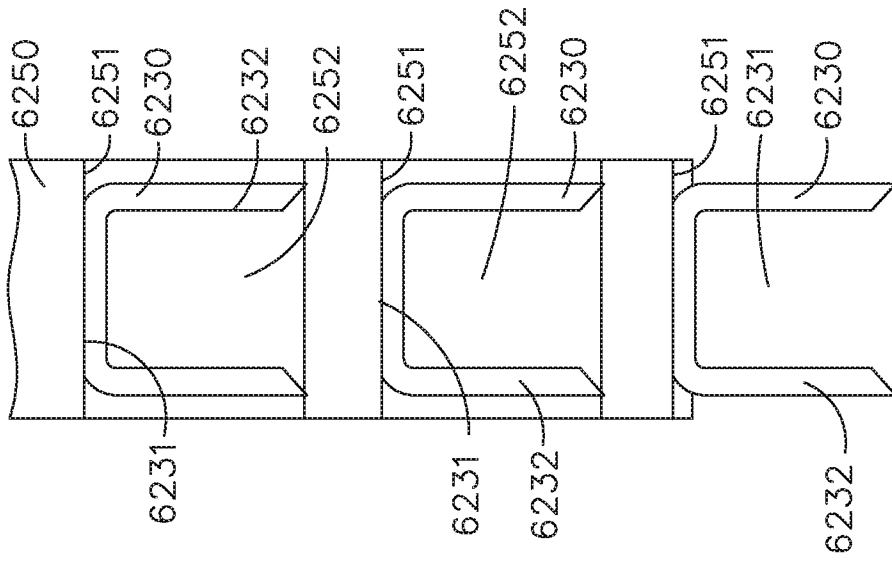

FIG. 133

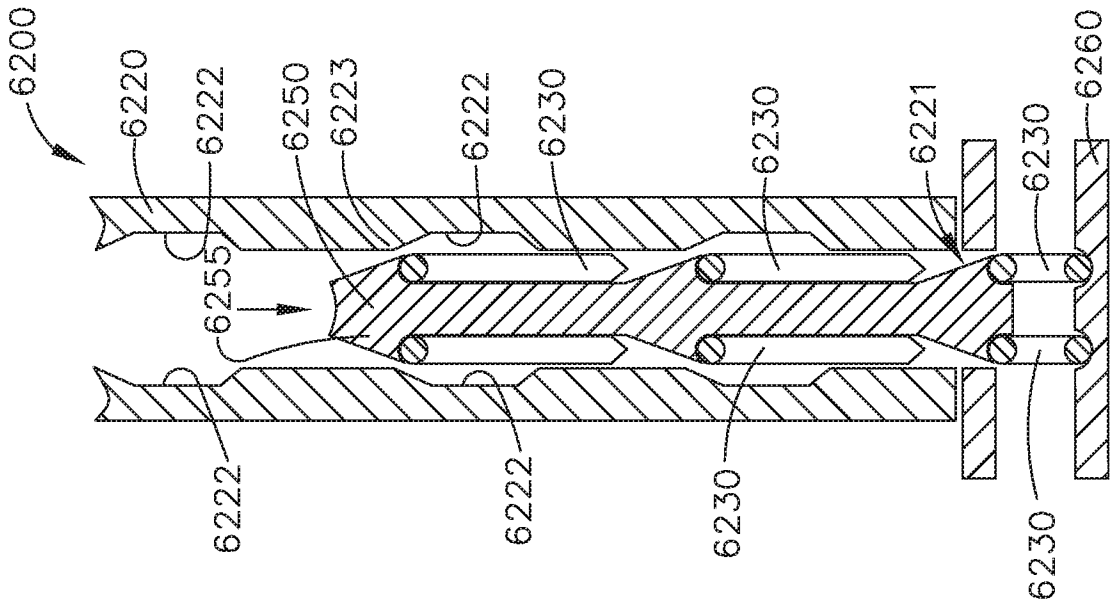

FIG. 135

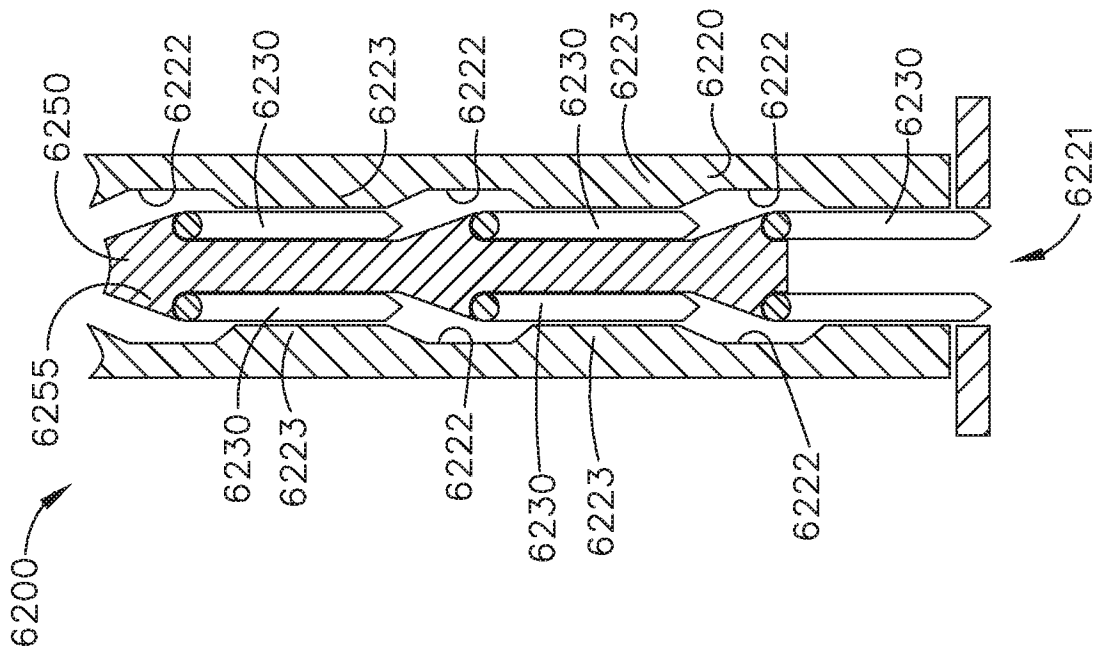

FIG. 134

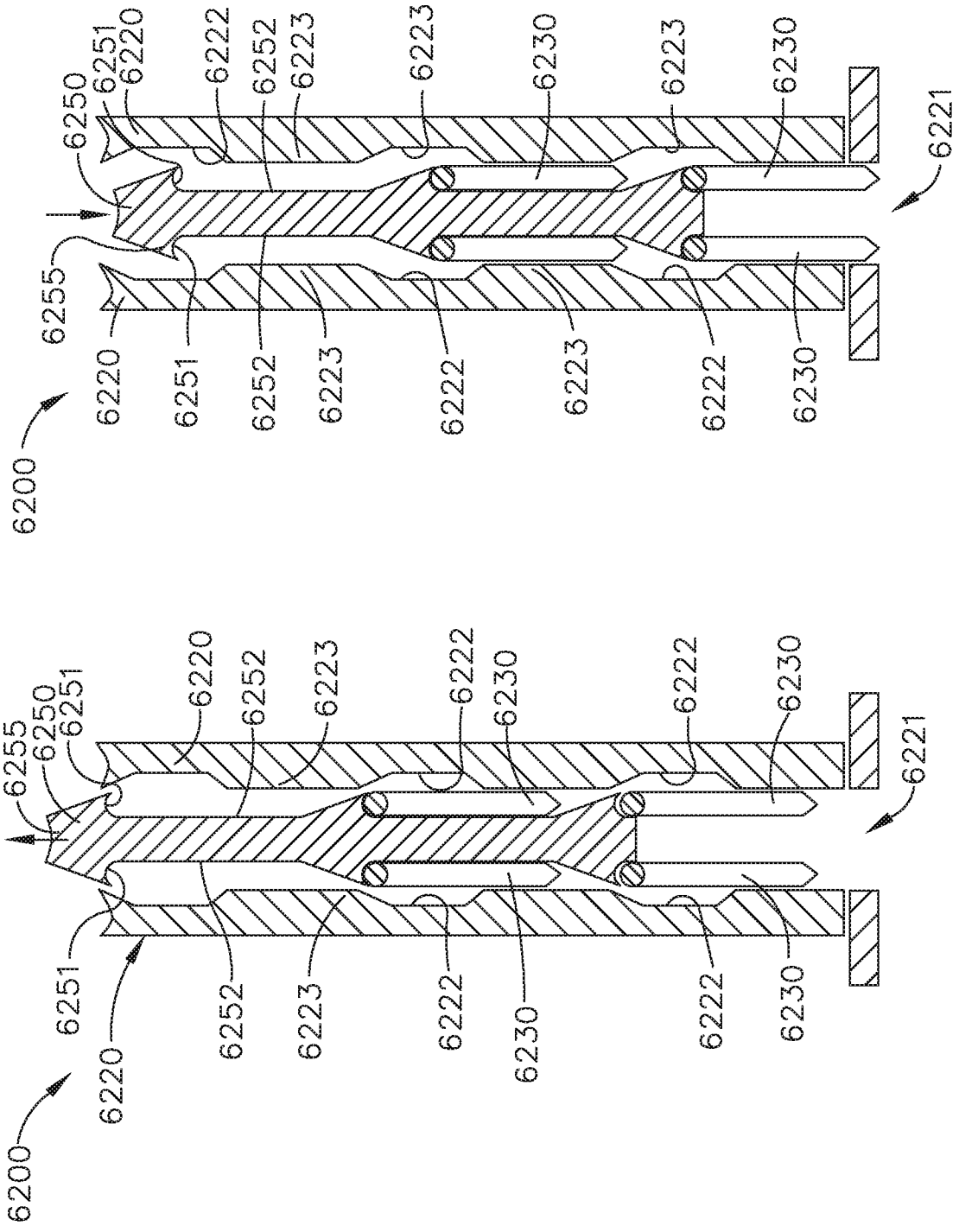

FIG. 137

FIG. 136

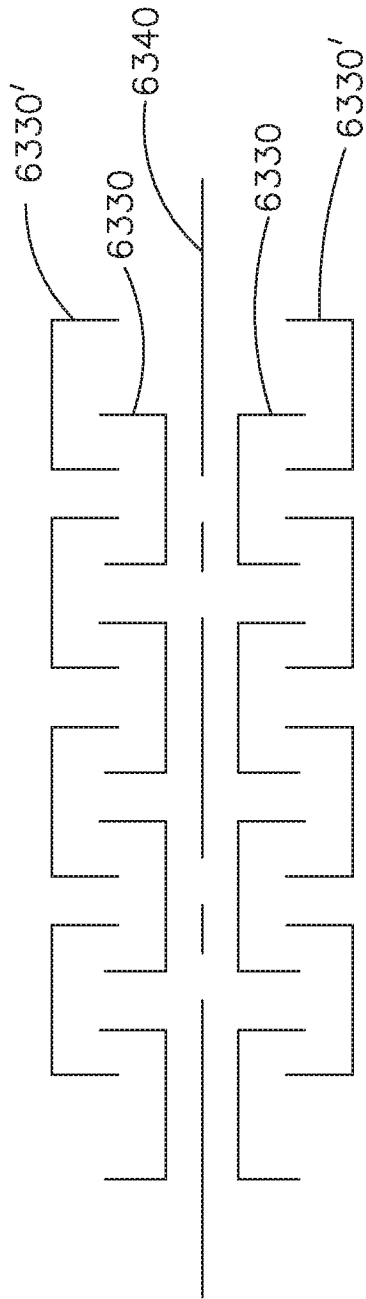

FIG. 138

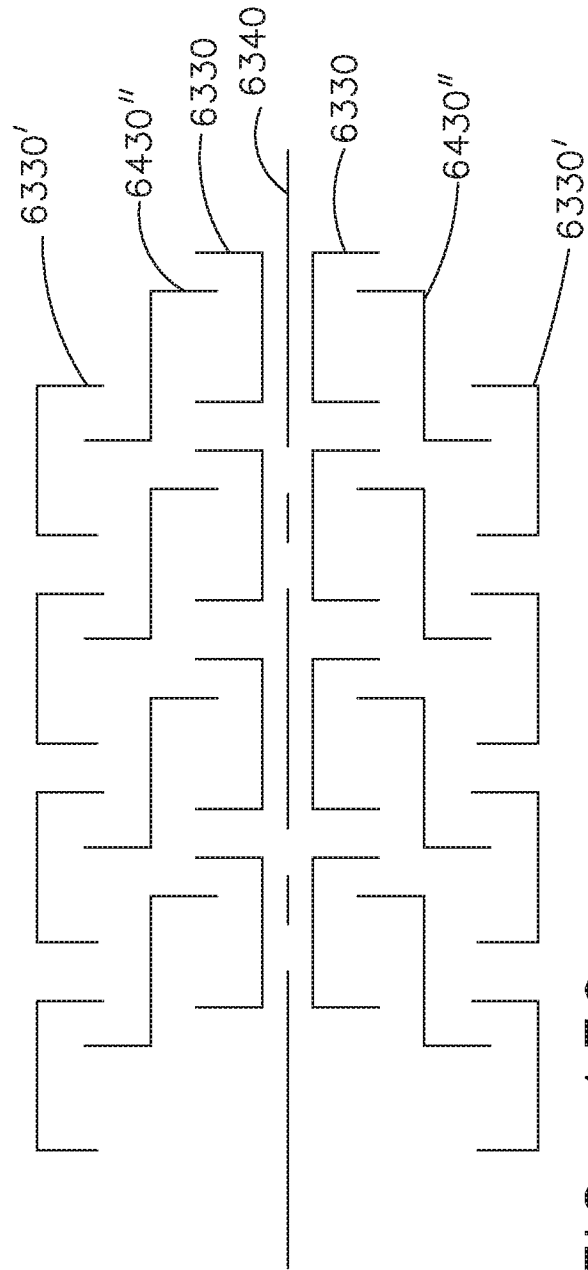

FIG. 139

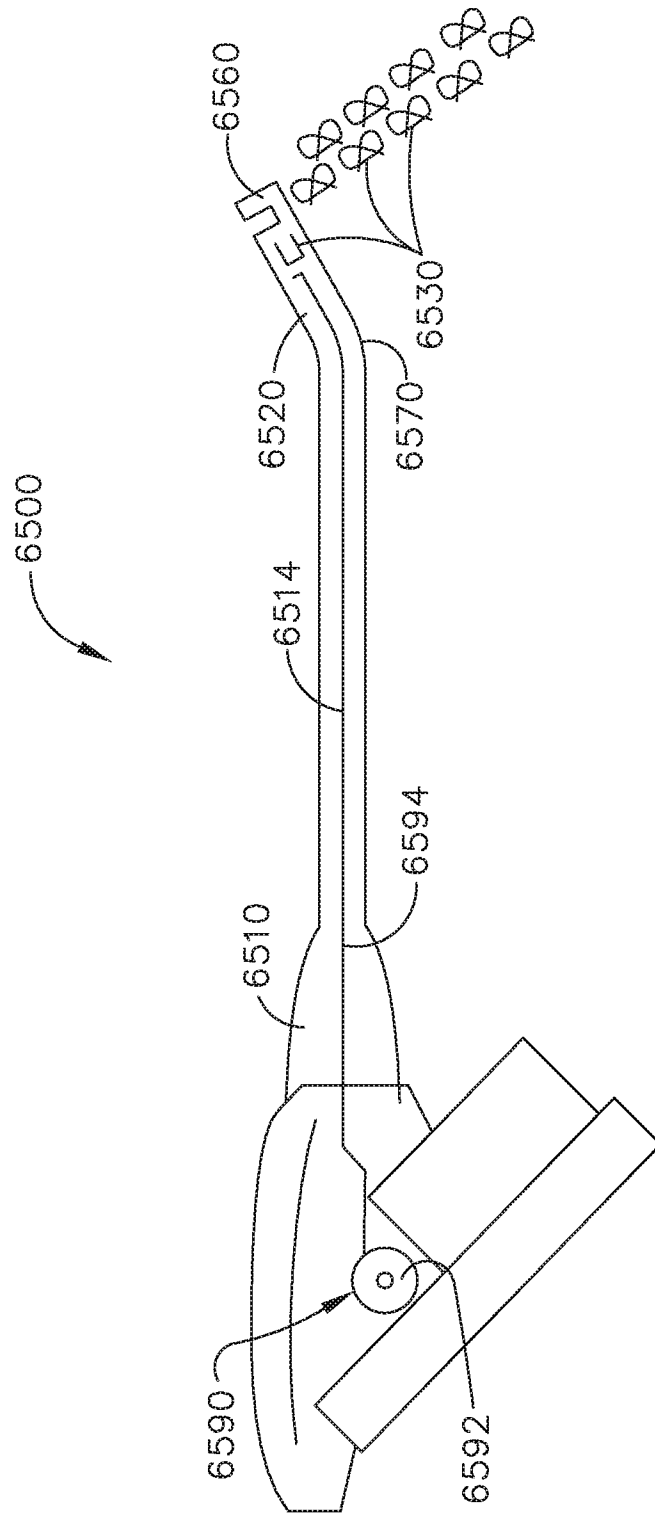

FIG. 140

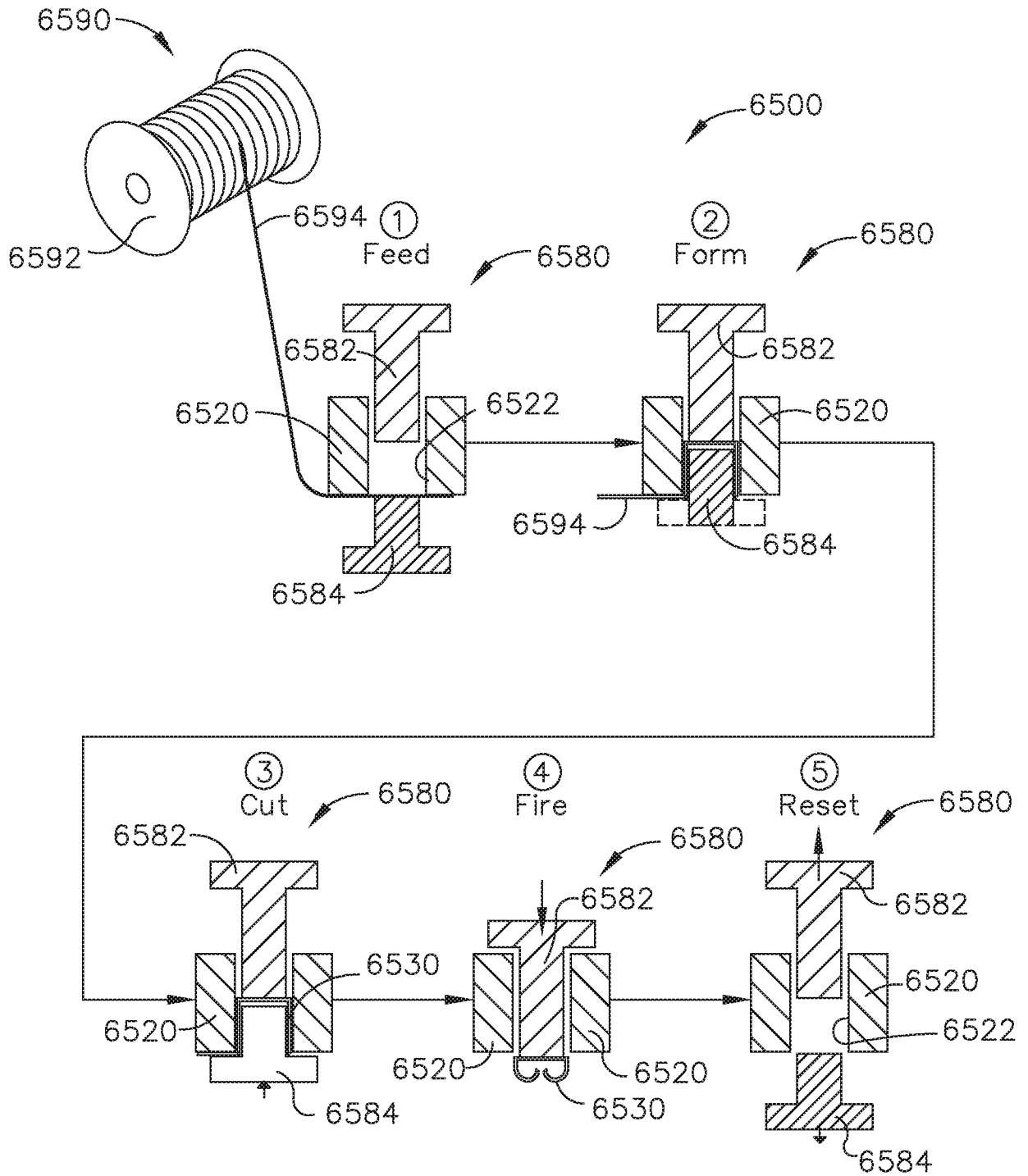

FIG. 141

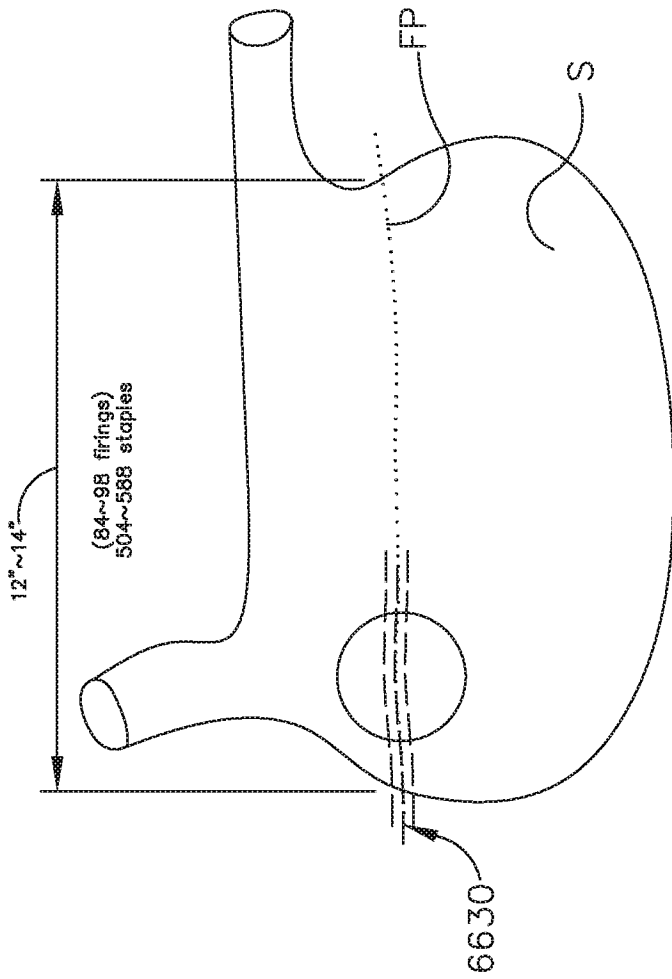

FIG. 142

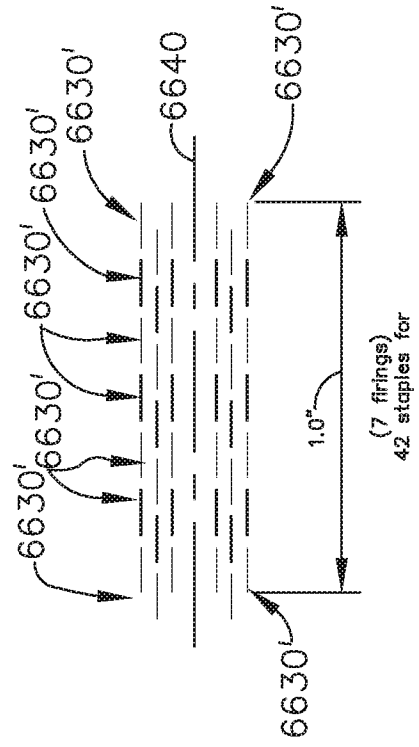

FIG. 143

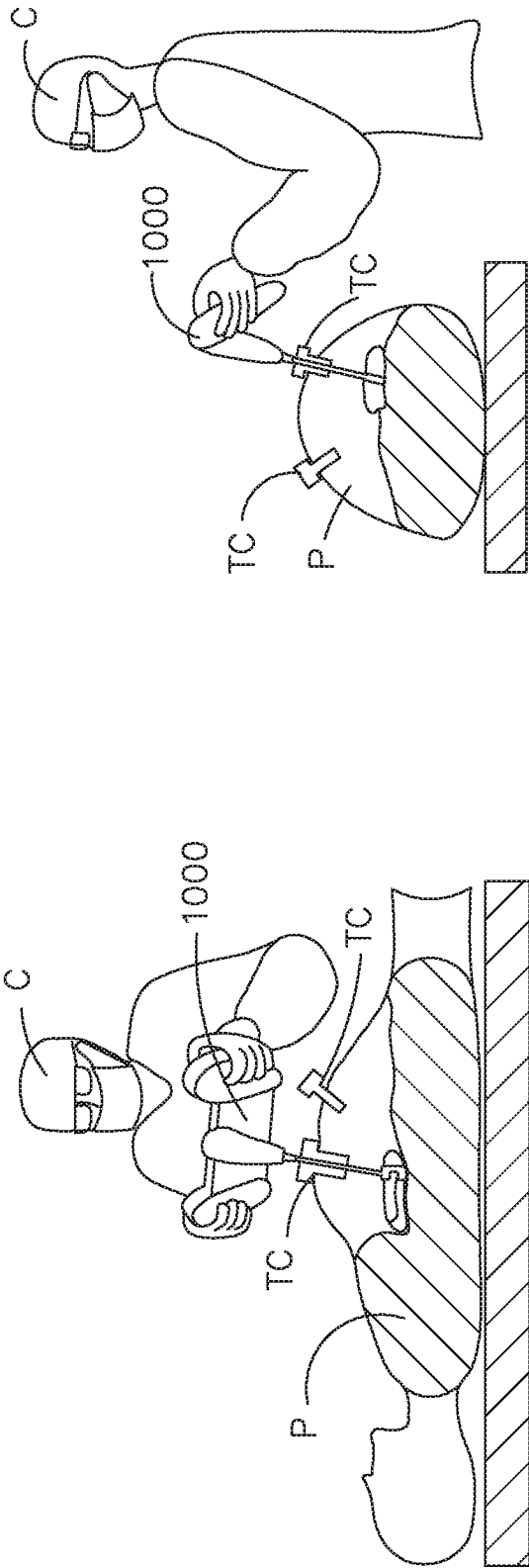

FIG. 145

FIG. 144

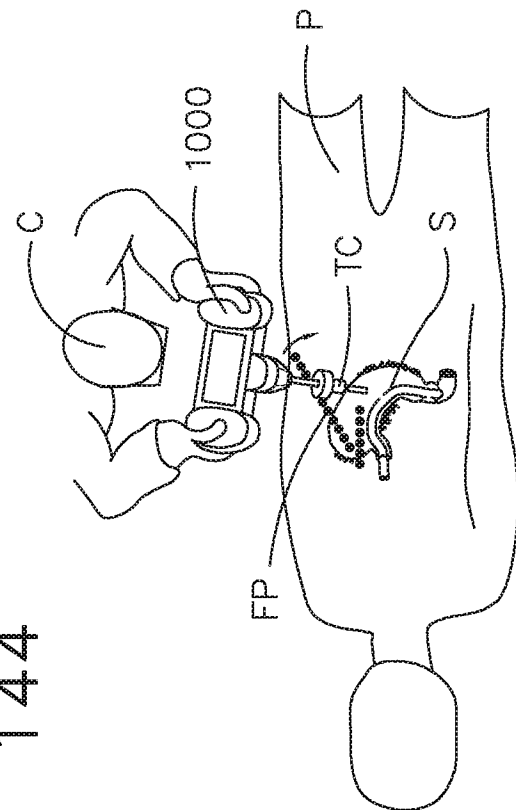
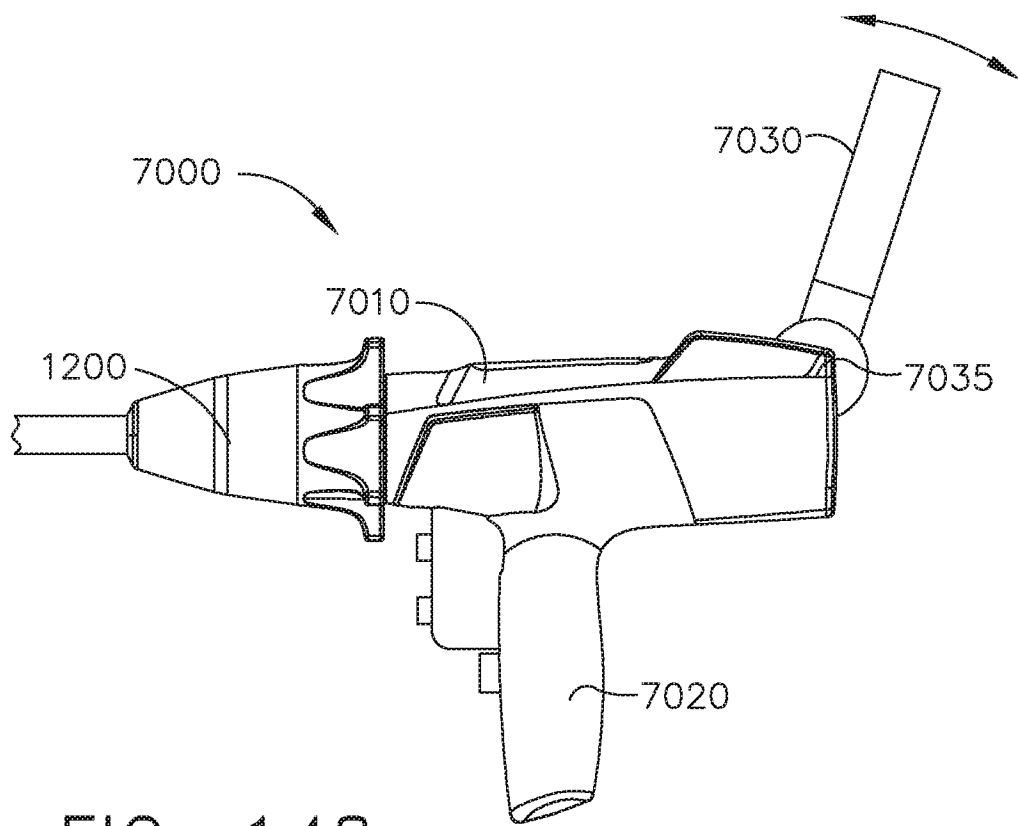
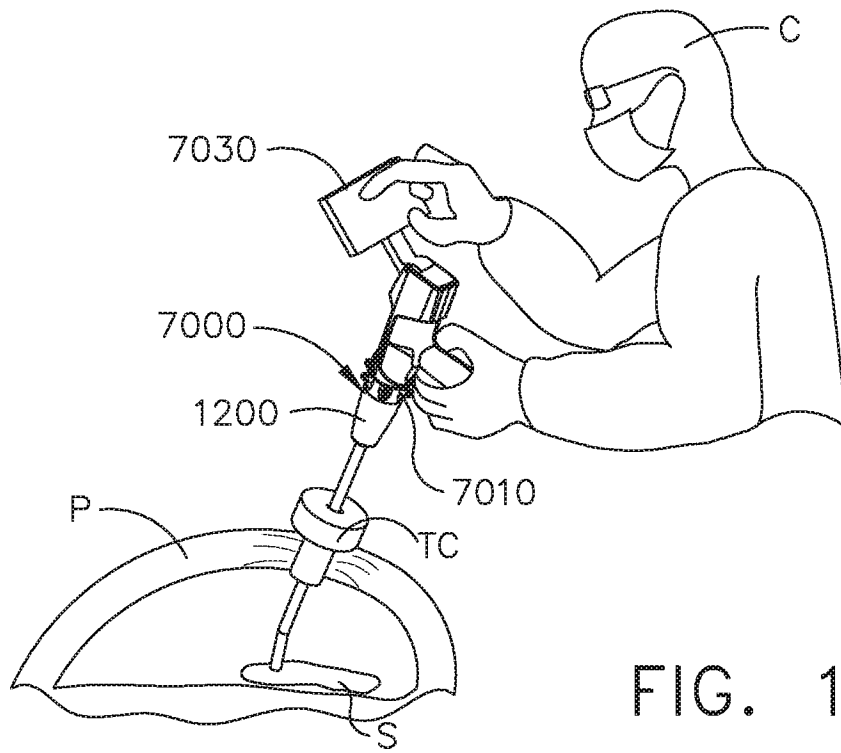

FIG. 146



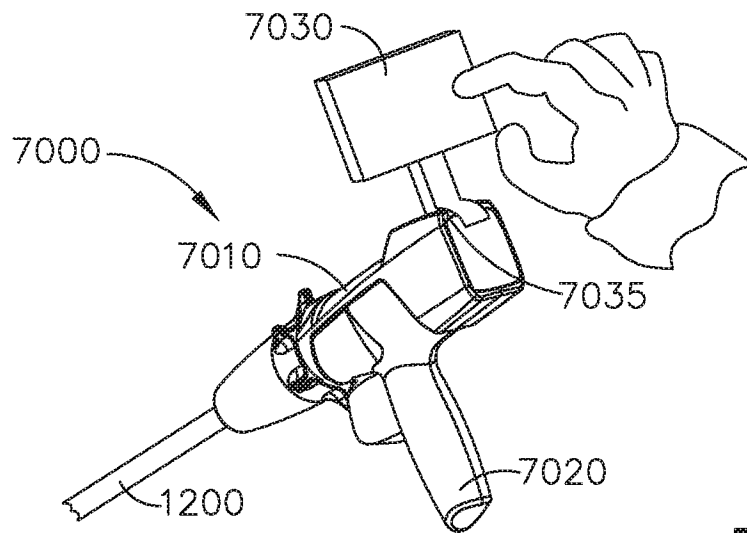

FIG. 149

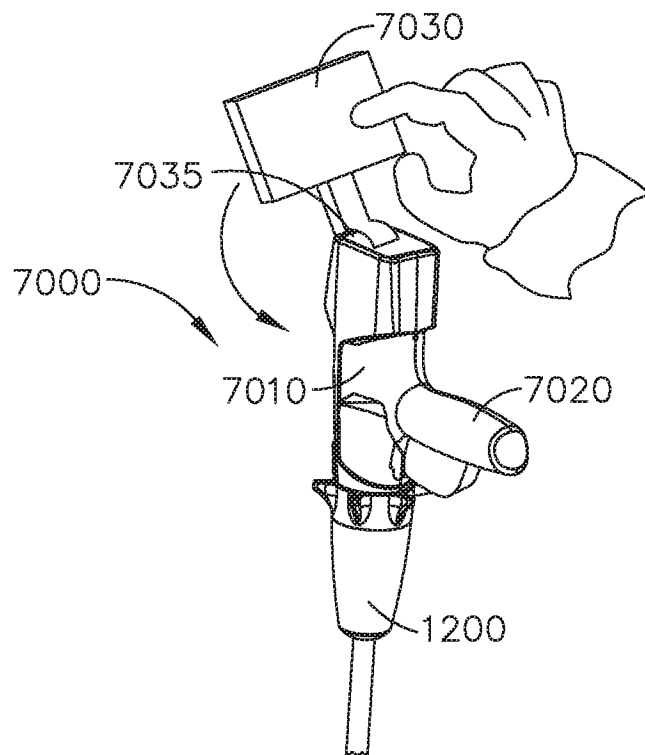

FIG. 150

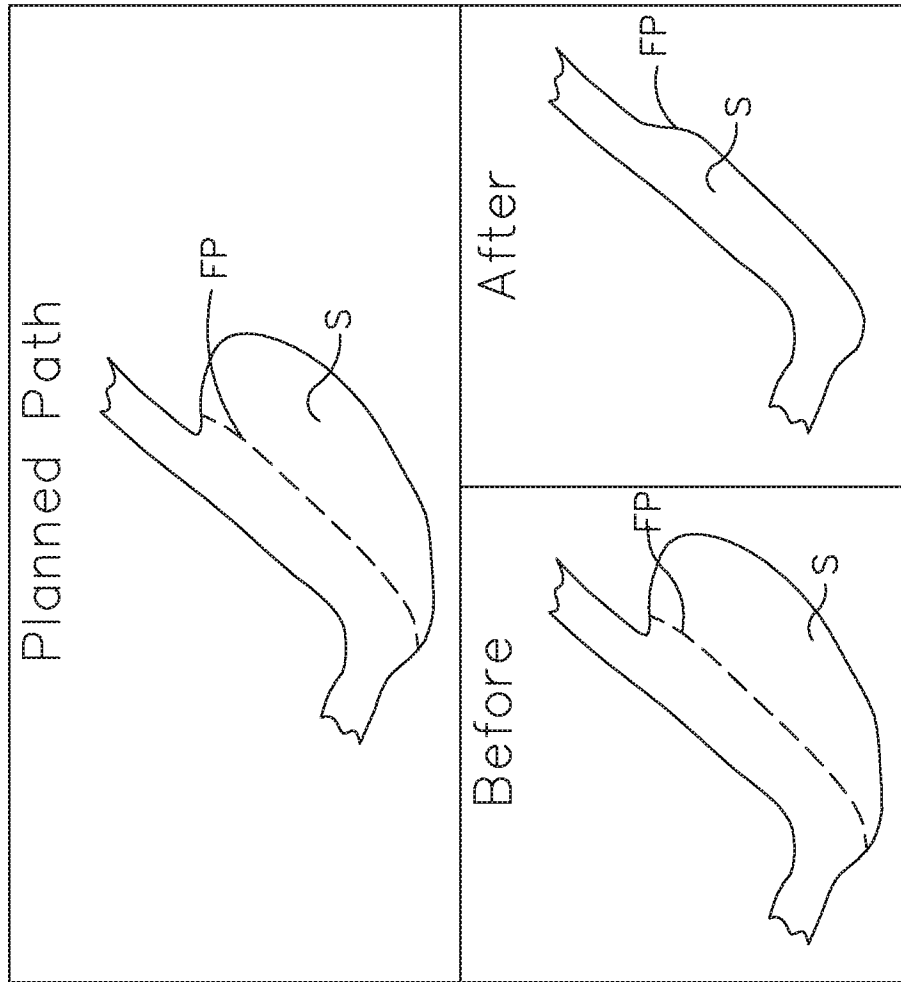

FIG. 151

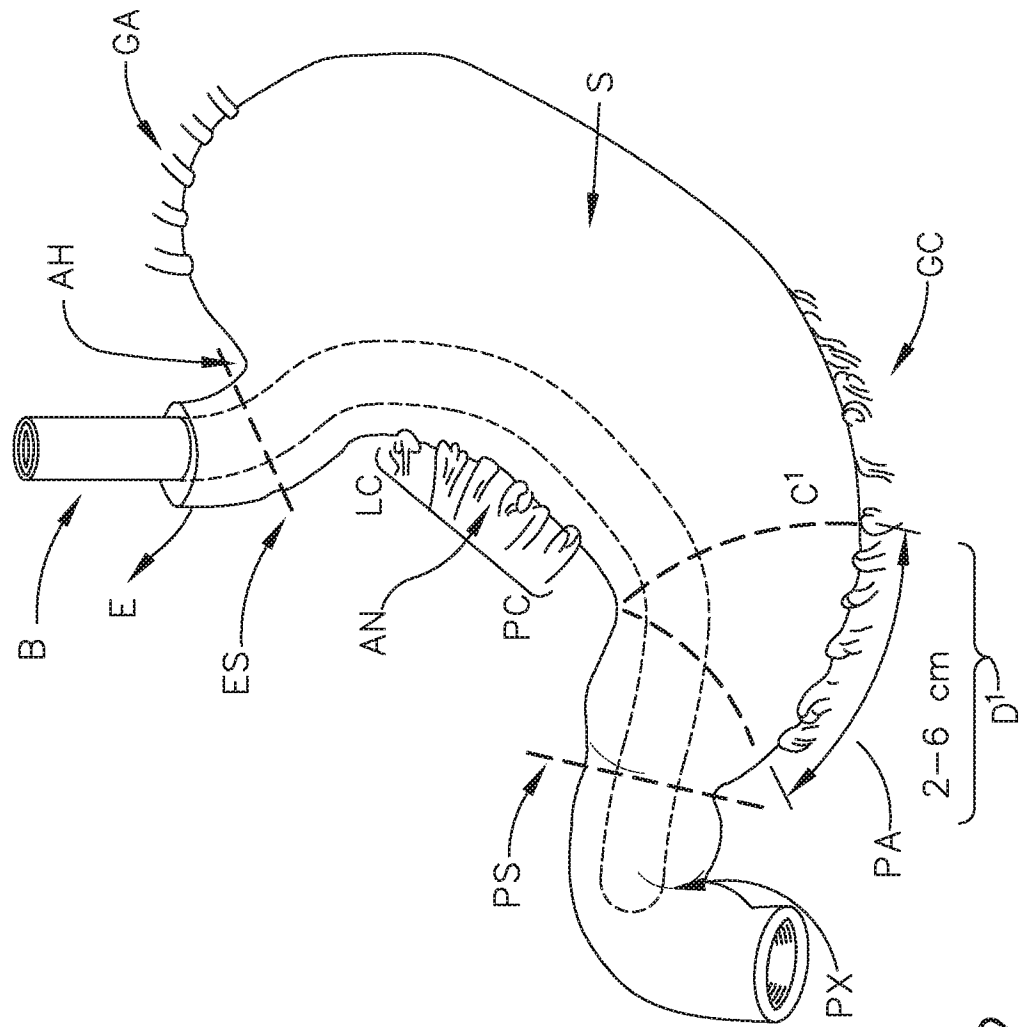

FIG. 152

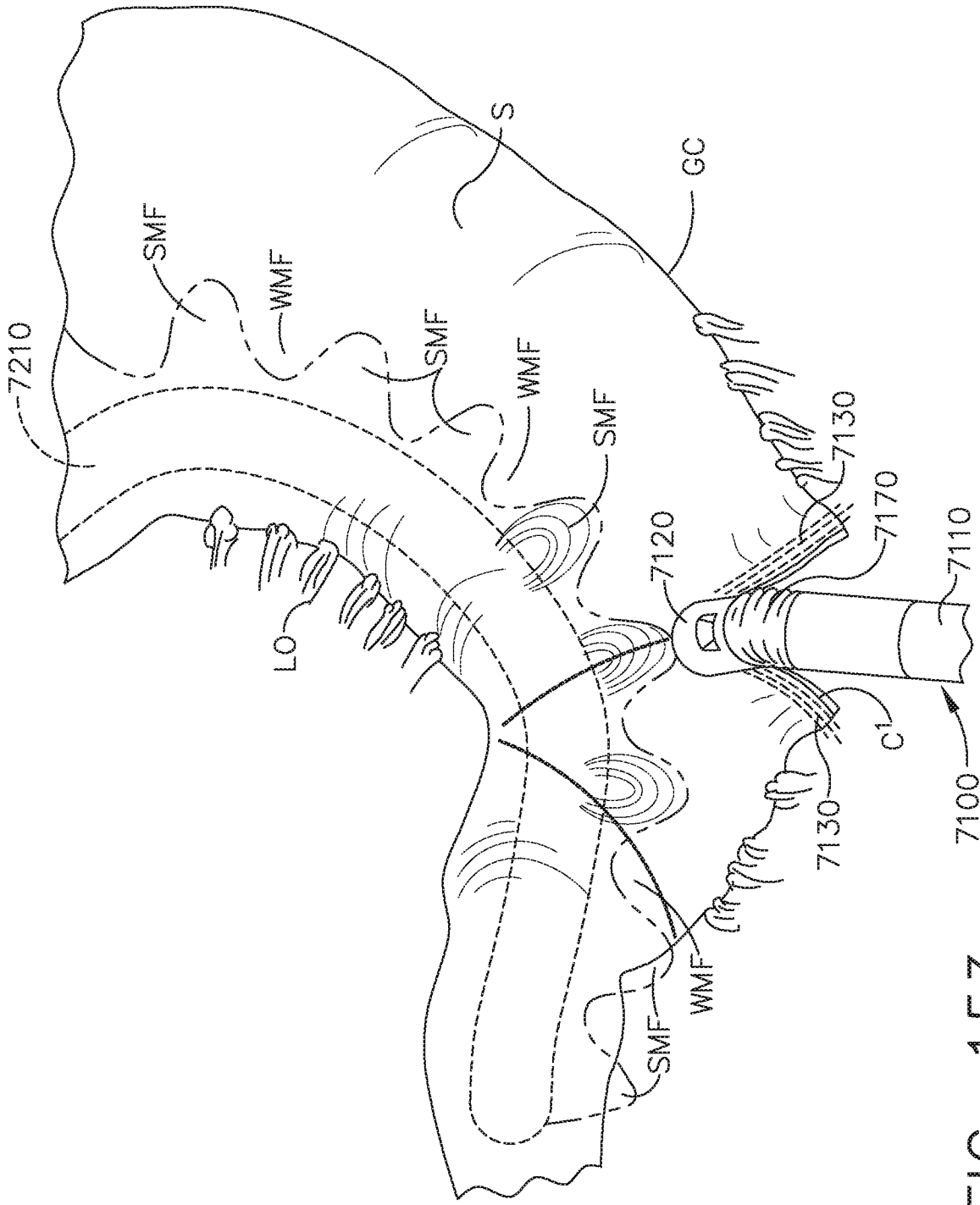

FIG. 153

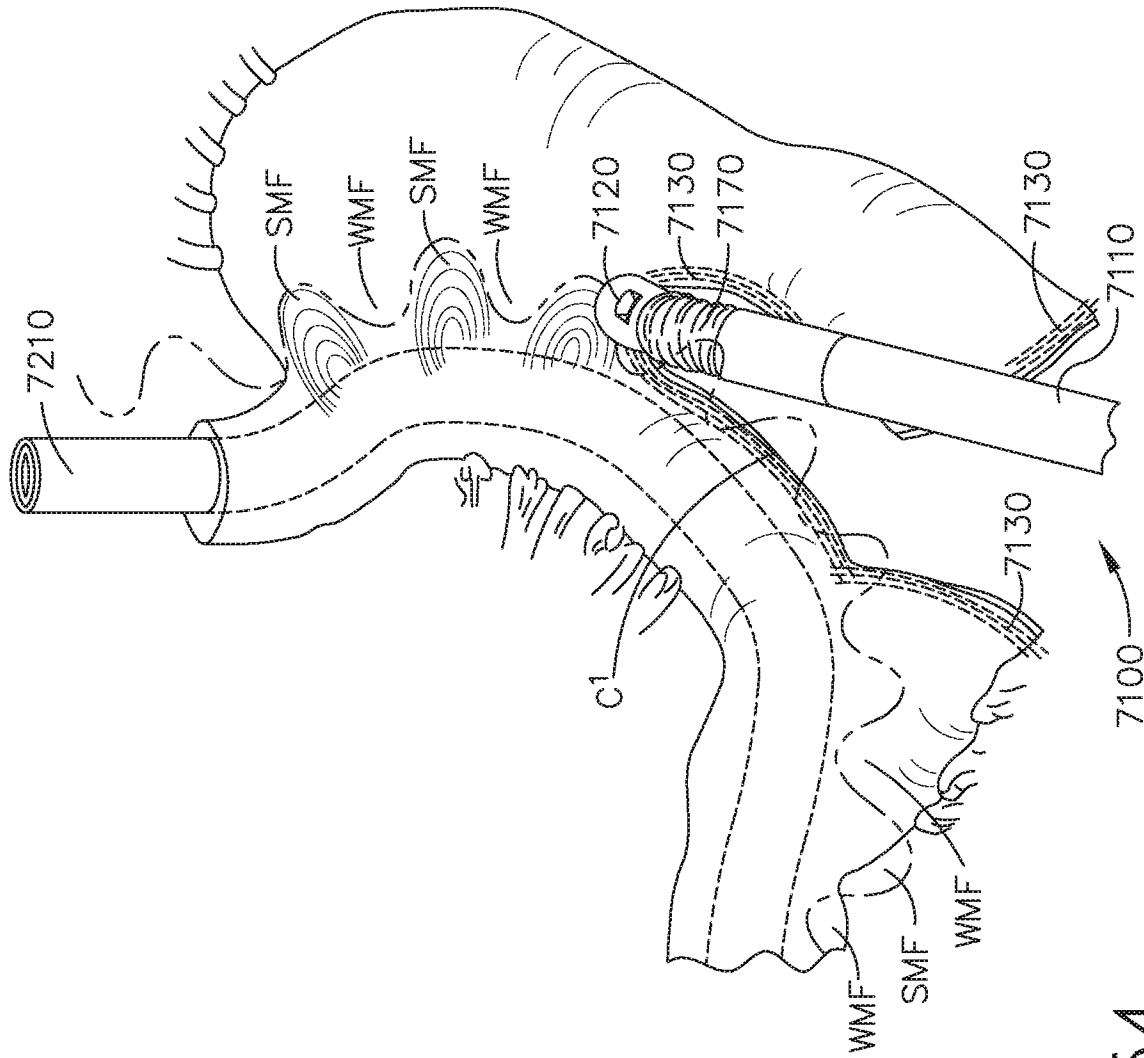

FIG. 154

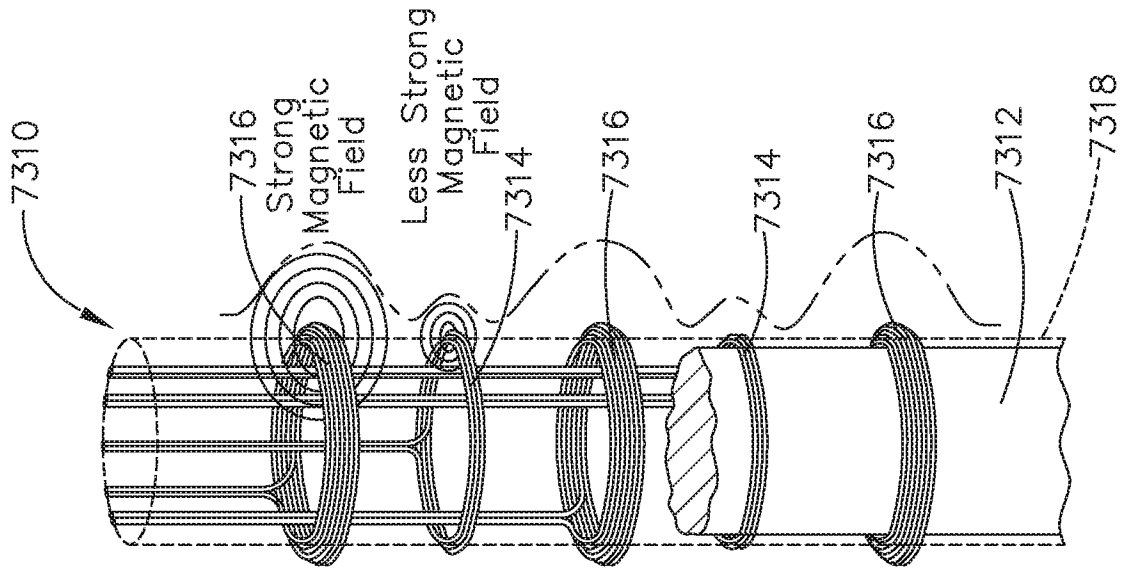

FIG. 156

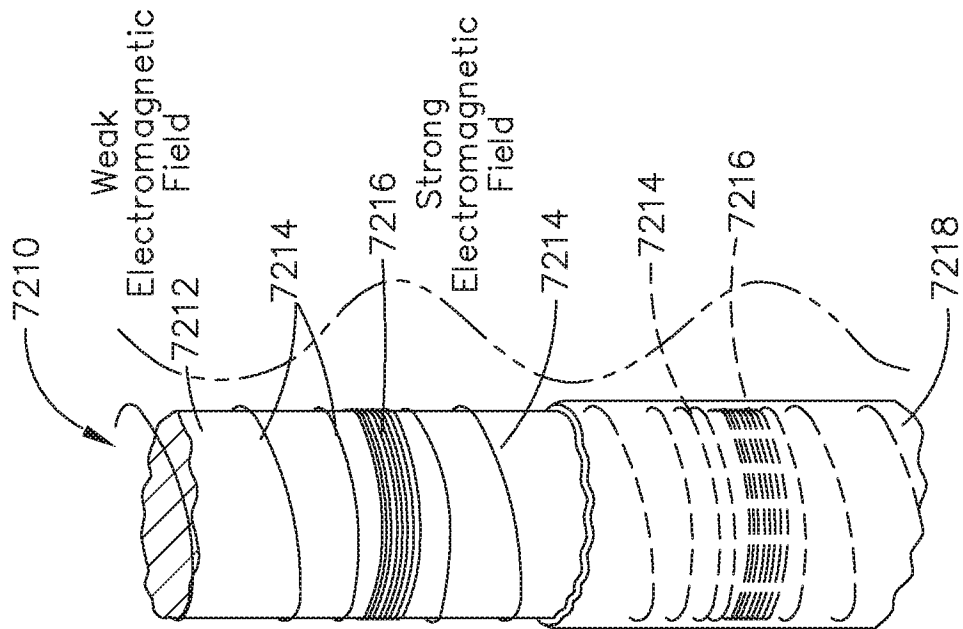

FIG. 155

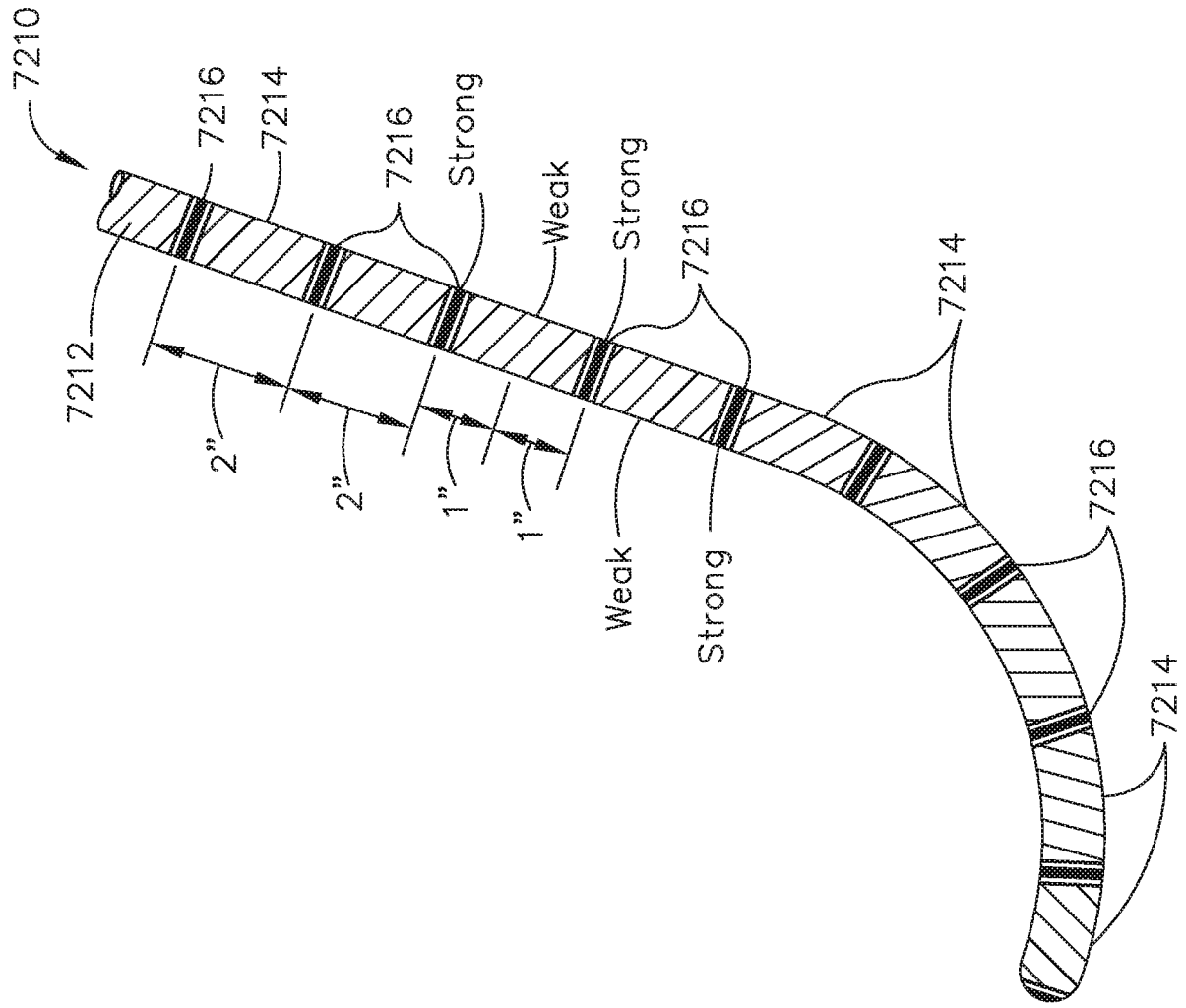

FIG. 157

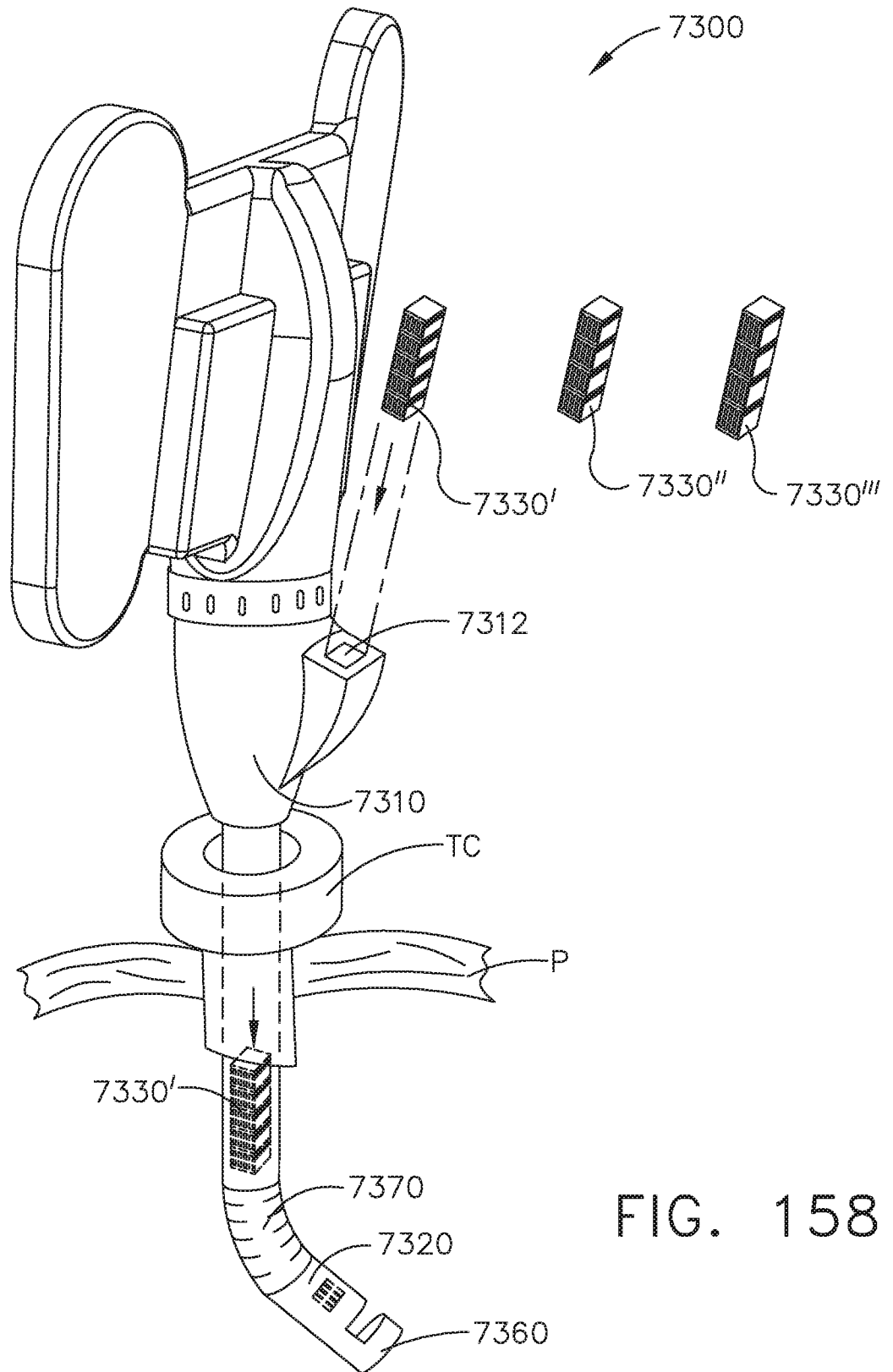

FIG. 158

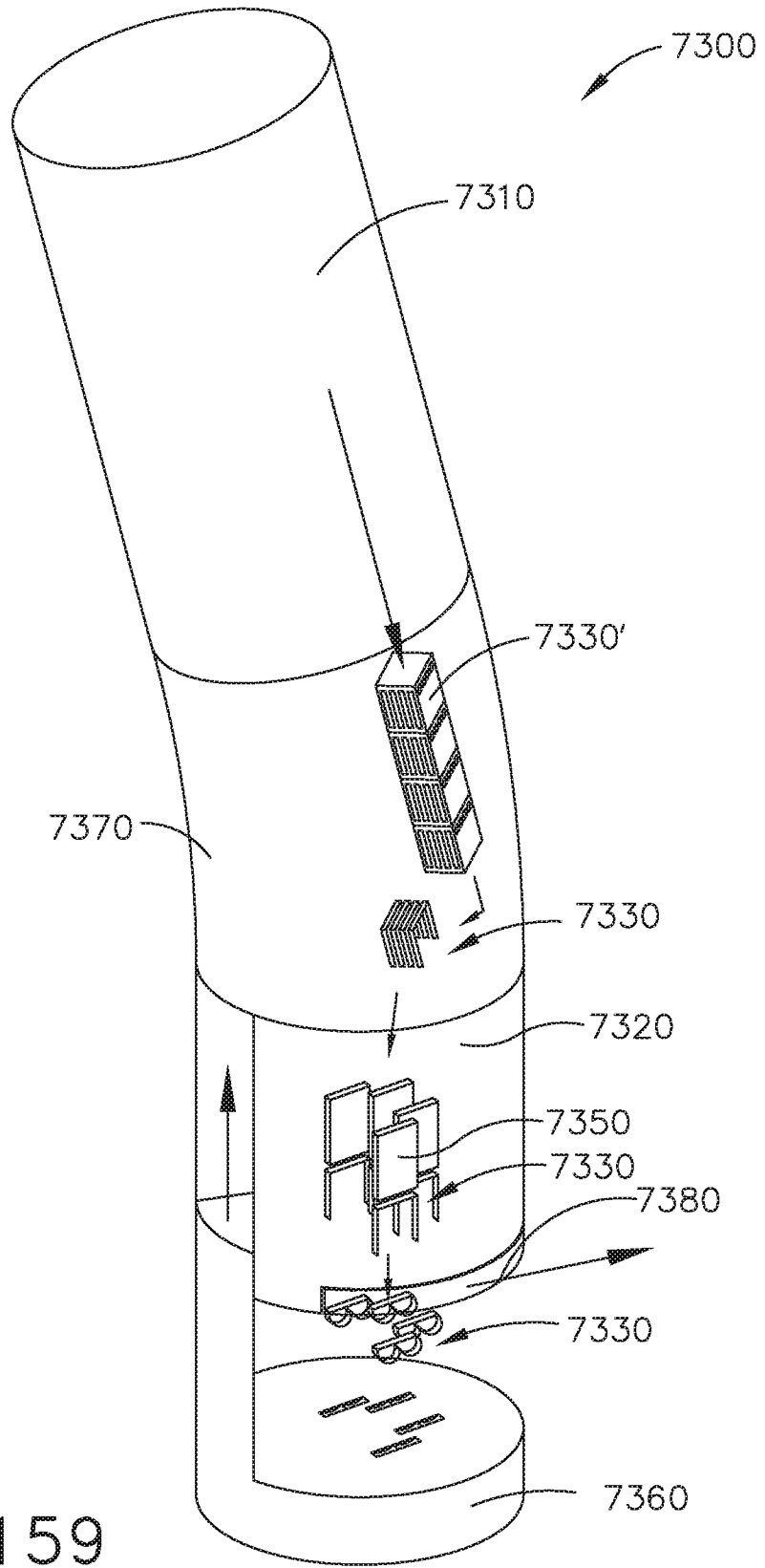

FIG. 159

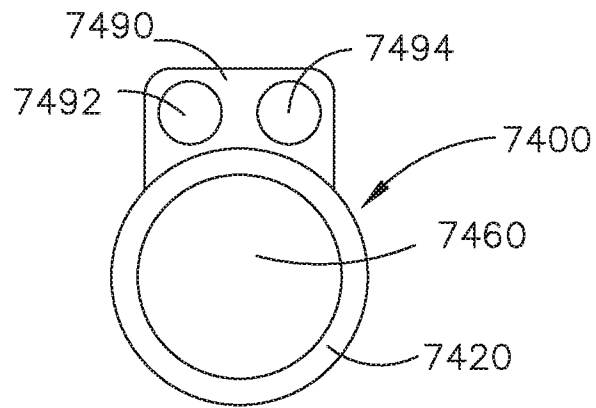

FIG. 160

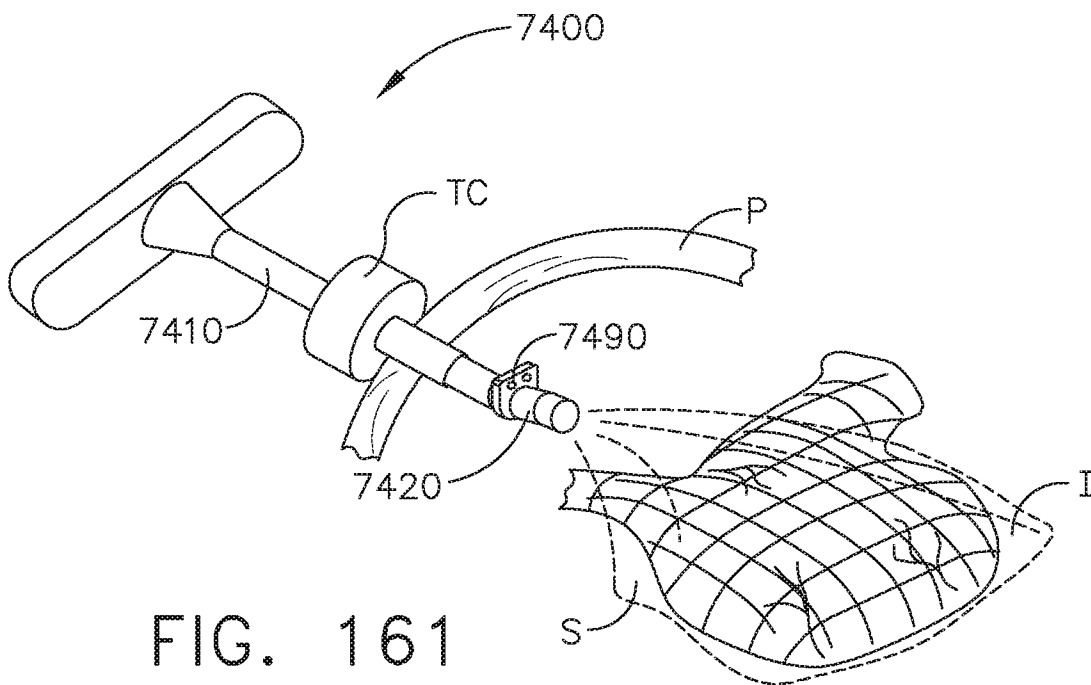

FIG. 161

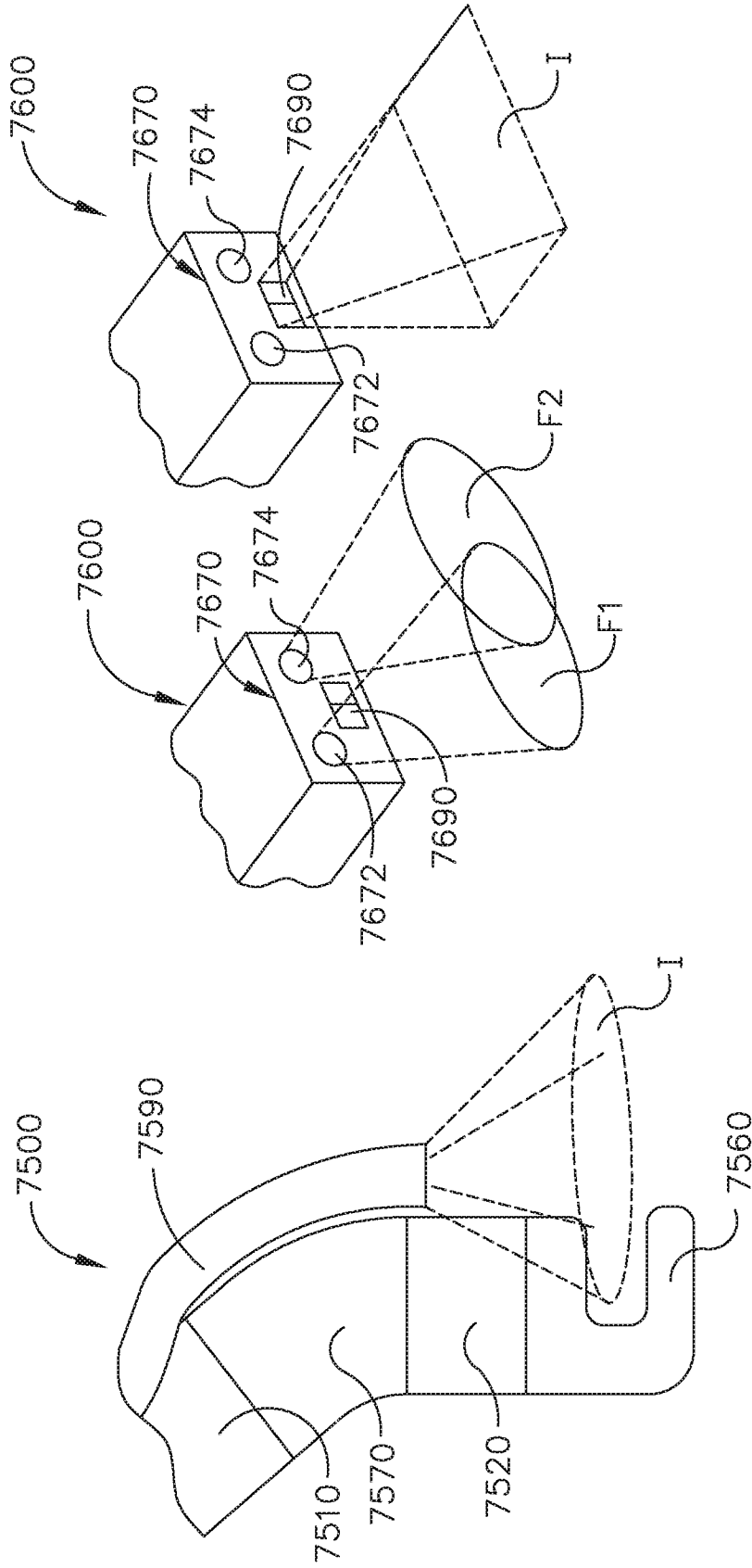

FIG. 162 FIG. 163 FIG. 164

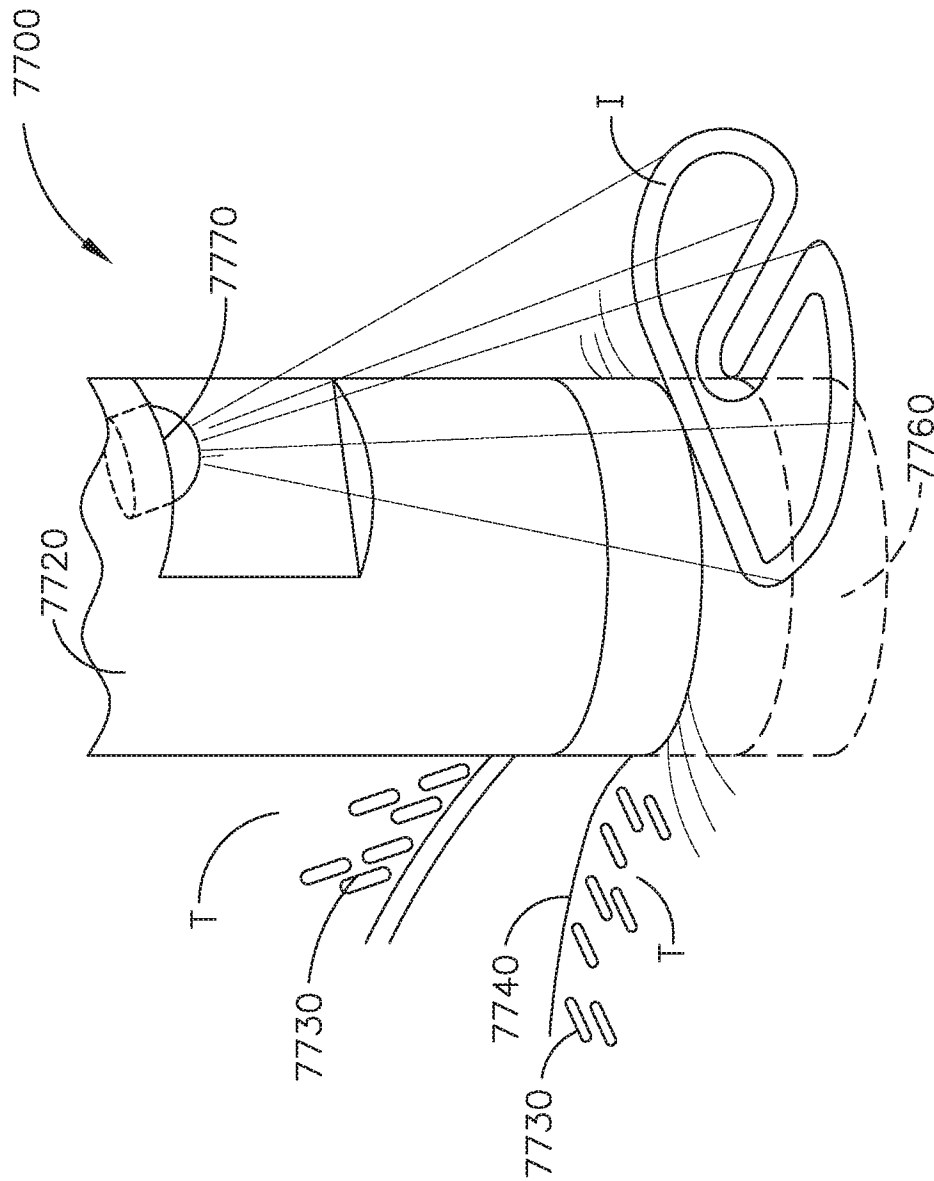

FIG. 165

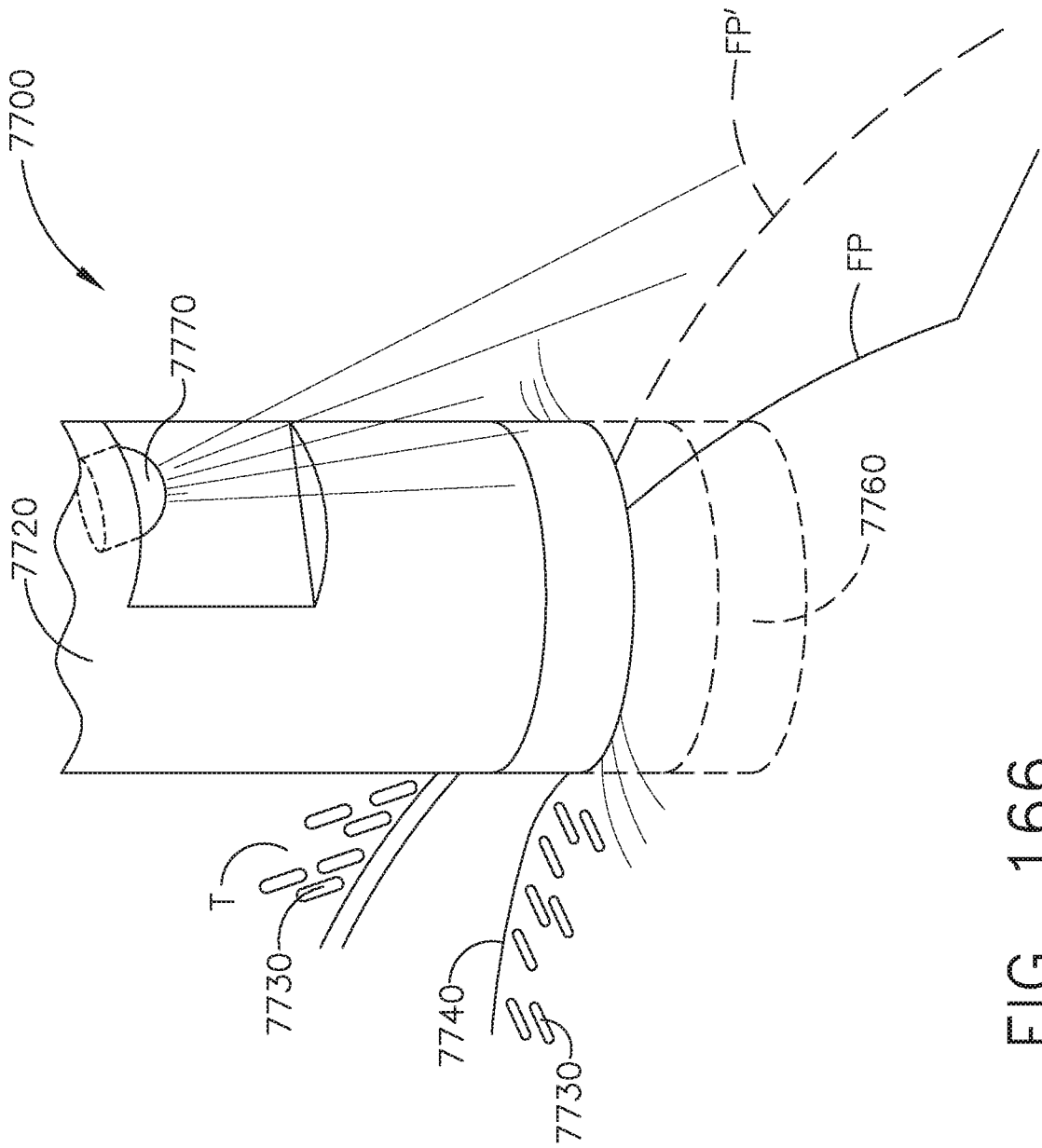

FIG. 166

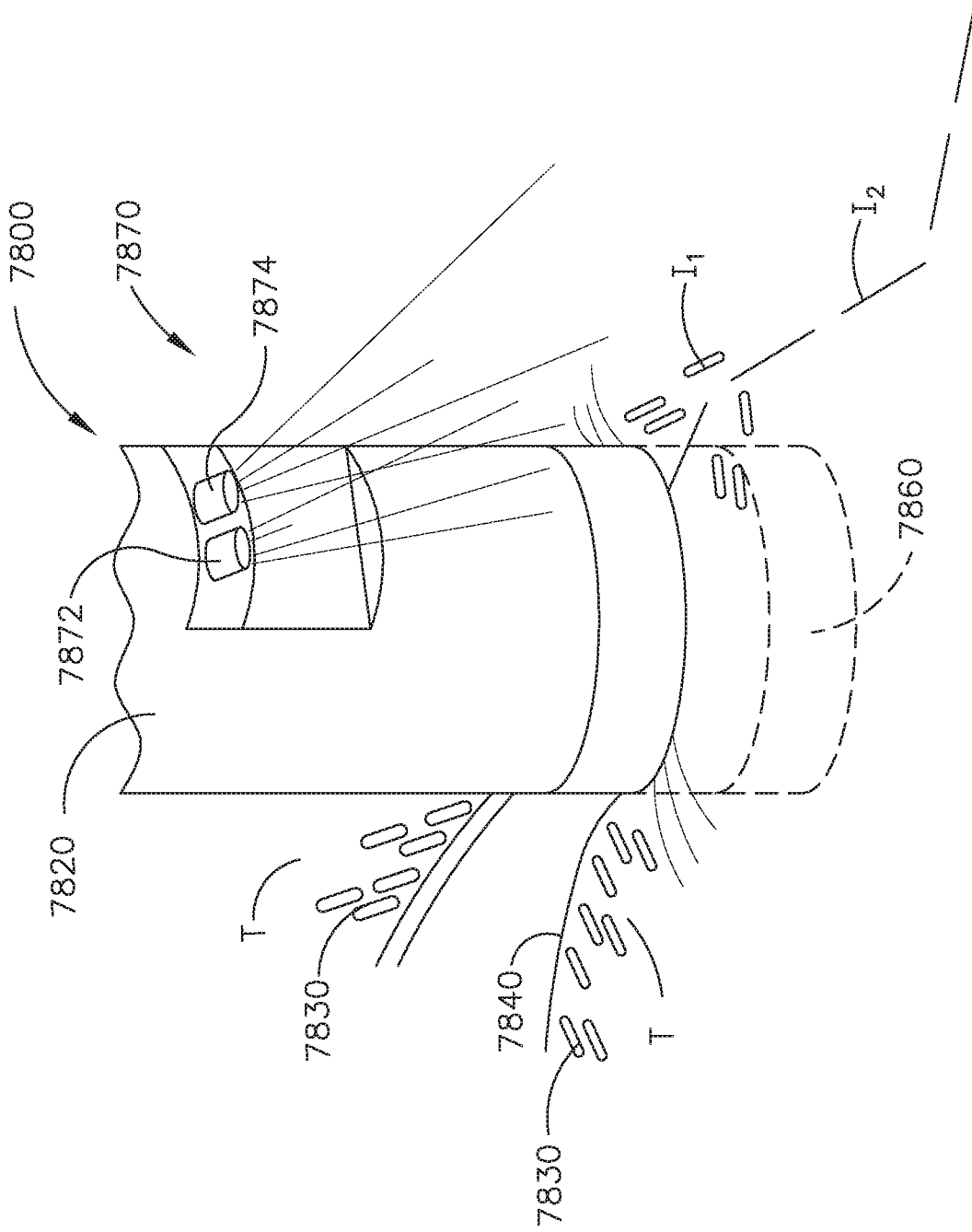

FIG. 167

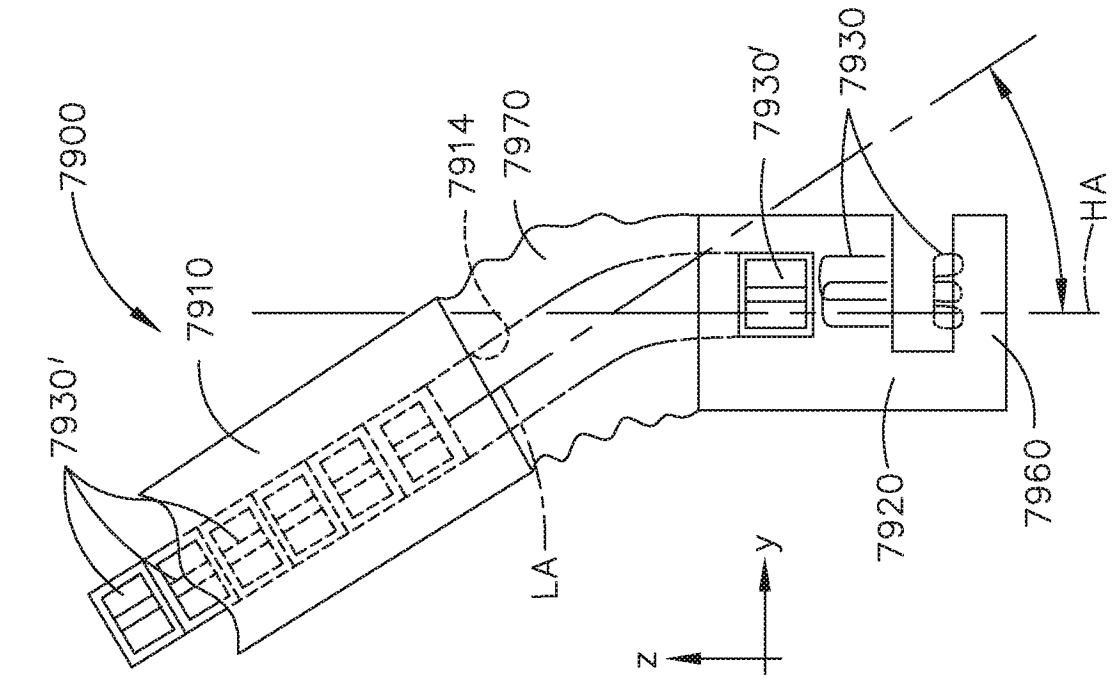

FIG. 168

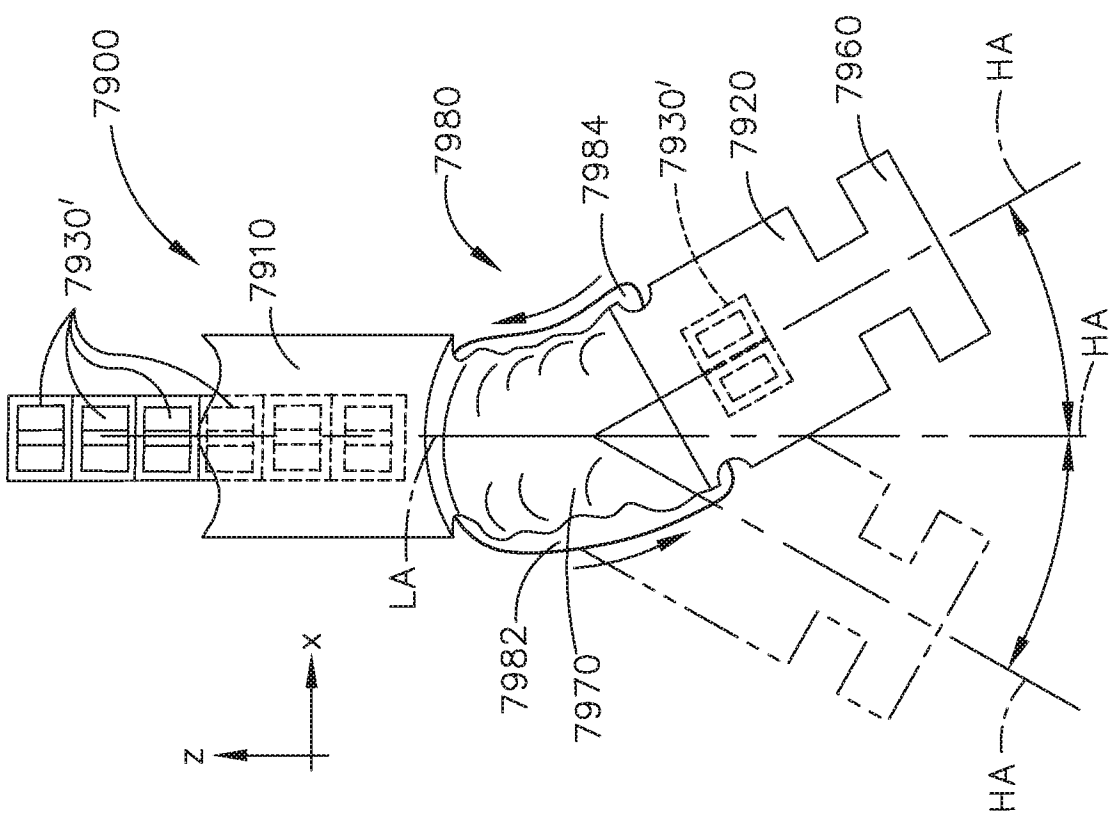

FIG. 169

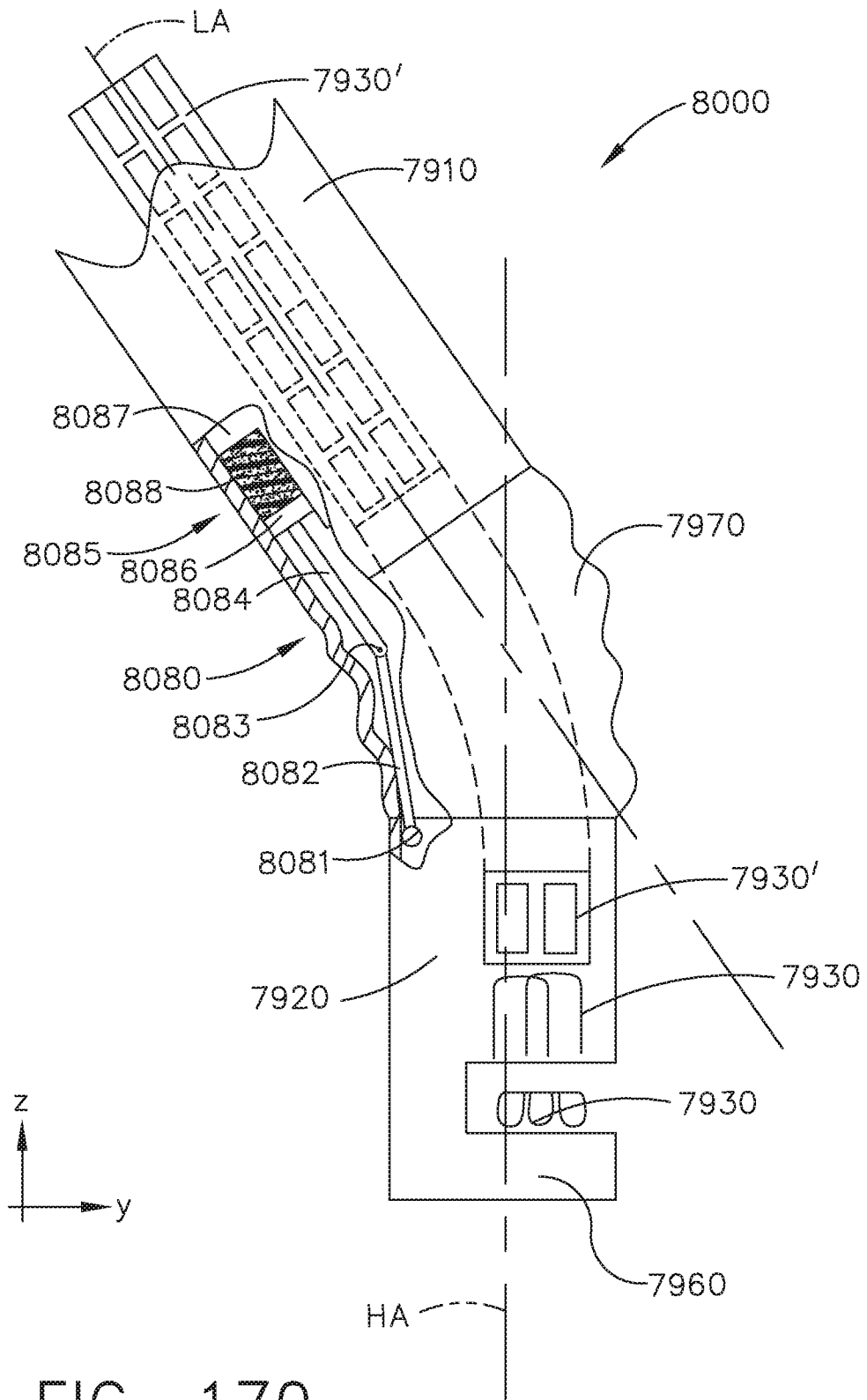

FIG. 170

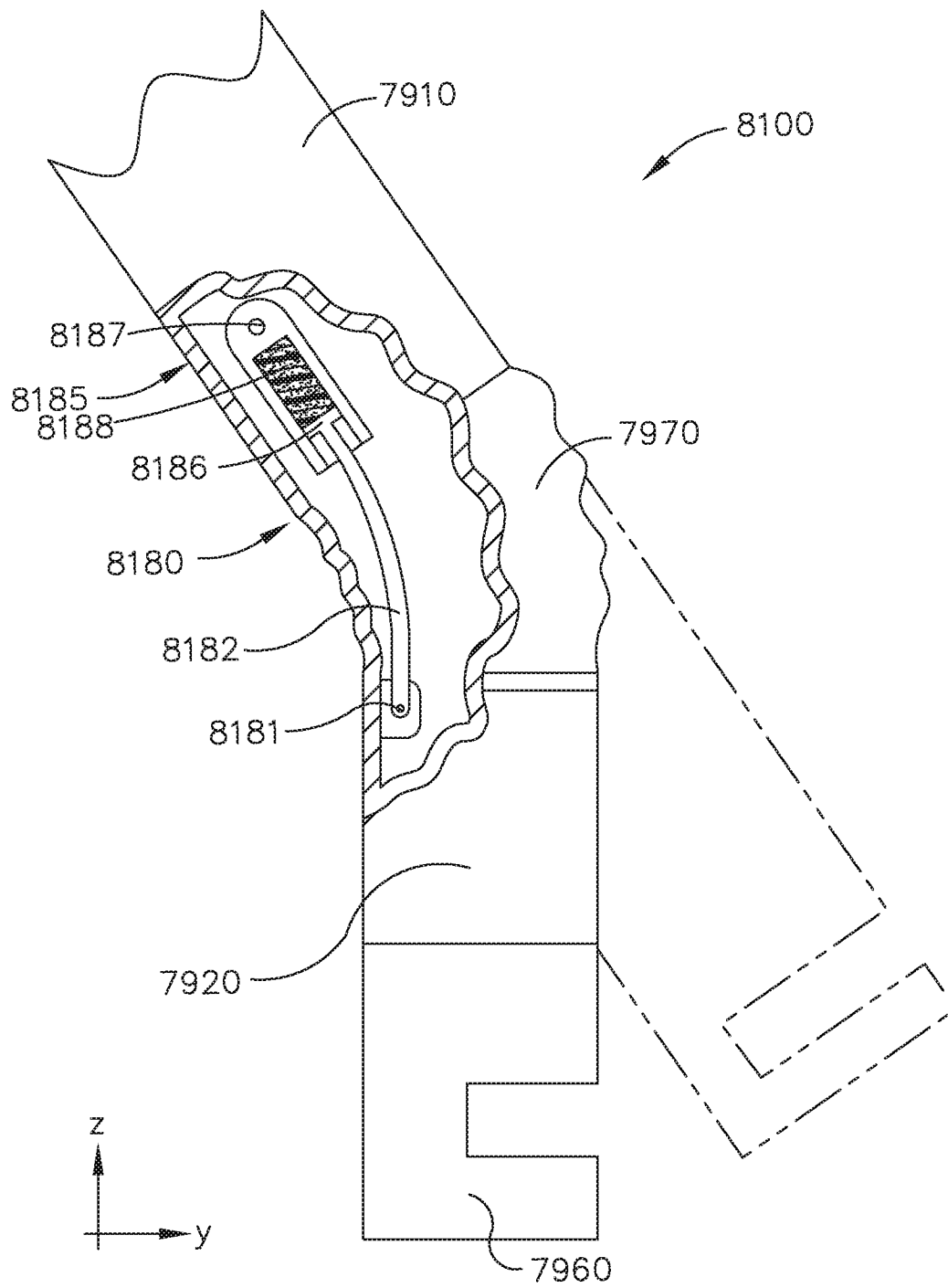

FIG. 171

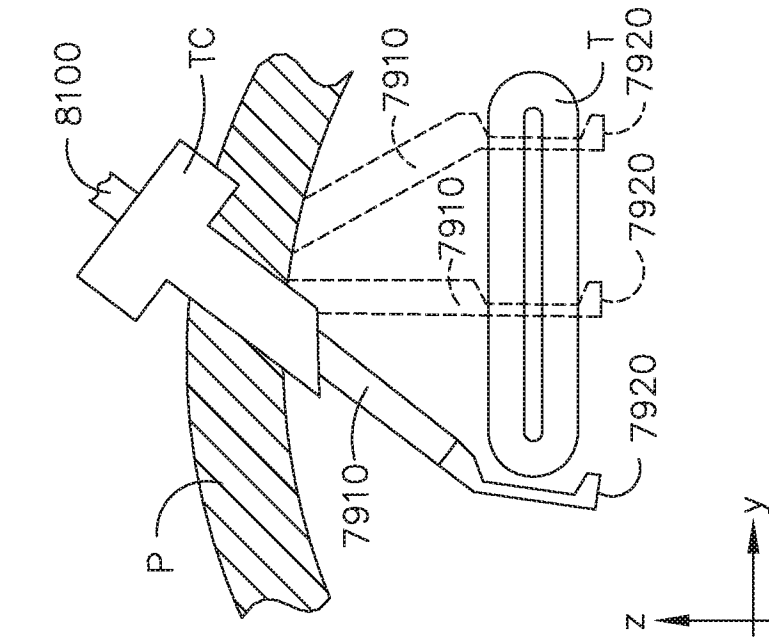

FIG. 172

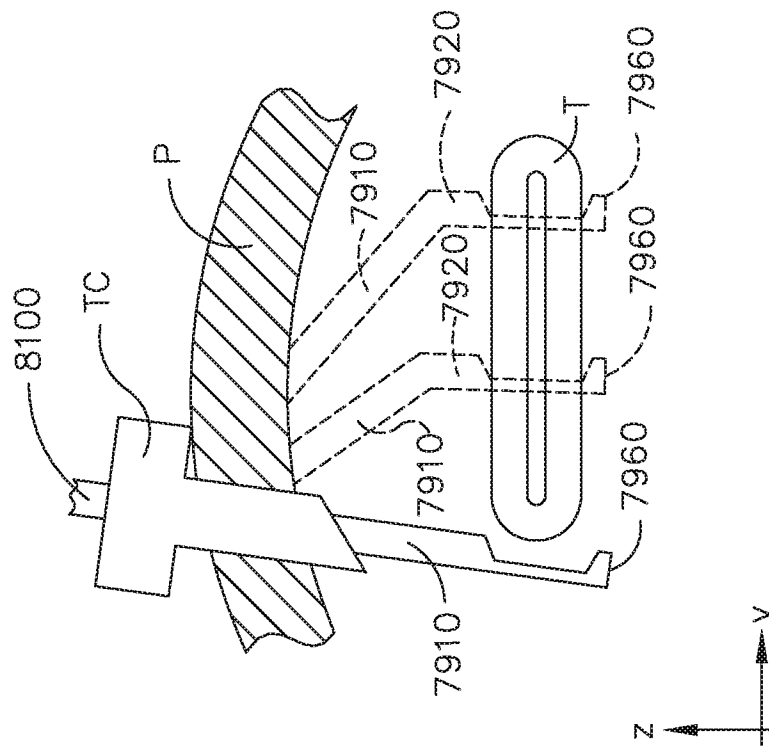

FIG. 173

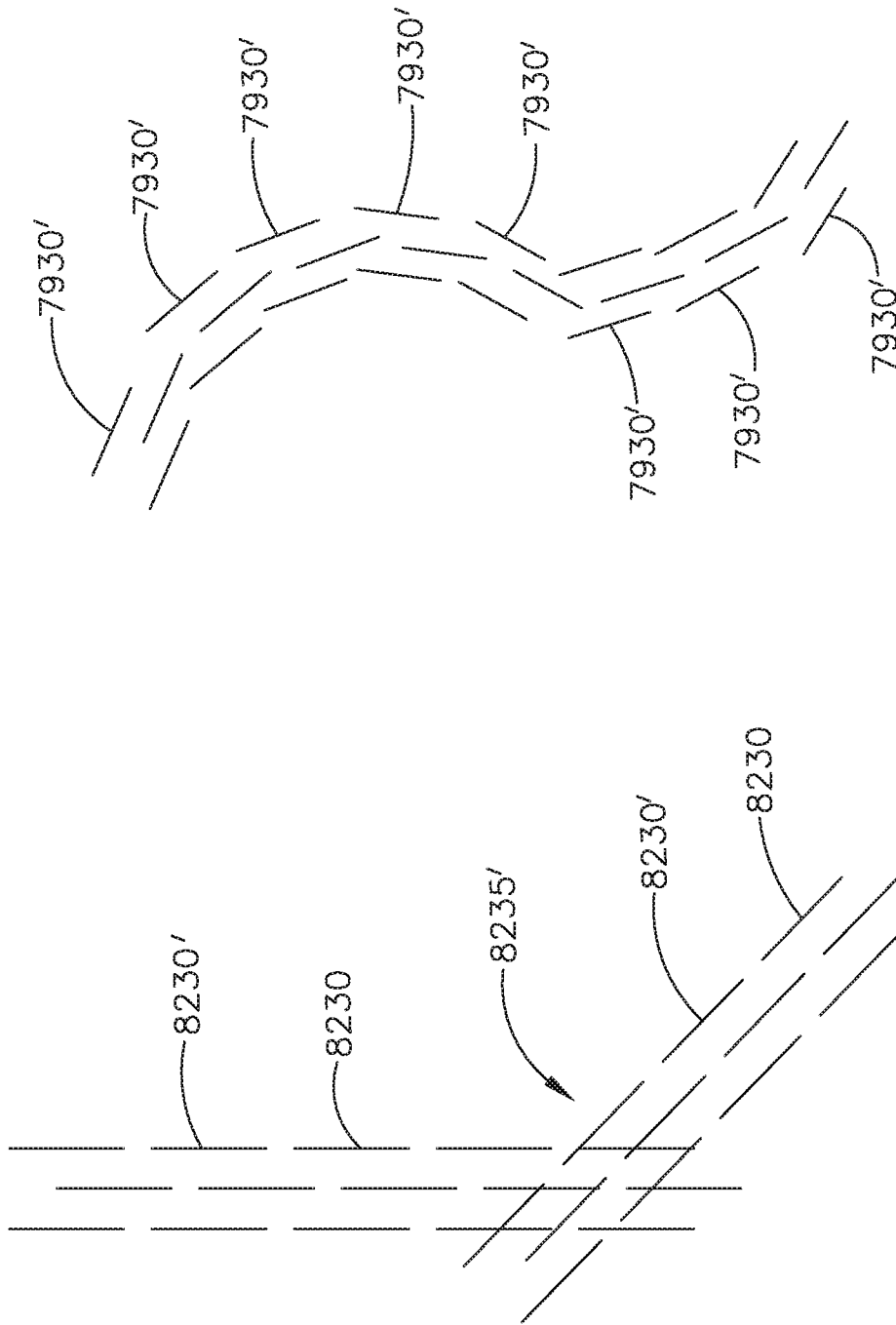

FIG. 175

FIG. 174

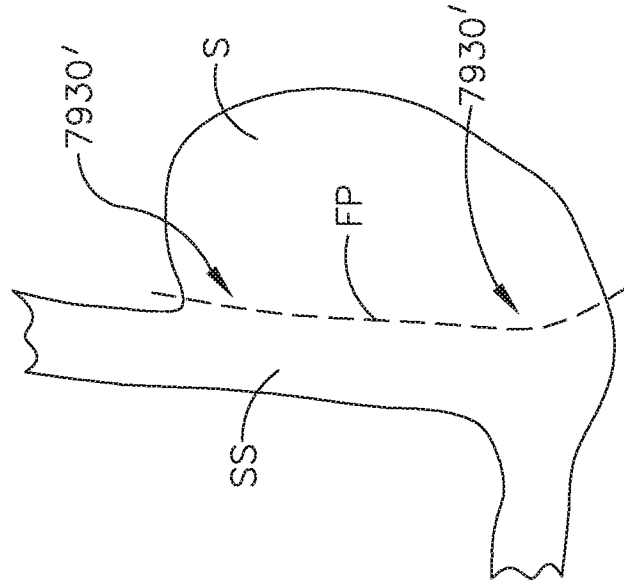

FIG. 177

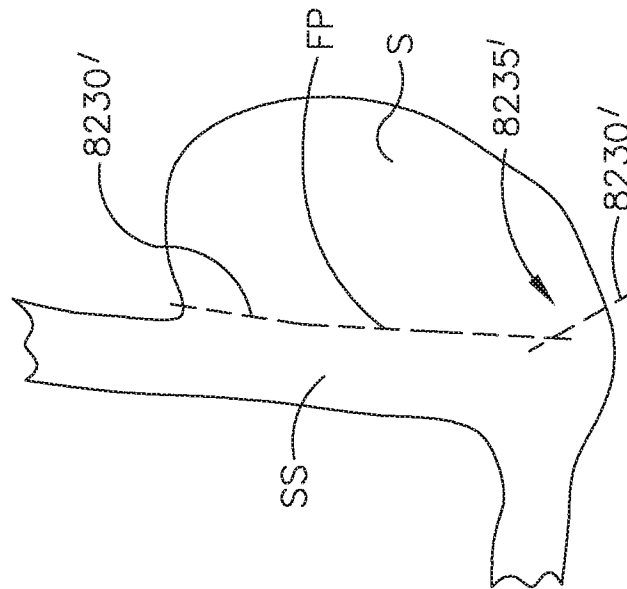

FIG. 176

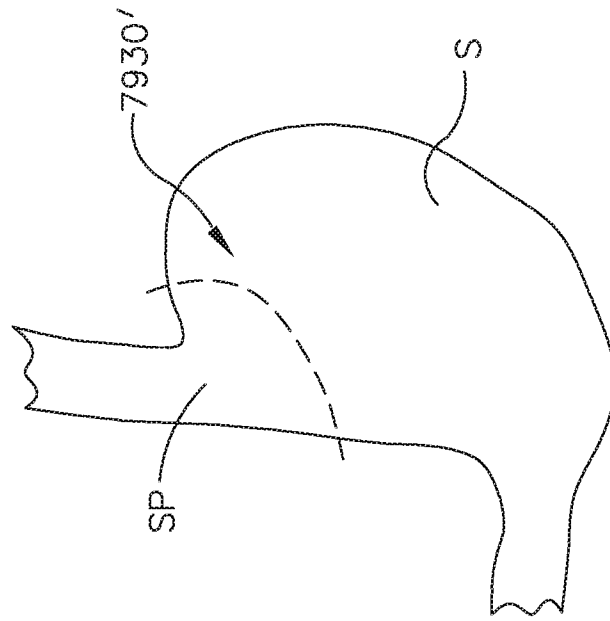

FIG. 179

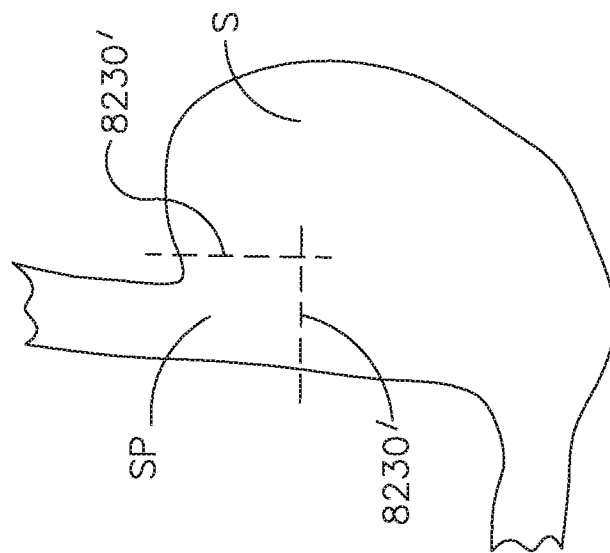

FIG. 178

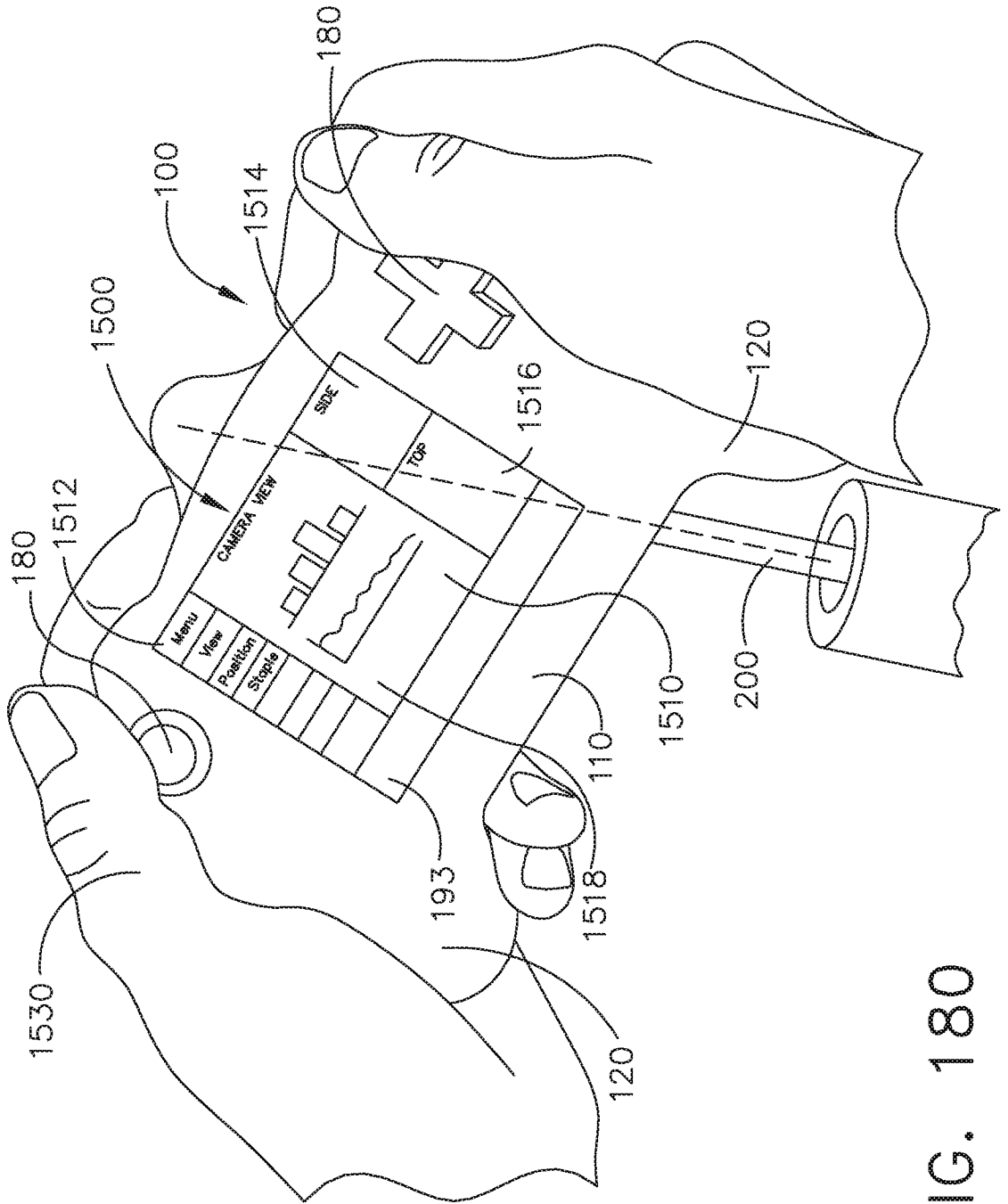

FIG. 180

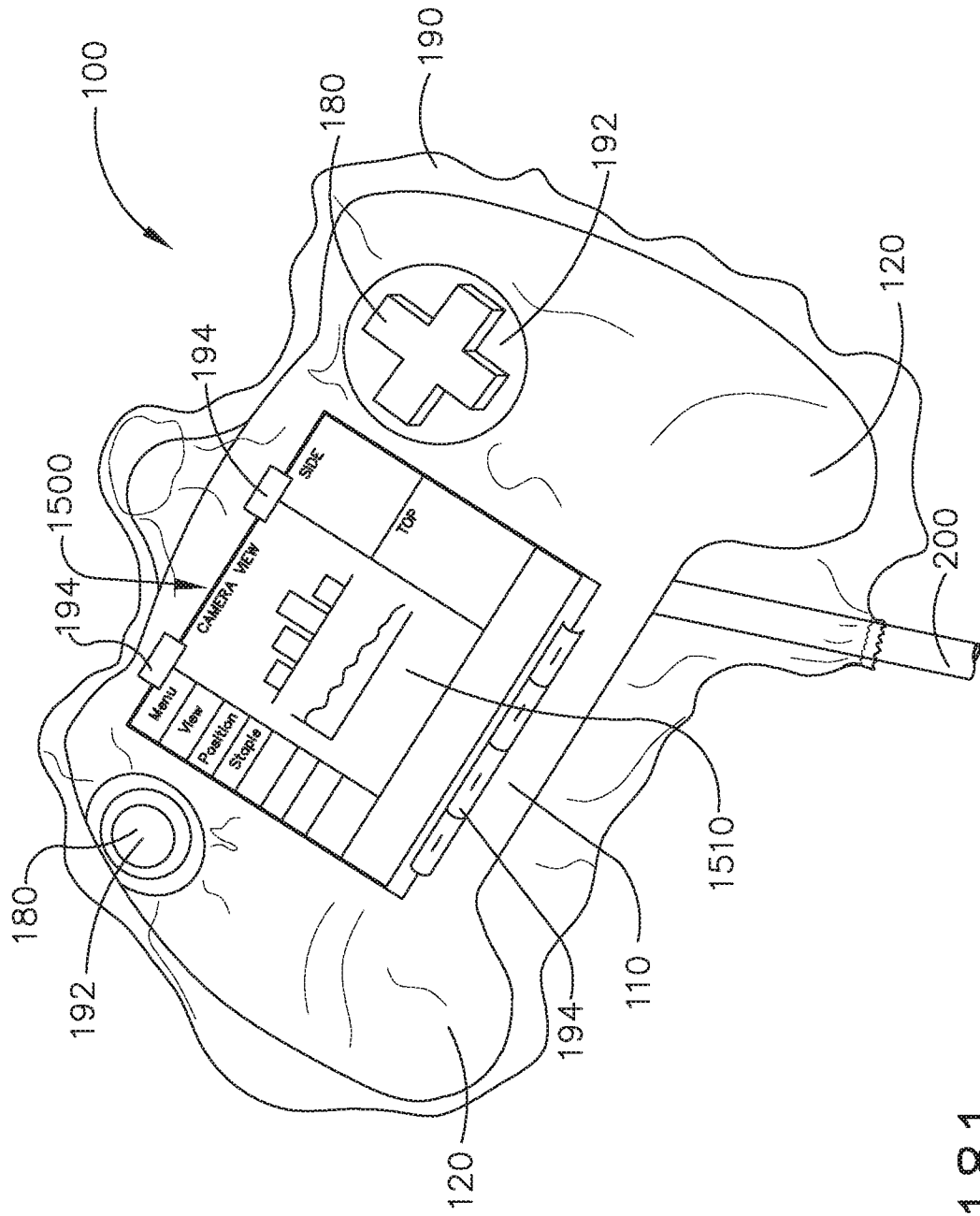

FIG. 181

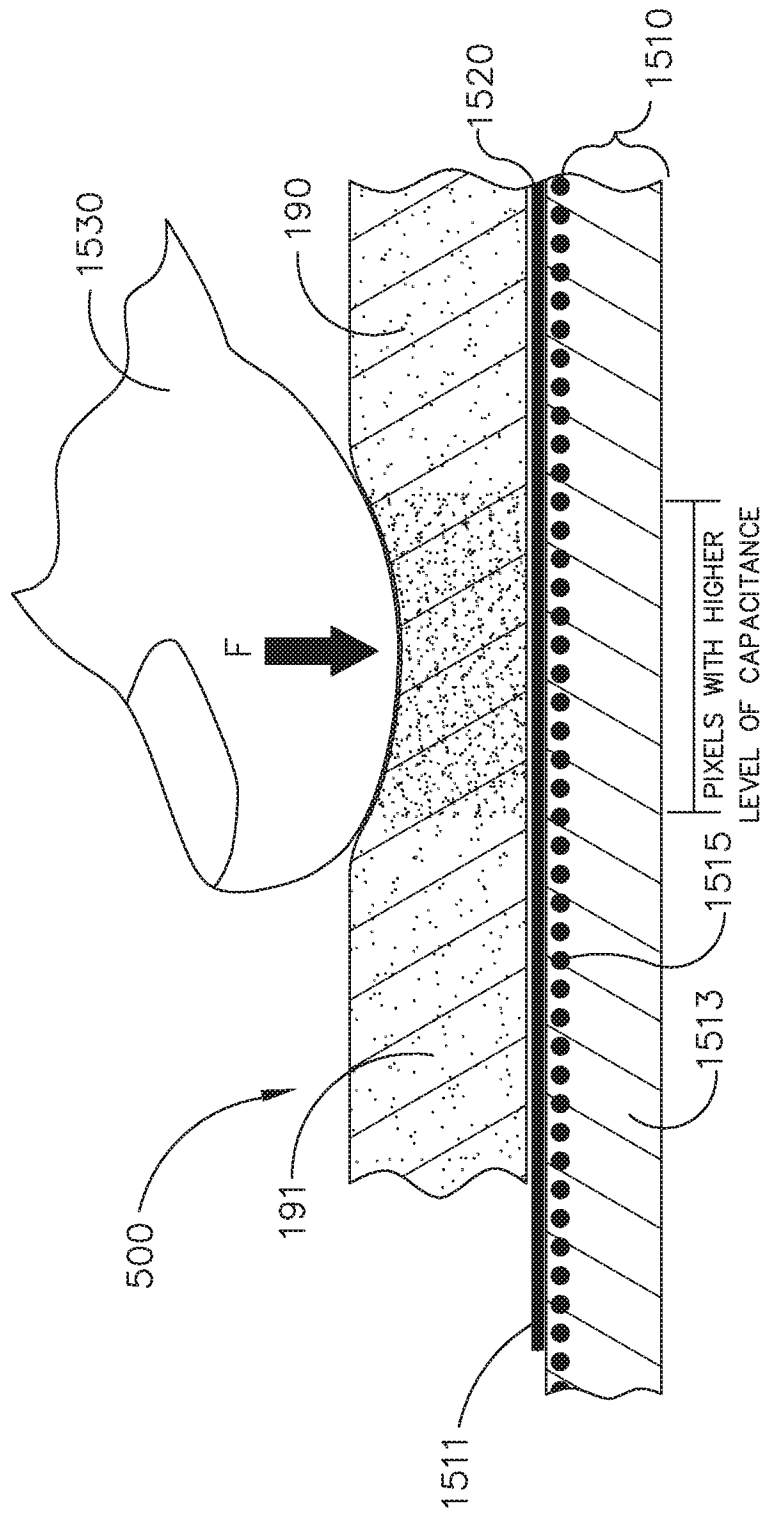

FIG. 182

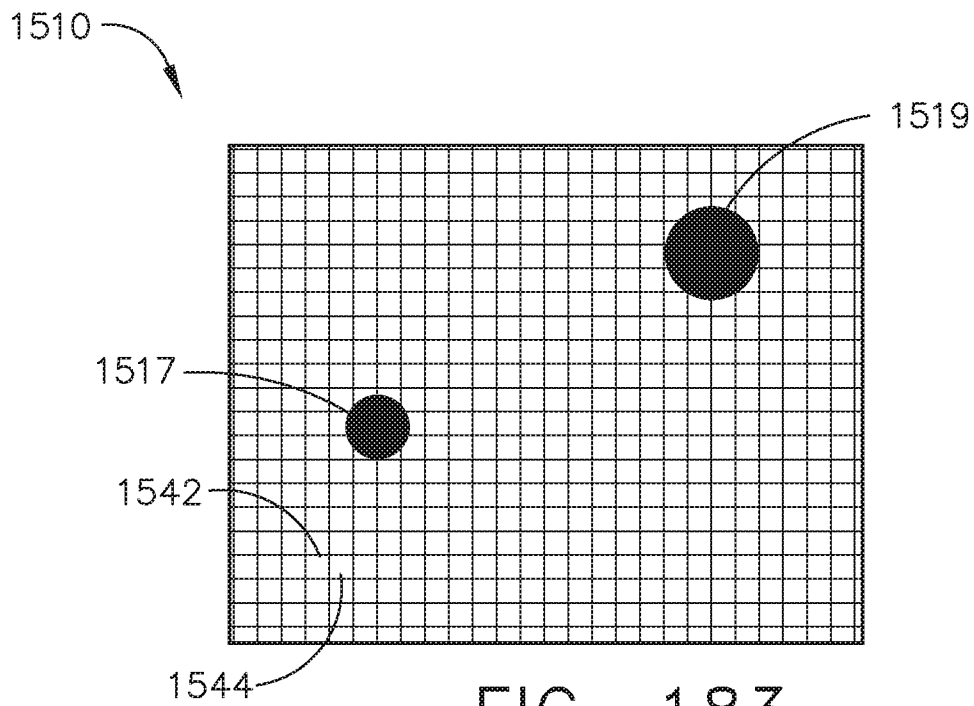

FIG. 183

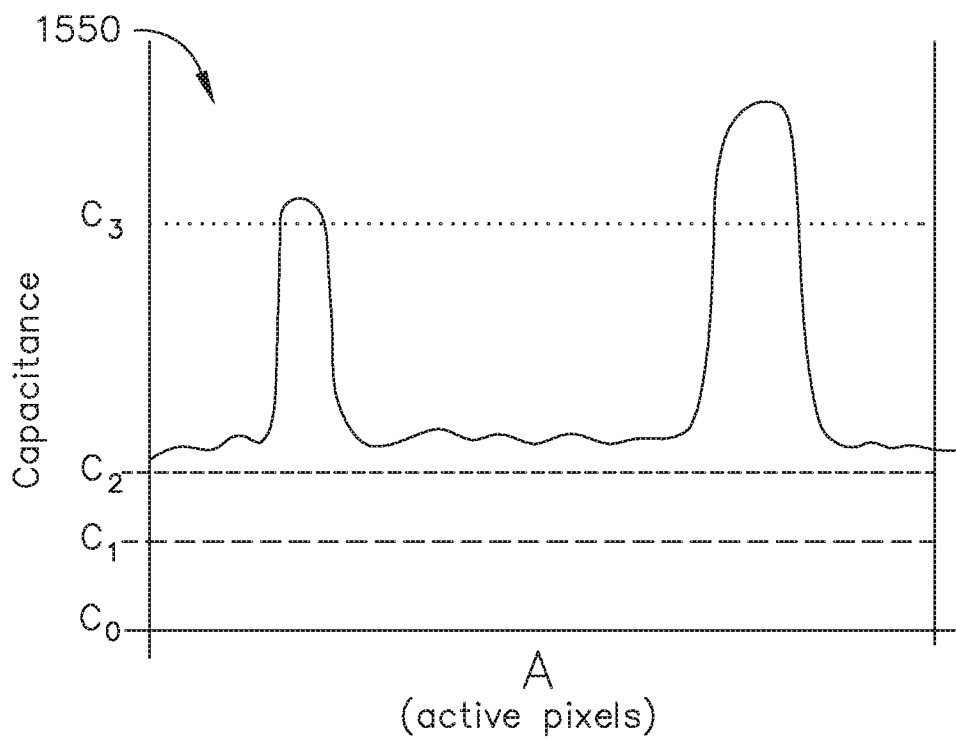

FIG. 184

**INTERNATIONAL SEARCH REPORT**

International application No  
PCT/IB2018/059839

**A. CLASSIFICATION OF SUBJECT MATTER**  
INV. A61B17/072  
ADD.  
  
According to International Patent Classification (IPC) or to both national classification and IPC

**B. FIELDS SEARCHED**  
Minimum documentation searched (classification system followed by classification symbols)  
A61B

Documentation searched other than minimum documentation to the extent that such documents are included in the fields searched

Electronic data base consulted during the international search (name of data base and, where practicable, search terms used)  
EPO-Internal, WPI Data

**C. DOCUMENTS CONSIDERED TO BE RELEVANT**

Category*	Citation of document, with indication, where appropriate, of the relevant passages	Relevant to claim No.
X	EP 2 157 918 A1 (BAROSENSE INC [US]) 3 March 2010 (2010-03-03) para. 16-18, 22; figures 3A-4A, 6A, 6B, 7A-9C -----	1-20
X A	WO 96/18344 A2 (MCGUCKIN JAMES F JR [US]) 20 June 1996 (1996-06-20) page 39, line 3 - page 41, line 2; figures 2, 15-18, 19, 28-31 -----	1-17,19, 20 18
X	US 2013/153642 A1 (FELDER KEVIN D [US] ET AL) 20 June 2013 (2013-06-20) para. 298-302; figures 51A-51C -----	1-20
	-/--	

Further documents are listed in the continuation of Box C.       See patent family annex.

\* Special categories of cited documents :

<p>"A" document defining the general state of the art which is not considered to be of particular relevance</p> <p>"E" earlier application or patent but published on or after the international filing date</p> <p>"L" document which may throw doubts on priority claim(s) or which is cited to establish the publication date of another citation or other special reason (as specified)</p> <p>"O" document referring to an oral disclosure, use, exhibition or other means</p> <p>"P" document published prior to the international filing date but later than the priority date claimed</p>	<p>"T" later document published after the international filing date or priority date and not in conflict with the application but cited to understand the principle or theory underlying the invention</p> <p>"X" document of particular relevance; the claimed invention cannot be considered novel or cannot be considered to involve an inventive step when the document is taken alone</p> <p>"Y" document of particular relevance; the claimed invention cannot be considered to involve an inventive step when the document is combined with one or more other such documents, such combination being obvious to a person skilled in the art</p> <p>"&amp;" document member of the same patent family</p>
---	---

Date of the actual completion of the international search  25 March 2019	Date of mailing of the international search report  04/04/2019
--	--

Name and mailing address of the ISA/ European Patent Office, P.B. 5818 Patentlaan 2 NL - 2280 HV Rijswijk Tel. (+31-70) 340-2040, Fax: (+31-70) 340-3016	Authorized officer  Kamp, Martin
--	--

## INTERNATIONAL SEARCH REPORT

International application No  
PCT/IB2018/059839

C(Continuation). DOCUMENTS CONSIDERED TO BE RELEVANT		
Category*	Citation of document, with indication, where appropriate, of the relevant passages	Relevant to claim No.
X	US 2010/168768 A1 (SONNENSCHNEIDER ELAZAR [IL] ET AL) 1 July 2010 (2010-07-01) para. 87-99; figures 7-12F -----	1-13, 15, 17-20
X	EP 1 815 803 A1 (NDO SURGICAL INC [US]) 8 August 2007 (2007-08-08) para. 129, 130, 140-143; figures 37, 38 -----	1, 6-16, 19, 20
A	US 2016/100837 A1 (HUANG ZHIFAN F [US] ET AL) 14 April 2016 (2016-04-14) figures 14-15 -----	1-20
A	WO 2012/166499 A1 (ETHICON ENDO SURGERY INC [US]; SPIVEY JAMES T [US]; ORTIZ MARK S [US];) 6 December 2012 (2012-12-06) robot; figures 20, 21 -----	10, 11

## INTERNATIONAL SEARCH REPORT

Information on patent family members

International application No

PCT/IB2018/059839

Patent document cited in search report	Publication date	Patent family member(s)	Publication date	
EP 2157918	A1	03-03-2010	AU 2008251300 A1	20-11-2008
			CA 2691269 A1	20-11-2008
			EP 2157918 A1	03-03-2010
			JP 5331104 B2	30-10-2013
			JP 2010526644 A	05-08-2010
			US 2008294179 A1	27-11-2008
			US 2013306704 A1	21-11-2013
			US 2016262921 A1	15-09-2016
			WO 2008141288 A1	20-11-2008
			-----	
WO 9618344	A2	20-06-1996	AT 274840 T	15-09-2004
			AU 716048 B2	17-02-2000
			CA 2206275 A1	20-06-1996
			CN 1175193 A	04-03-1998
			DE 69533454 D1	07-10-2004
			DE 69533454 T2	01-09-2005
			EP 0918486 A2	02-06-1999
			JP H11506943 A	22-06-1999
			JP 2008142557 A	26-06-2008
			JP 2013051977 A	21-03-2013
			US 5868760 A	09-02-1999
			US 6264086 B1	24-07-2001
			WO 9618344 A2	20-06-1996
			-----	
US 2013153642	A1	20-06-2013	US 2013153622 A1	20-06-2013
			US 2013153623 A1	20-06-2013
			US 2013153624 A1	20-06-2013
			US 2013153642 A1	20-06-2013
-----				
US 2010168768	A1	01-07-2010	US 2008015618 A1	17-01-2008
			US 2010168768 A1	01-07-2010
-----				
EP 1815803	A1	08-08-2007	AT 372726 T	15-09-2007
			AT 509582 T	15-06-2011
			AT 530124 T	15-11-2011
			AT 545371 T	15-03-2012
			AU 771895 B2	08-04-2004
			CA 2378529 A1	28-12-2000
			CA 2556189 A1	28-12-2000
			DE 60036377 T2	12-06-2008
			EP 1187559 A1	20-03-2002
			EP 1447052 A2	18-08-2004
			EP 1658812 A1	24-05-2006
			EP 1815803 A1	08-08-2007
			ES 2290043 T3	16-02-2008
			HK 1112827 A1	09-12-2011
			JP 3842128 B2	08-11-2006
			JP 2003502098 A	21-01-2003
			JP 2004216192 A	05-08-2004
			US 6494888 B1	17-12-2002
			US 2002193816 A1	19-12-2002
			WO 0078227 A1	28-12-2000
-----				
US 2016100837	A1	14-04-2016	BR 112017007647 A2	19-12-2017
			CN 108430341 A	21-08-2018
			EP 3009080 A1	20-04-2016
			JP 2017534420 A	24-11-2017
			PL 3009080 T3	29-06-2018

# INTERNATIONAL SEARCH REPORT

Information on patent family members

International application No

PCT/IB2018/059839

Patent document cited in search report	Publication date	Patent family member(s)	Publication date
		US 2016100837 A1	14-04-2016
		US 2018317917 A1	08-11-2018
		WO 2016060790 A1	21-04-2016
-----			
WO 2012166499	A1 06-12-2012	BR 112013030440 A2	27-09-2016
		CN 103717147 A	09-04-2014
		EP 2713892 A1	09-04-2014
		US 2011295242 A1	01-12-2011
		US 2012199632 A1	09-08-2012
		US 2014291383 A1	02-10-2014
		US 2016192996 A1	07-07-2016
		US 2016192997 A1	07-07-2016
		US 2018132952 A1	17-05-2018
		WO 2012166499 A1	06-12-2012
-----			