

[72] Inventor **Patrick M. Tomaro**
 Maplewood, N.J.
 [21] Appl. No. **49,420**
 [22] Filed **June 24, 1970**
 [45] Patented **June 1, 1971**
 [73] Assignee **Remco Industries, Inc.**
 Harrison, N.J.

[54] **TOY STRUCTURAL SUPPORT SYSTEM AND BUILDING ELEMENTS THEREFORE**
 17 Claims, 14 Drawing Figs.

[52] U.S. Cl. **238/10E,**
 46/1, 46/216, 104/118, 104/125
 [51] Int. Cl. **A63h 19/00,**
 A63h 19/36, A63h 21/04
 [50] Field of Search **238/10 E,**
 10 F, 10 A, 10 B; 104/118—125; 46/1, 216;
 104/148, 60

[56] **References Cited**
UNITED STATES PATENTS
 3,111,910 11/1963 Pao 104/120
 3,115,845 12/1963 Girz 104/148
 3,228,607 1/1966 Robinette et al. 238/10F
 3,252,428 5/1966 Steirkamp 105/147

3,464,624 9/1969 Christiansen 238/10R
 288,194 11/1883 Watson 104/118
 426,877 4/1890 Stream 238/10R
 799,908 9/1905 Humphrey 104/121
 1,482,638 2/1924 Fergusson 238/10(R)
 1,847,733 3/1932 Traver 104/124
 2,534,458 12/1950 Larrabee 238/10R
 2,768,588 10/1956 Robb 104/118
 2,919,515 1/1960 Connell 238/10(E)
 2,943,793 7/1960 Bonanno 238/10(R)
 2,992,598 7/1961 Einfalt 238/10(E)
 3,051,094 8/1962 Shames 104/126

Primary Examiner—Arthur L. La Point
Assistant Examiner—Richard A. Bertsch
Attorney—Bryan, Parmelee, Johnson & Bollinger

ABSTRACT: A toy structural support system is described with beams and stanchions to support the beams and other accessory elements to form a stable three-dimensional toy building structure. The beams are retained in precision alignment and vertically supported by stanchions which are horizontally stabilized by crossmembers. The crossmembers engage the stanchions with complementary fitting grooves and ribs. In a described embodiment the beams are shaped to form a toy three dimensionally arrangeable track for high-speed vehicles.

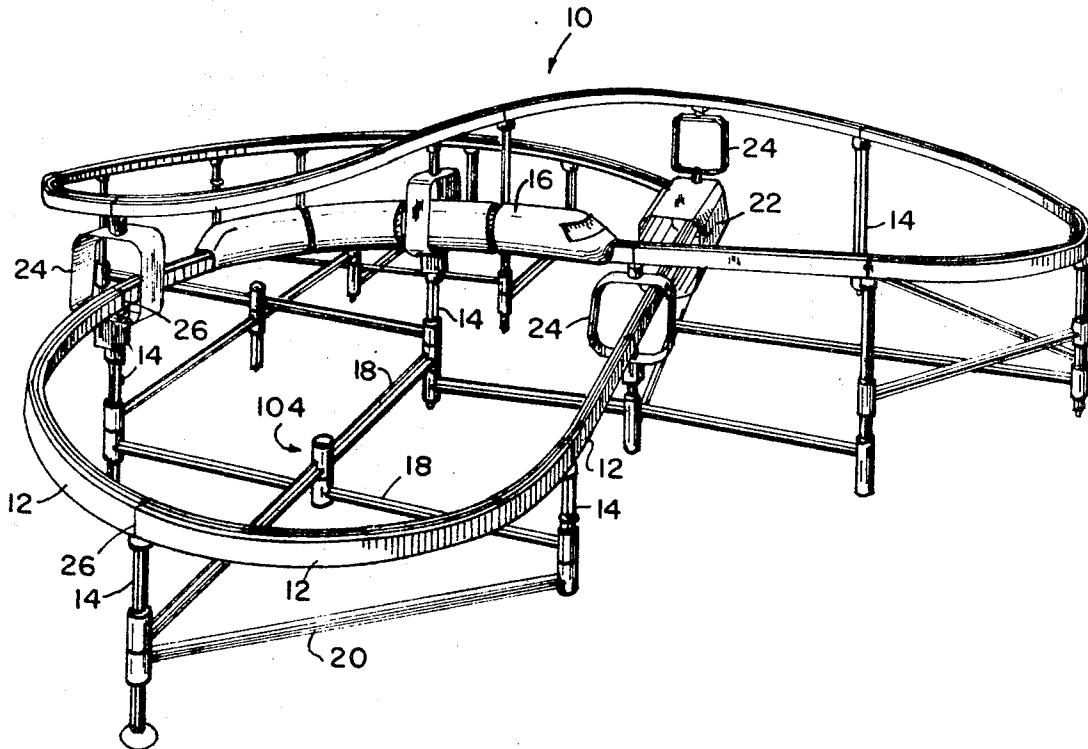

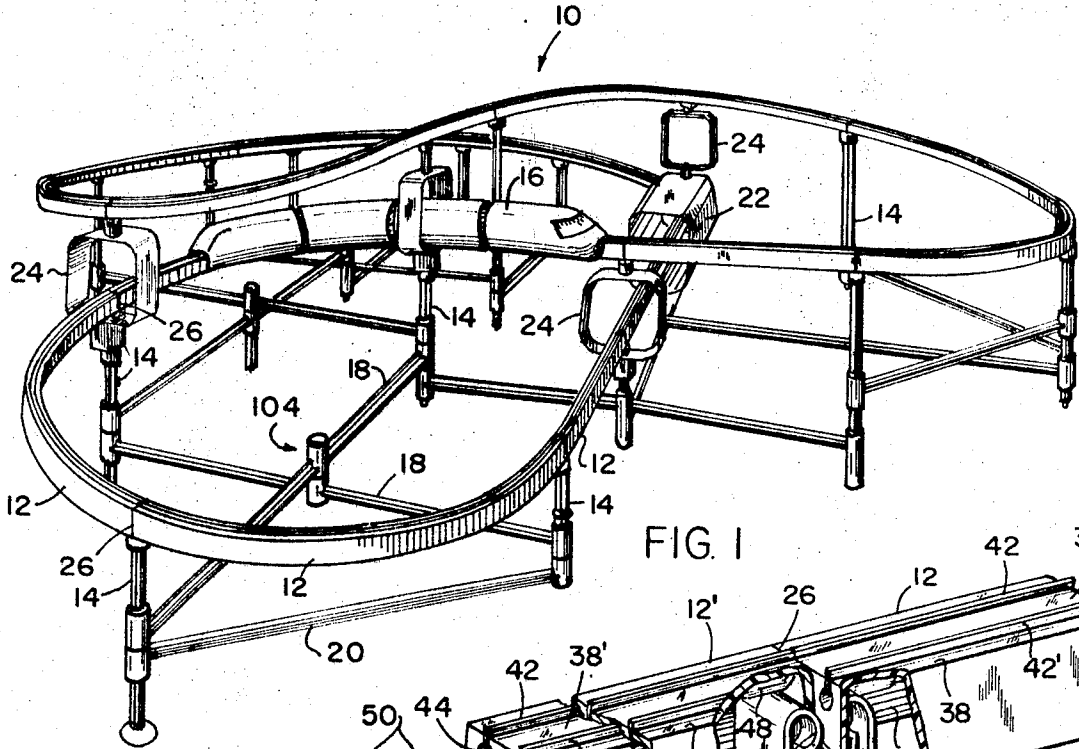

FIG. 1

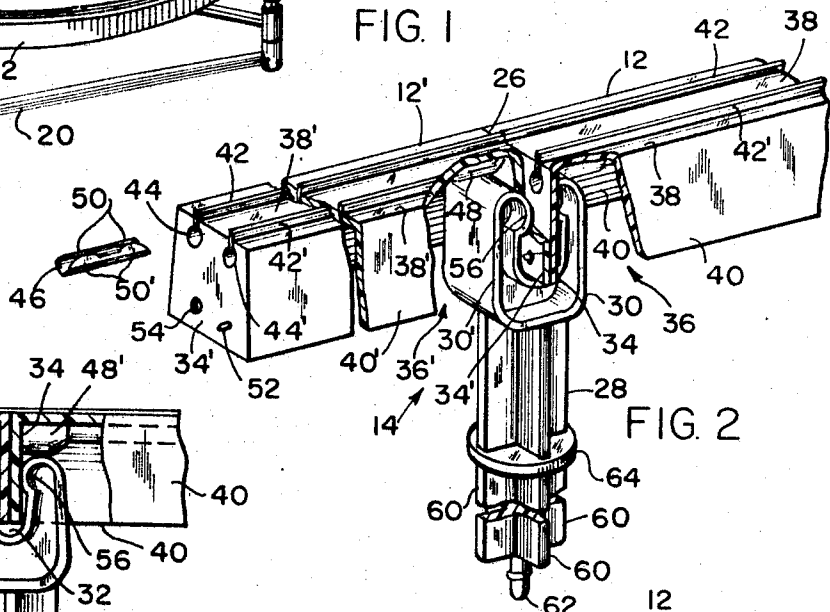

FIG. 2

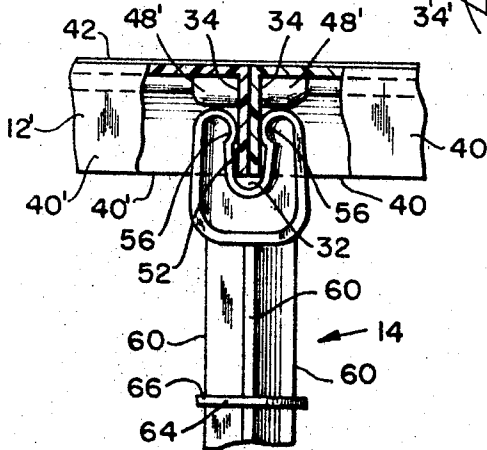

FIG. 3

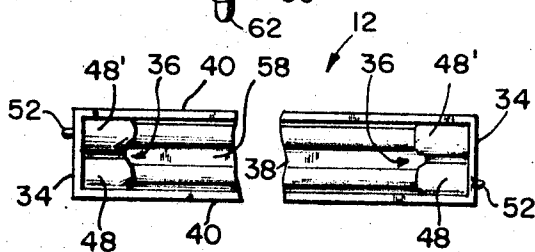

FIG. 4

INVENTOR.
PATRICK M. TOMARO
BY
Bryan, Parmelee,
Johnson & Bollinger.
ATTORNEYS

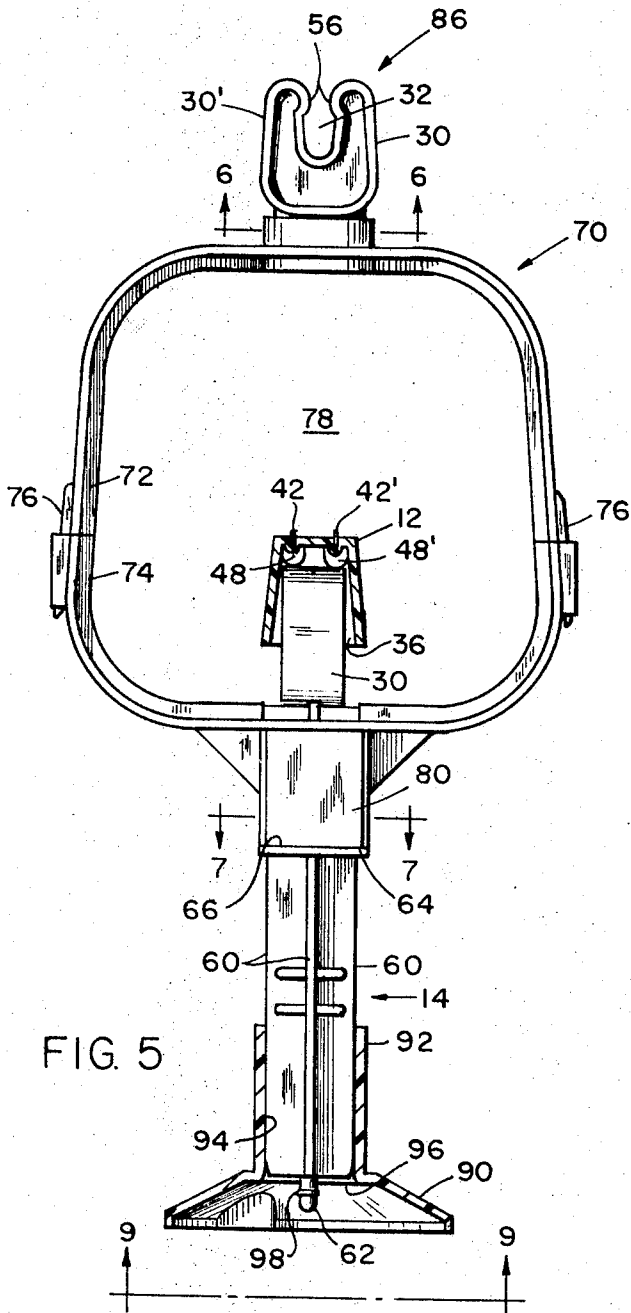

FIG. 5

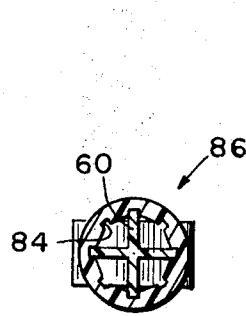

FIG. 6

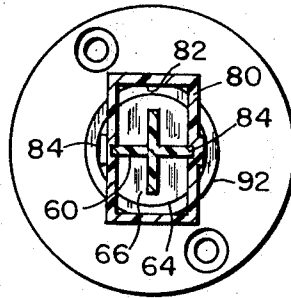

FIG. 7

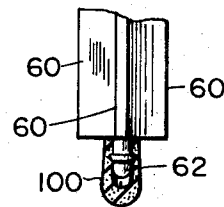

FIG. 8

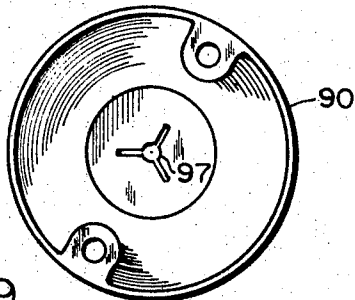

FIG. 9

INVENTOR.
 PATRICK M. TOMARO
 BY
 Bryan, Parmelee,
 Johnson & Bollinger.
 ATTORNEYS

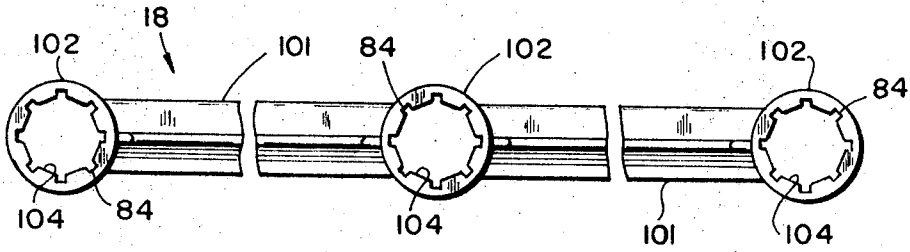

FIG. 10

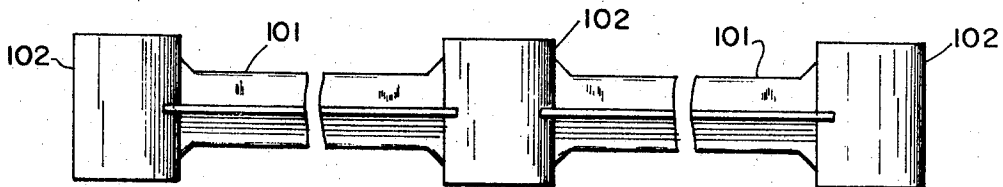

FIG. 11

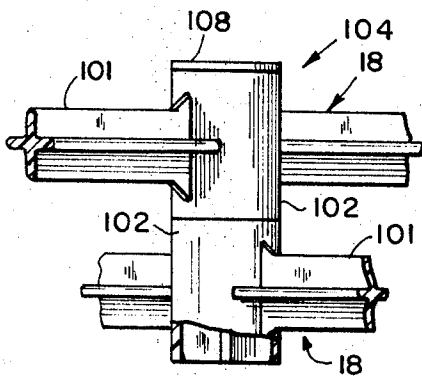

FIG. 13

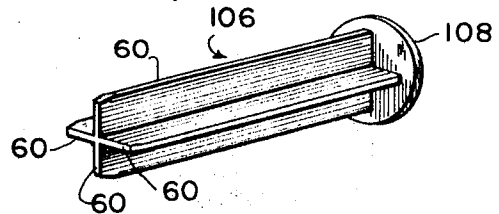

FIG. 12

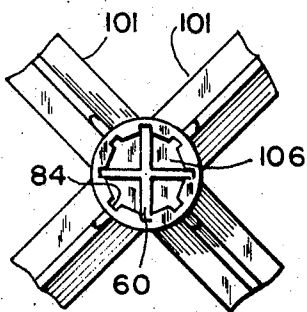

FIG. 14

INVENTOR.
PATRICK M. TOMARO
BY Bryan, Parnelle,
Johnson & Bollinger.
ATTORNEYS

TOY STRUCTURAL SUPPORT SYSTEM AND BUILDING ELEMENTS THEREFORE

SUMMARY OF THE INVENTION

This invention relates to a toy structural support system. More specifically, this invention relates to an elevated toy track which is vertically supported and aligned by stanchions.

In a toy structure in accordance with the invention, beams are provided which are vertically supported by stanchions. The stanchions grip the beams for support across the beam joints and maintain the beams in desired alignment. The vertical stanchions may be horizontally stabilized with crossmembers which engage the stanchions with complementary fitting grooves and ribs. The stanchions are provided with opposing fingers sized to fit in beam recesses to frictionally grip beam walls between them for beam alignment, support and reinforcement against casual release by beam twisting movements.

The toy structure of this invention has been found to be particularly advantageous in providing a three dimensionally arranged elevated vehicle track which may be quickly erected by a child and is sufficiently stable to withstand lateral forces from a high-speed vehicle moving over the track.

In an elevated toy track structure in accordance with the invention the beams are shaped to form track sections supported by stanchions which also maintain the adjoining end walls of track sections in proper alignment to provide a smooth riding surface for vehicles traveling over the elevated track.

The stanchions engage the track sections with upwardly extending fingers. Each stanchion is provided with a pair of opposing fingers which grip the end walls of adjoining track sections between them. The stanchions are quickly installed with the track sections to form an elevated track structure wherein each track joint is both precisely aligned as well as firmly held by the stanchion fingers.

Advantages of the toy structure of this invention reside in its lightweight construction and the ease with which the structure may be assembled by a child. A large variety of complex structure patterns may be formed in three-dimensional configuration.

In a described embodiment in accordance with the invention a variety of track accessory devices are provided which are conveniently supported by the stanchions to form an integral part of an imaginative toy track for enhanced amusement and manipulation by the child.

A track in accordance with this invention is advantageously useful in the form of an electrified track wherein longitudinal conductors are disposed on the track sections and reliably maintained in electrical connection with one another by use of the stanchions.

A further advantage of the toy tracks structure of this invention may be found in a monorail form. The stanchion fingers project upwardly into end-located recesses of the monorail sections wherein the recesses are bounded by rail section end walls and sidewalls. The fingers of the stanchion are sized to fit within the recesses thus allowing sidewalls of the monorail sections to serve as smooth vehicle riding surfaces. The monorail form of a track according to this invention is particularly useful with a toy train track as disclosed in a copending U.S. Pat. application entitled Toy Monorail Train System and filed Jan. 29, 1970 with Ser. No. 6,880 6880 and assigned to the same assignee.

Enhanced stability of the toy structure is obtained with the use of crossmembers that laterally support the various stanchions located below adjoined beams. In a preferred embodiment as will be described, these crossmembers as well as the stanchions are provided with complementary fitting surfaces in the form of ribs and grooves so as to provide precision alignment of crossmembers, stanchions and accessories. In the case of the stanchions, these complementary fitting surfaces are aligned with the fingers of a stanchion so that supported beams have a known orientation with respect to these surfaces. Similar complementary fitting surfaces are located on beam accessory devices and crossmembers and the like.

It is, therefore, an object of the invention to provide an elevated toy structure. It is a further object of the invention to provide an elevated toy track which is easy to erect, of lightweight yet stable construction to enable toy vehicles to traverse the track at high speeds.

DESCRIPTION OF DRAWINGS

Other advantages and objects may be understood from the following description of an embodiment in conjunction with the drawings wherein

FIG. 1 is a perspective view of a monorail elevated toy track structure in accordance with the invention;

FIG. 2 is a broken perspective view of a monorail track joint supported by a stanchion;

FIG. 3 is a broken side view of a monorail track joint supported by a stanchion;

FIG. 4 is a bottom broken view of a straight monorail track section employed in the track system shown in FIG. 1;

FIG. 5 is a view taken along the longitudinal axis of the track of an interconnected track section, stanchion and track accessory device;

FIG. 6 is a section view of a track accessory device mounted section of a stanchion taken along the line 6-6 in FIG. 5;

FIG. 7 is a section view of the stanchion and track accessory device taken along the line 7-7 in FIG. 5;

FIG. 8 is a side view of the bottom end of a stanchion;

FIG. 9 is a bottom view of a pedestal adapted to receive a stanchion and is taken along the line 9-9 in FIG. 5;

FIG. 10 is a top broken view of a crossmember for use with a toy track structure of this invention;

FIG. 11 is a side broken view of the crossmember shown in FIG. 10;

FIG. 12 is a perspective view of an interconnecting member to couple crossmembers to one another in accordance with this invention;

FIG. 13 is a side broken view in elevation of a pair of crossmembers coupled together with a connecting member illustrated in FIG. 12;

FIG. 14 is a bottom view of crossmembers coupled to one another by a connecting member.

DESCRIPTION OF EMBODIMENT

With reference to FIG. 1 an elevated monorail toy track 10 is illustrated in perspective. The specific toy track structure illustrated in FIG. 1 is exemplary of the advantageous variety of uses to which the beam structure of this invention can be applied. The toy track 10 is formed of monorail track sections such as 12 which are elevated with stanchions such as 14 resting upon a platform or floor. The track 10 is of the electrified type supporting a suitably adapted train 16 capable of high-speed travel along the track in a manner such as disclosed in the previously referred to copending application. Crossmembers such as 18-20 are provided to engage the stanchions 14 in an interlocking manner to provide enhanced stability of the toy track 10. Track accessory devices such as a tunnel 22 is provided. Vertical spacers 24 are located at track crossover points for further elevated support of the toy track.

The elevated toy track 10 is elevated by stanchions 14 which engage the monorail sections 12 at the rail joints 26 both to provide vertical support as well as maintain adjoining rail sections in proper alignment.

FIGS. 2 and 3 illustrate the engagement of a stanchion 14 with a pair of monorail track sections 12-12'. The stanchion 14 is formed of an upright extension 28 terminating in a pair of upright opposing fingers 30-30'. The fingers 30-30' are spaced from one another by a gap 32 sized to receive end walls 34-34' of rail sections 12-12'. The rail sections 12-12' are provided with end located recesses 36-36' which are bounded by the rail section upper walls 38-38', the endwalls 34-34' and sidewalls 40-40'. The recesses 36-36' are accessible from below the rail sections 12-12' and the stanchion fingers 30-30' are sized to completely fit in these recesses to smoothly align upper and sidewalls of adjoining rail sections

12-12' with one another to form smooth high-speed riding surfaces for the train 16.

The vertical supporting walls 38-38' are each provided with a pair of imbedded longitudinal strips of conductors 42-42' which project slightly above the surfaces of walls 38-38' for electrical contact with wipers located on the train 16. The conductors 42-42' terminate in the vicinity of end walls 34 in end located connector recesses 44-44' which are oriented longitudinally to receive conductive connectors such as 46. The connector recesses 44-44' are bounded by cylindrically shaped walls 48-48' which project downwardly into the recesses 36-36' of the rail sections 12-12'. As can be seen, the top of the stanchion fingers 30-30' seat against the cylindrical walls 48-48'.

The connector 46 is formed of a thin metal which is bent into a shape to bring its ends opposite one another. The ends are indented to form pairs of opposite spring tabs 50-50'. The connector length is selected so that one set of opposite tabs 50-50' fit in a recess 44 of one rail section and the other set of tabs 50-50' fit in an adjoining and longitudinally aligned recess 44 of an adjoined rail section. The portions of the conductor strips 42 which protrude into the recesses 44 are conductively gripped by the opposite tabs 44. The total length of a connector 46 is slightly less than the combined length of a pair of aligned recesses 44 to fully enclose connector 46 and enable the end walls 34-34' of the rail sections 12-12' to abut each other when gripped by the fingers 30-30' of stanchion 14.

Each of the end walls 34 is further provided with a longitudinally extending protrusion 52 and a protrusion receiving aperture 54. The protrusion of one end wall fits into the aperture of an adjoining end wall so that the rail sections are locked against a twisting movement about their longitudinal axis.

The protrusions 52 are located and sized to slightly project into rail end located recess 36 below bulges 56 of the stanchion mounted fingers 30. In this manner, a stanchion is inserted into the recesses 36 with snap-fit action to avoid a casual upward escape of rail sections 12.

The width of fingers 30 is selected to provide extended lateral gripping of the end walls 34-34' to maintain them in abutment and prevent twisting of the rail sections relative to each other in a horizontal plane.

The bottom view of a rail section 12 in FIG. 4 illustrates the continuity of sidewalls 40 to thus define a channel 58 between end located recesses 36. The rail section is of lightweight construction yet of substantial rigidity.

An advantageous feature of the stanchions 14 resides in the employment of vertically aligned complementary fitting surfaces to interconnect a variety of elements of the track system 10. For instance, the stanchions 14 as shown in FIG. 1 are interconnected with crossmembers such as 18 and 20 for track stability. Track accessory devices such as tunnel 22, are elevated by stanchions 14 with precision alignment relative to the rail sections 12.

Engagement between stanchions and the other track elements is obtained by shaping the lower extension 28 (see FIGS. 2 and 3) with vertical ribs 60 angularly spaced from one another at right angles and terminate at the bottom of the stanchion adjacent a downwardly extending central pin 62. A circular support shoulder 64 is located below the fingers 30 at a predetermined distance and projects with a radial edge 66 beyond the ribs 60.

The ribs are of like size and engage complementary fitting grooves in other track elements. Thus in FIG. 7 a track accessory device in the form of a vertical spacer 70 is shown supported by a stanchion 14. The spacer 70 is formed of a pair of vertically mounted tunnel sections 72-74 which engage each other with a pair of tabs 76 sized to snap fit into slots located in the lower section 74. The tunnel sections 72-74 are shaped to form a passage 78 sized to allow train 16 to pass freely therethrough.

The lower section 74 is provided with a downwardly extending channel section 80 having a rectangular bore 82 (see FIG. 7) which is aligned with the middle of passage 78. Channel 80 is sized to seat on edge 66 of support shoulder 64 of stanchion 14. The channel bore 82 is provided with opposite grooves 84 sized and spaced to freely receive and retain ribs 60 of the stanchion. The grooves 84 are angularly aligned to orient the stanchion fingers 30 and thus rail section 12 as shown in FIG. 5. Hence, with the ribs 60 and grooves 84, the track accessory device, as well as the rail sections passing through it, are maintained in accurate alignment. The stanchion support shoulder 64 provides vertical support of the vertical spacer, the track section 12 as well as other track sections engaged by a stanchion finger section 86 mounted above the upper spacer section 72.

The stanchion finger section 86 is a truncated portion of a stanchion with its ribs 60 engaging grooves 84 in a circular bore 88 in the upper section 72. Note as shown in FIG. 6 how the grooves 84 are distributed at 45° intervals in the bore wall to allow a variety of angular positions of sections 86 and accommodate differently angled crossovers of track sections.

The stanchion 14 as shown in FIG. 5 is mounted in a pedestal 90 formed of an upright cylinder 92 having a bore 94 provided with vertical grooves 84 to receive the ribs 60 of the stanchion 14. The bore 94 terminates at the bottom of the pedestal cylinder 92 in a wall 96 having a central aperture 97 (see FIG. 9) sized slightly smaller than a ring-shaped protrusion 98 on the locating pin 62. The stanchion 14 is snap-fitted to the pedestal 90 by pushing the stanchion pin 62 through the aperture 97 in wall 96.

Alternatively, the stanchion 14 may rest solely on pin 62 or on a resilient cap 100, made of rubber or the like, pushed onto pin 62 as illustrated in FIG. 8.

FIGS. 10 and 11 illustrate a crossmember 18 formed of a rib structure 101 and retainers 102 located at the ends and in the center. Retainers 102 have through bores 104 sized to receive a stanchion 14. Bores 104 are further provided with grooves 84 into which the ribs 60 of the stanchions are located and retained. The retainer grooves 84 are angularly distributed at 45° intervals to correspondingly allow the crossmember 18 to engage the stanchions 14 at corresponding angular positions. Crossmember 20 (see FIG. 1) is constructed in like manner to crossmember 18 except that the centrally located retainer 102 has been deleted.

Crossmembers such as 18 may be connected to one another at a crossover location such as at 104 in FIG. 1 with an interconnecting member 106 (see FIG. 12) having ribs similar to those on a stanchion 14. As shown in FIG. 12, interconnecting member 104 is provided with a stop plate 108 and when mounted to vertically aligned retainers 102 as shown in FIGS. 13 and 14 provides enhanced rigidity and alignment of the track system.

The toy structure of this invention has been described in a specific embodiment directed at an elevated monorail toy track structure. The toy structure advantageously lends itself for general toy building constructions of a variety as great as a child's imagination. The stanchion fingers may be adapted to engage other walls of beams to enhance the variety of construction possibilities. It is to be further understood that the ribs on stanchions and the grooves in accessory devices may be interchanged so that the stanchions, for instance, have grooved cylindrical extensions and the accessory devices are provided with ribs that engage the stanchion grooves.

What I claim is:

1. An elevated toy stanchion supported track for vehicles comprising track sections, each track section having an upwardly facing vehicle support surface, said track sections being provided with downwardly extending end walls shaped to fit adjacent end walls of longitudinally aligned adjoining track sections, said end walls being shaped to be gripped by vertical supporting, track section retaining stanchions, and

5

vertical track support stanchions having at an upper end longitudinally spaced end wall gripping fingers, each of said fingers sized to grip adjoining track end walls between the fingers for track section aligned retention across track joints and vertical track section support whereby a quickly erectable sturdy elevated toy track for vehicles is provided.

2. The elevated toy stanchion supported track for vehicles as claimed in claim 1 wherein said track section end walls are flanked by sidewalls to define downwardly facing end recesses shaped to receive the fingers of the vertical support stanchions.

3. The elevated toy track supported by stanchions as claimed in claim 2 wherein said track section downwardly extending sidewalls extend between opposite end walls of a track section to form a downwardly facing open channel extending longitudinally of the track to form lightweight sturdy track sections.

4. The elevated toy track as claimed in claim 2 wherein the stanchion fingers seat against the bottom of the end recesses to accurately align the vertical support surfaces of adjoining track sections for smooth vehicle travel across track joints.

5. The elevated toy track as claimed in claim 4 wherein the track sections end walls are shaped to fit flush with one another.

6. The elevated toy track as claimed in claim 5 wherein said track sections are made of insulator material and are each provided with pairs of longitudinally aligned laterally spaced conductors imbedded in the vertical support surface for electrification of the track, said track sections each having end located electrical connector recesses in alignment with the conductors which terminate within said recesses, and electrical connectors shaped to fit within said connector recesses to electrically engage aligned conductors in adjoining track sections.

7. The elevated toy track as claimed in claim 1 wherein said stanchion fingers are shaped to contact track section end walls over laterally extended regions for enhanced support against misalignment of track sections in their elevated horizontal plane.

8. The elevated toy track as claimed in claim 7 wherein said fingers on a stanchion face one another across a gap sized to frictionally receive a pair of end walls with an upper region of each of said fingers bulging inwardly towards the gap for finger gripping contact at intermediate locations of end walls located in the gap.

9. The elevated toy track as claimed in claim 8 wherein each of said track section end walls are provided with a protrusion and a protrusion receiving aperture located to complementary fit within a corresponding protrusion and aperture of an adjoining end wall to provide enhanced support of aligned track sections against twisting movements of the track sections about their longitudinal axis.

10. The elevated toy track as claimed in claim 9 wherein said protrusions are sized to project through apertures of adjoining track section between the gaps between stanchion fingers below the finger bulges to provide a snap-fitting of stanchions to the track sections.

11. The elevated toy track as claimed in claim 1 wherein said stanchions are provided with a support shoulder located a predetermined distance below the fingers to vertically support toy track accessory devices.

6

12. The elevated toy track as claimed in claim 11 and further including a toy track accessory device provided with a downwardly open aperture sized to freely receive the fingers of a stanchion for stanchion finger protrusion into the track accessory and with said track accessory aperture further sized to seat the accessory on the stanchion support shoulder whereby track sections inserted into the accessory aperture elevatingly support the track accessory device and track sections operatively located with respect to said track accessory device.

13. The elevated toy track as claimed in claim 12 wherein said stanchions and track accessory device aperture are provided with vertical complementary fitting elements in the form of ribs and grooves with predetermined horizontal orientation to accurately align the track section and accessory device relative to one another.

14. The elevated toy track as claimed in claim 12 and further including crossmembers provided with end located stanchion engaging retainers having complementary fitting elements, said crossmembers being sized to engage with their retainers the respective stanchions for enhanced track stability.

15. An elevated toy monorail track for monorail vehicles and the like supported by stanchions comprising monorail rail sections, each rail section being provided with an upper vehicle support surface and downwardly extending end walls and smooth longitudinal sidewalls, said monorail sections having downwardly facing end recesses bounded by the sidewalls and the end walls,

vertical rail section supporting stanchions having at their upper ends longitudinally spaced end wall gripping fingers, each of said fingers being sized to project into the end recesses between the sidewalls of the rail sections and grip between the fingers the adjoining end walls of longitudinally aligned rail sections, said stanchion fingers being spaced to retain rail joints in alignment and vertically support adjoining rail sections and form a quickly erectable sturdy elevated toy monorail track.

16. A toy train track system capable of stably supporting a train traveling at high speed over elevated track comprising a monorail track formed of an electrically nonconductive material and having smooth lateral support surfaces and provided with a pair of parallel spaced longitudinally aligned conductors for transmitting electrical power to a train located on the track, said track being formed of longitudinally aligned open channel segments, with each segment operatively mounted with the open ends of the channel segments facing downwardly to form aligned upper and side located train supporting surfaces with other aligned track segments and

track supporting stanchions sized and located to engage the track and elevate selected track portions to form a track with vertically slanted ramps, said stanchions being provided with upwardly extending track channel engaging members which supportively engage the open track channels to elevate the track.

17. The toy train track system as claimed in claim 16 wherein the track supporting stanchions are provided with upwardly extending track channel engaging wedging members sized to frictionally grip the open track channels for elevation of the track.

65

70

75