

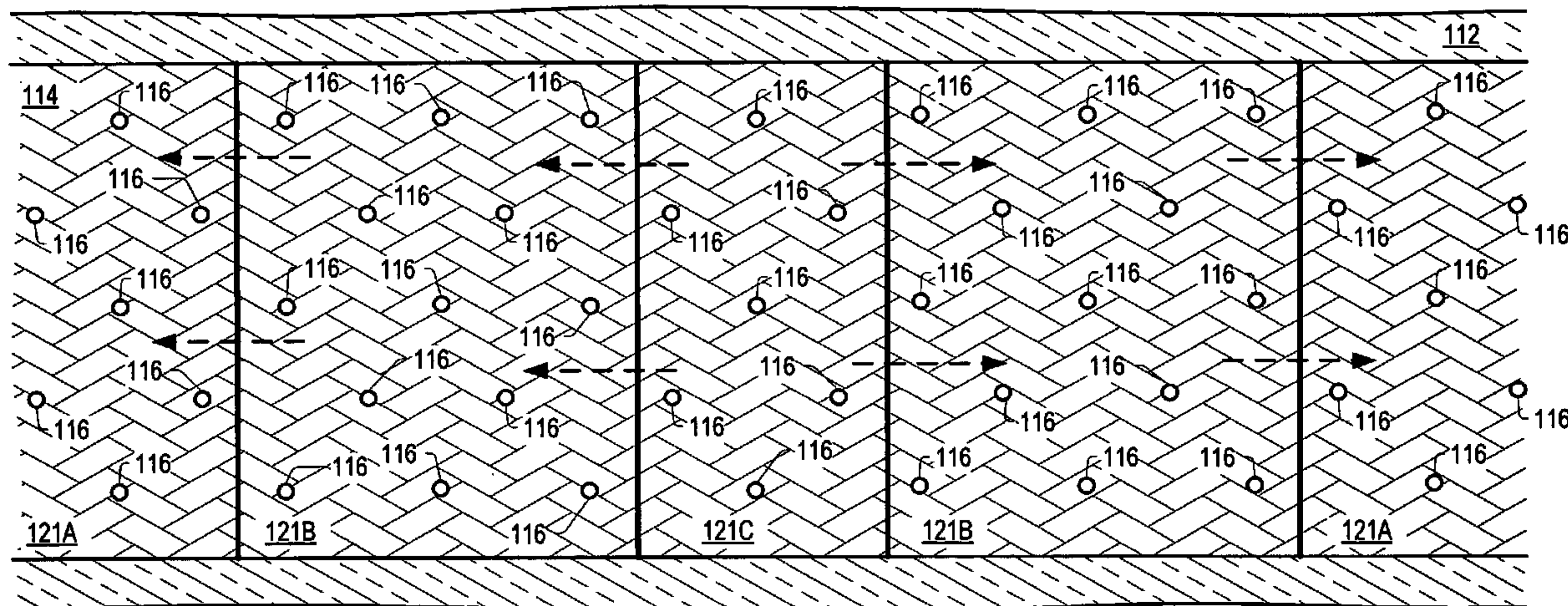

(86) Date de dépôt PCT/PCT Filing Date: 2007/10/19
 (87) Date publication PCT/PCT Publication Date: 2008/05/02
 (85) Entrée phase nationale/National Entry: 2009/04/17
 (86) N° demande PCT/PCT Application No.: US 2007/081904
 (87) N° publication PCT/PCT Publication No.: 2008/051830
 (30) Priorités/Priorities: 2006/10/20 (US60/853,096);
 2007/04/20 (US60/925,685)

(51) Cl.Int./Int.Cl. *E21B 43/24* (2006.01),
E21B 36/00 (2006.01), *E21B 43/14* (2006.01),
E21B 43/241 (2006.01), *E21B 43/30* (2006.01)
 (71) Demandeur/Applicant:
 SHELL INTERNATIONALE RESEARCH
 MAATSCHAPPIJ B.V., NL
 (72) Inventeurs/Inventors:
 JAISWAL, NAMIT, US;
 KARANIKAS, JOHN MICHAEL, US;
 MO, WEIJAN, US;
 MUDUNURI, RAMESH RAJU, US;
 STEGEMEIER, GEORGE LEO, US;
 VINEGAR, HAROLD J., US
 (74) Agent: SMART & BIGGAR

(54) Titre : DEPLACEMENT D'HYDROCARBURES A TRAVERS DES PARTIES DE FORMATIONS DE SABLES
 BITUMINEUX AVEC UN FLUIDE
 (54) Title: MOVING HYDROCARBONS THROUGH PORTIONS OF TAR SANDS FORMATIONS WITH A FLUID



(57) **Abrégé/Abstract:**

A method for treating a tar sands formation is disclosed. The method includes heating a first portion of a hydrocarbon layer in the formation from one or more heaters located in the first portion. The heat is controlled to increase a fluid injectivity of the first portion. A drive fluid and/or an oxidizing fluid is injected and/or created in the first portion to cause at least some hydrocarbons to move from a second portion of the hydrocarbon layer to a third portion of the hydrocarbon layer. The second portion is between the first portion and the third portion. The first, second, and third portions are horizontally displaced from each other. The third portion is heated from one or more heaters located in the third portion. Hydrocarbons are produced from the third portion of the formation. The hydrocarbons include at least some hydrocarbons from the second portion of the formation.

(12) INTERNATIONAL APPLICATION PUBLISHED UNDER THE PATENT COOPERATION TREATY (PCT)

(19) World Intellectual Property Organization
International Bureau



(43) International Publication Date
2 May 2008 (02.05.2008)

PCT

(10) International Publication Number
WO 2008/051830 A3

(51) International Patent Classification:

E21B 36/00 (2006.01) *E21B 43/241* (2006.01)
E21B 43/00 (2006.01) *E21B 36/04* (2006.01)

(21) International Application Number:

PCT/US2007/081904

(22) International Filing Date: 19 October 2007 (19.10.2007)

(25) Filing Language: English

(26) Publication Language: English

(30) Priority Data:

60/853,096 20 October 2006 (20.10.2006) US
60/925,685 20 April 2007 (20.04.2007) US

(71) Applicant (for SM only): **SHELL OIL COMPANY**
[US/US]; One Shell Plaza, P.O. Box 2463, Houston, Texas
77252-2463 (US).

(71) Applicant (for all designated States except US): **SHELL
INTERNATIONALE RESEARCH MAATSCHAPPIJ
B.V.** [NL/NL]; Carel van Bylandtlaan 30, NL-2596 HR The
Hague (NL).

(72) Inventors; and

(75) Inventors/Applicants (for US only): **JAISWAL, Namit**
[IN/US]; 15135 Memorial Drive, Apt. 3207, Hous-
ton, Texas 77079 (US). **KARANIKAS, John Michael**
[US/US]; 4655 Wild Indigo Street, Apt.302, Houston,
Texas 77027 (US). **MO, Weijan** [US/US]; 719 Winston
Lane, Sugar Land, Texas 77479 (US). **MUDUNURI,
Ramesh Raju** [IN/US]; 8181 Fannin Street, Apt. 2026,

Houston, Texas 77054 (US). **STEGEMEIER, George
Leo** [US/US]; 5819 Queensloch Drive, Houston, Texas
77096 (US). **VINEGAR, Harold J.** [US/US]; 4613 Lau-
rel, Bellaire, Bellaire, Texas 77401 (US).

(74) Agent: **CHRISTENSEN, Del S.**; Shell Oil Company, One
Shell Plaza, P.O. Box 2463, Houston, Texas 77252-2463
(US).

(81) Designated States (unless otherwise indicated, for every
kind of national protection available): AE, AG, AL, AM,
AT, AU, AZ, BA, BB, BG, BH, BR, BW, BY, BZ, CA, CH,
CN, CO, CR, CU, CZ, DE, DK, DM, DO, DZ, EC, EE, EG,
ES, FI, GB, GD, GE, GH, GM, GT, HN, HR, HU, ID, IL,
IN, IS, JP, KE, KG, KM, KN, KP, KR, KZ, LA, LC, LK,
LR, LS, LT, LU, LY, MA, MD, ME, MG, MK, MN, MW,
MX, MY, MZ, NA, NG, NI, NO, NZ, OM, PG, PH, PL,
PT, RO, RS, RU, SC, SD, SE, SG, SK, SL, SM, SV, SY,
TJ, TM, TN, TR, TT, TZ, UA, UG, US, UZ, VC, VN, ZA,
ZM, ZW.

(84) Designated States (unless otherwise indicated, for every
kind of regional protection available): ARIPO (BW, GH,
GM, KE, LS, MW, MZ, NA, SD, SL, SZ, TZ, UG, ZM,
ZW), Eurasian (AM, AZ, BY, KG, KZ, MD, RU, TJ, TM),
European (AT, BE, BG, CH, CY, CZ, DE, DK, EE, ES, FI,
FR, GB, GR, HU, IE, IS, IT, LT, LU, LV, MC, MT, NL, PL,
PT, RO, SE, SI, SK, TR), OAPI (BF, BJ, CF, CG, CI, CM,
GA, GN, GQ, GW, ML, MR, NE, SN, TD, TG).

Published:

— with international search report

(88) Date of publication of the international search report:
30 April 2009

(54) Title: MOVING HYDROCARBONS THROUGH PORTIONS OF TAR SANDS FORMATIONS WITH A FLUID

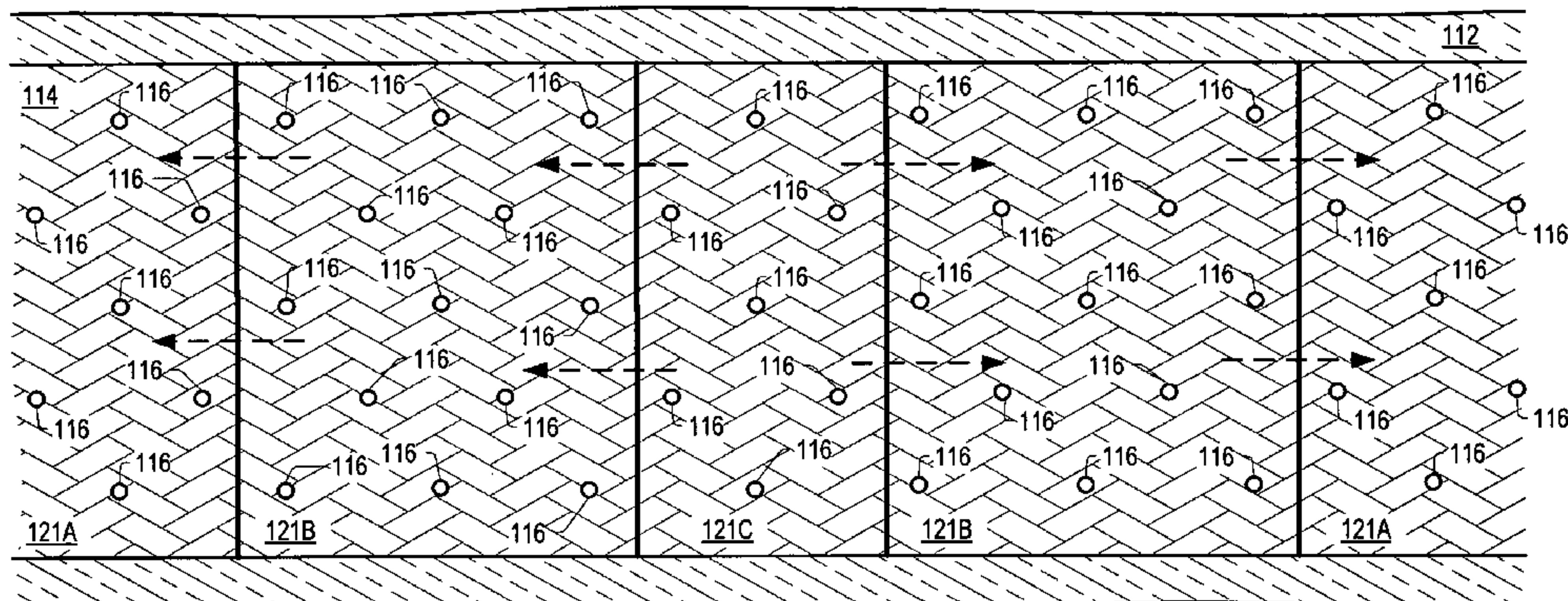

(57) Abstract: A method for treating a tar sands formation is disclosed. The method includes heating a first portion of a hydrocarbon layer in the formation from one or more heaters located in the first portion. The heat is controlled to increase a fluid injectivity of the first portion. A drive fluid and/or an oxidizing fluid is injected and/or created in the first portion to cause at least some hydrocarbons to move from a second portion of the hydrocarbon layer to a third portion of the hydrocarbon layer. The second portion is between the first portion and the third portion. The first, second, and third portions are horizontally displaced from each other. The third portion is heated from one or more heaters located in the third portion. Hydrocarbons are produced from the third portion of the formation. The hydrocarbons include at least some hydrocarbons from the second portion of the formation.

WO 2008/051830 A3

**MOVING HYDROCARBONS THROUGH PORTIONS OF TAR SANDS
FORMATIONS WITH A FLUID**

BACKGROUND

5 1. Field of the Invention

[0001] The present invention relates generally to methods and systems for production of hydrocarbons, hydrogen, and/or other products from various subsurface formations such as hydrocarbon containing formations (for example, tar sands formations).

10 2. Description of Related Art

[0002] Hydrocarbons obtained from subterranean formations are often used as energy resources, as feedstocks, and as consumer products. Concerns over depletion of available hydrocarbon resources and concerns over declining overall quality of produced hydrocarbons have led to development of processes for more efficient recovery, processing and/or use of available hydrocarbon resources. In situ processes may be used to remove hydrocarbon materials from subterranean formations. Chemical and/or physical properties of hydrocarbon material in a subterranean formation may need to be changed to allow hydrocarbon material to be more easily removed from the subterranean formation. The chemical and physical changes may include in situ reactions that produce removable fluids, composition changes, solubility changes, density changes, phase changes, and/or viscosity changes of the hydrocarbon material in the formation. A fluid may be, but is not limited to, a gas, a liquid, an emulsion, a slurry, and/or a stream of solid particles that has flow characteristics similar to liquid flow.

[0003] Large deposits of heavy hydrocarbons (heavy oil and/or tar) contained in relatively permeable formations (for example in tar sands) are found in North America, South America, Africa, and Asia. Tar can be surface-mined and upgraded to lighter hydrocarbons such as crude oil, naphtha, kerosene, and/or gas oil. Surface milling processes may further separate the bitumen from sand. The separated bitumen may be converted to light hydrocarbons using conventional refinery methods. Mining and upgrading tar sand is usually substantially more expensive than producing lighter hydrocarbons from conventional oil reservoirs.

[0004] In situ production of hydrocarbons from tar sand may be accomplished by heating and/or injecting a gas into the formation. U.S. Patent Nos. 5,211,230 to Ostapovich et al.

and 5,339,897 to Leaute describe a horizontal production well located in an oil-bearing reservoir. A vertical conduit may be used to inject an oxidant gas into the reservoir for in situ combustion.

[0005] U.S. Patent No. 2,780,450 to Ljungstrom describes heating bituminous geological formations in situ to convert or crack a liquid tar-like substance into oils and gases.

[0006] U.S. Patent No. 4,597,441 to Ware et al. describes contacting oil, heat, and hydrogen simultaneously in a reservoir. Hydrogenation may enhance recovery of oil from the reservoir.

[0007] U.S. Patent No. 5,046,559 to Glandt and 5,060,726 to Glandt et al. describe preheating a portion of a tar sand formation between an injector well and a producer well. Steam may be injected from the injector well into the formation to produce hydrocarbons at the producer well.

[0008] As outlined above, there has been a significant amount of effort to develop methods and systems to economically produce hydrocarbons, hydrogen, and/or other products from hydrocarbon containing formations. At present, however, there are still many hydrocarbon containing formations from which hydrocarbons, hydrogen, and/or other products cannot be economically produced. Thus, there is still a need for improved methods and systems for production of hydrocarbons, hydrogen, and/or other products from various hydrocarbon containing formations.

20

SUMMARY

[0009] Embodiments described herein generally relate to systems, methods, and heaters for treating a subsurface formation. Embodiments described herein also generally relate to heaters that have novel components therein. Such heaters can be obtained by using the systems and methods described herein.

[0010] In certain embodiments, the invention provides one or more systems, methods, and/or heaters. In some embodiments, the systems, methods, and/or heaters are used for treating a subsurface formation.

[0011] In some embodiments, the invention provides a method for treating a tar sands formation, comprising: heating a first portion of a hydrocarbon layer in the formation from one or more heaters located in the first portion; controlling the heating to increase a fluid injectivity of the first portion; injecting and/or creating a drive fluid and/or an oxidizing fluid in the first portion to cause at least some hydrocarbons to move from a second portion of the hydrocarbon layer to a third portion of the hydrocarbon layer, the second portion

being between the first portion and the third portion, and the first, second, and third portions being horizontally displaced from each other; heating the third portion from one or more heaters located in the third portion; and producing hydrocarbons from the third portion of the formation, the hydrocarbons including at least some hydrocarbons from the second portion of the formation.

[0012] In further embodiments, features from specific embodiments may be combined with features from other embodiments. For example, features from one embodiment may be combined with features from any of the other embodiments.

[0013] In further embodiments, treating a subsurface formation is performed using any of the methods, systems, or heaters described herein.

[0014] In further embodiments, additional features may be added to the specific embodiments described herein.

BRIEF DESCRIPTION OF THE DRAWINGS

[0015] Advantages of the present invention may become apparent to those skilled in the art with the benefit of the following detailed description and upon reference to the accompanying drawings in which:

[0016] FIG. 1 depicts an illustration of stages of heating a hydrocarbon containing formation.

[0017] FIG. 2 shows a schematic view of an embodiment of a portion of an in situ heat treatment system for treating a hydrocarbon containing formation.

[0018] FIG. 3 depicts a side view representation of an embodiment for producing mobilized fluids from a tar sands formation with a relatively thin hydrocarbon layer.

[0019] FIG. 4 depicts a side view representation of an embodiment for producing mobilized fluids from a tar sands formation with a hydrocarbon layer that is thicker than the hydrocarbon layer depicted in FIG. 3.

[0020] FIG. 5 depicts a side view representation of an embodiment for producing mobilized fluids from a tar sands formation with a hydrocarbon layer that is thicker than the hydrocarbon layer depicted in FIG. 4.

[0021] FIG. 6 depicts a side view representation of an embodiment for producing mobilized fluids from a tar sands formation with a hydrocarbon layer that has a shale break.

[0022] FIG. 7 depicts a top view representation of an embodiment for preheating using heaters for the drive process.

- [0023] FIG. 8 depicts a side view representation of an embodiment using at least three treatment sections in a tar sands formation.
- [0024] FIG. 9 depicts a side view representation of an embodiment for preheating using heaters for the drive process.
- 5 [0025] FIG. 10 depicts a temperature profile in the formation after 360 days using the STARS simulation.
- [0026] FIG. 11 depicts an oil saturation profile in the formation after 360 days using the STARS simulation.
- [0027] FIG. 12 depicts the oil saturation profile in the formation after 1095 days using the
10 STARS simulation.
- [0028] FIG. 13 depicts the oil saturation profile in the formation after 1470 days using the STARS simulation.
- [0029] FIG. 14 depicts the oil saturation profile in the formation after 1826 days using the STARS simulation.
- 15 [0030] FIG. 15 depicts the temperature profile in the formation after 1826 days using the STARS simulation.
- [0031] FIG. 16 depicts oil production rate and gas production rate versus time.
- [0032] FIG. 17 depicts weight percentage of original bitumen in place (OBIP)(left axis) and volume percentage of OBIP (right axis) versus temperature ($^{\circ}\text{C}$).
- 20 [0033] FIG. 18 depicts bitumen conversion percentage (weight percentage of (OBIP))(left axis) and oil, gas, and coke weight percentage (as a weight percentage of OBIP)(right axis) versus temperature ($^{\circ}\text{C}$).
- [0034] FIG. 19 depicts API gravity ($^{\circ}$)(left axis) of produced fluids, blow down production, and oil left in place along with pressure (psig)(right axis) versus temperature
25 ($^{\circ}\text{C}$).
- [0035] FIG. 20A-D depict gas-to-oil ratios (GOR) in thousand cubic feet per barrel ((Mcf/bbl)(y-axis) versus temperature ($^{\circ}\text{C}$)(x-axis) for different types of gas at a low temperature blow down (about 277°C) and a high temperature blow down (at about 290°C).
- [0036] FIG. 21 depicts coke yield (weight percentage)(y-axis) versus temperature ($^{\circ}\text{C}$)(x-
30 axis).
- [0037] FIG. 22A-D depict assessed hydrocarbon isomer shifts in fluids produced from the experimental cells as a function of temperature and bitumen conversion.

[0038] FIG. 23 depicts weight percentage (Wt%)(y-axis) of saturates from SARA analysis of the produced fluids versus temperature (°C)(x-axis).

[0039] FIG. 24 depicts weight percentage (Wt%)(y-axis) of n-C₇ of the produced fluids versus temperature (°C)(x-axis).

5 [0040] FIG. 25 depicts oil recovery (volume percentage bitumen in place (vol% BIP)) versus API gravity (°) as determined by the pressure (MPa) in the formation in an experiment.

[0041] FIG. 26 depicts recovery efficiency (%) versus temperature (°C) at different pressures in an experiment.

10 [0042] While the invention is susceptible to various modifications and alternative forms, specific embodiments thereof are shown by way of example in the drawings and may herein be described in detail. The drawings may not be to scale. It should be understood, however, that the drawings and detailed description thereto are not intended to limit the invention to the particular form disclosed, but on the contrary, the intention is to cover all
15 modifications, equivalents and alternatives of the present invention as defined by the appended claims.

DETAILED DESCRIPTION

[0043] The following description generally relates to systems and methods for treating hydrocarbons in the formations. Such formations may be treated to yield hydrocarbon
20 products, hydrogen, and other products.

[0044] “API gravity” refers to API gravity at 15.5 °C (60 °F). API gravity is as determined by ASTM Method D6822 or ASTM Method D1298.

[0045] “Bromine number” refers to a weight percentage of olefins in grams per 100 gram of portion of the produced fluid that has a boiling range below 246 °C and testing the
25 portion using ASTM Method D1159.

[0046] “Cracking” refers to a process involving decomposition and molecular recombination of organic compounds to produce a greater number of molecules than were initially present. In cracking, a series of reactions take place accompanied by a transfer of hydrogen atoms between molecules. For example, naphtha may undergo a thermal
30 cracking reaction to form ethene and H₂.

[0047] “Fluid pressure” is a pressure generated by a fluid in a formation. “Lithostatic pressure” (sometimes referred to as “lithostatic stress”) is a pressure in a formation equal to

a weight per unit area of an overlying rock mass. "Hydrostatic pressure" is a pressure in a formation exerted by a column of water.

[0048] A "formation" includes one or more hydrocarbon containing layers, one or more non-hydrocarbon layers, an overburden, and/or an underburden. "Hydrocarbon layers" refer to layers in the formation that contain hydrocarbons. The hydrocarbon layers may contain non-hydrocarbon material and hydrocarbon material. The "overburden" and/or the "underburden" include one or more different types of impermeable materials. For example, the overburden and/or underburden may include rock, shale, mudstone, or wet/tight carbonate. In some embodiments of in situ heat treatment processes, the overburden and/or the underburden may include a hydrocarbon containing layer or hydrocarbon containing layers that are relatively impermeable and are not subjected to temperatures during in situ heat treatment processing that result in significant characteristic changes of the hydrocarbon containing layers of the overburden and/or the underburden. For example, the underburden may contain shale or mudstone, but the underburden is not allowed to heat to pyrolysis temperatures during the in situ heat treatment process. In some cases, the overburden and/or the underburden may be somewhat permeable.

[0049] "Formation fluids" refer to fluids present in a formation and may include pyrolyzation fluid, synthesis gas, mobilized hydrocarbon, and water (steam). Formation fluids may include hydrocarbon fluids as well as non-hydrocarbon fluids. The term "mobilized fluid" refers to fluids in a hydrocarbon containing formation that are able to flow as a result of thermal treatment of the formation. "Produced fluids" refer to fluids removed from the formation.

[0050] A "heat source" is any system for providing heat to at least a portion of a formation substantially by conductive and/or radiative heat transfer. For example, a heat source may include electric heaters such as an insulated conductor, an elongated member, and/or a conductor disposed in a conduit. A heat source may also include systems that generate heat by burning a fuel external to or in a formation. The systems may be surface burners, downhole gas burners, flameless distributed combustors, and natural distributed combustors. In some embodiments, heat provided to or generated in one or more heat sources may be supplied by other sources of energy. The other sources of energy may directly heat a formation, or the energy may be applied to a transfer medium that directly or indirectly heats the formation. It is to be understood that one or more heat sources that are applying heat to a formation may use different sources of energy. Thus, for example,

for a given formation some heat sources may supply heat from electric resistance heaters, some heat sources may provide heat from combustion, and some heat sources may provide heat from one or more other energy sources (for example, chemical reactions, solar energy, wind energy, biomass, or other sources of renewable energy). A chemical reaction may include an exothermic reaction (for example, an oxidation reaction). A heat source may also include a heater that provides heat to a zone proximate and/or surrounding a heating location such as a heater well.

[0051] A “heater” is any system or heat source for generating heat in a well or a near wellbore region. Heaters may be, but are not limited to, electric heaters, burners, combustors that react with material in or produced from a formation, and/or combinations thereof.

[0052] “Heavy hydrocarbons” are viscous hydrocarbon fluids. Heavy hydrocarbons may include highly viscous hydrocarbon fluids such as heavy oil, tar, and/or asphalt. Heavy hydrocarbons may include carbon and hydrogen, as well as smaller concentrations of sulfur, oxygen, and nitrogen. Additional elements may also be present in heavy hydrocarbons in trace amounts. Heavy hydrocarbons may be classified by API gravity. Heavy hydrocarbons generally have an API gravity below about 20°. Heavy oil, for example, generally has an API gravity of about 10-20°, whereas tar generally has an API gravity below about 10°. The viscosity of heavy hydrocarbons is generally greater than about 100 centipoise at 15 °C. Heavy hydrocarbons may include aromatics or other complex ring hydrocarbons.

[0053] Heavy hydrocarbons may be found in a relatively permeable formation. The relatively permeable formation may include heavy hydrocarbons entrained in, for example, sand or carbonate. “Relatively permeable” is defined, with respect to formations or portions thereof, as an average permeability of 10 millidarcy or more (for example, 10 or 100 millidarcy). “Relatively low permeability” is defined, with respect to formations or portions thereof, as an average permeability of less than about 10 millidarcy. One darcy is equal to about 0.99 square micrometers. An impermeable layer generally has a permeability of less than about 0.1 millidarcy.

[0054] Certain types of formations that include heavy hydrocarbons may also include, but are not limited to, natural mineral waxes, or natural asphaltites. “Natural mineral waxes” typically occur in substantially tubular veins that may be several meters wide, several kilometers long, and hundreds of meters deep. “Natural asphaltites” include solid

hydrocarbons of an aromatic composition and typically occur in large veins. In situ recovery of hydrocarbons from formations such as natural mineral waxes and natural asphaltites may include melting to form liquid hydrocarbons and/or solution mining of hydrocarbons from the formations.

- 5 [0055] “Hydrocarbons” are generally defined as molecules formed primarily by carbon and hydrogen atoms. Hydrocarbons may also include other elements such as, but not limited to, halogens, metallic elements, nitrogen, oxygen, and/or sulfur. Hydrocarbons may be, but are not limited to, kerogen, bitumen, pyrobitumen, oils, natural mineral waxes, and asphaltites. Hydrocarbons may be located in or adjacent to mineral matrices in the earth.
- 10 Matrices may include, but are not limited to, sedimentary rock, sands, silicilytes, carbonates, diatomites, and other porous media. “Hydrocarbon fluids” are fluids that include hydrocarbons. Hydrocarbon fluids may include, entrain, or be entrained in non-hydrocarbon fluids such as hydrogen, nitrogen, carbon monoxide, carbon dioxide, hydrogen sulfide, water, and ammonia.
- 15 [0056] An “in situ conversion process” refers to a process of heating a hydrocarbon containing formation from heat sources to raise the temperature of at least a portion of the formation above a pyrolysis temperature so that pyrolyzation fluid is produced in the formation.
- [0057] An “in situ heat treatment process” refers to a process of heating a hydrocarbon
20 containing formation with heat sources to raise the temperature of at least a portion of the formation above a temperature that results in mobilized fluid, visbreaking, and/or pyrolysis of hydrocarbon containing material so that mobilized fluids, visbroken fluids, and/or pyrolyzation fluids are produced in the formation.
- [0058] “Karst” is a subsurface shaped by the dissolution of a soluble layer or layers of
25 bedrock, usually carbonate rock such as limestone or dolomite. The dissolution may be caused by meteoric or acidic water. The Grosmont formation in Alberta, Canada is an example of a karst (or “karsted”) carbonate formation.
- [0059] “P (peptization) value” or “P-value” refers to a numerical value, which represents the flocculation tendency of asphaltenes in a formation fluid. P-value is determined by
30 ASTM method D7060.
- [0060] “Pyrolysis” is the breaking of chemical bonds due to the application of heat. For example, pyrolysis may include transforming a compound into one or more other

substances by heat alone. Heat may be transferred to a section of the formation to cause pyrolysis.

[0061] "Superposition of heat" refers to providing heat from two or more heat sources to a selected section of a formation such that the temperature of the formation at least at one
5 location between the heat sources is influenced by the heat sources.

[0062] "Tar" is a viscous hydrocarbon that generally has a viscosity greater than about 10,000 centipoise at 15 °C. The specific gravity of tar generally is greater than 1.000. Tar may have an API gravity less than 10°.

[0063] A "tar sands formation" is a formation in which hydrocarbons are predominantly
10 present in the form of heavy hydrocarbons and/or tar entrained in a mineral grain framework or other host lithology (for example, sand or carbonate). Examples of tar sands formations include formations such as the Athabasca formation, the Grosmont formation, and the Peace River formation, all three in Alberta, Canada; and the Faja formation in the Orinoco belt in Venezuela.

[0064] "Temperature limited heater" generally refers to a heater that regulates heat output
15 (for example, reduces heat output) above a specified temperature without the use of external controls such as temperature controllers, power regulators, rectifiers, or other devices. Temperature limited heaters may be AC (alternating current) or modulated (for example, "chopped") DC (direct current) powered electrical resistance heaters.

[0065] "Thickness" of a layer refers to the thickness of a cross section of the layer, wherein
20 the cross section is normal to a face of the layer.

[0066] A "u-shaped wellbore" refers to a wellbore that extends from a first opening in the formation, through at least a portion of the formation, and out through a second opening in the formation. In this context, the wellbore may be only roughly in the shape of a "v" or
25 "u", with the understanding that the "legs" of the "u" do not need to be parallel to each other, or perpendicular to the "bottom" of the "u" for the wellbore to be considered "u-shaped".

[0067] "Upgrade" refers to increasing the quality of hydrocarbons. For example, upgrading heavy hydrocarbons may result in an increase in the API gravity of the heavy
30 hydrocarbons.

[0068] "Visbreaking" refers to the untangling of molecules in fluid during heat treatment and/or to the breaking of large molecules into smaller molecules during heat treatment, which results in a reduction of the viscosity of the fluid.

[0069] "Viscosity" refers to kinematic viscosity at 40 °C unless specified. Viscosity is as determined by ASTM Method D445.

[0070] A "vug" is a cavity, void or large pore in a rock that is commonly lined with mineral precipitates.

5 [0071] The term "wellbore" refers to a hole in a formation made by drilling or insertion of a conduit into the formation. A wellbore may have a substantially circular cross section, or another cross-sectional shape. As used herein, the terms "well" and "opening," when referring to an opening in the formation may be used interchangeably with the term "wellbore."

10 [0072] Hydrocarbons in formations may be treated in various ways to produce many different products. In certain embodiments, hydrocarbons in formations are treated in stages. FIG. 1 depicts an illustration of stages of heating the hydrocarbon containing formation. FIG. 1 also depicts an example of yield ("Y") in barrels of oil equivalent per ton (y axis) of formation fluids from the formation versus temperature ("T") of the heated
15 formation in degrees Celsius (x axis).

[0073] Desorption of methane and vaporization of water occurs during stage 1 heating. Heating of the formation through stage 1 may be performed as quickly as possible. For example, when the hydrocarbon containing formation is initially heated, hydrocarbons in the formation desorb adsorbed methane. The desorbed methane may be produced from the
20 formation. If the hydrocarbon containing formation is heated further, water in the hydrocarbon containing formation is vaporized. Water may occupy, in some hydrocarbon containing formations, between 10% and 50% of the pore volume in the formation. In other formations, water occupies larger or smaller portions of the pore volume. Water typically is vaporized in a formation between 160 °C and 285 °C at pressures of 600 kPa
25 absolute to 7000 kPa absolute. In some embodiments, the vaporized water produces wettability changes in the formation and/or increased formation pressure. The wettability changes and/or increased pressure may affect pyrolysis reactions or other reactions in the formation. In certain embodiments, the vaporized water is produced from the formation. In other embodiments, the vaporized water is used for steam extraction and/or distillation
30 in the formation or outside the formation. Removing the water from and increasing the pore volume in the formation increases the storage space for hydrocarbons in the pore volume.

[0074] In certain embodiments, after stage 1 heating, the formation is heated further, such that a temperature in the formation reaches (at least) an initial pyrolyzation temperature (such as a temperature at the lower end of the temperature range shown as stage 2). Hydrocarbons in the formation may be pyrolyzed throughout stage 2. A pyrolysis temperature range varies depending on the types of hydrocarbons in the formation. The pyrolysis temperature range may include temperatures between 250 °C and 900 °C. The pyrolysis temperature range for producing desired products may extend through only a portion of the total pyrolysis temperature range. In some embodiments, the pyrolysis temperature range for producing desired products may include temperatures between 250 °C and 400 °C or temperatures between 270 °C and 350 °C. If a temperature of hydrocarbons in the formation is slowly raised through the temperature range from 250 °C to 400 °C, production of pyrolysis products may be substantially complete when the temperature approaches 400 °C. Average temperature of the hydrocarbons may be raised at a rate of less than 5 °C per day, less than 2 °C per day, less than 1 °C per day, or less than 0.5 °C per day through the pyrolysis temperature range for producing desired products. Heating the hydrocarbon containing formation with a plurality of heat sources may establish thermal gradients around the heat sources that slowly raise the temperature of hydrocarbons in the formation through the pyrolysis temperature range.

[0075] The rate of temperature increase through the pyrolysis temperature range for desired products may affect the quality and quantity of the formation fluids produced from the hydrocarbon containing formation. Raising the temperature slowly through the pyrolysis temperature range for desired products may inhibit mobilization of large chain molecules in the formation. Raising the temperature slowly through the pyrolysis temperature range for desired products may limit reactions between mobilized hydrocarbons that produce undesired products. Slowly raising the temperature of the formation through the pyrolysis temperature range for desired products may allow for the production of high quality, high API gravity hydrocarbons from the formation. Slowly raising the temperature of the formation through the pyrolysis temperature range for desired products may allow for the removal of a large amount of the hydrocarbons present in the formation as hydrocarbon product.

[0076] In some in situ heat treatment embodiments, a portion of the formation is heated to a desired temperature instead of slowly heating the temperature through a temperature range. In some embodiments, the desired temperature is 300 °C, 325 °C, or 350 °C. Other

temperatures may be selected as the desired temperature. Superposition of heat from heat sources allows the desired temperature to be relatively quickly and efficiently established in the formation. Energy input into the formation from the heat sources may be adjusted to maintain the temperature in the formation substantially at the desired temperature. The heated portion of the formation is maintained substantially at the desired temperature until pyrolysis declines such that production of desired formation fluids from the formation becomes uneconomical. Parts of the formation that are subjected to pyrolysis may include regions brought into a pyrolysis temperature range by heat transfer from only one heat source.

[0077] In certain embodiments, formation fluids including pyrolyzation fluids are produced from the formation. As the temperature of the formation increases, the amount of condensable hydrocarbons in the produced formation fluid may decrease. At high temperatures, the formation may produce mostly methane and/or hydrogen. If the hydrocarbon containing formation is heated throughout an entire pyrolysis range, the formation may produce only small amounts of hydrogen towards an upper limit of the pyrolysis range. After all of the available hydrogen is depleted, a minimal amount of fluid production from the formation will typically occur.

[0078] After pyrolysis of hydrocarbons, a large amount of carbon and some hydrogen may still be present in the formation. A significant portion of carbon remaining in the formation can be produced from the formation in the form of synthesis gas. Synthesis gas generation may take place during stage 3 heating depicted in FIG. 1. Stage 3 may include heating a hydrocarbon containing formation to a temperature sufficient to allow synthesis gas generation. For example, synthesis gas may be produced in a temperature range from about 400 °C to about 1200 °C, about 500 °C to about 1100 °C, or about 550 °C to about 1000 °C. The temperature of the heated portion of the formation when the synthesis gas generating fluid is introduced to the formation determines the composition of synthesis gas produced in the formation. The generated synthesis gas may be removed from the formation through a production well or production wells.

[0079] Total energy content of fluids produced from the hydrocarbon containing formation may stay relatively constant throughout pyrolysis and synthesis gas generation. During pyrolysis at relatively low formation temperatures, a significant portion of the produced fluid may be condensable hydrocarbons that have a high energy content. At higher pyrolysis temperatures, however, less of the formation fluid may include condensable

hydrocarbons. More non-condensable formation fluids may be produced from the formation. Energy content per unit volume of the produced fluid may decline slightly during generation of predominantly non-condensable formation fluids. During synthesis gas generation, energy content per unit volume of produced synthesis gas declines
5 significantly compared to energy content of pyrolyzation fluid. The volume of the produced synthesis gas, however, will in many instances increase substantially, thereby compensating for the decreased energy content.

[0080] FIG. 2 depicts a schematic view of an embodiment of a portion of the in situ heat treatment system for treating the hydrocarbon containing formation. The in situ heat
10 treatment system may include barrier wells 100. Barrier wells are used to form a barrier around a treatment area. The barrier inhibits fluid flow into and/or out of the treatment area. Barrier wells include, but are not limited to, dewatering wells, vacuum wells, capture wells, injection wells, grout wells, freeze wells, or combinations thereof. In some
15 embodiments, barrier wells 100 are dewatering wells. Dewatering wells may remove liquid water and/or inhibit liquid water from entering a portion of the formation to be heated, or to the formation being heated. In the embodiment depicted in FIG. 2, the barrier wells 100 are shown extending only along one side of heat sources 102, but the barrier wells typically encircle all heat sources 102 used, or to be used, to heat a treatment area of the formation.

[0081] Heat sources 102 are placed in at least a portion of the formation. Heat sources 102
20 may include heaters such as insulated conductors, conductor-in-conduit heaters, surface burners, flameless distributed combustors, and/or natural distributed combustors. Heat sources 102 may also include other types of heaters. Heat sources 102 provide heat to at least a portion of the formation to heat hydrocarbons in the formation. Energy may be
25 supplied to heat sources 102 through supply lines 104. Supply lines 104 may be structurally different depending on the type of heat source or heat sources used to heat the formation. Supply lines 104 for heat sources may transmit electricity for electric heaters, may transport fuel for combustors, or may transport heat exchange fluid that is circulated in the formation. In some embodiments, electricity for an in situ heat treatment process
30 may be provided by a nuclear power plant or nuclear power plants. The use of nuclear power may allow for reduction or elimination of carbon dioxide emissions from the in situ heat treatment process.

[0082] Production wells 106 are used to remove formation fluid from the formation. In some embodiments, production well 106 includes a heat source. The heat source in the production well may heat one or more portions of the formation at or near the production well. In some in situ heat treatment process embodiments, the amount of heat supplied to the formation from the production well per meter of the production well is less than the amount of heat applied to the formation from a heat source that heats the formation per meter of the heat source.

[0083] In some embodiments, the heat source in production well 106 allows for vapor phase removal of formation fluids from the formation. Providing heating at or through the production well may: (1) inhibit condensation and/or refluxing of production fluid when such production fluid is moving in the production well proximate the overburden, (2) increase heat input into the formation, (3) increase production rate from the production well as compared to a production well without a heat source, (4) inhibit condensation of high carbon number compounds (C6 and above) in the production well, and/or (5) increase formation permeability at or proximate the production well.

[0084] Subsurface pressure in the formation may correspond to the fluid pressure generated in the formation. As temperatures in the heated portion of the formation increase, the pressure in the heated portion may increase as a result of increased fluid generation and vaporization of water. Controlling rate of fluid removal from the formation may allow for control of pressure in the formation. Pressure in the formation may be determined at a number of different locations, such as near or at production wells, near or at heat sources, or at monitor wells.

[0085] In some hydrocarbon containing formations, production of hydrocarbons from the formation is inhibited until at least some hydrocarbons in the formation have been pyrolyzed. Formation fluid may be produced from the formation when the formation fluid is of a selected quality. In some embodiments, the selected quality includes an API gravity of at least about 20°, 30°, or 40°. Inhibiting production until at least some hydrocarbons are pyrolyzed may increase conversion of heavy hydrocarbons to light hydrocarbons. Inhibiting initial production may minimize the production of heavy hydrocarbons from the formation. Production of substantial amounts of heavy hydrocarbons may require expensive equipment and/or reduce the life of production equipment.

[0086] After pyrolysis temperatures are reached and production from the formation is allowed, pressure in the formation may be varied to alter and/or control a composition of

formation fluid produced, to control a percentage of condensable fluid as compared to non-condensable fluid in the formation fluid, and/or to control an API gravity of formation fluid being produced. For example, decreasing pressure may result in production of a larger condensable fluid component. The condensable fluid component may contain a larger
5 percentage of olefins.

[0087] In some in situ heat treatment process embodiments, pressure in the formation may be maintained high enough to promote production of formation fluid with an API gravity of greater than 20°. Maintaining increased pressure in the formation may inhibit formation subsidence during in situ heat treatment. Maintaining increased pressure may facilitate
10 vapor phase production of fluids from the formation. Vapor phase production may allow for a reduction in size of collection conduits used to transport fluids produced from the formation. Maintaining increased pressure may reduce or eliminate the need to compress formation fluids at the surface to transport the fluids in collection conduits to treatment facilities.

[0088] Maintaining increased pressure in a heated portion of the formation may surprisingly allow for production of large quantities of hydrocarbons of increased quality and of relatively low molecular weight. Pressure may be maintained so that formation fluid produced has a minimal amount of compounds above a selected carbon number. The selected carbon number may be at most 25, at most 20, at most 12, or at most 8. Some
20 high carbon number compounds may be entrained in vapor in the formation and may be removed from the formation with the vapor. Maintaining increased pressure in the formation may inhibit entrainment of high carbon number compounds and/or multi-ring hydrocarbon compounds in the vapor. High carbon number compounds and/or multi-ring hydrocarbon compounds may remain in a liquid phase in the formation for significant time
25 periods. The significant time periods may provide sufficient time for the compounds to pyrolyze to form lower carbon number compounds.

[0089] Formation fluid produced from production wells 106 may be transported through collection piping 108 to treatment facilities 110. Formation fluids may also be produced from heat sources 102. For example, fluid may be produced from heat sources 102 to
30 control pressure in the formation adjacent to the heat sources. Fluid produced from heat sources 102 may be transported through tubing or piping to collection piping 108 or the produced fluid may be transported through tubing or piping directly to treatment facilities 110. Treatment facilities 110 may include separation units, reaction units, upgrading units,

fuel cells, turbines, storage vessels, and/or other systems and units for processing produced formation fluids. The treatment facilities may form transportation fuel from at least a portion of the hydrocarbons produced from the formation. In some embodiments, the transportation fuel may be jet fuel, such as JP-8.

- 5 [0090] In certain embodiments, a temperature limited heater is utilized for heavy oil applications (for example, treatment of relatively permeable formations or tar sands formations). A temperature limited heater may provide a relatively low Curie temperature and/or phase transformation temperature range so that a maximum average operating temperature of the heater is less than 350 °C, 300 °C, 250 °C, 225 °C, 200 °C, or 150 °C.
- 10 In an embodiment (for example, for a tar sands formation), a maximum temperature of the heater is less than about 250 °C to inhibit olefin generation and production of other cracked products. In some embodiments, a maximum temperature of the heater above about 250 °C is used to produce lighter hydrocarbon products. For example, the maximum temperature of the heater may be at or less than about 500 °C.
- 15 [0091] A heater may heat a volume of formation adjacent to a production wellbore (a near production wellbore region) so that the temperature of fluid in the production wellbore and in the volume adjacent to the production wellbore is less than the temperature that causes degradation of the fluid. The heat source may be located in the production wellbore or near the production wellbore. In some embodiments, the heat source is a temperature
- 20 limited heater. In some embodiments, two or more heat sources may supply heat to the volume. Heat from the heat source may reduce the viscosity of crude oil in or near the production wellbore. In some embodiments, heat from the heat source mobilizes fluids in or near the production wellbore and/or enhances the flow of fluids to the production wellbore. In some embodiments, reducing the viscosity of crude oil allows or enhances gas
- 25 lifting of heavy oil (approximately at most 10° API gravity oil) or intermediate gravity oil (approximately 12° to 20° API gravity oil) from the production wellbore. In certain embodiments, the initial API gravity of oil in the formation is at most 10°, at most 20°, at most 25°, or at most 30°. In certain embodiments, the viscosity of oil in the formation is at least 0.05 Pa·s (50 cp). In some embodiments, the viscosity of oil in the formation is at
- 30 least 0.10 Pa·s (100 cp), at least 0.15 Pa·s (150 cp), or at least at least 0.20 Pa·s (200 cp). Large amounts of natural gas may have to be utilized to provide gas lift of oil with viscosities above 0.05 Pa·s. Reducing the viscosity of oil at or near the production wellbore in the formation to a viscosity of 0.05 Pa·s (50 cp), 0.03 Pa·s (30 cp), 0.02 Pa·s

(20 cp), 0.01 Pa·s (10 cp), or less (down to 0.001 Pa·s (1 cp) or lower) lowers the amount of natural gas needed to lift oil from the formation. In some embodiments, reduced viscosity oil is produced by other methods such as pumping.

[0092] The rate of production of oil from the formation may be increased by raising the temperature at or near a production wellbore to reduce the viscosity of the oil in the formation in and adjacent to the production wellbore. In certain embodiments, the rate of production of oil from the formation is increased by 2 times, 3 times, 4 times, or greater, or up to 20 times over standard cold production, which has no external heating of formation during production. Certain formations may be more economically viable for enhanced oil production using the heating of the near production wellbore region. Formations that have a cold production rate approximately between $0.05 \text{ m}^3/(\text{day per meter of wellbore length})$ and $0.20 \text{ m}^3/(\text{day per meter of wellbore length})$ may have significant improvements in production rate using heating to reduce the viscosity in the near production wellbore region. In some formations, production wells up to 775 m, up to 1000 m, or up to 1500 m in length are used. For example, production wells between 450 m and 775 m in length are used, between 550 m and 800 m are used, or between 650 m and 900 m are used. Thus, a significant increase in production is achievable in some formations. Heating the near production wellbore region may be used in formations where the cold production rate is not between $0.05 \text{ m}^3/(\text{day per meter of wellbore length})$ and $0.20 \text{ m}^3/(\text{day per meter of wellbore length})$, but heating such formations may not be as economically favorable. Higher cold production rates may not be significantly increased by heating the near wellbore region, while lower production rates may not be increased to an economically useful value.

[0093] Using the temperature limited heater to reduce the viscosity of oil at or near the production well inhibits problems associated with non-temperature limited heaters and heating the oil in the formation due to hot spots. One possible problem is that non-temperature limited heaters can causing coking of oil at or near the production well if the heater overheats the oil because the heaters are at too high a temperature. Higher temperatures in the production well may also cause brine to boil in the well, which may lead to scale formation in the well. Non-temperature limited heaters that reach higher temperatures may also cause damage to other wellbore components (for example, screens used for sand control, pumps, or valves). Hot spots may be caused by portions of the formation expanding against or collapsing on the heater. In some embodiments, the heater

(either the temperature limited heater or another type of non-temperature limited heater) has sections that are lower because of sagging over long heater distances. These lower sections may sit in heavy oil or bitumen that collects in lower portions of the wellbore. At these lower sections, the heater may develop hot spots due to coking of the heavy oil or bitumen. A standard non-temperature limited heater may overheat at these hot spots, thus producing a non-uniform amount of heat along the length of the heater. Using the temperature limited heater may inhibit overheating of the heater at hot spots or lower sections and provide more uniform heating along the length of the wellbore.

[0094] In certain embodiments, fluids in the relatively permeable formation containing heavy hydrocarbons are produced with little or no pyrolyzation of hydrocarbons in the formation. In certain embodiments, the relatively permeable formation containing heavy hydrocarbons is a tar sands formation. For example, the formation may be a tar sands formation such as the Athabasca tar sands formation in Alberta, Canada or a carbonate formation such as the Grosmont carbonate formation in Alberta, Canada. The fluids produced from the formation are mobilized fluids. Producing mobilized fluids may be more economical than producing pyrolyzed fluids from the tar sands formation. Producing mobilized fluids may also increase the total amount of hydrocarbons produced from the tar sands formation.

[0095] FIGS. 3-6 depict side view representations of embodiments for producing mobilized fluids from tar sands formations. In FIGS. 3-6, heaters 116 have substantially horizontal heating sections in hydrocarbon layer 114 (as shown, the heaters have heating sections that go into and out of the page). Hydrocarbon layer 114 may be below overburden 112. FIG. 3 depicts a side view representation of an embodiment for producing mobilized fluids from a tar sands formation with a relatively thin hydrocarbon layer. FIG. 4 depicts a side view representation of an embodiment for producing mobilized fluids from a hydrocarbon layer that is thicker than the hydrocarbon layer depicted in FIG. 3. FIG. 5 depicts a side view representation of an embodiment for producing mobilized fluids from a hydrocarbon layer that is thicker than the hydrocarbon layer depicted in FIG. 4. FIG. 6 depicts a side view representation of an embodiment for producing mobilized fluids from a tar sands formation with a hydrocarbon layer that has a shale break.

[0096] In FIG. 3, heaters 116 are placed in an alternating triangular pattern in hydrocarbon layer 114. In FIGS. 4, 5, and 6, heaters 116 are placed in an alternating triangular pattern in hydrocarbon layer 114 that repeats vertically to encompass a majority or all of the

hydrocarbon layer. In FIG. 6, the alternating triangular pattern of heaters 116 in hydrocarbon layer 114 repeats uninterrupted across shale break 118. In FIGS. 3-6, heaters 116 may be equidistantly spaced from each other. In the embodiments depicted in FIGS. 3-6, the number of vertical rows of heaters 116 depends on factors such as, but not limited to, the desired spacing between the heaters, the thickness of hydrocarbon layer 114, and/or the number and location of shale breaks 118. In some embodiments, heaters 116 are arranged in other patterns. For example, heaters 116 may be arranged in patterns such as, but not limited to, hexagonal patterns, square patterns, or rectangular patterns.

[0097] In the embodiments depicted in FIGS. 3-6, heaters 116 provide heat that mobilizes hydrocarbons (reduces the viscosity of the hydrocarbons) in hydrocarbon layer 114. In certain embodiments, heaters 116 provide heat that reduces the viscosity of the hydrocarbons in hydrocarbon layer 114 below about 0.50 Pa·s (500 cp), below about 0.10 Pa·s (100 cp), or below about 0.05 Pa·s (50 cp). The spacing between heaters 116 and/or the heat output of the heaters may be designed and/or controlled to reduce the viscosity of the hydrocarbons in hydrocarbon layer 114 to desirable values. Heat provided by heaters 116 may be controlled so that little or no pyrolyzation occurs in hydrocarbon layer 114. Superposition of heat between the heaters may create one or more drainage paths (for example, paths for flow of fluids) between the heaters. In certain embodiments, production wells 106A and/or production wells 106B are located proximate heaters 116 so that heat from the heaters superimposes over the production wells. The superimposition of heat from heaters 116 over production wells 106A and/or production wells 106B creates one or more drainage paths from the heaters to the production wells. In certain embodiments, one or more of the drainage paths converge. For example, the drainage paths may converge at or near a bottommost heater and/or the drainage paths may converge at or near production wells 106A and/or production wells 106B. Fluids mobilized in hydrocarbon layer 114 tend to flow towards the bottommost heaters 116, production wells 106A and/or production wells 106B in the hydrocarbon layer because of gravity and the heat and pressure gradients established by the heaters and/or the production wells. The drainage paths and/or the converged drainage paths allow production wells 106A and/or production wells 106B to collect mobilized fluids in hydrocarbon layer 114.

[0098] In certain embodiments, hydrocarbon layer 114 has sufficient permeability to allow mobilized fluids to drain to production wells 106A and/or production wells 106B. For example, hydrocarbon layer 114 may have a permeability of at least about 0.1 darcy, at

least about 1 darcy, at least about 10 darcy, or at least about 100 darcy. In some embodiments, hydrocarbon layer 114 has a relatively large vertical permeability to horizontal permeability ratio (K_v/K_h). For example, hydrocarbon layer 114 may have a K_v/K_h ratio between about 0.01 and about 2, between about 0.1 and about 1, or between
5 about 0.3 and about 0.7.

[0099] In certain embodiments, fluids are produced through production wells 106A located near heaters 116 in the lower portion of hydrocarbon layer 114. In some embodiments, fluids are produced through production wells 106B located below and approximately midway between heaters 116 in the lower portion of hydrocarbon layer 114. At least a
10 portion of production wells 106A and/or production wells 106B may be oriented substantially horizontal in hydrocarbon layer 114 (as shown in FIGS. 3-6, the production wells have horizontal portions that go into and out of the page). Production wells 106A and/or 106B may be located proximate lower portion heaters 116 or the bottommost heaters.

15 [0100] In some embodiments, production wells 106A are positioned substantially vertically below the bottommost heaters in hydrocarbon layer 114. Production wells 106A may be located below heaters 116 at the bottom vertex of a pattern of the heaters (for example, at the bottom vertex of the triangular pattern of heaters depicted in FIGS. 3-6). Locating production wells 106A substantially vertically below the bottommost heaters may
20 allow for efficient collection of mobilized fluids from hydrocarbon layer 114.

[0101] In certain embodiments, the bottommost heaters are located between about 2 m and about 10 m from the bottom of hydrocarbon layer 114, between about 4 m and about 8 m from the bottom of the hydrocarbon layer, or between about 5 m and about 7 m from the bottom of the hydrocarbon layer. In certain embodiments, production wells 106A and/or
25 production wells 106B are located at a distance from the bottommost heaters 116 that allows heat from the heaters to superimpose over the production wells but at a distance from the heaters that inhibits coking at the production wells. Production wells 106A and/or production wells 106B may be located a distance from the nearest heater (for example, the bottommost heater) of at most $\frac{3}{4}$ of the spacing between heaters in the pattern of heaters
30 (for example, the triangular pattern of heaters depicted in FIGS. 3-6). In some embodiments, production wells 106A and/or production wells 106B are located a distance from the nearest heater of at most $\frac{2}{3}$, at most $\frac{1}{2}$, or at most $\frac{1}{3}$ of the spacing between heaters in the pattern of heaters. In certain embodiments, production wells 106A and/or

production wells 106B are located between about 2 m and about 10 m from the bottommost heaters, between about 4 m and about 8 m from the bottommost heaters, or between about 5 m and about 7 m from the bottommost heaters. Production wells 106A and/or production wells 106B may be located between about 0.5 m and about 8 m from the bottom of hydrocarbon layer 114, between about 1 m and about 5 m from the bottom of the hydrocarbon layer, or between about 2 m and about 4 m from the bottom of the hydrocarbon layer.

[0102] In some embodiments, at least some production wells 106A are located substantially vertically below heaters 116 near shale break 118, as depicted in FIG. 6. Production wells 106A may be located between heaters 116 and shale break 118 to produce fluids that flow and collect above the shale break. Shale break 118 may be an impermeable barrier in hydrocarbon layer 114. In some embodiments, shale break 118 has a thickness between about 1 m and about 6 m, between about 2 m and about 5 m, or between about 3 m and about 4 m. Production wells 106A between heaters 116 and shale break 118 may produce fluids from the upper portion of hydrocarbon layer 114 (above the shale break) and production wells 106A below the bottommost heaters in the hydrocarbon layer may produce fluids from the lower portion of the hydrocarbon layer (below the shale break), as depicted in FIG. 6. In some embodiments, two or more shale breaks may exist in a hydrocarbon layer. In such an embodiment, production wells are placed at or near each of the shale breaks to produce fluids flowing and collecting above the shale breaks.

[0103] In some embodiments, shale break 118 breaks down (is desiccated) as the shale break is heated by heaters 116 on either side of the shale break. As shale break 118 breaks down, the permeability of the shale break increases and the shale break allows fluids to flow through the shale break. Once fluids are able to flow through shale break 118, production wells above the shale break may not be needed for production as fluids can flow to production wells at or near the bottom of hydrocarbon layer 114 and be produced there.

[0104] In certain embodiments, the bottommost heaters above shale break 118 are located between about 2 m and about 10 m from the shale break, between about 4 m and about 8 m from the bottom of the shale break, or between about 5 m and about 7 m from the shale break. Production wells 106A may be located between about 2 m and about 10 m from the bottommost heaters above shale break 118, between about 4 m and about 8 m from the bottommost heaters above the shale break, or between about 5 m and about 7 m from the

bottommost heaters above the shale break. Production wells 106A may be located between about 0.5 m and about 8 m from shale break 118, between about 1 m and about 5 m from the shale break, or between about 2 m and about 4 m from the shale break.

[0105] In some embodiments, heat is provided in production wells 106A and/or production wells 106B, depicted in FIGS. 3-6. Providing heat in production wells 106A and/or production wells 106B may maintain and/or enhance the mobility of the fluids in the production wells. Heat provided in production wells 106A and/or production wells 106B may superpose with heat from heaters 116 to create the flow path from the heaters to the production wells. In some embodiments, production wells 106A and/or production wells 106B include a pump to move fluids to the surface of the formation. In some embodiments, the viscosity of fluids (oil) in production wells 106A and/or production wells 106B is lowered using heaters and/or diluent injection (for example, using a conduit in the production wells for injecting the diluent).

[0106] In certain embodiments, in situ heat treatment of the relatively permeable formation containing hydrocarbons (for example, the tar sands formation) includes heating the formation to visbreaking temperatures. For example, the formation may be heated to temperatures between about 100 °C and 260 °C, between about 150 °C and about 250 °C, between about 200 °C and about 240 °C, between about 205 °C and 230 °C, between about 210 °C and 225 °C. In one embodiment, the formation is heated to a temperature of about 220 °C. In one embodiment, the formation is heated to a temperature of about 230 °C. At visbreaking temperatures, fluids in the formation have a reduced viscosity (versus their initial viscosity at initial formation temperature) that allows fluids to flow in the formation. The reduced viscosity at visbreaking temperatures may be a permanent reduction in viscosity as the hydrocarbons go through a step change in viscosity at visbreaking temperatures (versus heating to mobilization temperatures, which may only temporarily reduce the viscosity). The visbroken fluids may have API gravities that are relatively low (for example, at most about 10°, about 12°, about 15°, or about 19° API gravity), but the API gravities are higher than the API gravity of non-visbroken fluid from the formation. The non-visbroken fluid from the formation may have an API gravity of 7° or less.

[0107] In some embodiments, heaters in the formation are operated at full power output to heat the formation to visbreaking temperatures or higher temperatures. Operating at full power may rapidly increase the pressure in the formation. In certain embodiments, fluids are produced from the formation to maintain a pressure in the formation below a selected

pressure as the temperature of the formation increases. In some embodiments, the selected pressure is a fracture pressure of the formation. In certain embodiments, the selected pressure is between about 1000 kPa and about 15000 kPa, between about 2000 kPa and about 10000 kPa, or between about 2500 kPa and about 5000 kPa. In one embodiment, the selected pressure is about 10000 kPa. Maintaining the pressure as close to the fracture pressure as possible may minimize the number of production wells needed for producing fluids from the formation.

[0108] In certain embodiments, treating the formation includes maintaining the temperature at or near visbreaking temperatures (as described above) during the entire production phase while maintaining the pressure below the fracture pressure. The heat provided to the formation may be reduced or eliminated to maintain the temperature at or near visbreaking temperatures. Heating to visbreaking temperatures but maintaining the temperature below pyrolysis temperatures or near pyrolysis temperatures (for example, below about 230 °C) inhibits coke formation and/or higher level reactions. Heating to visbreaking temperatures at higher pressures (for example, pressures near but below the fracture pressure) keeps produced gases in the liquid oil (hydrocarbons) in the formation and increases hydrogen reduction in the formation with higher hydrogen partial pressures. Heating the formation to only visbreaking temperatures also uses less energy input than heating the formation to pyrolysis temperatures.

[0109] Fluids produced from the formation may include visbroken fluids, mobilized fluids, and/or pyrolyzed fluids. In some embodiments, a produced mixture that includes these fluids is produced from the formation. The produced mixture may have assessable properties (for example, measurable properties). The produced mixture properties are determined by operating conditions in the formation being treated (for example, temperature and/or pressure in the formation). In certain embodiments, the operating conditions may be selected, varied, and/or maintained to produce desirable properties in the produced mixture. For example, the produced mixture may have properties that allow the mixture to be easily transported (for example, sent through a pipeline without adding diluent or blending the mixture with another fluid).

[0110] Examples of produced mixture properties that may be measured and used to assess the produced mixture include, but are not limited to, liquid hydrocarbon properties such as API gravity, viscosity, asphaltene stability (P-value), and bromine number. In certain embodiments, operating conditions are selected, varied, and/or maintained to produce an

API gravity of at least about 15°, at least about 17°, at least about 19°, or at least about 20° in the produced mixture. In certain embodiments, operating conditions are selected, varied, and/or maintained to produce a viscosity (measured at 1 atm and 5 °C) of at most about 400 cp, at most about 350 cp, at most about 250 cp, or at most about 100 cp in the produced mixture. As an example, the initial viscosity in the formation of above about 5 1000 cp or, in some cases, above about 1 million cp. In certain embodiments, operating conditions are selected, varied, and/or maintained to produce an asphaltene stability (P-value) of at least about 1, at least about 1.1, at least about 1.2, or at least about 1.3 in the produced mixture. In certain embodiments, operating conditions are selected, varied, and/or maintained to produce a bromine number of at most about 3%, at most about 2.5%, at most about 2%, or at most about 1.5% in the produced mixture.

[0111] In certain embodiments, the mixture is produced from one or more production wells located at or near the bottom of the hydrocarbon layer being treated. In other embodiments, the mixture is produced from other locations in the hydrocarbon layer being treated (for example, from an upper portion of the layer or a middle portion of the layer).

[0112] In one embodiment, the formation is heated to 220 °C or 230 °C while maintaining the pressure in the formation below 10000 kPa. The mixture produced from the formation may have several desirable properties such as, but not limited to, an API gravity of at least 19°, a viscosity of at most 350 cp, a P-value of at least 1.1, and a bromine number of at most 2%. Such a produced mixture may be transportable through a pipeline without adding diluent or blending the mixture with another fluid. The mixture may be produced from one or more production wells located at or near the bottom of the hydrocarbon layer being treated.

[0113] In some embodiments, after the formation reaches visbreaking temperatures, the pressure in the formation is reduced. In certain embodiments, the pressure in the formation is reduced at temperatures above visbreaking temperatures. Reducing the pressure at higher temperatures allows more of the hydrocarbons in the formation to be converted to higher quality hydrocarbons by visbreaking and/or pyrolysis. Allowing the formation to reach higher temperatures before pressure reduction, however, may increase the amount of carbon dioxide produced and/or the amount of coking in the formation. For example, in some formations, coking of bitumen (at pressures above 700 kPa) begins at about 280 °C and reaches a maximum rate at about 340 °C. At pressures below about 700 kPa, the coking rate in the formation is minimal. Allowing the formation to reach higher

temperatures before pressure reduction may decrease the amount of hydrocarbons produced from the formation.

[0114] In certain embodiments, the temperature in the formation (for example, an average temperature of the formation) when the pressure in the formation is reduced is selected to
5 balance one or more factors. The factors considered may include: the quality of hydrocarbons produced, the amount of hydrocarbons produced, the amount of carbon dioxide produced, the amount hydrogen sulfide produced, the degree of coking in the formation, and/or the amount of water produced. Experimental assessments using formation samples and/or simulated assessments based on the formation properties may be
10 used to assess results of treating the formation using the in situ heat treatment process. These results may be used to determine a selected temperature, or temperature range, for when the pressure in the formation is to be reduced. The selected temperature, or temperature range, may also be affected by factors such as, but not limited to, hydrocarbon or oil market conditions and other economic factors. In certain embodiments, the selected
15 temperature is in a range between about 275 °C and about 305 °C, between about 280 °C and about 300 °C, or between about 285 °C and about 295 °C.

[0115] In certain embodiments, an average temperature in the formation is assessed from an analysis of fluids produced from the formation. For example, the average temperature of the formation may be assessed from an analysis of the fluids that have been produced to
20 maintain the pressure in the formation below the fracture pressure of the formation.

[0116] In some embodiments, values of the hydrocarbon isomer shift in fluids (for example, gases) produced from the formation is used to indicate the average temperature in the formation. Experimental analysis and/or simulation may be used to assess one or more hydrocarbon isomer shifts and relate the values of the hydrocarbon isomer shifts to the
25 average temperature in the formation. The assessed relation between the hydrocarbon isomer shifts and the average temperature may then be used in the field to assess the average temperature in the formation by monitoring one or more of the hydrocarbon isomer shifts in fluids produced from the formation. In some embodiments, the pressure in the formation is reduced when the monitored hydrocarbon isomer shift reaches a selected
30 value. The selected value of the hydrocarbon isomer shift may be chosen based on the selected temperature, or temperature range, in the formation for reducing the pressure in the formation and the assessed relation between the hydrocarbon isomer shift and the average temperature. Examples of hydrocarbon isomer shifts that may be assessed include,

but are not limited to, n-butane- $\delta^{13}\text{C}_4$ percentage versus propane- $\delta^{13}\text{C}_3$ percentage, n-pentane- $\delta^{13}\text{C}_5$ percentage versus propane- $\delta^{13}\text{C}_3$ percentage, n-pentane- $\delta^{13}\text{C}_5$ percentage versus n-butane- $\delta^{13}\text{C}_4$ percentage, and i-pentane- $\delta^{13}\text{C}_5$ percentage versus i-butane- $\delta^{13}\text{C}_4$ percentage. In some embodiments, the hydrocarbon isomer shift in produced fluids is used
5 to indicate the amount of conversion (for example, amount of pyrolysis) that has taken place in the formation.

[0117] In some embodiments, weight percentages of saturates in fluids produced from the formation is used to indicate the average temperature in the formation. Experimental analysis and/or simulation may be used to assess the weight percentage of saturates as a
10 function of the average temperature in the formation. For example, SARA (Saturates, Aromatics, Resins, and Asphaltenes) analysis (sometimes referred to as Asphaltene/Wax/Hydrate Deposition analysis) may be used to assess the weight percentage of saturates in a sample of fluids from the formation. In some formations, the weight percentage of saturates has a linear relationship to the average temperature in the
15 formation. The relation between the weight percentage of saturates and the average temperature may then be used in the field to assess the average temperature in the formation by monitoring the weight percentage of saturates in fluids produced from the formation. In some embodiments, the pressure in the formation is reduced when the monitored weight percentage of saturates reaches a selected value. The selected value of
20 the weight percentage of saturates may be chosen based on the selected temperature, or temperature range, in the formation for reducing the pressure in the formation and the relation between the weight percentage of saturates and the average temperature.

[0118] In some embodiments, weight percentages of n-C₇ in fluids produced from the formation is used to indicate the average temperature in the formation. Experimental
25 analysis and/or simulation may be used to assess the weight percentages of n-C₇ as a function of the average temperature in the formation. In some formations, the weight percentages of n-C₇ has a linear relationship to the average temperature in the formation. The relation between the weight percentages of n-C₇ and the average temperature may then be used in the field to assess the average temperature in the formation by monitoring the
30 weight percentages of n-C₇ in fluids produced from the formation. In some embodiments, the pressure in the formation is reduced when the monitored weight percentage of n-C₇ reaches a selected value. The selected value of the weight percentage of n-C₇ may be chosen based on the selected temperature, or temperature range, in the formation for

reducing the pressure in the formation and the relation between the weight percentage of n-C₇ and the average temperature.

[0119] The pressure in the formation may be reduced by producing fluids (for example, visbroken fluids and/or mobilized fluids) from the formation. In some embodiments, the pressure is reduced below a pressure at which fluids coke in the formation to inhibit coking at pyrolysis temperatures. For example, the pressure is reduced to a pressure below about 1000 kPa, below about 800 kPa, or below about 700 kPa (for example, about 690 kPa). In certain embodiments, the selected pressure is at least about 100 kPa, at least about 200 kPa, or at least about 300 kPa. The pressure may be reduced to inhibit coking of asphaltenes or other high molecular weight hydrocarbons in the formation. In some embodiments, the pressure may be maintained below a pressure at which water passes through a liquid phase at downhole (formation) temperatures to inhibit liquid water and dolomite reactions. After reducing the pressure in the formation, the temperature may be increased to pyrolysis temperatures to begin pyrolyzation and/or upgrading of fluids in the formation. The pyrolyzed and/or upgraded fluids may be produced from the formation.

[0120] In certain embodiments, the amount of fluids produced at temperatures below visbreaking temperatures, the amount of fluids produced at visbreaking temperatures, the amount of fluids produced before reducing the pressure in the formation, and/or the amount of upgraded or pyrolyzed fluids produced may be varied to control the quality and amount of fluids produced from the formation and the total recovery of hydrocarbons from the formation. For example, producing more fluid during the early stages of treatment (for example, producing fluids before reducing the pressure in the formation) may increase the total recovery of hydrocarbons from the formation while reducing the overall quality (lowering the overall API gravity) of fluid produced from the formation. The overall quality is reduced because more heavy hydrocarbons are produced by producing more fluids at the lower temperatures. Producing less fluids at the lower temperatures may increase the overall quality of the fluids produced from the formation but may lower the total recovery of hydrocarbons from the formation. The total recovery may be lower because more coking occurs in the formation when less fluids are produced at lower temperatures.

[0121] In certain embodiments, the formation is heated using isolated cells of heaters (cells or sections of the formation that are not interconnected for fluid flow). The isolated cells may be created by using larger heater spacings in the formation. For example, large heater

spacings may be used in the embodiments depicted in FIGS. 3-6. These isolated cells may be produced during early stages of heating (for example, at temperatures below visbreaking temperatures). Because the cells are isolated from other cells in the formation, the pressures in the isolated cells are high and more liquids are producible from the isolated cells. Thus, more liquids may be produced from the formation and a higher total recovery of hydrocarbons may be reached. During later stages of heating, the heat gradient may interconnect the isolated cells and pressures in the formation will drop.

[0122] In certain embodiments, the heat gradient in the formation is modified so that a gas cap is created at or near an upper portion of the hydrocarbon layer. For example, the heat gradient made by heaters 116 depicted in the embodiments depicted in FIGS. 3-6 may be modified to create the gas cap at or near overburden 112 of hydrocarbon layer 114. The gas cap may push or drive liquids to the bottom of the hydrocarbon layer so that more liquids may be produced from the formation. In situ generation of the gas cap may be more efficient than introducing pressurized fluid into the formation. The in situ generated gas cap applies force evenly through the formation with little or no channeling or fingering that may reduce the effectiveness of introduced pressurized fluid.

[0123] In certain embodiments, the number and/or location of production wells in the formation is varied based on the viscosity of the formation. More or less production wells may be located in zones of the formation with different viscosities. The viscosities of the zones may be assessed before placing the production wells in the formation, before heating the formation, and/or after heating the formation. In some embodiments, more production wells are located in zones in the formation that have lower viscosities. For example, in certain formations, upper portions, or zones, of the formation may have lower viscosities. Thus, more production wells may be located in the upper zones. Locating production wells in the less viscous zones of the formation allows for better pressure control in the formation and/or producing higher quality (more upgraded) oil from the formation.

[0124] In some embodiments, zones in the formation with different assessed viscosities are heated at different rates. In certain embodiments, zones in the formation with higher viscosities are heated at higher heating rates than zones with lower viscosities. Heating the zones with higher viscosities at the higher heating rates mobilizes and/or upgrades these zones at a faster rate so that these zones may “catch up” in viscosity and/or quality to the slower heated zones.

[0125] In some embodiments, the heater spacing is varied to provide different heating rates to zones in the formation with different assessed viscosities. For example, denser heater spacings (less spaces between heaters) may be used in zones with higher viscosities to heat these zones at higher heating rates. In some embodiments, a production well (for example, a substantially vertical production well) is located in the zones with denser heater spacings and higher viscosities. The production well may be used to remove fluids from the formation and relieve pressure from the higher viscosity zones. In some embodiments, one or more substantially vertical openings, or production wells, are located in the higher viscosity zones to allow fluids to drain in the higher viscosity zones. The draining fluids may be produced from the formation through production wells located near the bottom of the higher viscosity zones.

[0126] In certain embodiments, production wells are located in more than one zone in the formation. The zones may have different initial permeabilities. In certain embodiments, a first zone has an initial permeability of at least about 1 darcy and a second zone has an initial permeability of at most about 0.1 darcy. In some embodiments, the first zone has an initial permeability of between about 1 darcy and about 10 darcy. In some embodiments, the second zone has an initial permeability between about 0.01 darcy and 0.1 darcy. The zones may be separated by a substantially impermeable barrier (with an initial permeability of at most about 10 μ darcy or less). Having the production well located in both zones allows for fluid communication (permeability) between the zones and/or pressure equalization between the zones.

[0127] In some embodiments, openings (for example, substantially vertical openings) are formed between zones with different initial permeabilities that are separated by a substantially impermeable barrier. Bridging the zones with the openings allows for fluid communication (permeability) between the zones and/or pressure equalization between the zones. In some embodiments, openings in the formation (such as pressure relief openings and/or production wells) allow gases or low viscosity fluids to rise in the openings. As the gases or low viscosity fluids rise, the fluids may condense or increase viscosity in the openings so that the fluids drain back down the openings to be further upgraded in the formation. Thus, the openings may act as heat pipes by transferring heat from the lower portions to the upper portions where the fluids condense. The wellbores may be packed and sealed near or at the overburden to inhibit transport of formation fluid to the surface.

- [0128] In some embodiments, production of fluids is continued after reducing and/or turning off heating of the formation. The formation may be heated for a selected time. For example, the formation may be heated until it reaches a selected average temperature. Production from the formation may continue after the selected time. Continuing
5 production may produce more fluid from the formation as fluids drain towards the bottom of the formation and/or fluids are upgraded by passing by hot spots in the formation. In some embodiments, a horizontal production well is located at or near the bottom of the formation (or a zone of the formation) to produce fluids after heating is turned down and/or off.
- 10 [0129] In certain embodiments, initially produced fluids (for example, fluids produced below visbreaking temperatures), fluids produced at visbreaking temperatures, and/or other viscous fluids produced from the formation are blended with diluent to produce fluids with lower viscosities. In some embodiments, the diluent includes upgraded or pyrolyzed fluids produced from the formation. In some embodiments, the diluent includes upgraded or
15 pyrolyzed fluids produced from another portion of the formation or another formation. In certain embodiments, the amount of fluids produced at temperatures below visbreaking temperatures and/or fluids produced at visbreaking temperatures that are blended with upgraded fluids from the formation is adjusted to create a fluid suitable for transportation and/or use in a refinery. The amount of blending may be adjusted so that the fluid has
20 chemical and physical stability. Maintaining the chemical and physical stability of the fluid may allow the fluid to be transported, reduce pre-treatment processes at a refinery and/or reduce or eliminate the need for adjusting the refinery process to compensate for the fluid.
- [0130] In certain embodiments, formation conditions (for example, pressure and
25 temperature) and/or fluid production are controlled to produce fluids with selected properties. For example, formation conditions and/or fluid production may be controlled to produce fluids with a selected API gravity and/or a selected viscosity. The selected API gravity and/or selected viscosity may be produced by combining fluids produced at different formation conditions (for example, combining fluids produced at different
30 temperatures during the treatment as described above). As an example, formation conditions and/or fluid production may be controlled to produce fluids with an API gravity of about 19° and a viscosity of about 0.35 Pa·s (350 cp) at 19 °C.

[0131] In some embodiments, formation conditions and/or fluid production is controlled so that water (for example, connate water) is recondensed in the treatment area.

Recondensing water in the treatment area keeps the heat of condensation in the formation.

In addition, having liquid water in the formation may increase mobility of liquid

5 hydrocarbons (oil) in the formation. Liquid water may wet rock or other strata in the formation by occupying pores or corners in the strata and creating a slick surface that allows liquid hydrocarbons to move more readily through the formation.

[0132] In certain embodiments, a drive process (for example, a steam injection process such as cyclic steam injection, a steam assisted gravity drainage process (SAGD), a solvent
10 injection process, a vapor solvent and SAGD process, or a carbon dioxide injection process) is used to treat the tar sands formation in addition to the in situ heat treatment process. In some embodiments, heaters are used to create high permeability zones (or injection zones) in the formation for the drive process. Heaters may be used to create a mobilization geometry or production network in the formation to allow fluids to flow
15 through the formation during the drive process. For example, heaters may be used to create drainage paths between the heaters and production wells for the drive process. In some embodiments, the heaters are used to provide heat during the drive process. The amount of heat provided by the heaters may be small compared to the heat input from the drive process (for example, the heat input from steam injection).

20 [0133] In some embodiments, the in situ heat treatment process creates or produces the drive fluid in situ. The in situ produced drive fluid may move through the formation and move mobilized hydrocarbons from one portion of the formation to another portion of the formation.

[0134] In some embodiments, the in situ heat treatment process may provide less heat to
25 the formation (for example, use a wider heater spacing) if the in situ heat treatment process is followed by the drive process. The drive process may be used to increase the amount of heat provided to the formation to compensate for the loss of heat injection.

[0135] In some embodiments, the drive process is used to treat the formation and produce hydrocarbons from the formation. The drive process may recover a low amount of oil in
30 place from the formation (for example, less than 20% recovery of oil in place from the formation). The in situ heat treatment process may be used following the drive process to increase the recovery of oil in place from the formation. In some embodiments, the drive process preheats the formation for the in situ heat treatment process. In some

embodiments, the formation is treated using the in situ heat treatment process a significant time after the formation has been treated using the drive process. For example, the in situ heat treatment process is used 1 year, 2 years, 3 years, or longer after a formation has been treated using the drive process. The in situ heat treatment process may be used on
5 formations that have been left dormant after the drive process treatment because further hydrocarbon production using the drive process is not possible and/or not economically feasible. In some embodiments, the formation remains at least somewhat preheated from the drive process even after the significant time.

[0136] In some embodiments, heaters are used to preheat the formation for the drive
10 process. For example, heaters may be used to create injectivity in the formation for a drive fluid. The heaters may create high mobility zones (or injection zones) in the formation for the drive process. In certain embodiments, heaters are used to create injectivity in formations with little or no initial injectivity. Heating the formation may create a mobilization geometry or production network in the formation to allow fluids to flow
15 through the formation for the drive process. For example, heaters may be used to create a fluid production network between a horizontal heater and a vertical production well. The heaters used to preheat the formation for the drive process may also be used to provide heat during the drive process.

[0137] FIG. 7 depicts a top view representation of an embodiment for preheating using
20 heaters for the drive process. Injection wells 120 and production wells 106 are substantially vertical wells. Heaters 116 are long substantially horizontal heaters positioned so that the heaters pass in the vicinity of injection wells 120. Heaters 116 intersect the vertical well patterns slightly displaced from the vertical wells.

[0138] The vertical location of heaters 116 with respect to injection wells 120 and
25 production wells 106 depends on, for example, the vertical permeability of the formation. In formations with at least some vertical permeability, injected steam will rise to the top of the permeable layer in the formation. In such formations, heaters 116 may be located near the bottom of hydrocarbon layer 114, as shown in FIG. 9. In formations with very low vertical permeabilities, more than one horizontal heater may be used with the heaters
30 stacked substantially vertically or with heaters at varying depths in the hydrocarbon layer (for example, heater patterns as shown in FIGS. 3-6). The vertical spacing between the horizontal heaters in such formations may correspond to the distance between the heaters and the injection wells. Heaters 116 are located in the vicinity of injection wells 120

and/or production wells 106 so that sufficient energy is delivered by the heaters to provide flow rates for the drive process that are economically viable. The spacing between heaters 116 and injection wells 120 or production wells 106 may be varied to provide an economically viable drive process. The amount of preheating may also be varied to
5 provide an economically viable process.

[0139] In certain embodiments, a fluid is injected into the formation (for example, a drive fluid or an oxidizing fluid) to move hydrocarbons through the formation from a first section to a second section. In some embodiments, the hydrocarbons are moved from the first section to the second section through a third section. FIG. 8 depicts a side view
10 representation of an embodiment using at least three treatment sections in a tar sands formation. Hydrocarbon layer 114 may be divide into three or more treatment sections. In certain embodiments, hydrocarbon layer 114 includes three different types of treatment sections: section 121A, section 121B, and section 121C. Section 121C and sections 121A are separated by sections 121B. Section 121C, sections 121A, and sections 121B may be
15 horizontally displaced from each other in the formation. In some embodiments, one side of section 121C is adjacent to an edge of the treatment area of the formation or an untreated section of the formation is left on one side of section 121C before the same or a different pattern is formed on the opposite side of the untreated section.

[0140] In certain embodiments, sections 121A and 121C are heated at or near the same
20 time to similar temperatures (for example, pyrolysis temperatures). Sections 121A and 121C may be heated to mobilize and/or pyrolyze hydrocarbons in the sections. The mobilized and/or pyrolyzed hydrocarbons may be produced (for example, through one or more production wells) from section 121A and/or section 121C. Section 121B may be heated to lower temperatures (for example, mobilization temperatures). Little or no
25 production of hydrocarbons to the surface may take place through section 121B. For example, sections 121A and 121C may be heated to average temperatures of about 300 °C while section 121B is heated to an average temperature of about 100 °C and no production wells are operated in section 121B.

[0141] In certain embodiments, heating and producing hydrocarbons from section 121C
30 creates fluid injectivity in the section. After fluid injectivity has been created in section 121C, a fluid such as a drive fluid (for example, steam, water, or hydrocarbons) and/or an oxidizing fluid (for example, air, oxygen, enriched oxygen, or other oxidants) may be injected into the section. The fluid may be injected through heaters 116, a production well,

and/or an injection well located in section 121C. In some embodiments, heaters 116 continue to provide heat while the fluid is being injected. In other embodiments, heaters 116 may be turned down or off before or during fluid injection.

[0142] In some embodiments, providing oxidizing fluid such as air to section 121C causes
5 oxidation of hydrocarbons in the section. For example, coked hydrocarbons and/or heated hydrocarbons in section 121C may oxidize if the temperature of the hydrocarbons is above an oxidation ignition temperature. In some embodiments, treatment of section 121C with the heaters creates coked hydrocarbons with substantially uniform porosity and/or substantially uniform injectivity so that heating of the section is controllable when
10 oxidizing fluid is introduced to the section. The oxidation of hydrocarbons in section 121C will maintain the average temperature of the section or increase the average temperature of the section to higher temperatures (for example, about 400 °C or above).

[0143] In some embodiments, injection of the oxidizing fluid is used to heat section 121C and a second fluid is introduced into the formation after or with the oxidizing fluid to
15 create drive fluids in the section. During injection of air, excess air and/or oxidation products may be removed from section 121C through one or more producer wells. After the formation is raised to a desired temperature, a second fluid may be introduced into section 121C to react with coke and/or hydrocarbons and generate drive fluid (for example, synthesis gas). In some embodiments, the second fluid includes water and/or steam.
20 Reactions of the second fluid with carbon in the formation may be endothermic reactions that cool the formation. In some embodiments, oxidizing fluid is added with the second fluid so that some heating of section 121C occurs simultaneous with the endothermic reactions. In some embodiments, section 121C may be treated in alternating steps of adding oxidant to heat the formation, and then adding second fluid to generate drive fluids.

[0144] The generated drive fluids in section 121C may include steam, carbon dioxide,
25 carbon monoxide, hydrogen, methane, and/or pyrolyzed hydrocarbons. The high temperature in section 121C and the generation of drive fluid in the section may increase the pressure of the section so the drive fluids move out of the section into adjacent sections. The increased temperature of section 121C may also provide heat to section 121B through
30 conductive heat transfer and/or convective heat transfer from fluid flow (for example, hydrocarbons and/or drive fluid) to section 121B.

[0145] In some embodiments, hydrocarbons (for example, hydrocarbons produced from section 121C) are provided as a portion of the drive fluid. The injected hydrocarbons may

include at least some pyrolyzed hydrocarbons such as pyrolyzed hydrocarbons produced from section 121C. In some embodiments, steam or water are provided as a portion of the drive fluid. Providing steam or water in the drive fluid may be used to control temperatures in the formation. For example, steam or water may be used to keep
5 temperatures lower in the formation. In some embodiments, water injected as the drive fluid is turned into steam in the formation due to the higher temperatures in the formation. The conversion of water to steam may be used to reduce temperatures or maintain lower temperatures in the formation.

[0146] Fluids injected in section 121C may flow towards section 121B, as shown by the
10 arrows in FIG. 8. Fluid movement through the formation transfers heat convectively through hydrocarbon layer 114 into sections 121B and/or 121A. In addition, some heat may transfer conductively through the hydrocarbon layer between the sections.

[0147] Low level heating of section 121B mobilizes hydrocarbons in the section. The mobilized hydrocarbons in section 121B may be moved by the injected fluid through the
15 section towards section 121A, as shown by the arrows in FIG. 8. Thus, the injected fluid is pushing hydrocarbons from section 121C through section 121B to section 121A.

Mobilized hydrocarbons may be upgraded in section 121A due to the higher temperatures in the section. Pyrolyzed hydrocarbons that move into section 121A may also be further upgraded in the section. The upgraded hydrocarbons may be produced through production
20 wells located in section 121A.

[0148] In certain embodiments, at least some hydrocarbons in section 121B are mobilized and drained from the section prior to injecting the fluid into the formation. Some formations may have high oil saturation (for example, the Grosmont formation has high oil saturation). The high oil saturation corresponds to low gas permeability in the formation
25 that may inhibit fluid flow through the formation. Thus, mobilizing and draining (removing) some oil (hydrocarbons) from the formation may create gas permeability for the injected fluids.

[0149] Fluids in hydrocarbon layer 114 may preferentially move horizontally within the hydrocarbon layer from the point of injection because tar sands tend to have a larger
30 horizontal permeability than vertical permeability. The higher horizontal permeability allows the injected fluid to move hydrocarbons between sections preferentially versus fluids draining vertically due to gravity in the formation. Providing sufficient fluid

pressure with the injected fluid may ensure that fluids are moved to section 121A for upgrading and/or production.

[0150] In certain embodiments, section 121B has a larger volume than section 121A and/or section 121C. Section 121B may be larger in volume than the other sections so that more hydrocarbons are produced for less energy input into the formation. Because less heat is provided to section 121B (the section is heated to lower temperatures), having a larger volume in section 121B reduces the total energy input to the formation per unit volume. The desired volume of section 121B may depend on factors such as, but not limited to, viscosity, oil saturation, and permeability. In addition, the degree of coking is much less in section 121B due to the lower temperature so less hydrocarbons are coked in the formation when section 121B has a larger volume. In some embodiments, the lower degree of heating in section 121B allows for cheaper capital costs as lower temperature materials (cheaper materials) may be used for heaters used in section 121B.

[0151] Some formations with little or no initial injectivity (such as karsted formations or karsted layers in formations) may have tight vugs in one or more layers of the formations. The tight vugs may be vugs filled with viscous fluids such as bitumen or heavy oil. In some embodiments, the vugs have a porosity of at least about 20 porosity units, at least about 30 porosity units, or at least about 35 porosity units. The formation may have a porosity of at most about 15 porosity units, at most about 10 porosity units, or at most about 5 porosity units. The tight vugs inhibit steam or other fluids from being injected into the formation or the layers with tight vugs. In certain embodiments, the karsted formation or karsted layers of the formation are treated using the in situ heat treatment process. Heating of these formations or layers may decrease the viscosity of the fluids in the tight vugs and allow the fluids to drain (for example, mobilize the fluids).

[0152] In certain embodiments, only the karsted layers of the formation are treated using the in situ heat treatment process. Other non-karsted layers of the formation may be used as seals for the in situ heat treatment process.

[0153] In some embodiments, the drive process is used after the in situ heat treatment of the karsted formation or karsted layers. In some embodiments, heaters are used to preheat the karsted formation or karsted layers to create injectivity in the formation.

[0154] In certain embodiments, the karsted formation or karsted layers are heated to temperatures below the decomposition temperature of rock (for example, dolomite) in the formation (for example, temperatures of at most about 400 °C). In some embodiments, the

karsted formation or karsted layers are heated to temperatures above the decomposition temperature of dolomite in the formation. At temperatures above the dolomite decomposition temperature, the dolomite may decompose to produce carbon dioxide. The decomposition of the dolomite and the carbon dioxide production may create permeability
5 in the formation and mobilize viscous fluids in the formation. In some embodiments, the produced carbon dioxide is maintained in the formation to produce a gas cap in the formation. The carbon dioxide may be allowed to rise to the upper portions of the karsted layers to produce the gas cap.

[0155] In some embodiments, heaters are used to produce and/or maintain the gas cap in
10 the formation for the in situ heat treatment process and/or the drive process. The gas cap may drive fluids from upper portions to lower portions of the formation and/or from portions of the formation towards portions of the formation at lower pressures (for example, portions with production wells). In some embodiments, little or no heating is provided in the portions of the formation with the gas cap. In some embodiments, heaters
15 in the gas cap are turned down and/or off after formation of the gas cap. Using less heating in the gas cap may reduce the energy input into the formation and increase the efficiency of the in situ heat treatment process and/or the drive process. In some embodiments, production wells and/or heater wells that are located in the gas cap portion of the formation may be used for injection of fluid (for example, steam) to maintain the gas cap.

[0156] In some embodiments, the production front of the drive process follows behind the
20 heat front of the in situ heat treatment process. In some embodiments, areas behind the production front are further heated to produce more fluids from the formation. Further heating behind the production front may also maintain the gas cap behind the production front and/or maintain quality in the production front of the drive process.

[0157] In certain embodiments, the drive process is used before the in situ heat treatment
25 of the formation. In some embodiments, the drive process is used to mobilize fluids in a first section of the formation. The mobilized fluids may then be pushed into a second section by heating the first section with heaters. Fluids may be produced from the second section. In some embodiments, the fluids in the second section are pyrolyzed and/or
30 upgraded using the heaters.

[0158] In formations with low permeabilities, the drive process may be used to create a
“gas cushion” or pressure sink before the in situ heat treatment process. The gas cushion may inhibit pressures from increasing quickly to fracture pressure during the in situ heat

treatment process. The gas cushion may provide a path for gases to escape or travel during early stages of heating during the in situ heat treatment process.

[0159] In some embodiments, the drive process (for example, the steam injection process) is used to mobilize fluids before the in situ heat treatment process. Steam injection may be used to get hydrocarbons (oil) away from rock or other strata in the formation. The steam injection may mobilize the oil without significantly heating the rock.

[0160] In some embodiments, injection of a fluid (for example, steam or carbon dioxide) may consume heat in the formation and cool the formation depending on the pressure in the formation. In some embodiments, the injected fluid is used to recover heat from the formation. The recovered heat may be used in surface processing of fluids and/or to preheat other portions of the formation using the drive process.

Examples

[0161] Non-restrictive examples are set forth below.

15 *Tar Sands Simulation*

[0162] A STARS simulation was used to simulate heating of a tar sands formation using the heater well pattern depicted in FIG. 3. The heaters had a horizontal length in the tar sands formation of 600 m. The heating rate of the heaters was about 750 W/m. Production well 106B, depicted in FIG. 3, was used at the production well in the simulation. The bottom hole pressure in the horizontal production well was maintained at about 690 kPa. The tar sands formation properties were based on Athabasca tar sands. Input properties for the tar sands formation simulation included: initial porosity equals 0.28; initial oil saturation equals 0.8; initial water saturation equals 0.2; initial free gas saturation equals 0.0; initial vertical permeability equals 250 millidarcy; initial horizontal permeability equals 500 millidarcy; initial Kv/Kh equals 0.5; hydrocarbon layer thickness equals 28 m; depth of hydrocarbon layer equals 587 m; initial reservoir pressure equals 3771 kPa; distance between production well and lower boundary of hydrocarbon layer equals 2.5 meter; distance of topmost heaters and overburden equals 9 meter; spacing between heaters equals 9.5 meter; initial hydrocarbon layer temperature equals 18.6 °C; viscosity at initial temperature equals 53 Pa·s (53000 cp); and gas to oil ratio (GOR) in the tar equals 50 standard cubic feet/standard barrel. The heaters were constant wattage heaters with a

highest temperature of 538 °C at the sand face and a heater power of 755 W/m. The heater wells had a diameter of 15.2 cm.

[0163] FIG. 10 depicts a temperature profile in the formation after 360 days using the STARS simulation. The hottest spots are at or near heaters 116. The temperature profile shows that portions of the formation between the heaters are warmer than other portions of the formation. These warmer portions create more mobility between the heaters and create a flow path for fluids in the formation to drain downwards towards the production wells.

[0164] FIG. 11 depicts an oil saturation profile in the formation after 360 days using the STARS simulation. Oil saturation is shown on a scale of 0.00 to 1.00 with 1.00 being 100% oil saturation. The oil saturation scale is shown in the sidebar. Oil saturation, at 360 days, is somewhat lower at heaters 116 and production well 106B. FIG. 12 depicts the oil saturation profile in the formation after 1095 days using the STARS simulation. Oil saturation decreased overall in the formation with a greater decrease in oil saturation near the heaters and in between the heaters after 1095 days. FIG. 13 depicts the oil saturation profile in the formation after 1470 days using the STARS simulation. The oil saturation profile in FIG. 13 shows that the oil is mobilized and flowing towards the lower portions of the formation. FIG. 14 depicts the oil saturation profile in the formation after 1826 days using the STARS simulation. The oil saturation is low in a majority of the formation with some higher oil saturation remaining at or near the bottom of the formation in portions below production well 106B. This oil saturation profile shows that a majority of oil in the formation has been produced from the formation after 1826 days.

[0165] FIG. 15 depicts the temperature profile in the formation after 1826 days using the STARS simulation. The temperature profile shows a relatively uniform temperature profile in the formation except at heaters 116 and in the extreme (corner) portions of the formation. The temperature profile shows that a flow path has been created between the heaters and to production well 106B.

[0166] FIG. 16 depicts oil production rate 122 (bbl/day)(left axis) and gas production rate 124 (ft³/day)(right axis) versus time (years). The oil production and gas production plots show that oil is produced at early stages (0-1.5 years) of production with little gas production. The oil produced during this time was most likely heavier mobilized oil that is unpyrolyzed. After about 1.5 years, gas production increased sharply as oil production decreased sharply. The gas production rate quickly decreased at about 2 years. Oil

production then slowly increased up to a maximum production around about 3.75 years. Oil production then slowly decreased as oil in the formation was depleted.

[0167] From the STARS simulation, the ratio of energy out (produced oil and gas energy content) versus energy in (heater input into the formation) was calculated to be about 12 to 1 after about 5 years. The total recovery percentage of oil in place was calculated to be about 60% after about 5 years. Thus, producing oil from a tar sands formation using an embodiment of the heater and production well pattern depicted in FIG. 3 may produce high oil recoveries and high energy out to energy in ratios.

Tar Sands Example

[0168] A STARS simulation was used in combination with experimental analysis to simulate an in situ heat treatment process of a tar sands formation. Heating conditions for the experimental analysis were determined from reservoir simulations. The experimental analysis included heating a cell of tar sands from the formation to a selected temperature and then reducing the pressure of the cell (blow down) to 100 psig. The process was repeated for several different selected temperatures. While heating the cells, formation and fluid properties of the cells were monitored while producing fluids to maintain the pressure below an optimum pressure of 12 MPa before blow down and while producing fluids after blow down (although the pressure may have reached higher pressures in some cases, the pressure was quickly adjusted and does not affect the results of the experiments). FIGS. 17-24 depict results from the simulation and experiments.

[0169] FIG. 17 depicts weight percentage of original bitumen in place (OBIP)(left axis) and volume percentage of OBIP (right axis) versus temperature (°C). The term "OBIP" refers, in these experiments, to the amount of bitumen that was in the laboratory vessel with 100% being the original amount of bitumen in the laboratory vessel. Plot 126 depicts bitumen conversion (correlated to weight percentage of OBIP). Plot 126 shows that bitumen conversion began to be significant at about 270 °C and ended at about 340 °C and is relatively linear over the temperature range.

[0170] Plot 128 depicts barrels of oil equivalent from producing fluids and production at blow down (correlated to volume percentage of OBIP). Plot 130 depicts barrels of oil equivalent from producing fluids (correlated to volume percentage of OBIP). Plot 132 depicts oil production from producing fluids (correlated to volume percentage of OBIP). Plot 134 depicts barrels of oil equivalent from production at blow down (correlated to

volume percentage of OBIP). Plot 136 depicts oil production at blow down (correlated to volume percentage of OBIP). As shown in FIG. 17, the production volume began to significantly increase as bitumen conversion began at about 270 °C with a significant portion of the oil and barrels of oil equivalent (the production volume) coming from producing fluids and only some volume coming from the blow down.

[0171] FIG. 18 depicts bitumen conversion percentage (weight percentage of (OBIP))(left axis) and oil, gas, and coke weight percentage (as a weight percentage of OBIP)(right axis) versus temperature (°C). Plot 138 depicts bitumen conversion (correlated to weight percentage of OBIP). Plot 140 depicts oil production from producing fluids correlated to weight percentage of OBIP (right axis). Plot 142 depicts coke production correlated to weight percentage of OBIP (right axis). Plot 144 depicts gas production from producing fluids correlated to weight percentage of OBIP (right axis). Plot 146 depicts oil production from blow down production correlated to weight percentage of OBIP (right axis). Plot 148 depicts gas production from blow down production correlated to weight percentage of OBIP (right axis). FIG. 18 shows that coke production begins to increase at about 280 °C and maximizes around 340 °C. FIG. 18 also shows that the majority of oil and gas production is from produced fluids with only a small fraction from blow down production.

[0172] FIG. 19 depicts API gravity (°)(left axis) of produced fluids, blow down production, and oil left in place along with pressure (psig)(right axis) versus temperature (°C). Plot 150 depicts API gravity of produced fluids versus temperature. Plot 152 depicts API gravity of fluids produced at blow down versus temperature. Plot 154 depicts pressure versus temperature. Plot 156 depicts API gravity of oil (bitumen) in the formation versus temperature. FIG. 19 shows that the API gravity of the oil in the formation remains relatively constant at about 10° API and that the API gravity of produced fluids and fluids produced at blow down increases slightly at blow down.

[0173] FIGS. 20A-D depict gas-to-oil ratios (GOR) in thousand cubic feet per barrel ((Mcf/ bbl)(y-axis) versus temperature (°C)(x-axis) for different types of gas at a low temperature blow down (about 277 °C) and a high temperature blow down (at about 290 °C). FIG. 20A depicts the GOR versus temperature for carbon dioxide (CO₂). Plot 158 depicts the GOR for the low temperature blow down. Plot 160 depicts the GOR for the high temperature blow down. FIG. 20B depicts the GOR versus temperature for hydrocarbons. FIG. 20C depicts the GOR for hydrogen sulfide (H₂S). FIG. 20D depicts the GOR for hydrogen (H₂). In FIGS. 20B-D, the GORs were approximately the same for

both the low temperature and high temperature blow downs. The GORs for CO₂ (shown in FIG. 20) was different for the high temperature blow down and the low temperature blow down. The reason for the difference in the GORs for CO₂ may be that CO₂ was produced early (at low temperatures) by the hydrous decomposition of dolomite and other carbonate minerals and clays. At these low temperatures, there was hardly any produced oil so the GOR is very high because the denominator in the ratio is practically zero. The other gases (hydrocarbons, H₂S, and H₂) were produced concurrently with the oil either because they were all generated by the upgrading of bitumen (for example, (hydrocarbons, H₂, and oil) or because they were generated by the decomposition of minerals (such as pyrite) in the same temperature range as that of bitumen upgrading (for example, H₂S). Thus, when the GOR was calculated, the denominator (oil) was non zero for hydrocarbons, H₂S, and H₂. [0174] FIG. 21 depicts coke yield (weight percentage)(y-axis) versus temperature (°C)(x-axis). Plot 162 depicts bitumen and kerogen coke as a weight percent of original mass in the formation. Plot 164 depicts bitumen coke as a weight percent of original bitumen in place (OBIP) in the formation. FIG. 21 shows that kerogen coke is already present at a temperature of about 260 °C (the lowest temperature cell experiment) while bitumen coke begins to form at about 280 °C and maximizes at about 340 °C.

[0175] FIGS. 22A-D depict assessed hydrocarbon isomer shifts in fluids produced from the experimental cells as a function of temperature and bitumen conversion. Bitumen conversion and temperature increase from left to right in the plots in FIGS. 22A-D with the minimum bitumen conversion being 10%, the maximum bitumen conversion being 100%, the minimum temperature being 277 °C, and the maximum temperature being 350 °C. The arrows in FIGS. 22A-D show the direction of increasing bitumen conversion and temperature.

[0176] FIG. 22A depicts the hydrocarbon isomer shift of n-butane- $\delta^{13}\text{C}_4$ percentage (y-axis) versus propane- $\delta^{13}\text{C}_3$ percentage (x-axis). FIG. 22B depicts the hydrocarbon isomer shift of n-pentane- $\delta^{13}\text{C}_5$ percentage (y-axis) versus propane- $\delta^{13}\text{C}_3$ percentage (x-axis). FIG. 22C depicts the hydrocarbon isomer shift of n-pentane- $\delta^{13}\text{C}_5$ percentage (y-axis) versus n-butane- $\delta^{13}\text{C}_4$ percentage (x-axis). FIG. 22D depicts the hydrocarbon isomer shift of i-pentane- $\delta^{13}\text{C}_5$ percentage (y-axis) versus i-butane- $\delta^{13}\text{C}_4$ percentage (x-axis). FIGS. 22A-D show that there is a relatively linear relationship between the hydrocarbon isomer shifts and both temperature and bitumen conversion. The relatively linear relationship may

be used to assess formation temperature and/or bitumen conversion by monitoring the hydrocarbon isomer shifts in fluids produced from the formation.

[0177] FIG. 23 depicts weight percentage (Wt%)(y-axis) of saturates from SARA analysis of the produced fluids versus temperature ($^{\circ}\text{C}$)(x-axis). The logarithmic relationship

5 between the weight percentage of saturates and temperature may be used to assess formation temperature by monitoring the weight percentage of saturates in fluids produced from the formation.

[0178] FIG. 24 depicts weight percentage (Wt%)(y-axis) of n-C₇ of the produced fluids versus temperature ($^{\circ}\text{C}$)(x-axis). The linear relationship between the weight percentage of

10 n-C₇ and temperature may be used to assess formation temperature by monitoring the weight percentage of n-C₇ in fluids produced from the formation.

Pre-Heating Using Heaters For Injectivity Before Steam Drive Example

[0179] An example uses the embodiment depicted in FIGS. 7 and 9 to preheat using heaters for the drive process is described. Injection wells 120 and production wells 106 are

15 substantially vertical wells. Heaters 116 are long substantially horizontal heaters positioned so that the heaters pass in the vicinity of injection wells 120. Heaters 116 intersect the vertical well patterns slightly displaced from the vertical wells.

[0180] The following conditions were assumed for purposes of this example:

- (a) heater well spacing; $s = 330$ ft;
- 20 (b) formation thickness; $h = 100$ ft;
- (c) formation heat capacity; $\rho c = 35$ BTU/cu. ft.- $^{\circ}\text{F}$
- (d) formation thermal conductivity; $\lambda = 1.2$ BTU/ft-hr- $^{\circ}\text{F}$;
- (e) electric heating rate; $q_h = 200$ watts/ft;
- (f) steam injection rate; $q_s = 500$ bbls/day;
- 25 (g) enthalpy of steam; $h_s = 1000$ BTU/lb;
- (h) time of heating; $t = 1$ year;
- (i) total electric heat injection; $Q_E = \text{BTU}/\text{pattern}/\text{year}$;
- (j) radius of electric heat; $r = \text{ft}$; and
- (k) total steam heat injected; $Q_s = \text{BTU}/\text{pattern}/\text{year}$.

30 [0181] Electric heating for one well pattern for one year is given by:

(EQN. 1) $Q_E = q_h \cdot t \cdot s$ (BTU/pattern/year);

with $Q_E = (200 \text{ watts/ft})[0.001 \text{ kw/watt}](1 \text{ yr})[365 \text{ day/yr}][24 \text{ hr/day}][3413 \text{ BTU/kw}\cdot\text{hr}](330 \text{ ft}) = 1.9733 \times 10^9 \text{ BTU/pattern/year}$.

[0182] Steam heating for one well pattern for one year is given by:

(EQN. 2) $Q_s = q_s \cdot t \cdot h_s \text{ (BTU/pattern/year)}$;

5 with $Q_s = (500 \text{ bbls/day})(1 \text{ yr}) [365 \text{ day/yr}][1000 \text{ BTU/lb}][350 \text{ lbs/bbl}] = 63.875 \times 10^9 \text{ BTU/pattern/year}$.

[0183] Thus, electric heat divided by total heat is given by:

(EQN. 3) $Q_E/(Q_E+Q_s) \times 100 = 3\%$ of the total heat.

10 [0184] Thus, the electrical energy is only a small fraction of the total heat injected into the formation.

[0185] The actual temperature of the region around a heater is described by an exponential integral function. The integrated form of the exponential integral function shows that about half the energy injected is nearly equal to about half of the injection well temperature. The temperature required to reduce viscosity of the heavy oil is assumed to be 500 °F. The volume heated to 500 °F by an electric heater in one year is give by:

(EQN. 4) $V_E = \pi r^2$.

[0186] The heat balance is given by:

(EQN. 5) $Q_E = (\pi r_E^2)(s)(\rho c)(\Delta T)$.

20 [0187] Thus, r_E can be solved for and is found to be 10.4 ft. For an electric heater operated at 1000 °F, the diameter of a cylinder heated to half that temperature for one year would be about 23 ft. Depending on the permeability profile in the injection wells, additional horizontal wells may be stacked above the one at the bottom of the formation and/or periods of electric heating may be extended. For a ten year heating period, the diameter of the region heated above 500 °F would be about 60 ft.

25 [0188] If all the steam were injected uniformly into the steam injectors over the 100 ft. interval for a period of one year, the equivalent volume of formation that could be heated to 500 °F would be given by:

(EQN. 6) $Q_s = (\pi r_s^2)(s)(\rho c)(\Delta T)$.

30 [0189] Solve for r_s give an r_s of 107 ft. This amount of heat would be sufficient to heat about $\frac{3}{4}$ of the pattern to 500 °F.

Tar Sands Oil Recovery Example

[0190] A STARS simulation was used in combination with experimental analysis to simulate an in situ heat treatment process of a tar sands formation. The experiments and simulations were used to determine oil recovery (measured by volume percentage (vol%) of oil in place (bitumen in place) versus API gravity of the produced fluid as affected by pressure in the formation. The experiments and simulations also were used to determine recovery efficiency (percentage of oil (bitumen) recovered) versus temperature at different pressures.

[0191] FIG. 25 depicts oil recovery (volume percentage bitumen in place (vol% BIP)) versus API gravity ($^{\circ}$) as determined by the pressure (MPa) in the formation. As shown in FIG. 25, oil recovery decreases with increasing API gravity and increasing pressure up to a certain pressure (about 2.9 MPa in this experiment). Above that pressure, oil recovery and API gravity decrease with increasing pressure (up to about 10 MPa in the experiment). Thus, it may be advantageous to control the pressure in the formation below a selected value to get higher oil recovery along with a desired API gravity in the produced fluid.

[0192] FIG. 26 depicts recovery efficiency (%) versus temperature ($^{\circ}$ C) at different pressures. Curve 166 depicts recovery efficiency versus temperature at 0 MPa. Curve 168 depicts recovery efficiency versus temperature at 0.7 MPa. Curve 170 depicts recovery efficiency versus temperature at 5 MPa. Curve 172 depicts recovery efficiency versus temperature at 10 MPa. As shown by these curves, increasing the pressure reduces the recovery efficiency in the formation at pyrolysis temperatures (temperatures above about 300 $^{\circ}$ C in the experiment). The effect of pressure may be reduced by reducing the pressure in the formation at higher temperatures, as shown by curve 174. Curve 174 depicts recovery efficiency versus temperature with the pressure being 5 MPa up until about 380 $^{\circ}$ C, when the pressure is reduced to 0.7 MPa. As shown by curve 174, the recovery efficiency can be increased by reducing the pressure even at higher temperatures. The effect of higher pressures on the recovery efficiency is reduced when the pressure is reduced before hydrocarbons (oil) in the formation have been converted to coke.

[0193] Further modifications and alternative embodiments of various aspects of the invention may be apparent to those skilled in the art in view of this description.

Accordingly, this description is to be construed as illustrative only and is for the purpose of teaching those skilled in the art the general manner of carrying out the invention. It is to be understood that the forms of the invention shown and described herein are to be taken as

the presently preferred embodiments. Elements and materials may be substituted for those illustrated and described herein, parts and processes may be reversed, and certain features of the invention may be utilized independently, all as would be apparent to one skilled in the art after having the benefit of this description of the invention. Changes may be made
5 in the elements described herein without departing from the spirit and scope of the invention as described in the following claims. In addition, it is to be understood that features described herein independently may, in certain embodiments, be combined.

CLAIMS

1. A method for treating a tar sands formation, comprising:
 - heating a first portion of a hydrocarbon layer in the formation from one or more
 - 5 heaters located in the first portion;
 - controlling the heating to increase a fluid injectivity of the first portion;
 - injecting and/or creating a drive fluid and/or an oxidizing fluid in the first portion to
 - cause at least some hydrocarbons to move from a second portion of the hydrocarbon layer
 - to a third portion of the hydrocarbon layer, the second portion being between the first
 - 10 portion and the third portion, and the first, second, and third portions being horizontally
 - displaced from each other;
 - heating the third portion from one or more heaters located in the third portion; and
 - producing hydrocarbons from the third portion of the formation, the hydrocarbons
 - including at least some hydrocarbons from the second portion of the formation.
- 15 2. The method of claim 1, wherein the drive fluid and/or the oxidizing fluid comprise steam, water, carbon dioxide, carbon monoxide, methane, pyrolyzed hydrocarbons, and/or air.
3. The method of any of claims 1 or 2, further comprising providing heat to the second portion that is less than the heat provided to the first portion and less than the heat provided
- 20 to the third portion.
4. The method of any of claims 1-3, further comprising providing heat to the second portion so that an average temperature of the second portion is at most 100 °C.
5. The method of any of claims 1-4, further comprising providing heat to the third portion so that an average temperature of the third portion is at least 270 °C.
- 25 6. The method of any of claims 1-5, further comprising providing heat to the first portion to produce coke in the first portion.
7. The method of any of claims 1-6, further comprising providing the oxidizing fluid to oxidize at least some hydrocarbons and/or coke in the first portion and increase the temperature in the first portion, and removing the oxidation products from the first portion.
- 30 8. The method of any of claims 1-7, further comprising providing the oxidizing fluid to oxidize at least some hydrocarbons and/or coke in the first portion and increase the temperature in the first portion and, then, adding steam to the first portion to heat the steam and drive fluids to the second and third portions.

9. The method of any of claims 1-8, wherein the formation has a horizontal permeability that is higher than a vertical permeability so that the moving hydrocarbons move substantially horizontally through the formation.
10. The method of any of claims 1-9, wherein the second portion has a larger volume than the first portion and/or the third portion.
11. The method of any of claims 1-10, further comprising providing heat to the third portion such that at least some hydrocarbons from the second portion are pyrolyzed in the third portion.
12. The method of any of claims 1-11, further comprising causing at least some hydrocarbons to move from the first portion to the third portion.
13. The method of any of claims 1-12, wherein the first portion has a substantially uniform porosity and/or a substantially uniform injectivity after heating.
14. The method of any of claims 1-13, wherein at least some of the heaters in the first portion are turned down and/or off after increasing the fluid injectivity in the first portion.
15. The method of any of claims 1-14, wherein the first portion has little or no initial injectivity.
16. The method of any of claims 1-15, further comprising controlling the temperature and the pressure in the first portion and/or the third portion such that (a) at least a majority of the hydrocarbons in the first portion and/or the third portion are visbroken, (b) the pressure is below the fracture pressure of the first portion and/or the third portion, and (c) at least some hydrocarbons in the first portion and/or the third portion form a fluid comprising visbroken hydrocarbons that can be produced through a production well.
17. The method of any of claims 1-16, further comprising mobilizing at least some hydrocarbons in the second portion using heat provided from heaters located in the second portion, heat transferred from the first portion, and/or heat transferred from the third portion.
18. The method of any of claims 1-17, further comprising using the produced fluids to make a transportation fuel.
19. A transportation fluid made using the method of claim 18.

1 / 21

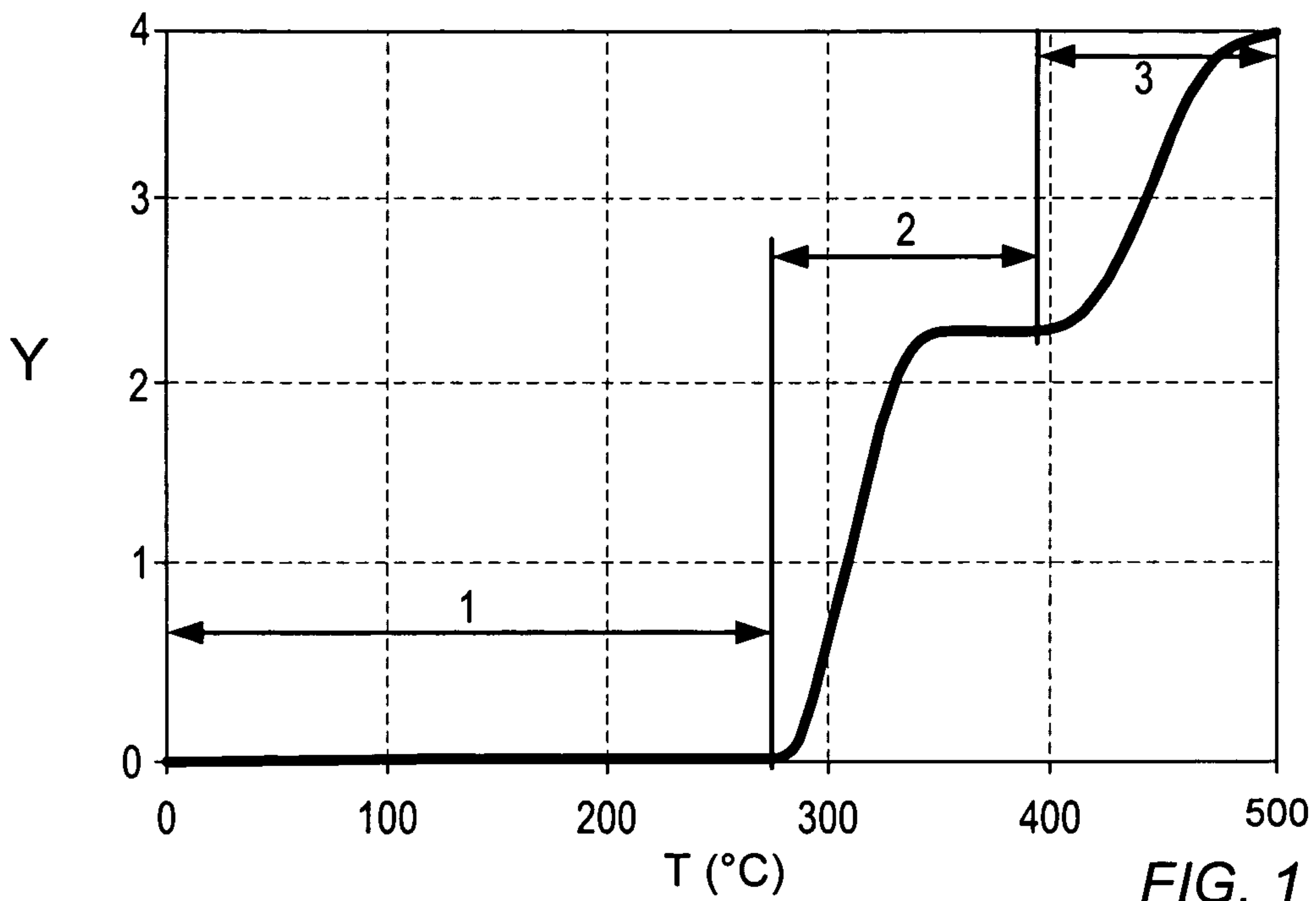

FIG. 1

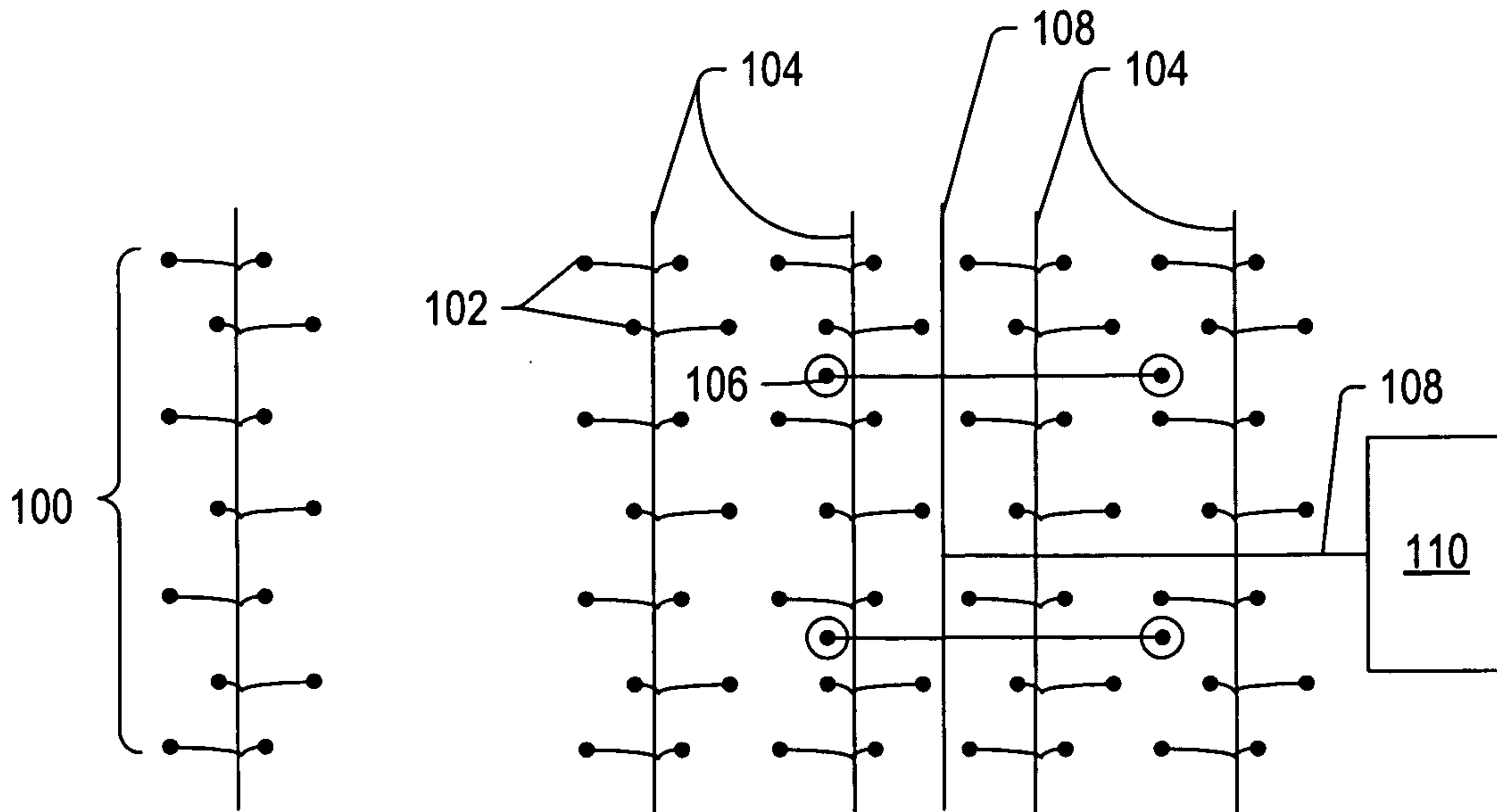

FIG. 2

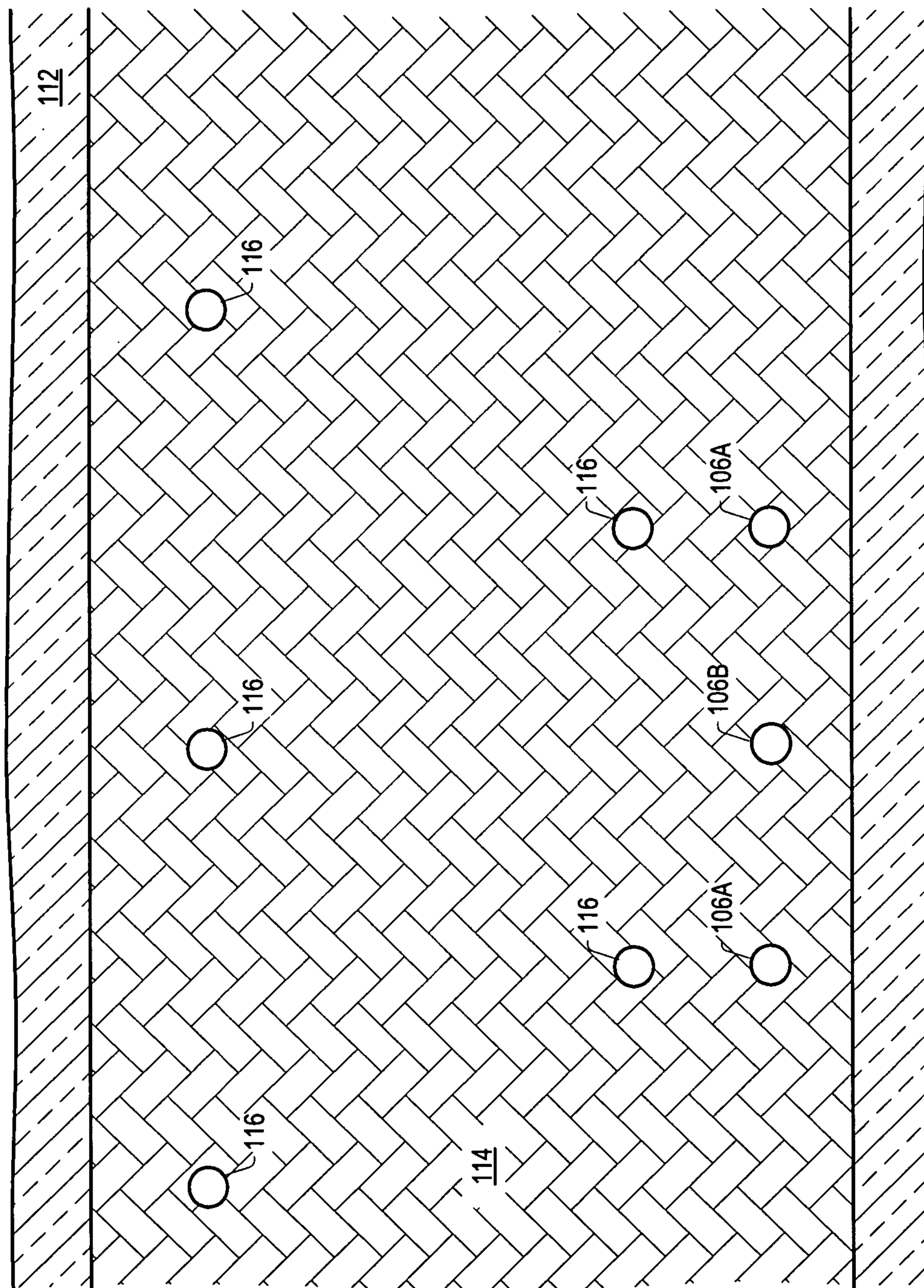

FIG. 3

3/21

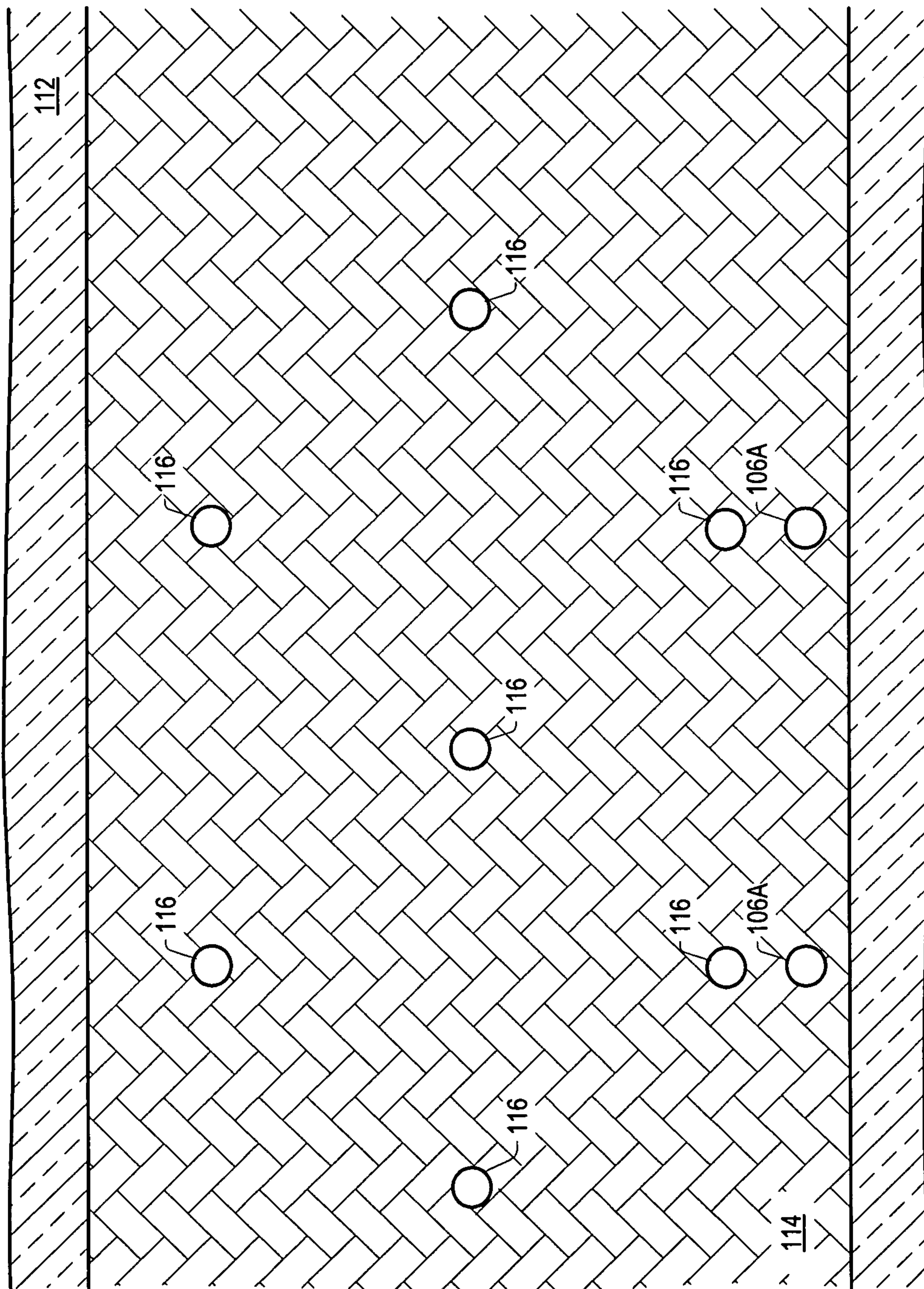

FIG. 4

4/21

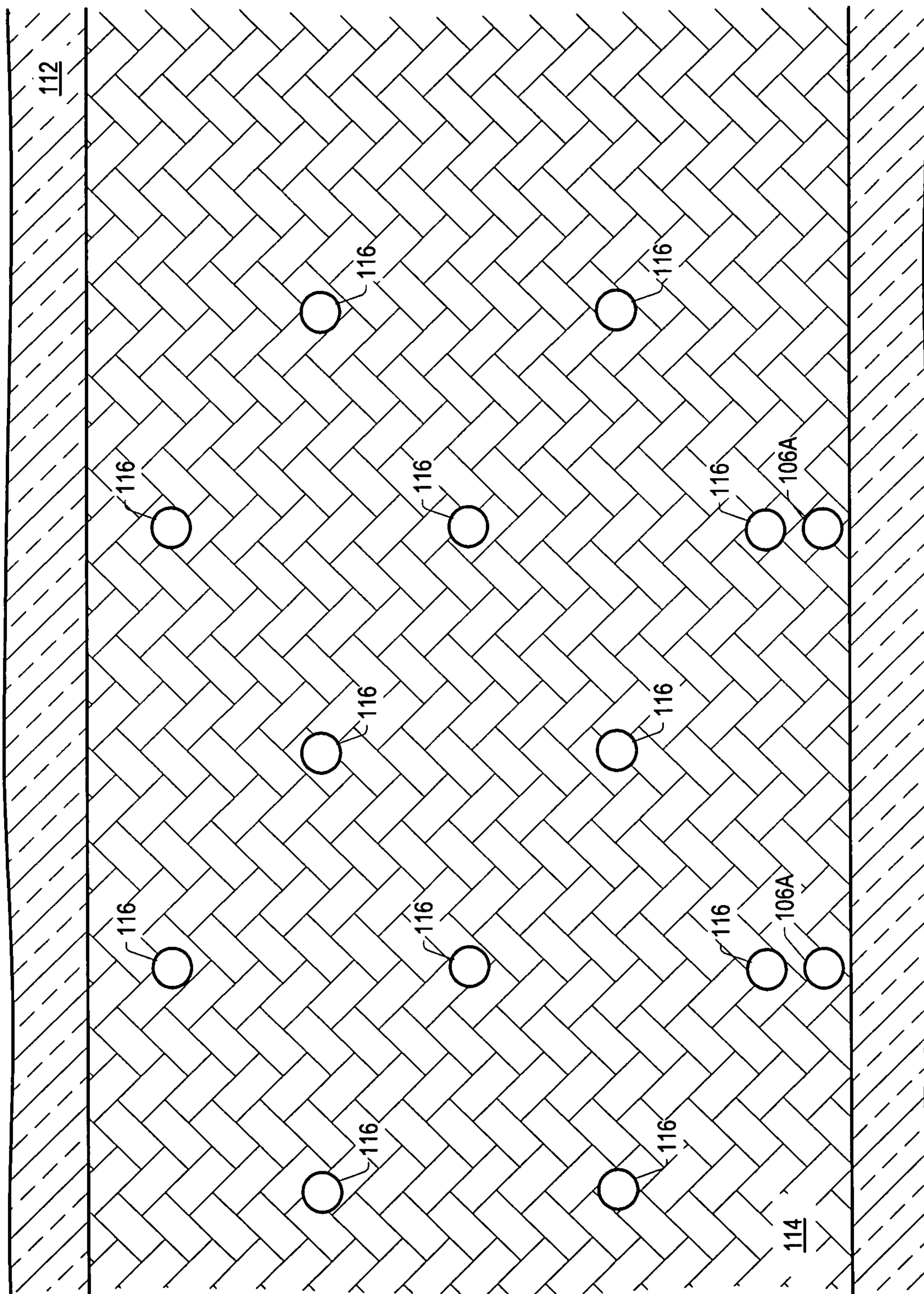

FIG. 5

5/21

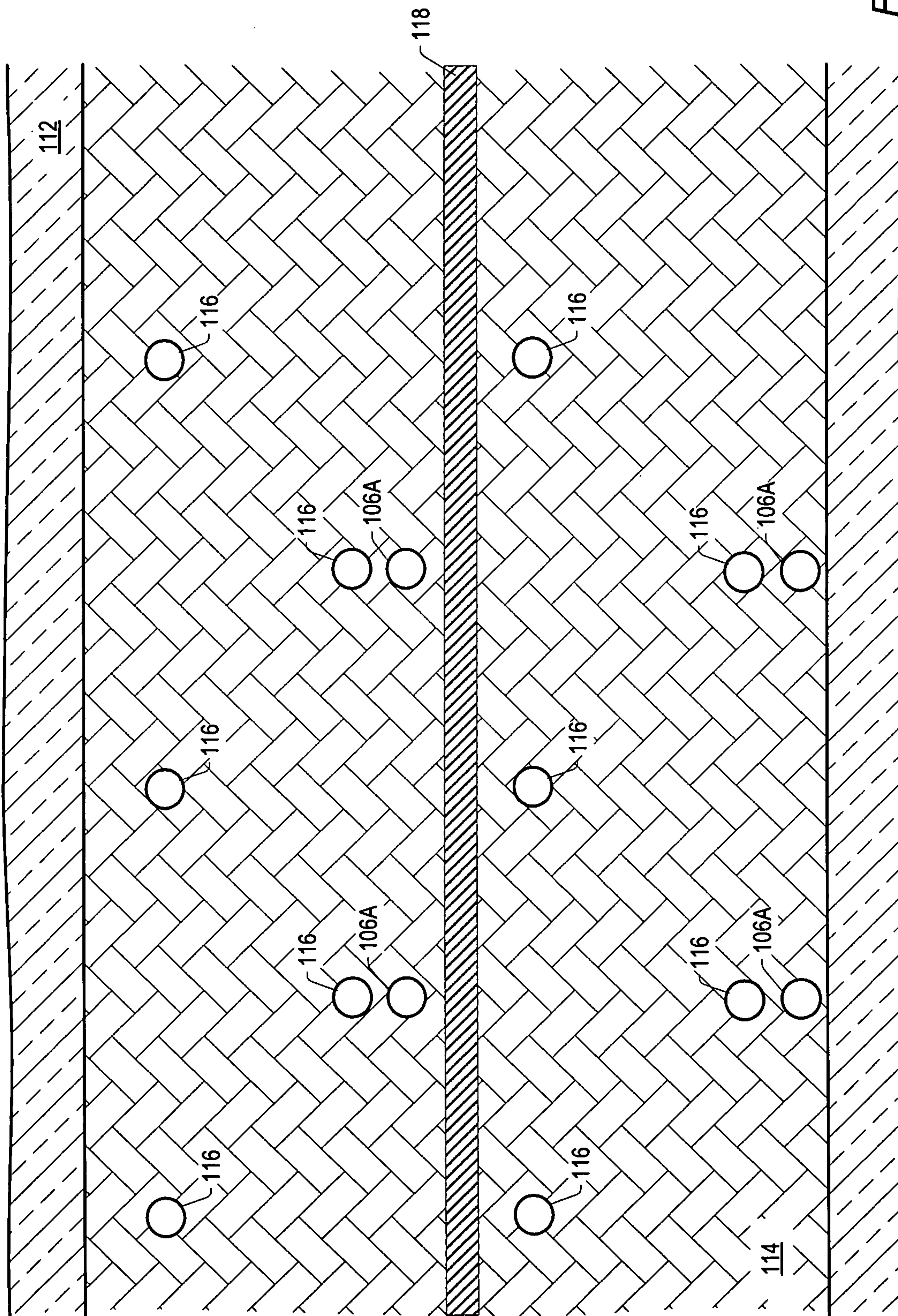

FIG. 6

6/21

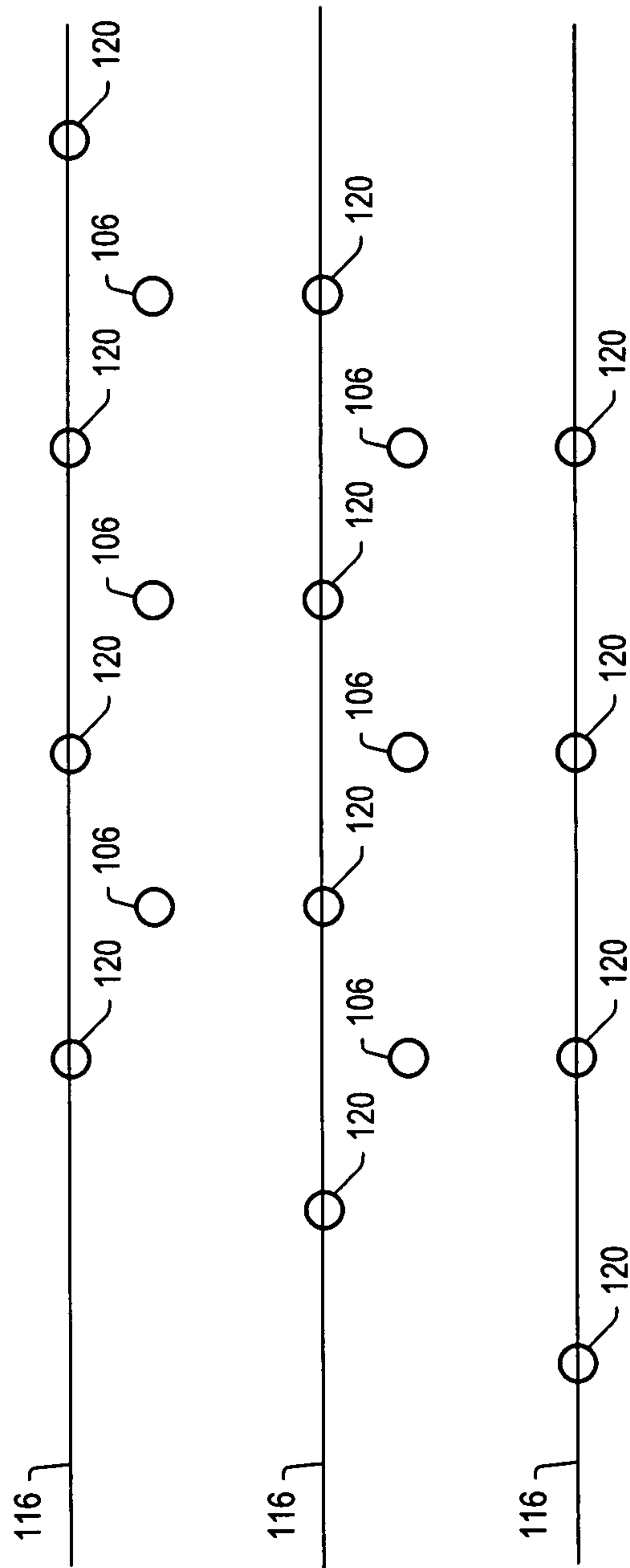

FIG. 7

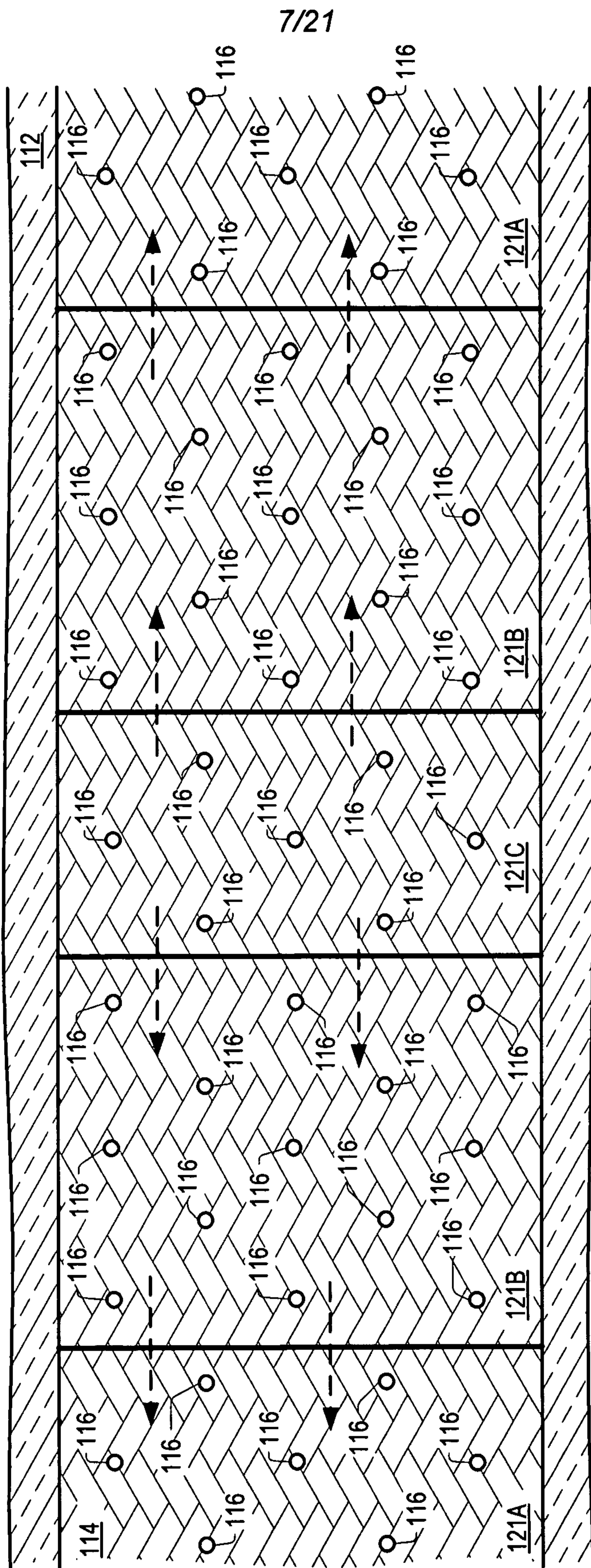
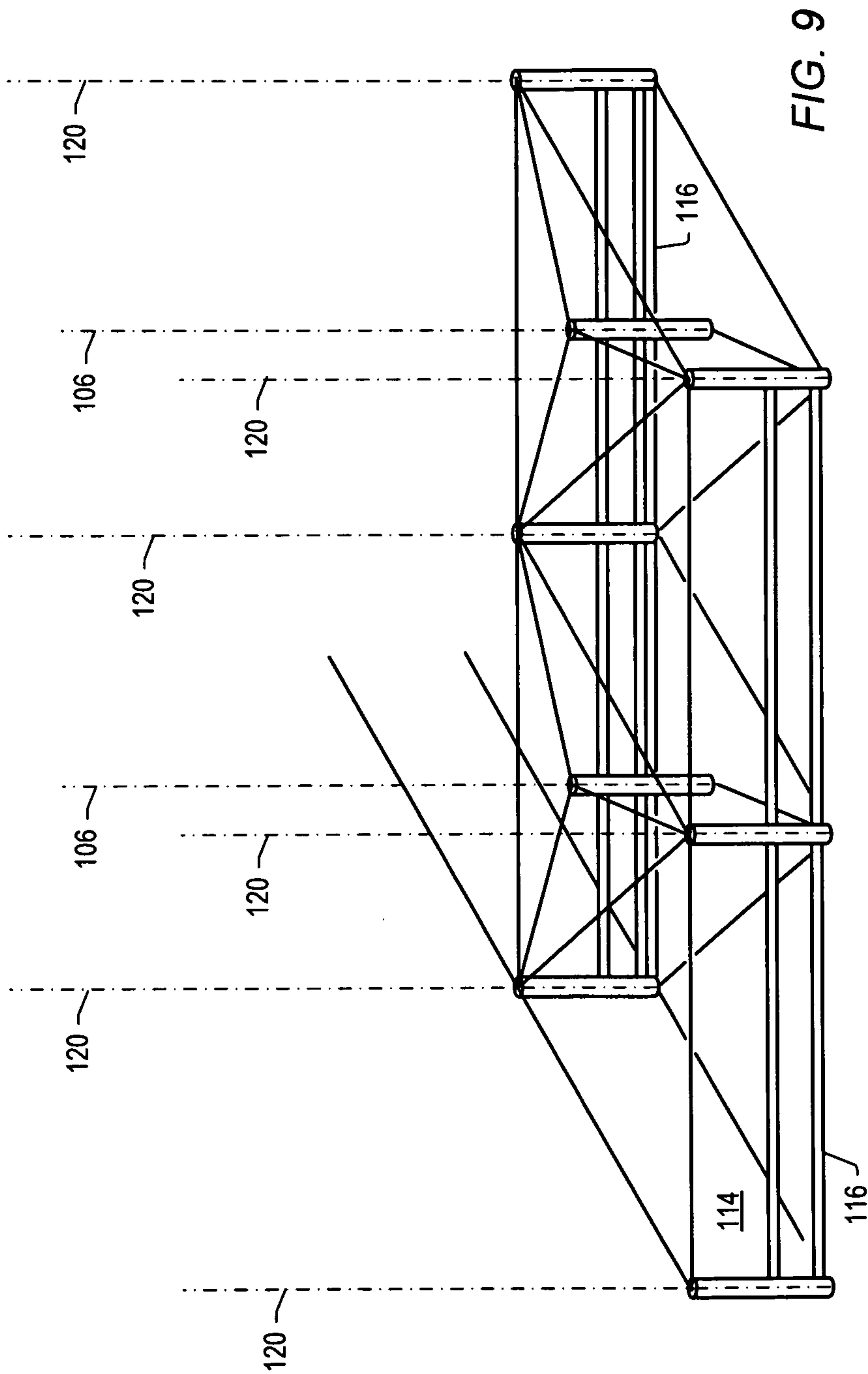

FIG. 8

8/21



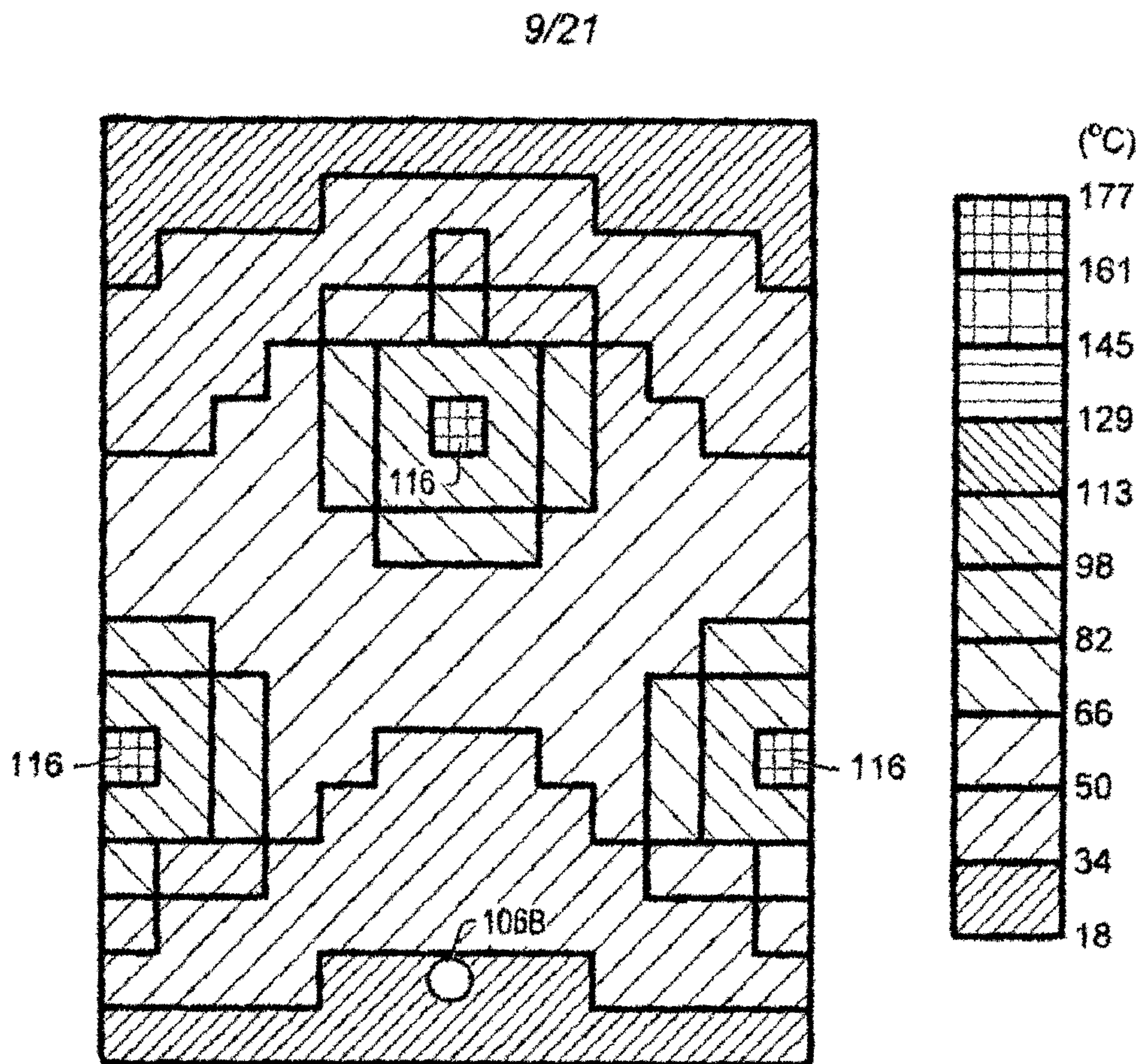
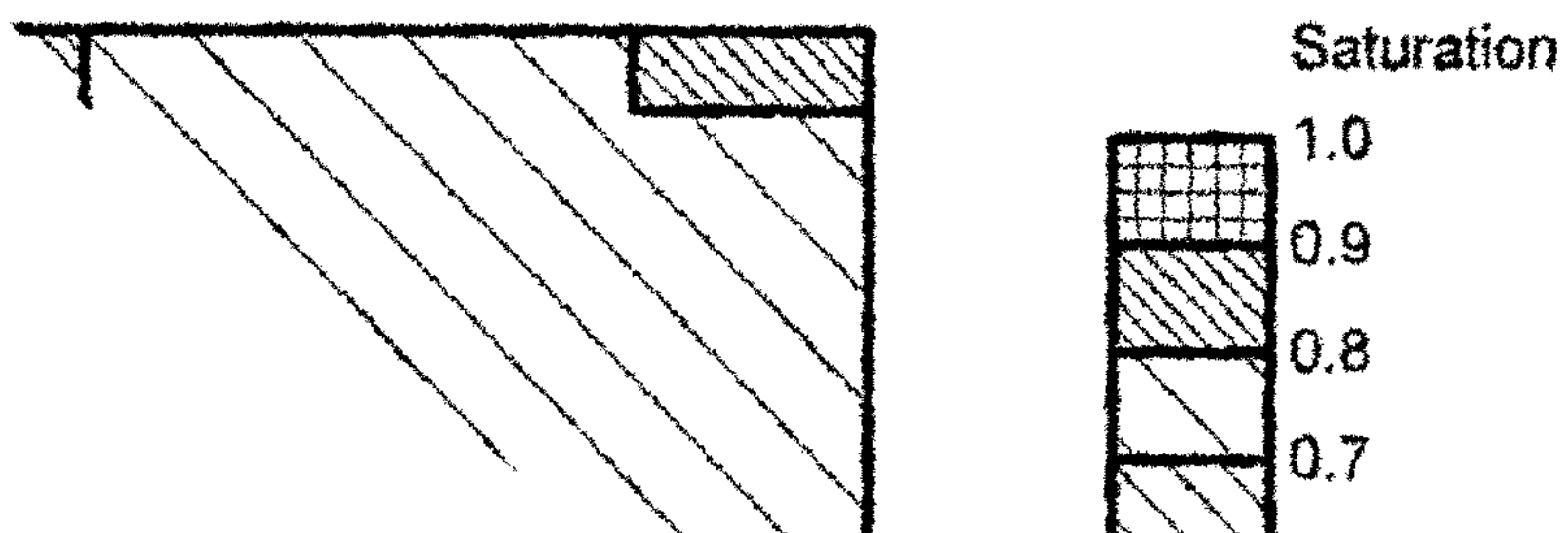

FIG. 10



10/21

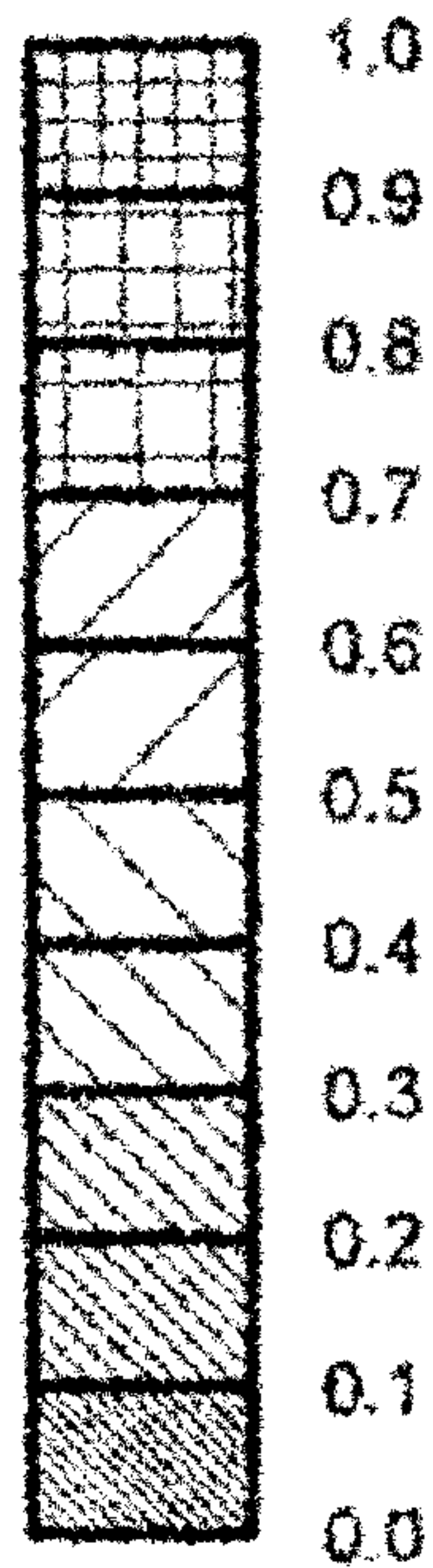
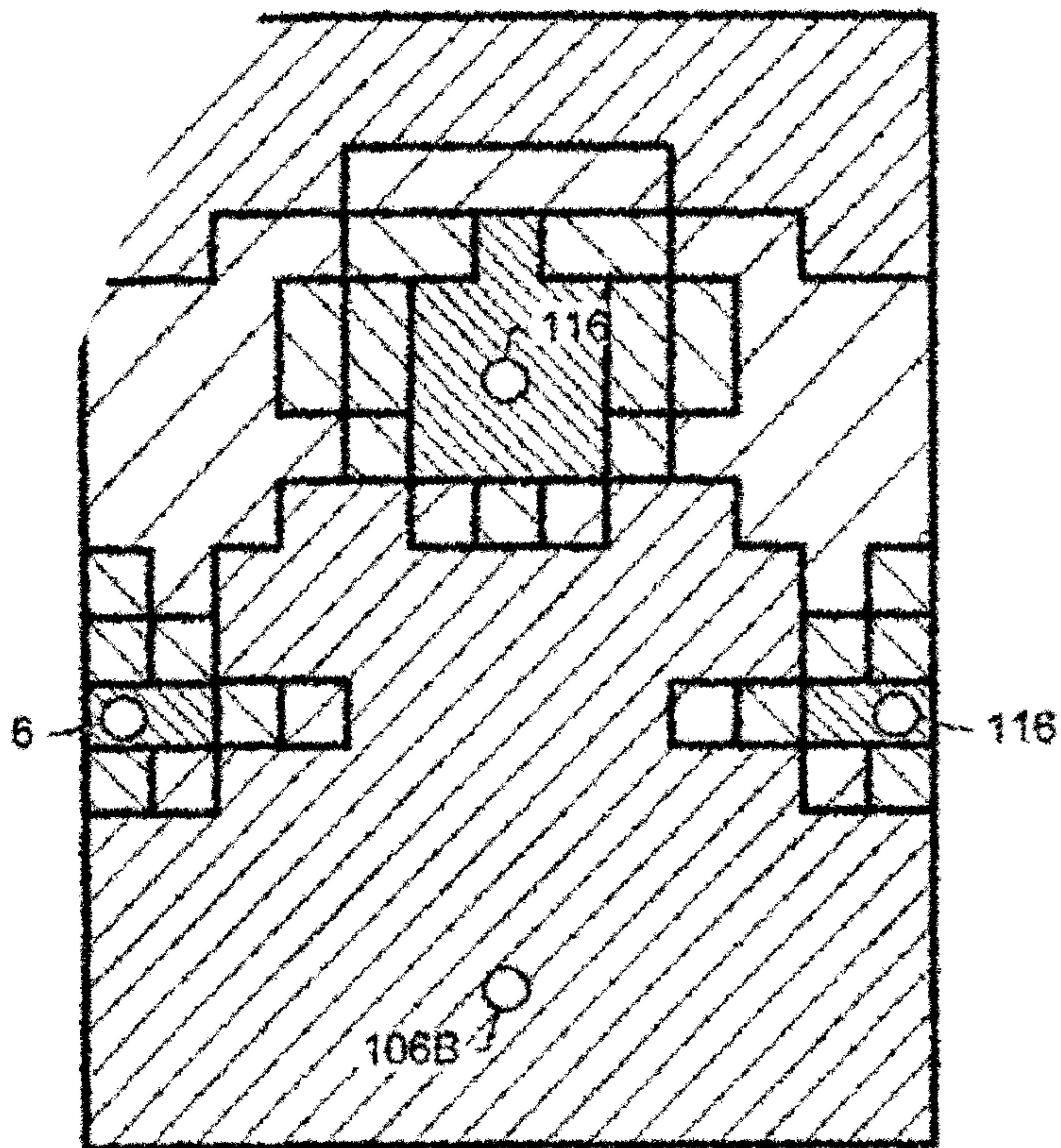
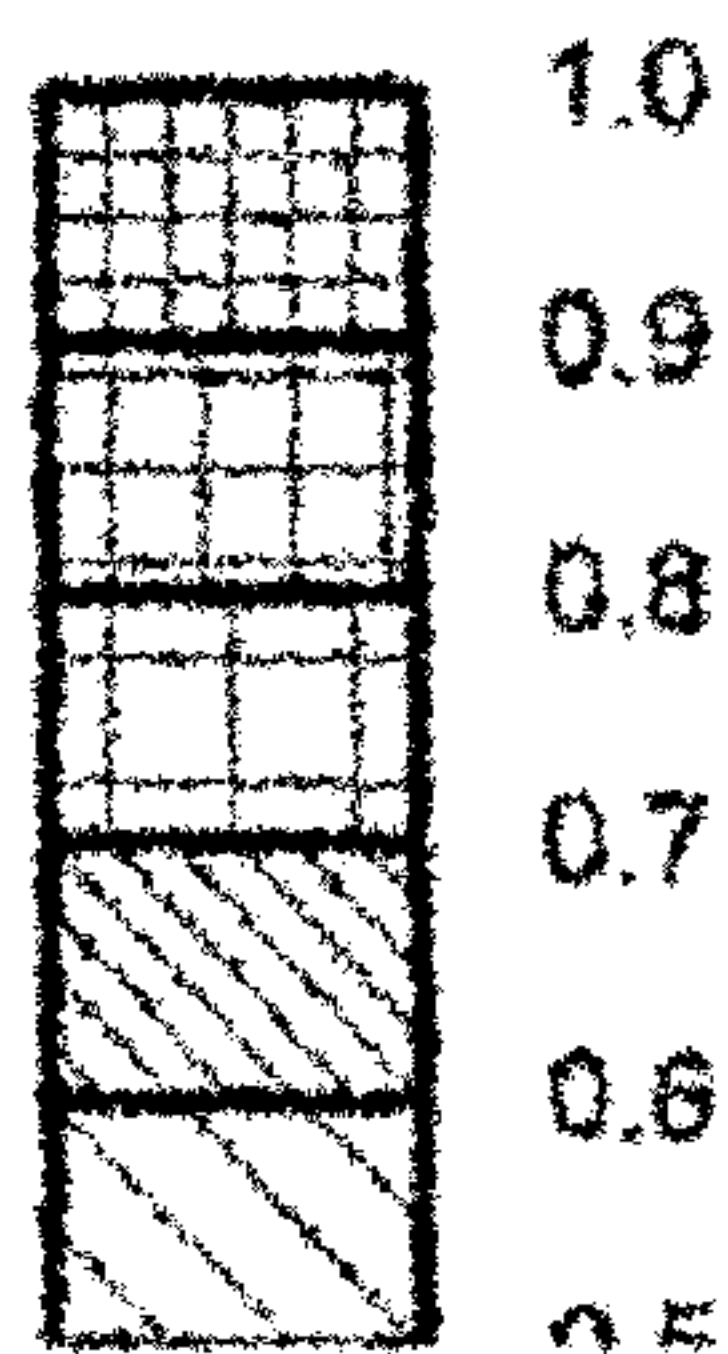
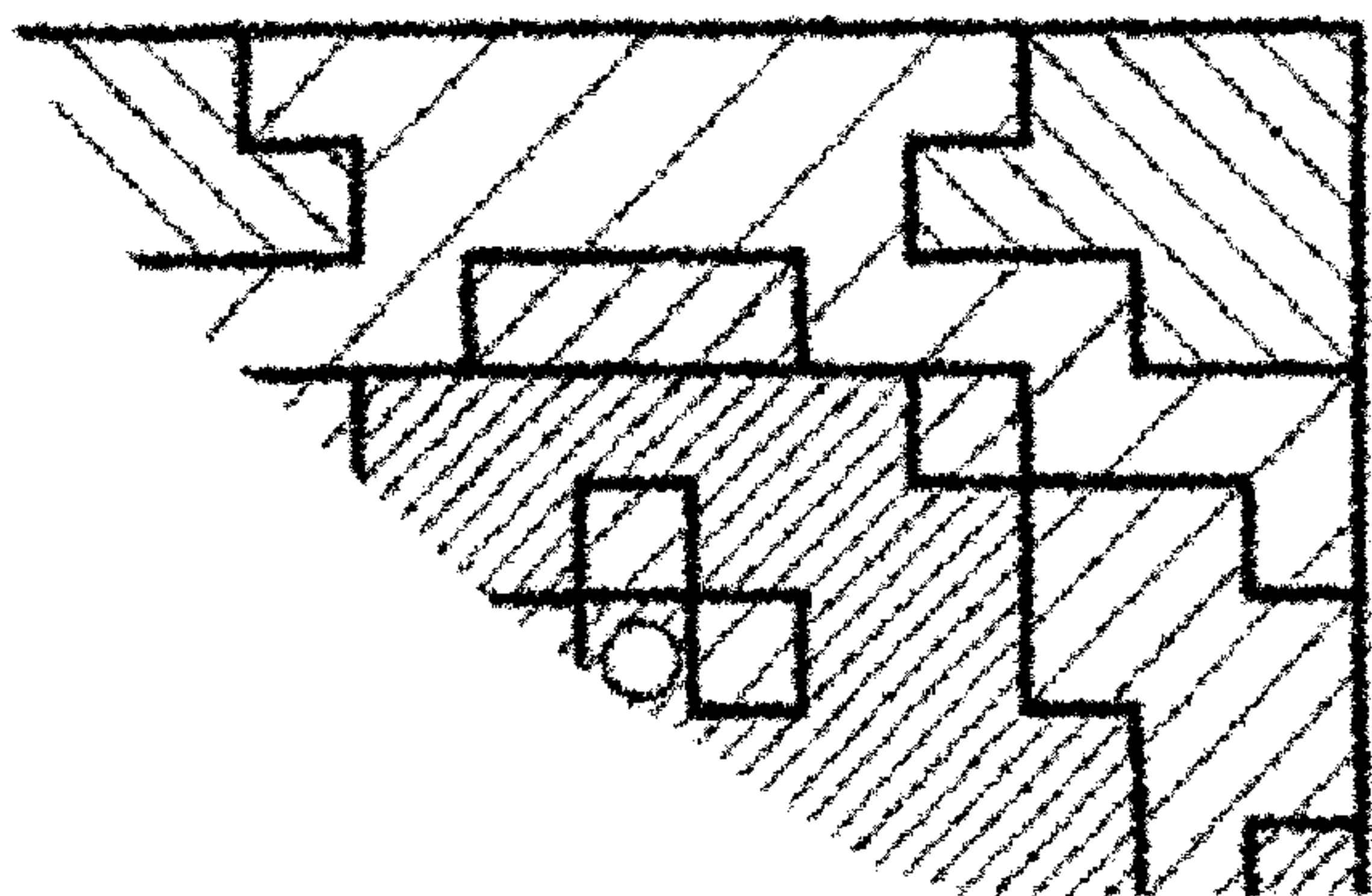

FIG. 12



11/21

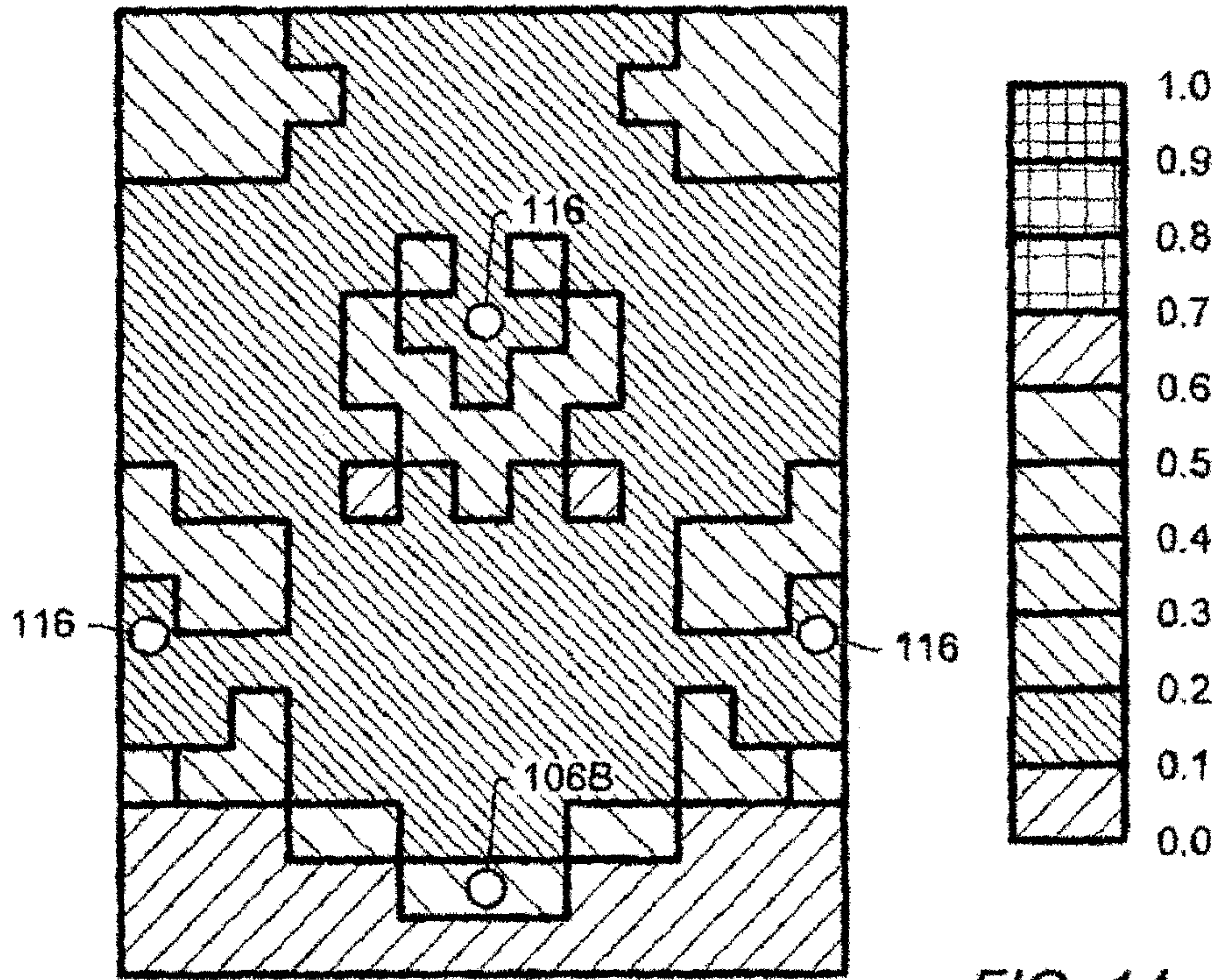
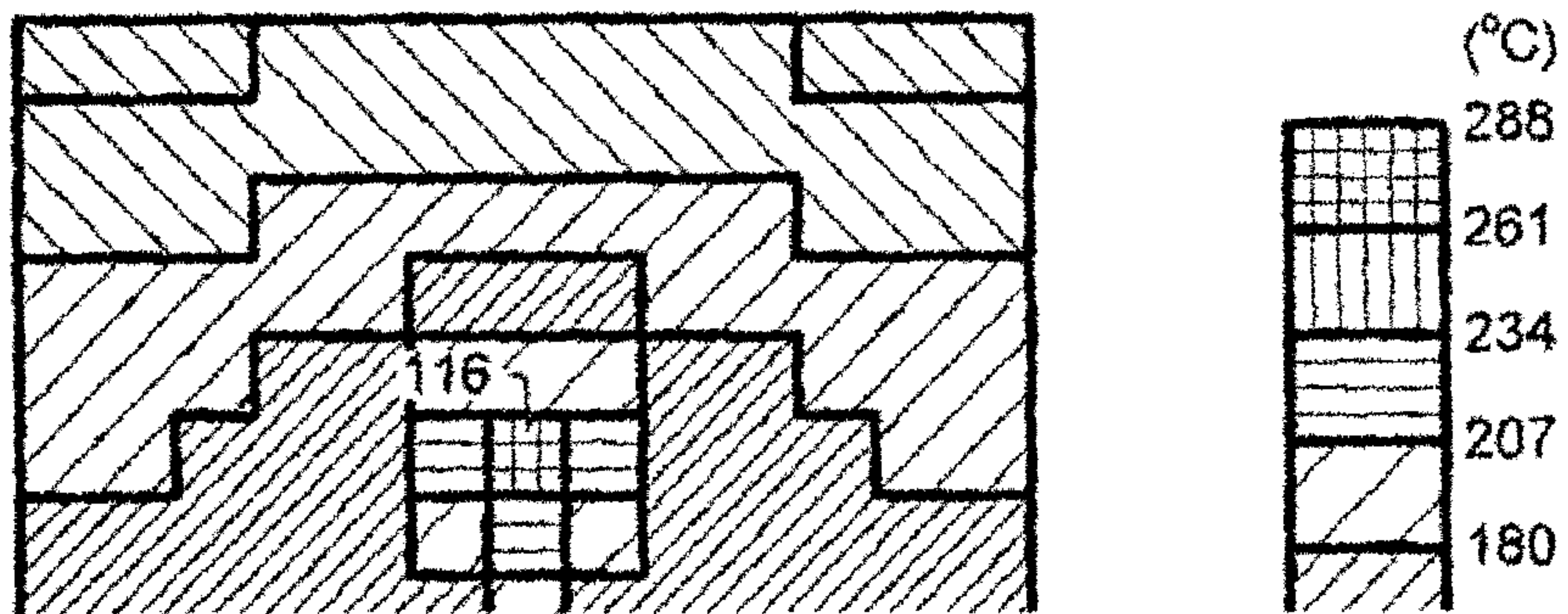

FIG. 14



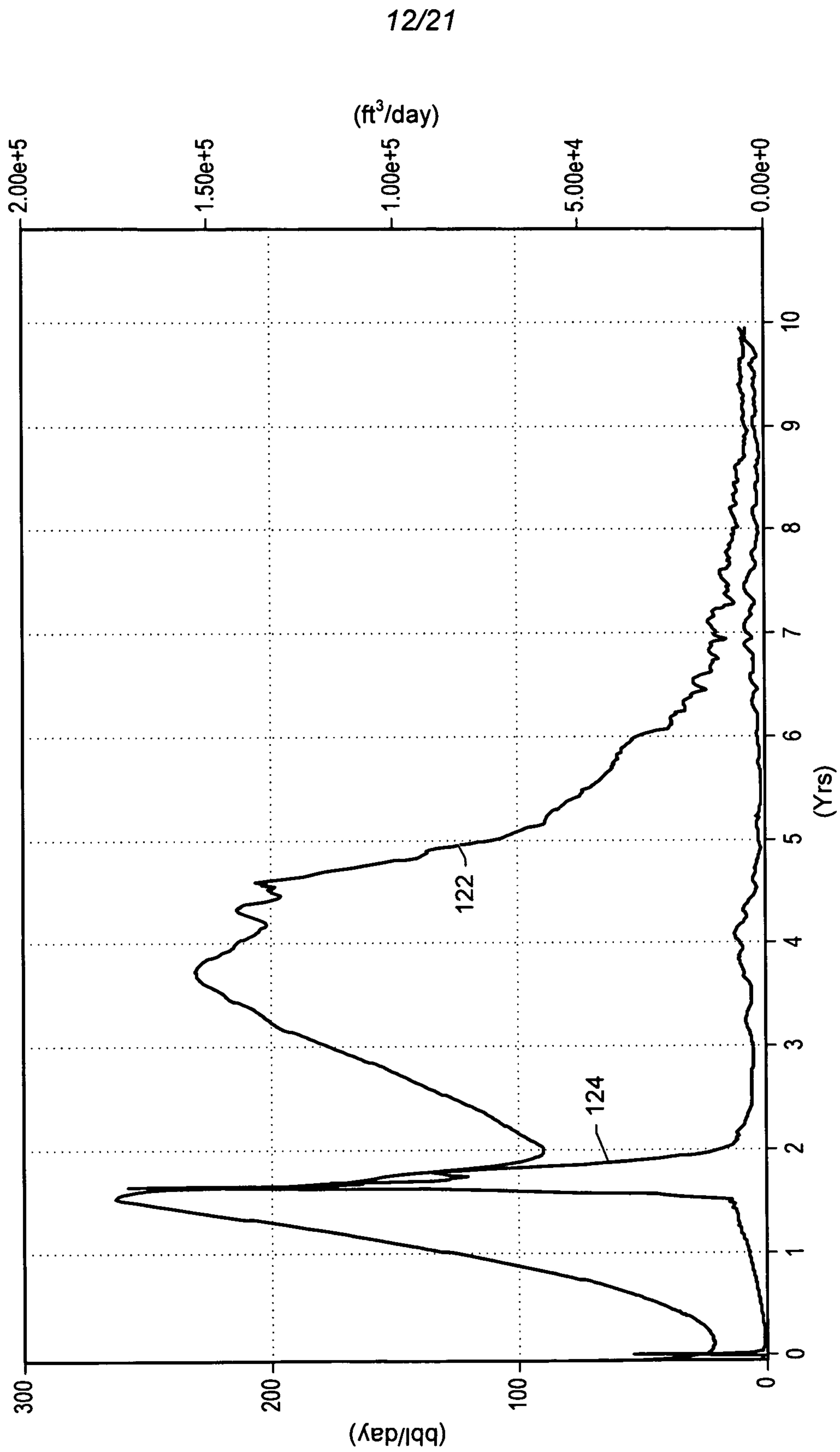

FIG. 16

13/21

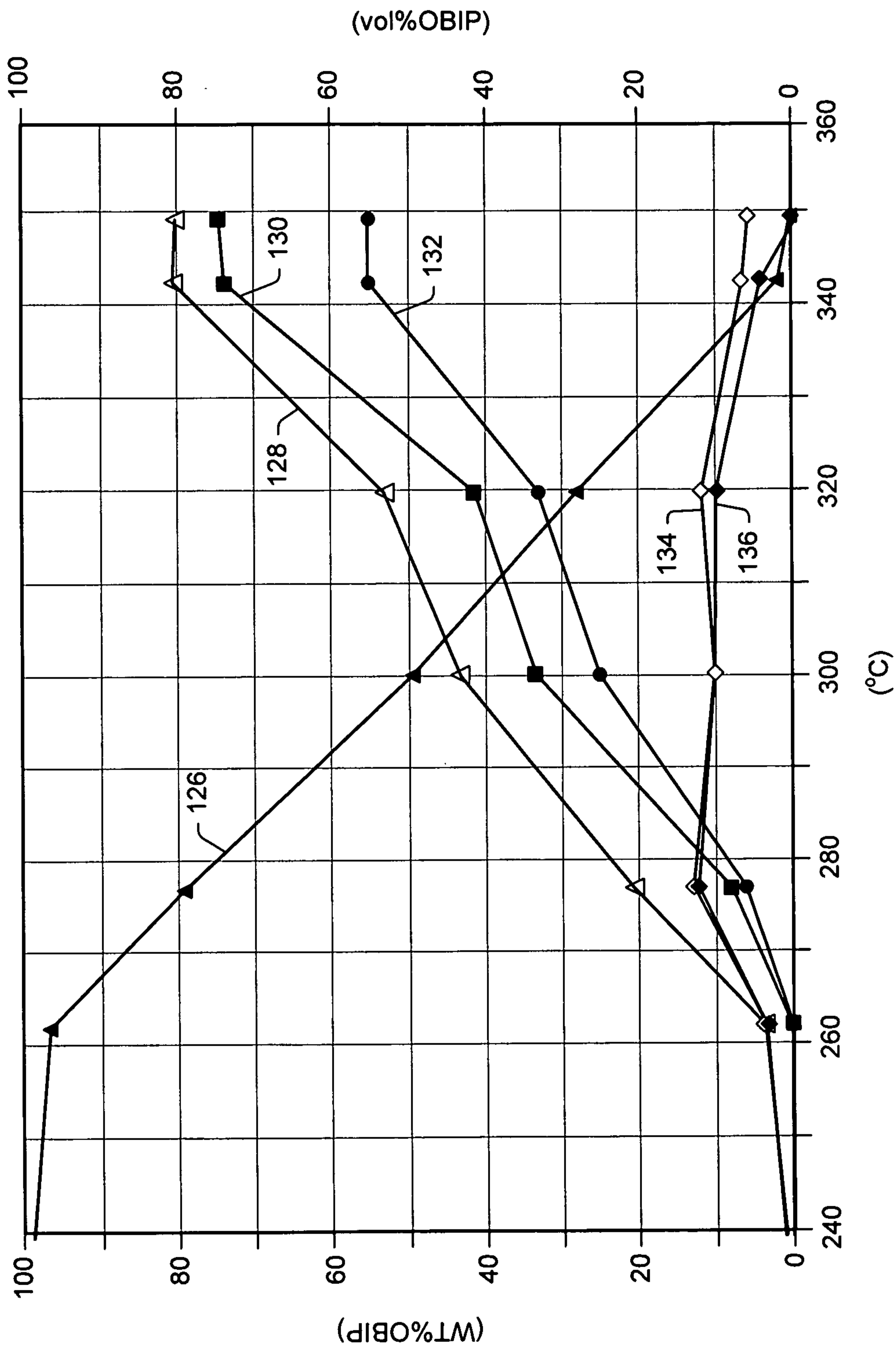

FIG. 17

14/21

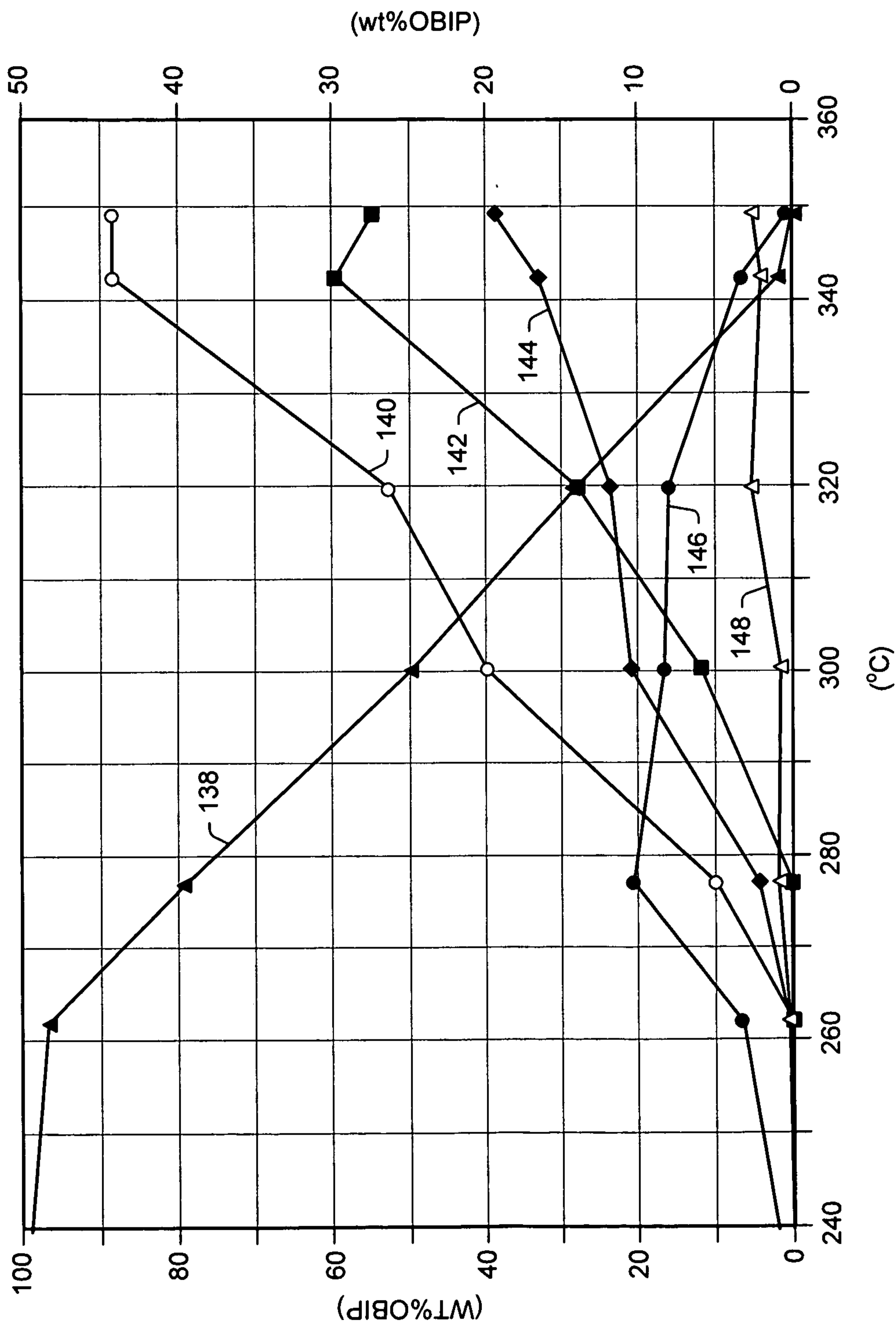

FIG. 18

15/21

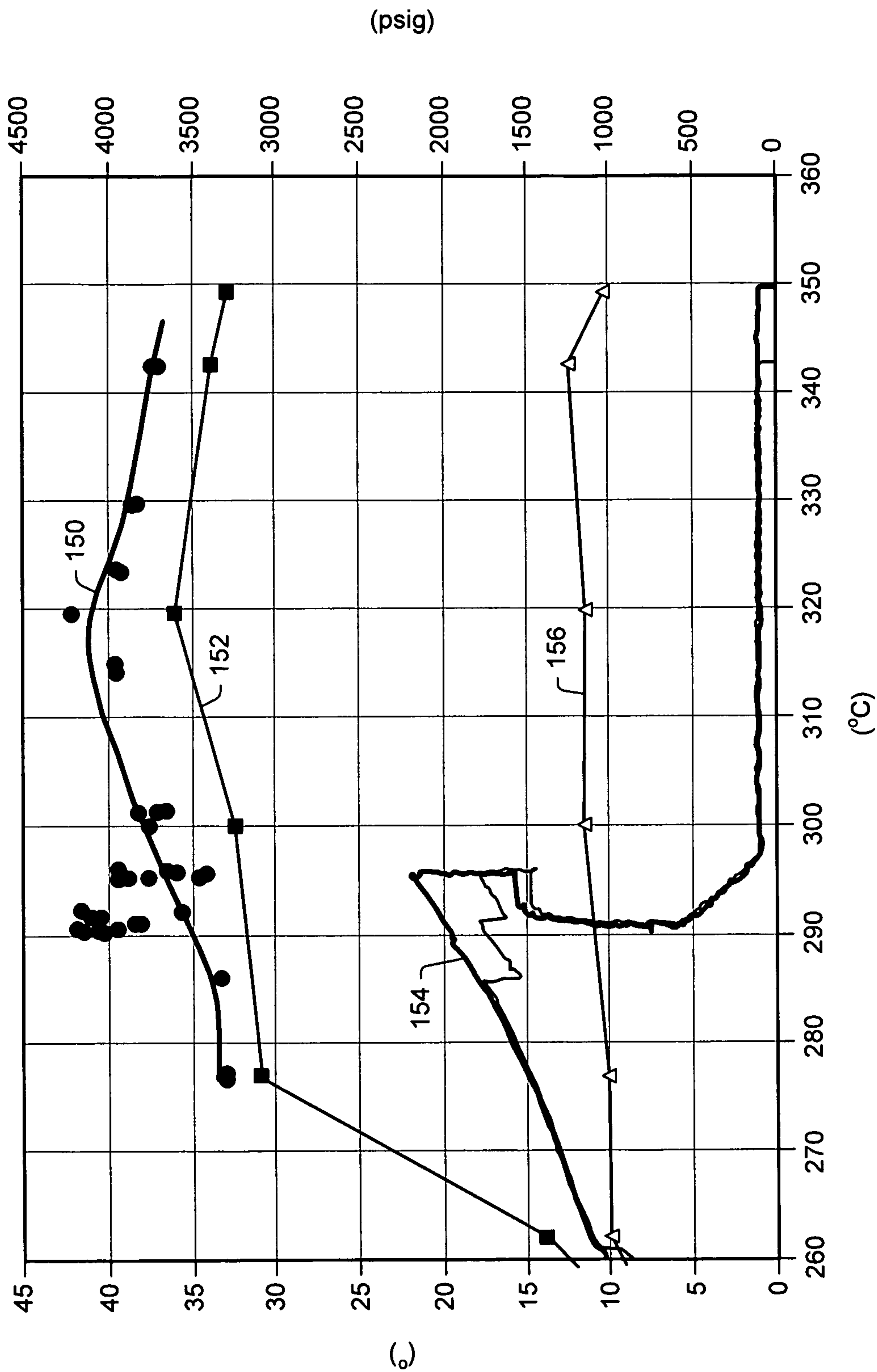

FIG. 19

FIG. 20B

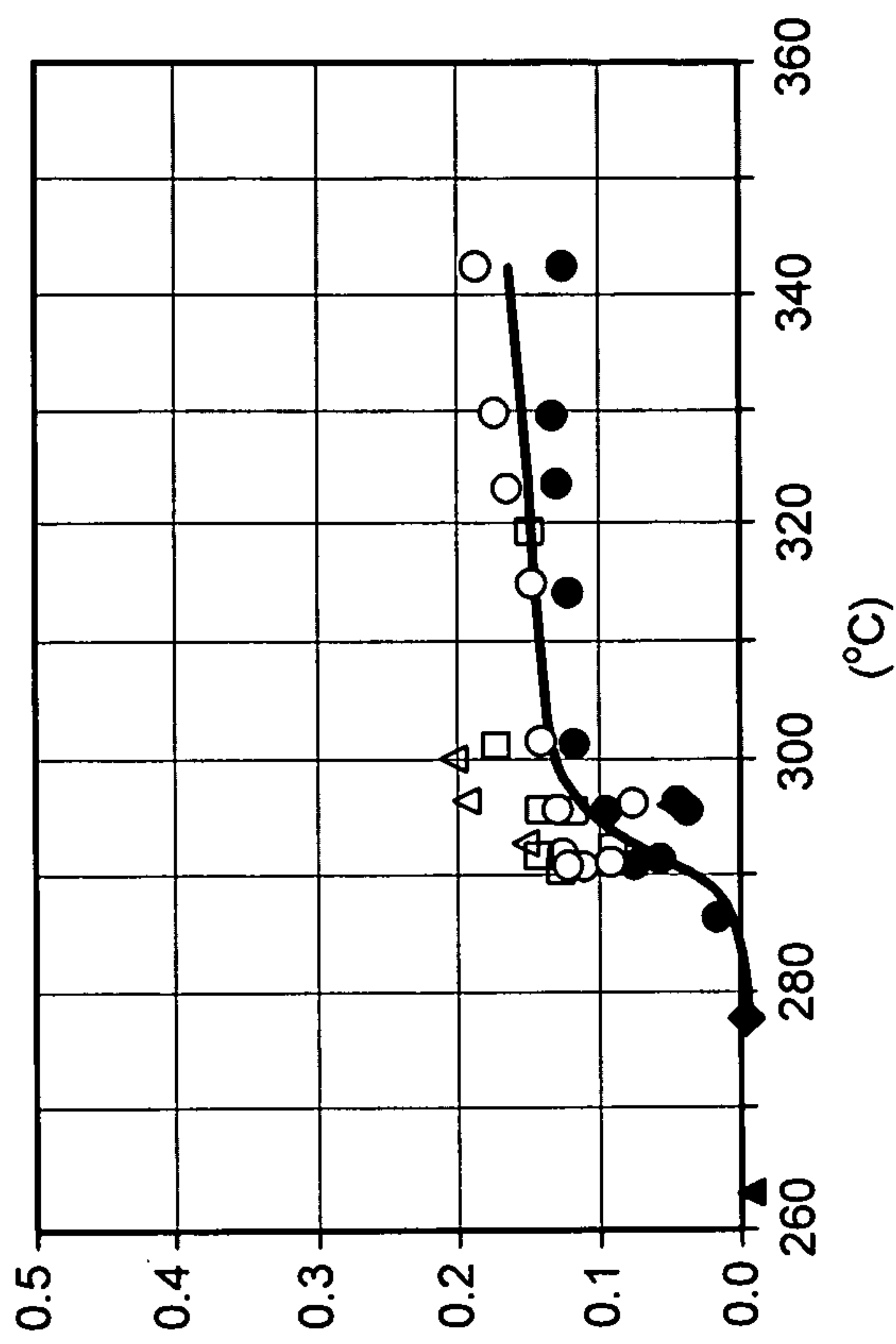
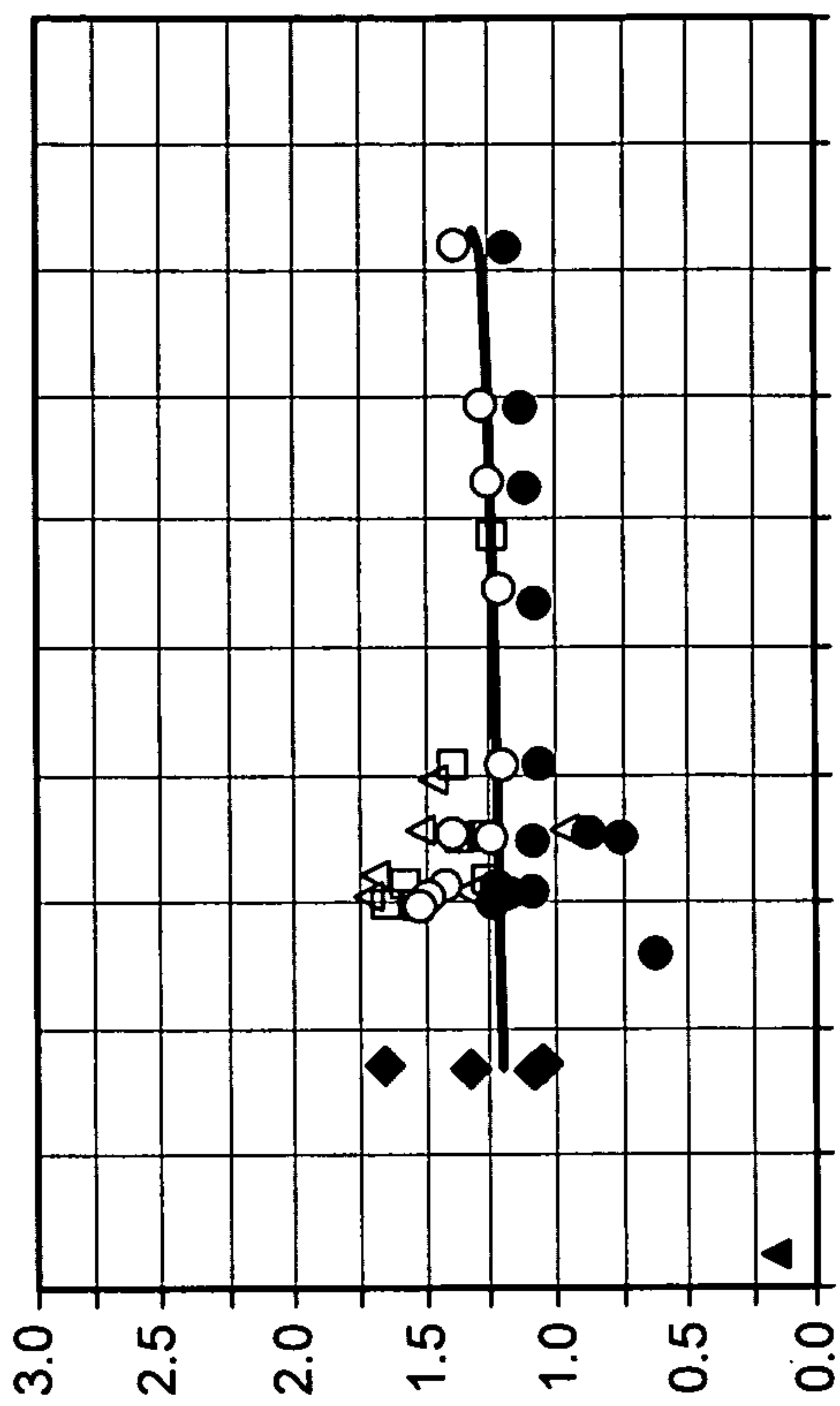

FIG. 20D

FIG. 20A

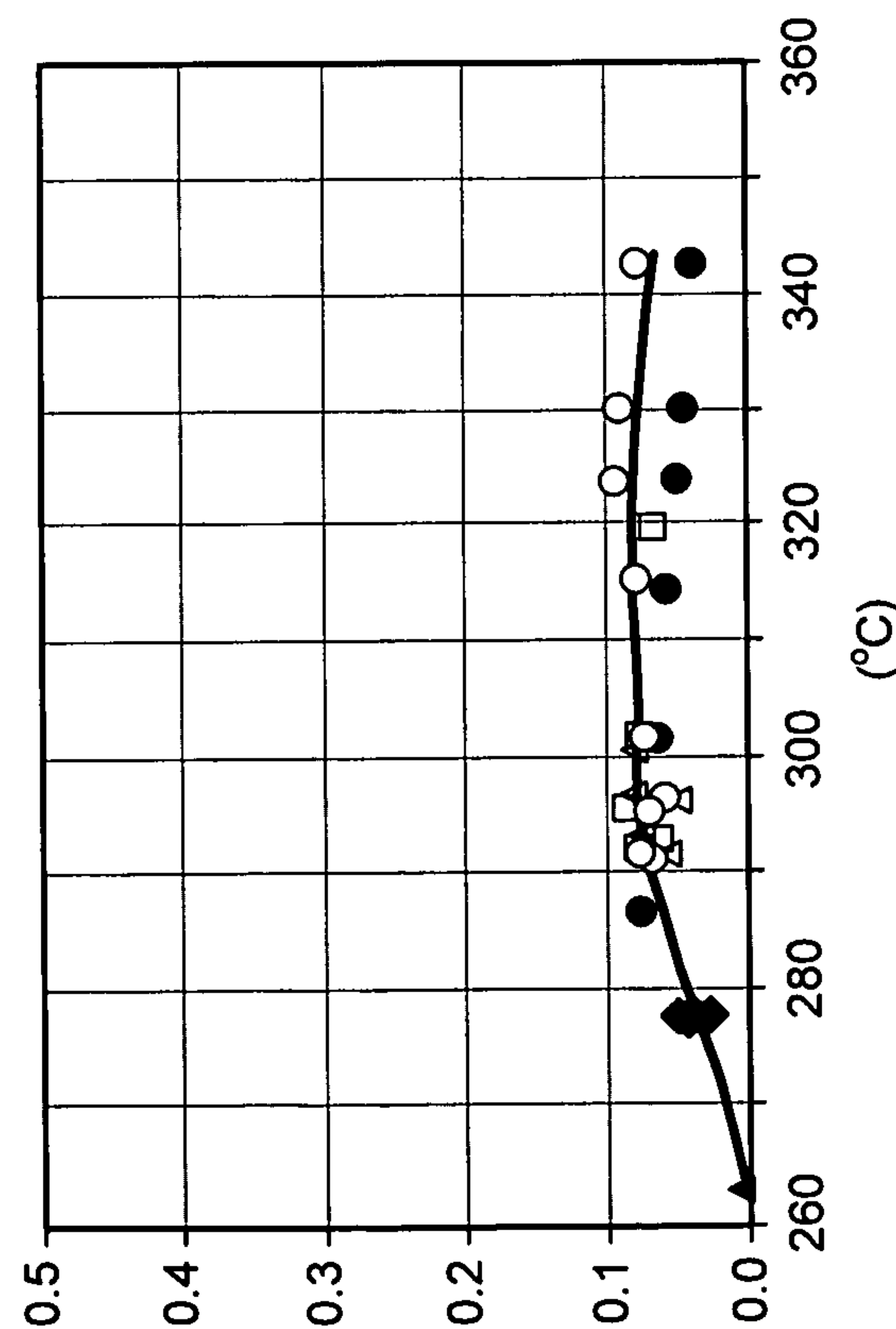
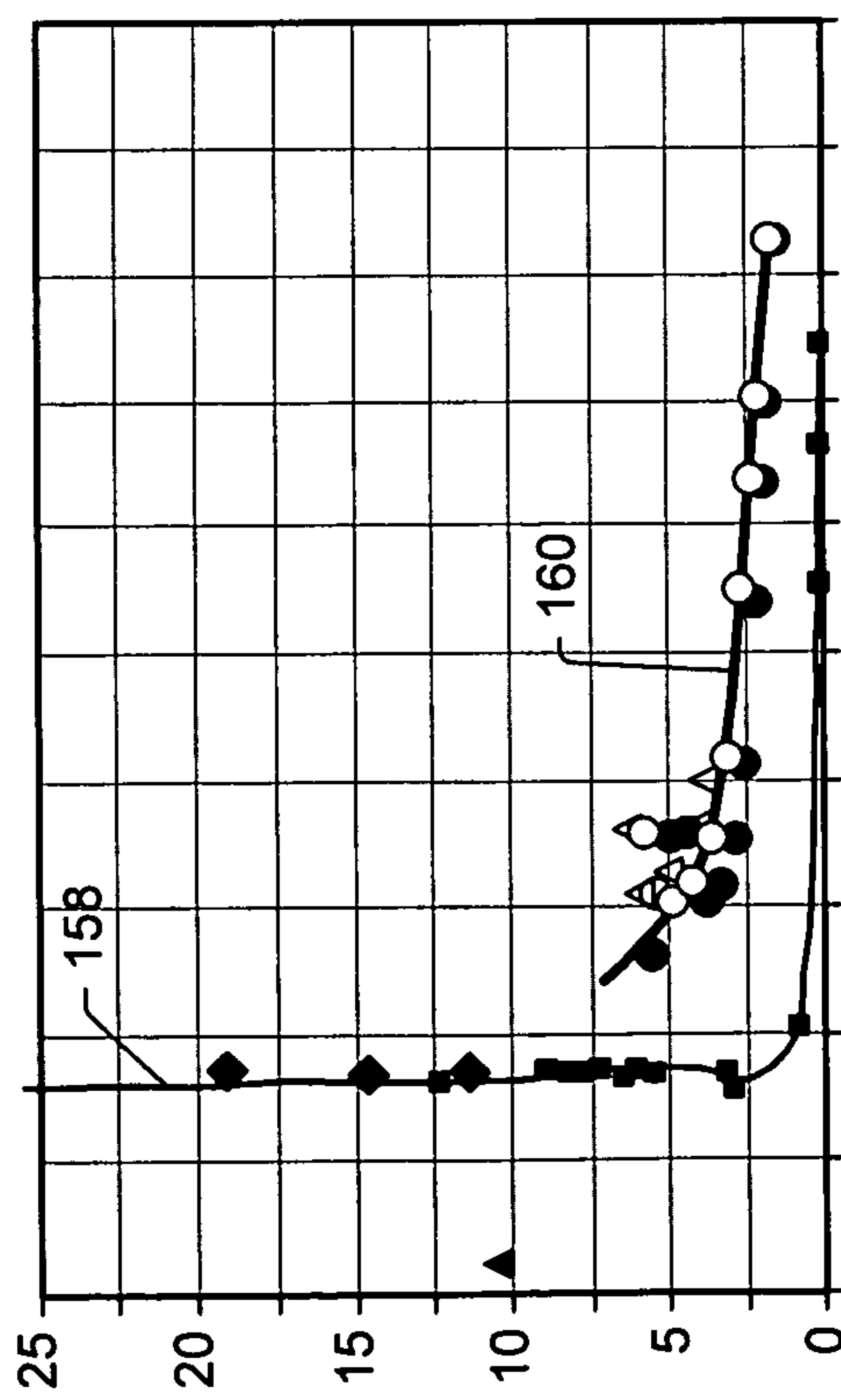

FIG. 20C

17/21

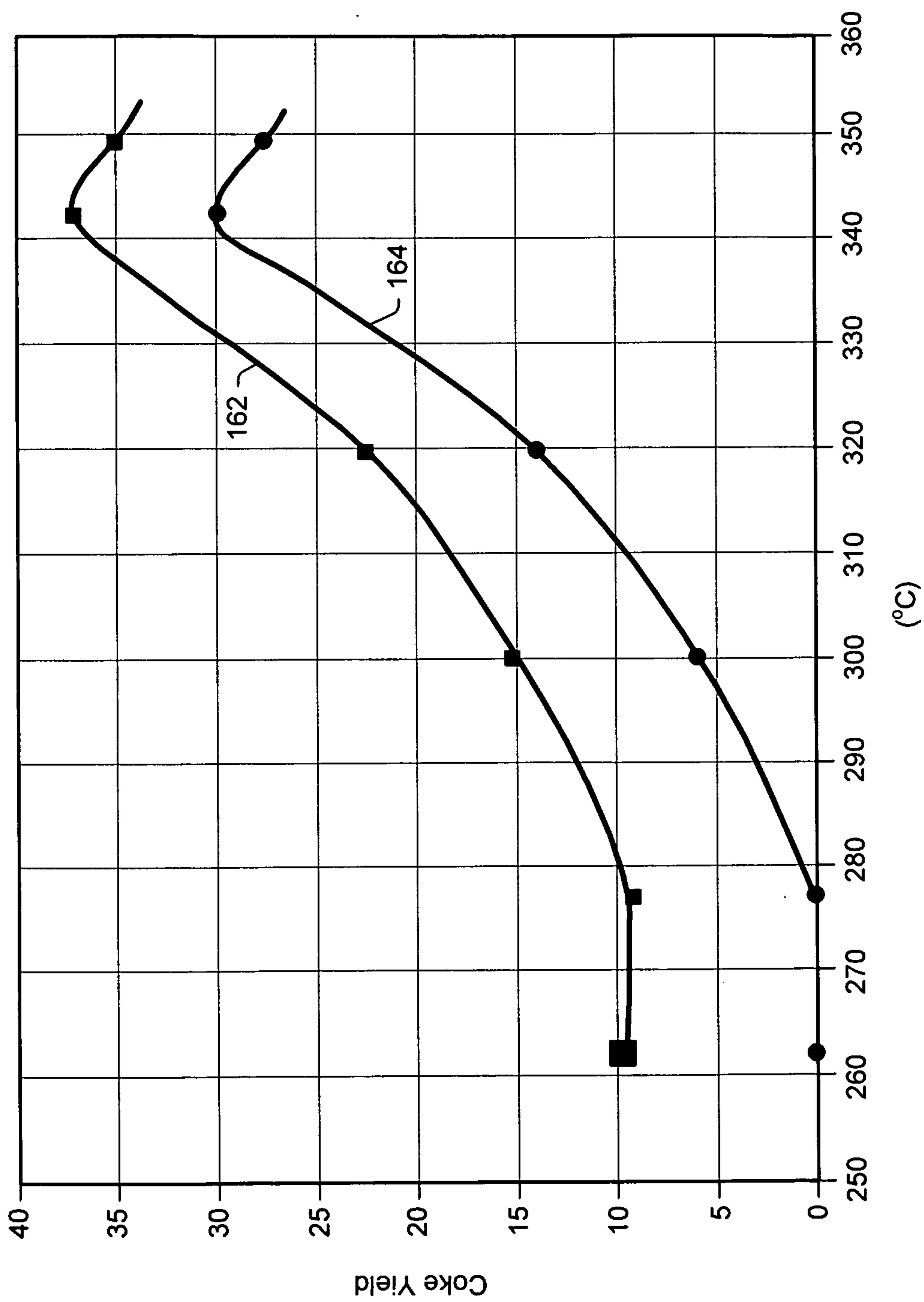

FIG. 21

FIG. 22B

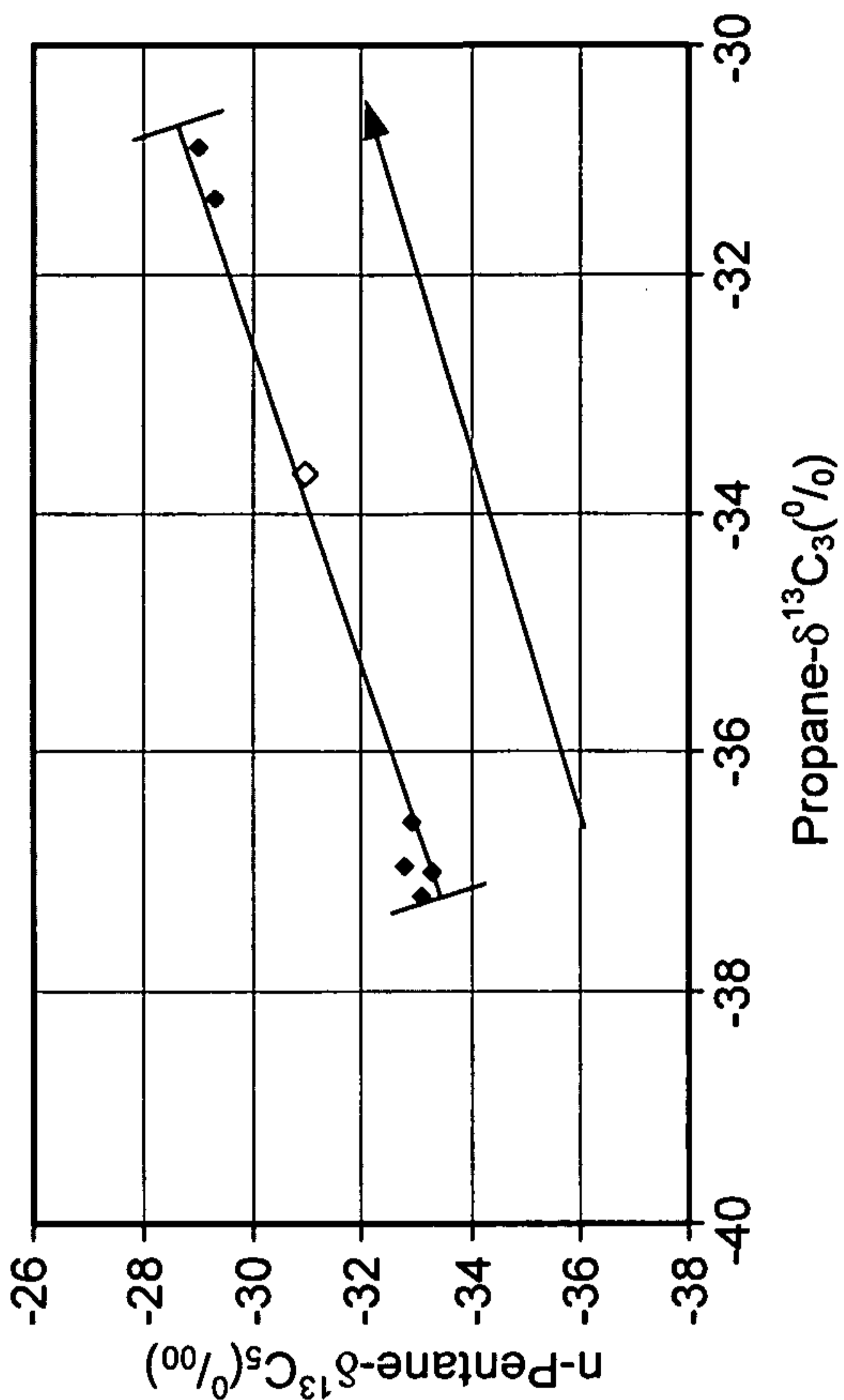

FIG. 22A

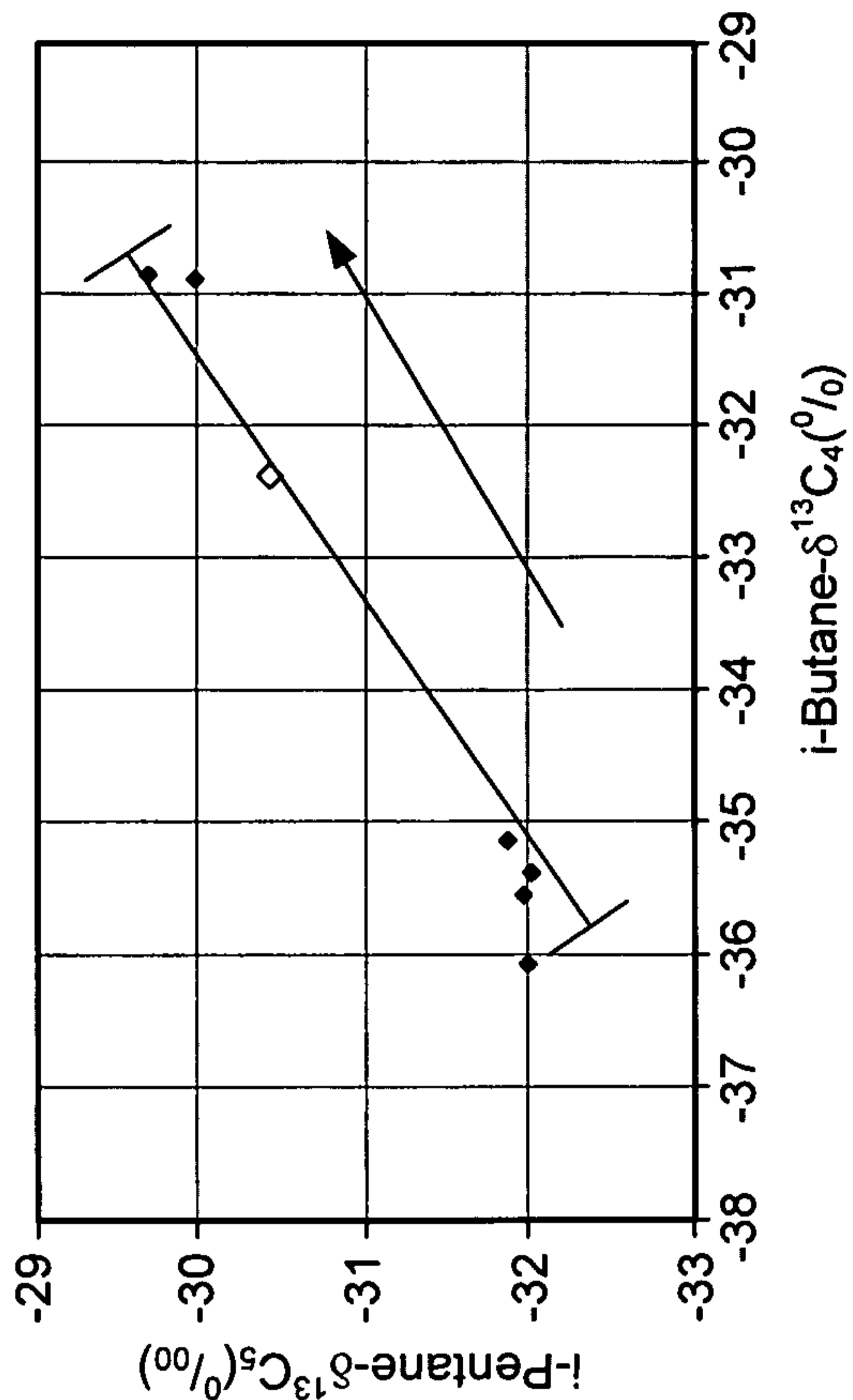
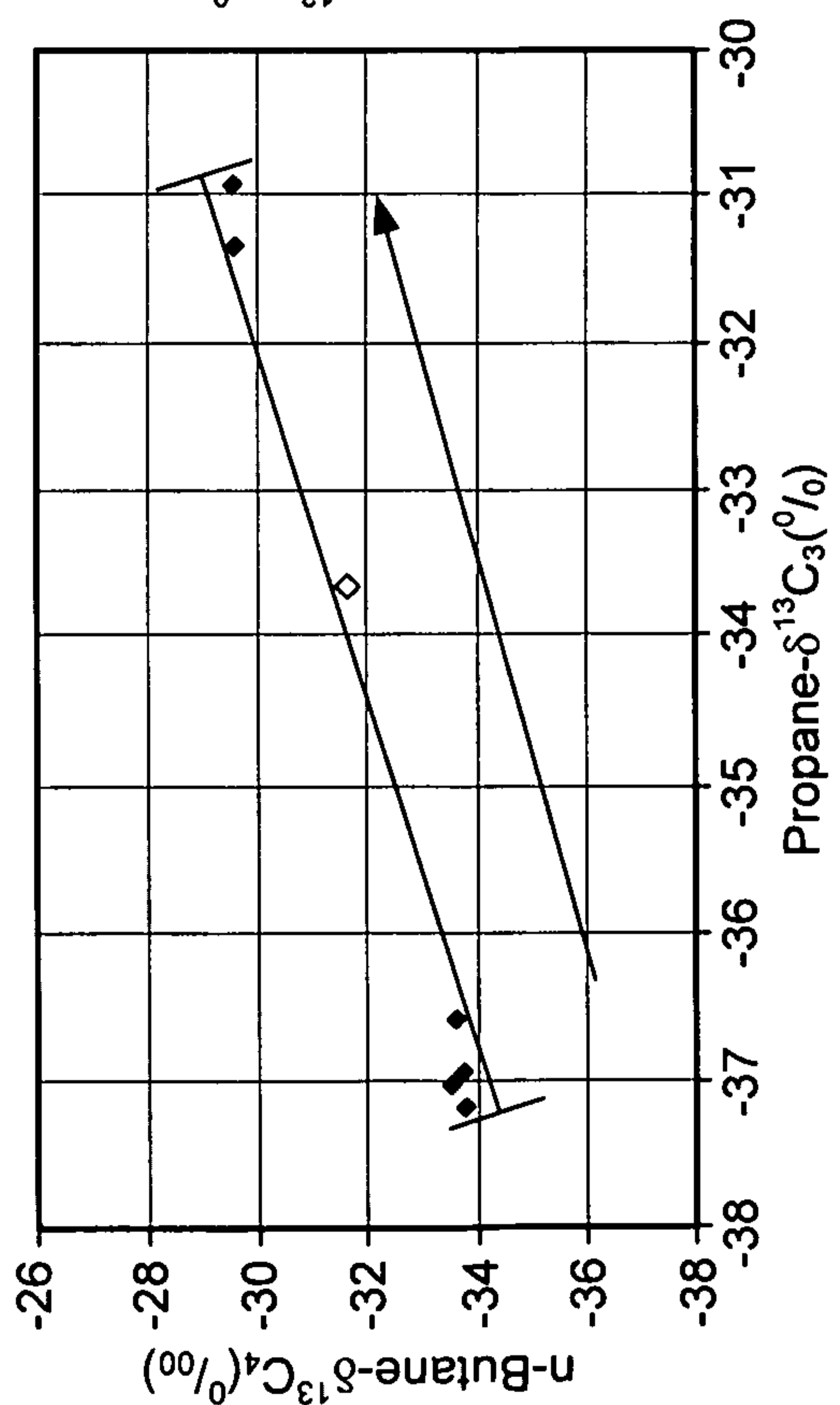

FIG. 22D

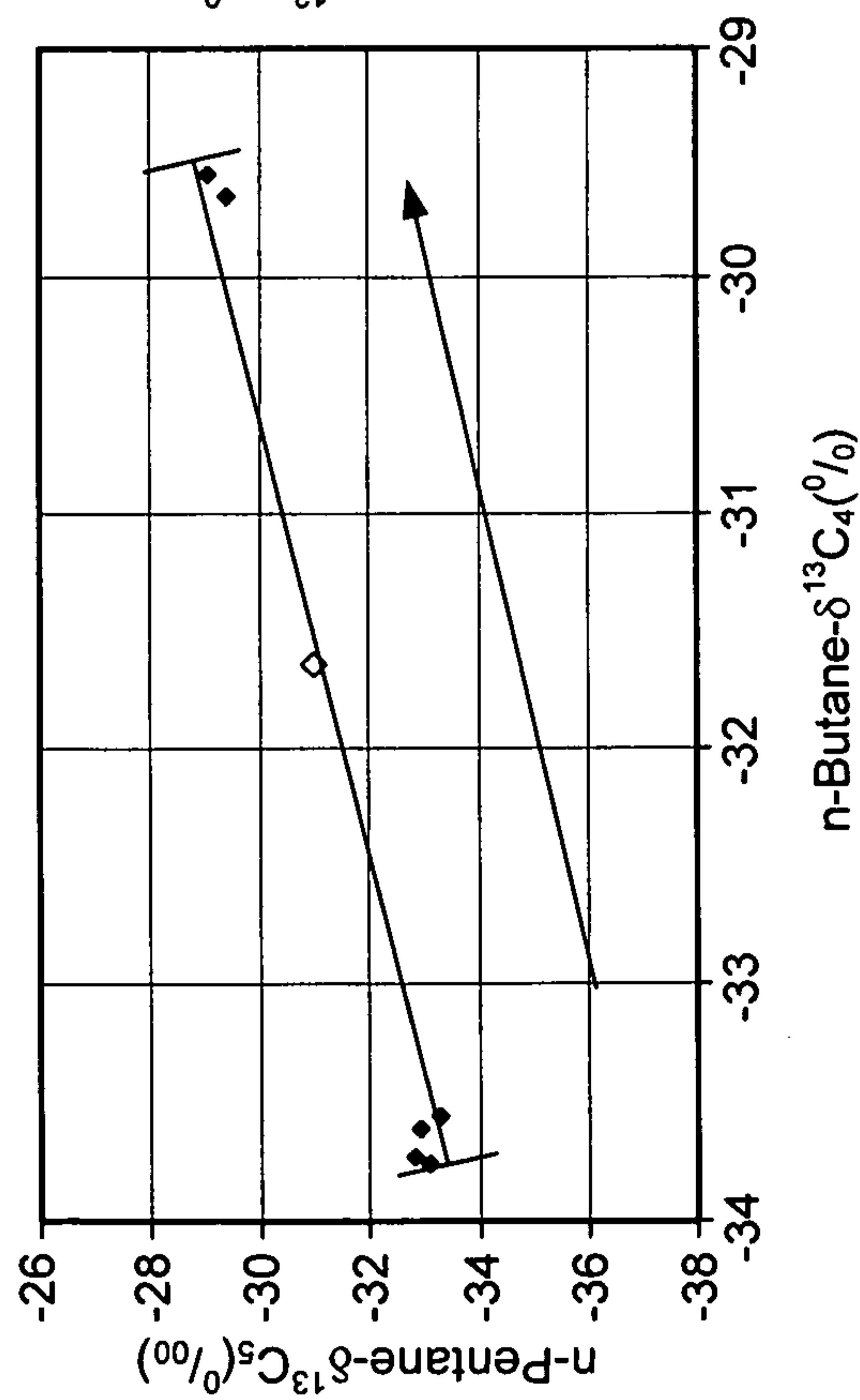

FIG. 22C

19/21

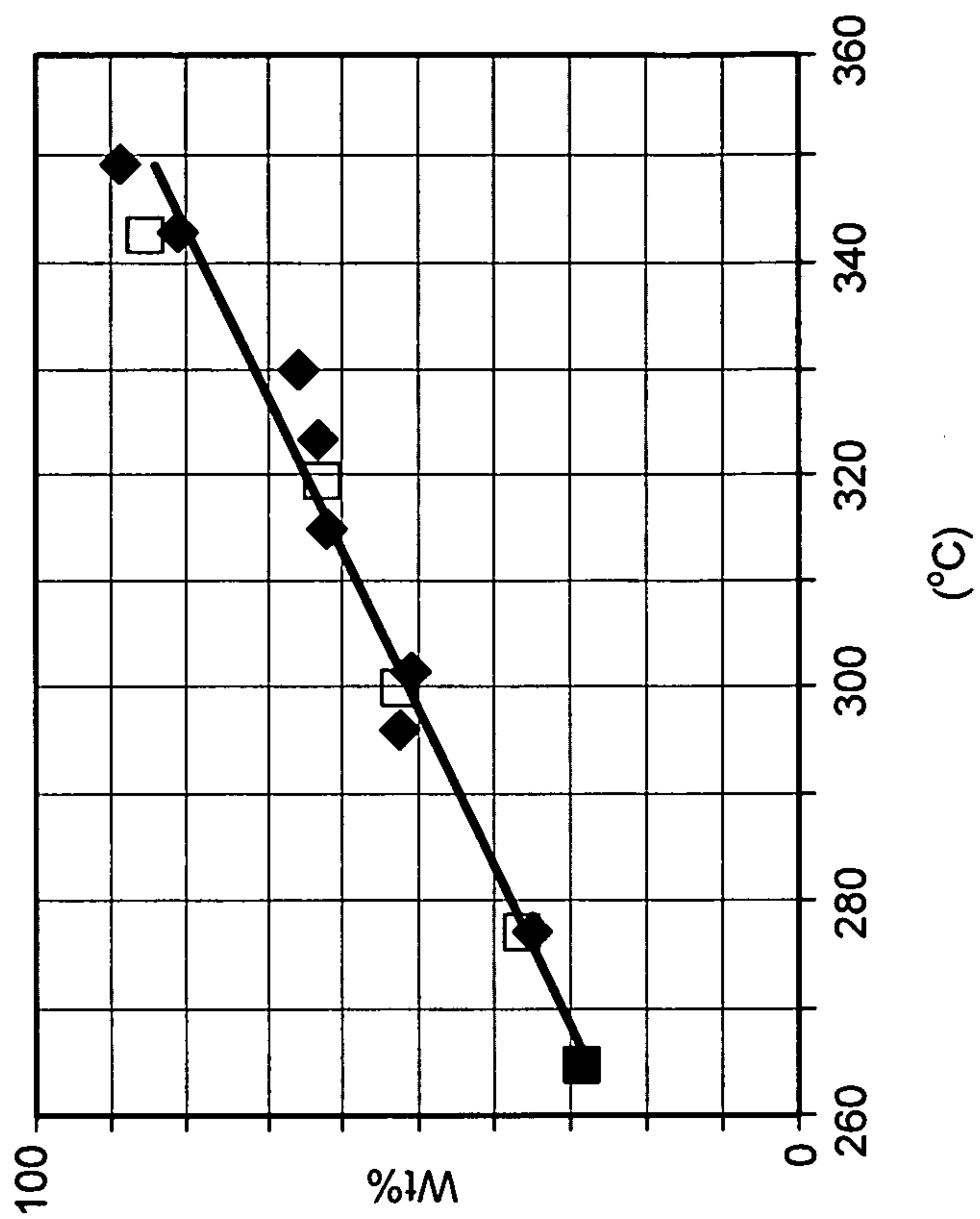

FIG. 24

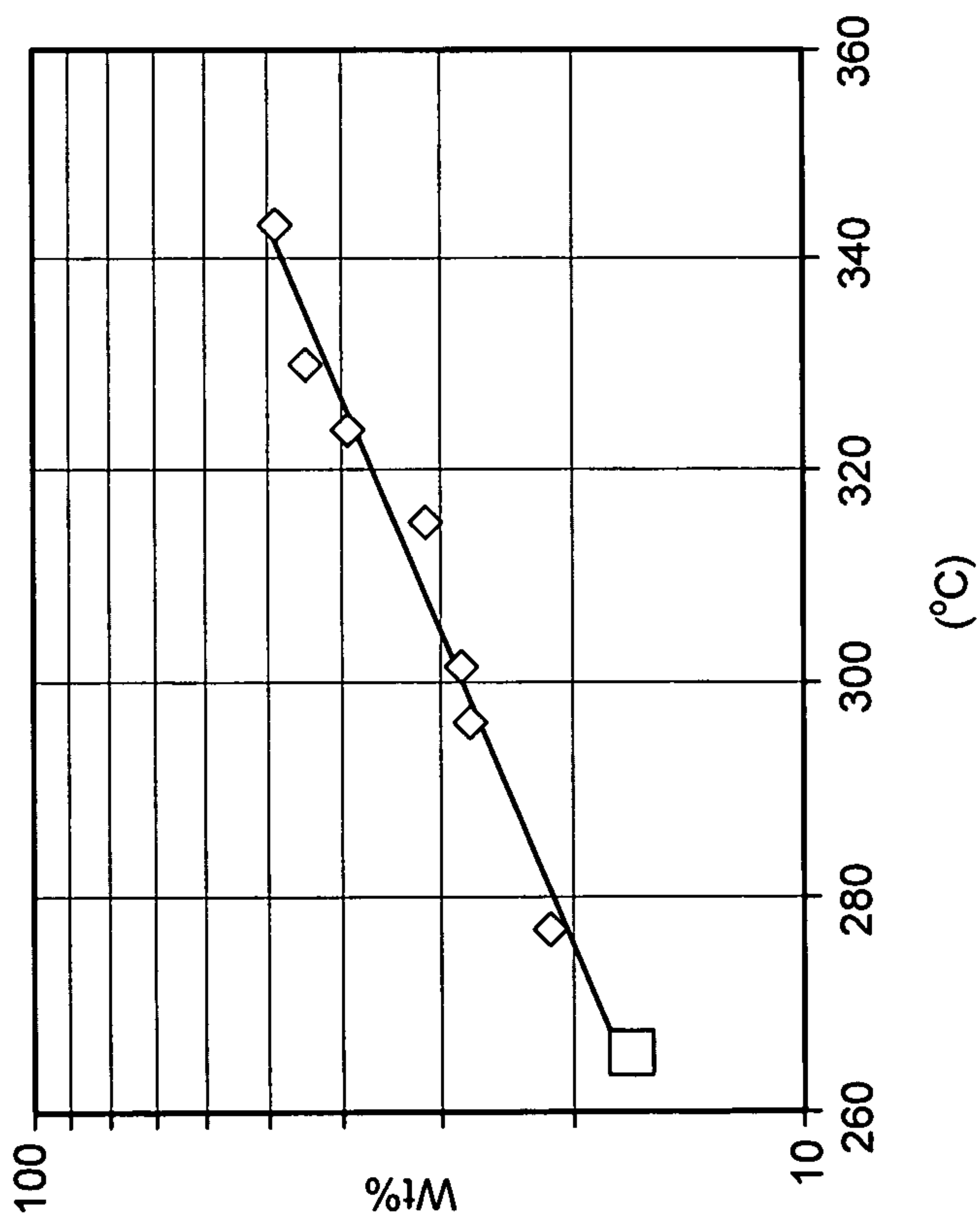

FIG. 23

20/21

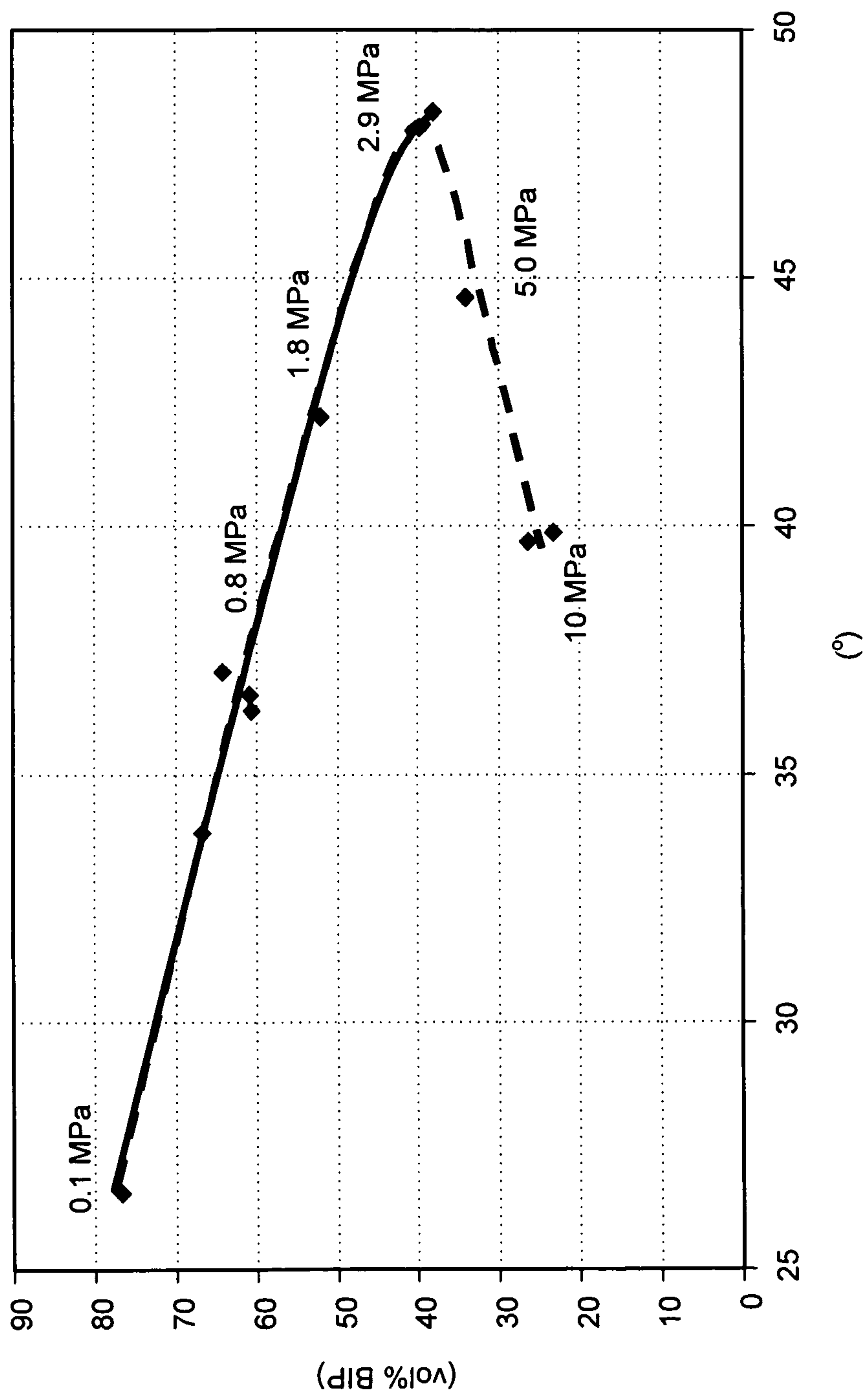

FIG. 25

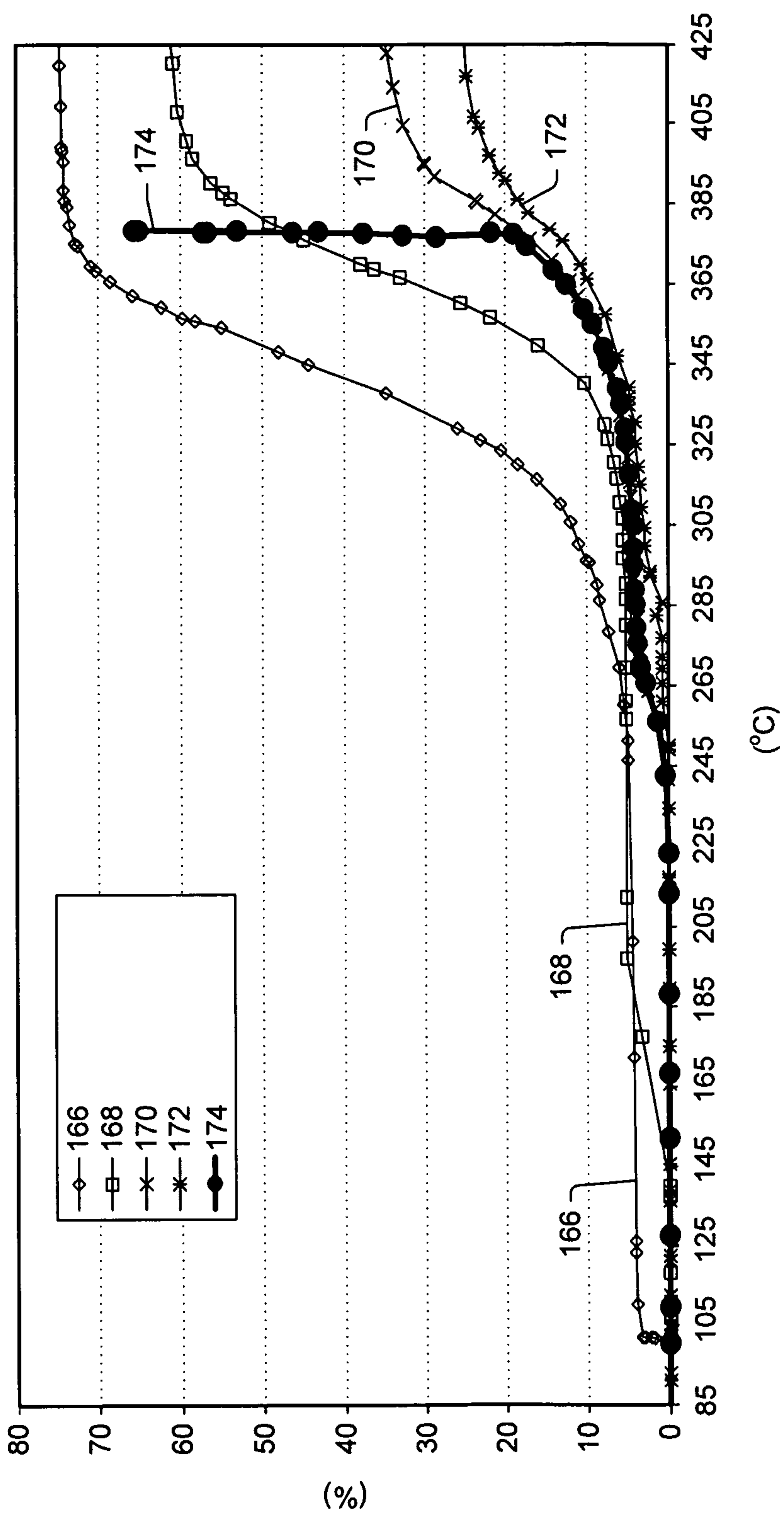

FIG. 26

