



(19) **United States**

(12) **Patent Application Publication**

Jung et al.

(10) **Pub. No.: US 2007/0146712 A1**

(43) **Pub. Date: Jun. 28, 2007**

(54) **APPARATUS AND METHOD FOR MEASURING OPTICAL CHARACTERISTICS OF AN OBJECT**

Publication Classification

(51) **Int. Cl. G01J 3/51** (2006.01)
(52) **U.S. Cl. 356/419; 356/73**

(76) Inventors: **Wayne D. Jung**, Morton Grove, IL (US); **Russell W. Jung**, Morton Grove, IL (US); **Alan R. Loudermilk**, Chicago, IL (US)

(57) **ABSTRACT**

Optical characteristic measuring systems and methods such as for determining the color or other optical characteristics of an object are disclosed. Perimeter receiver fiber optics are spaced apart from a source fiber optic and receive light from the surface of the object being measured. Light from the perimeter fiber optics pass to a variety of filters. The system utilizes the perimeter receiver fiber optics to determine information regarding the height and angle of the probe with respect to the object being measured. Under processor control, the optical characteristics measurement may be made at a predetermined height and angle. Various color spectral photometer arrangements are disclosed. Translucency, fluorescence, gloss and/or surface texture data also may be obtained. Audio feedback may be provided to guide operator use of the system. The probe may have a removable or shielded tip for contamination prevention. A method of producing prostheses based on measured data also is disclosed. Measured data also may be stored and/or organized as part of a data base.

Correspondence Address:
ALAN R. LOUDERMILK
LOUDERMILK & ASSOCIATES
PO BOX 3607
LOS ALTOS, CA 94024-0607 (US)

(21) Appl. No.: **11/542,606**
(22) Filed: **Oct. 2, 2006**

Related U.S. Application Data

(63) Continuation of application No. 11/118,903, filed on Apr. 29, 2005, now Pat. No. 7,119,892, which is a continuation of application No. 10/302,215, filed on Nov. 22, 2002, which is a continuation of application No. 09/462,020, filed on Dec. 29, 1999, now Pat. No. 6,501,542, filed as 371 of international application No. PCT/US98/13764, filed on Jun. 30, 1998.

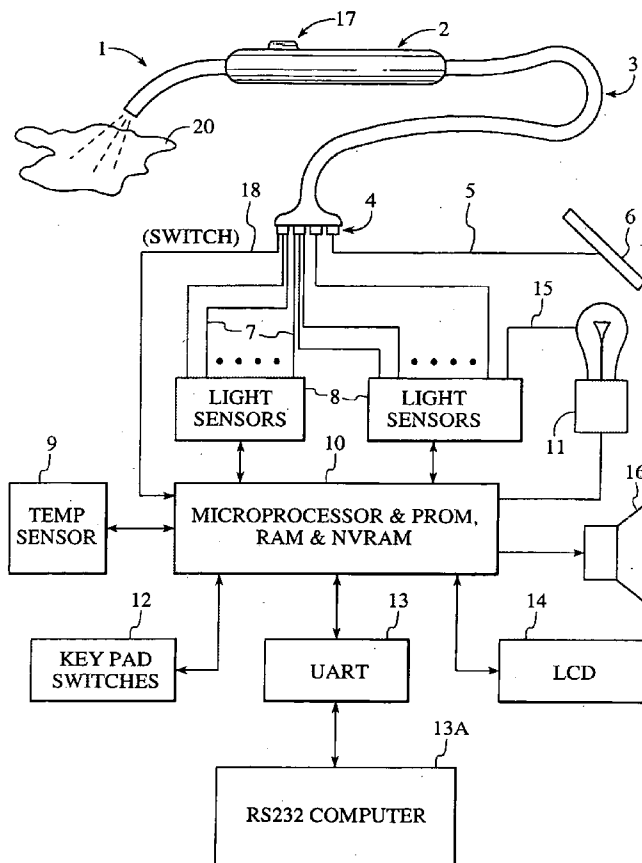

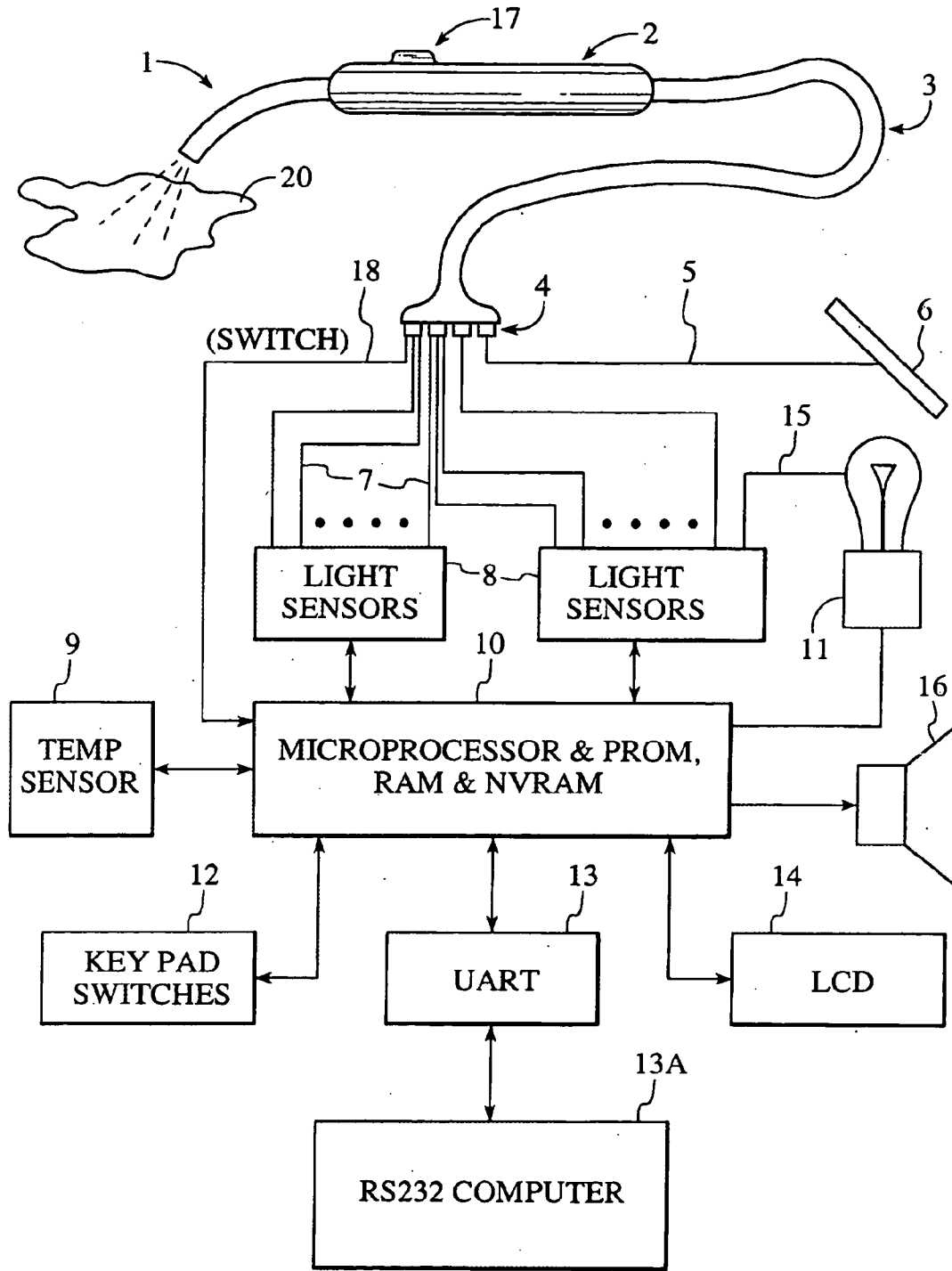

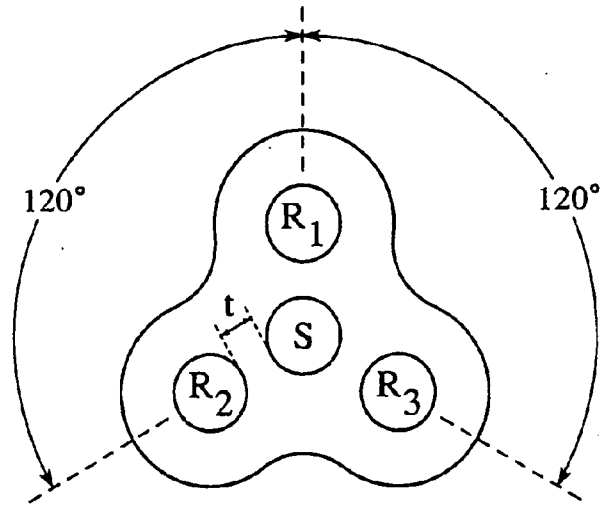

R - LIGHT RECEIVER FIBER OPTICS
S - LIGHT SOURCE FIBER OPTIC

FIG. 2

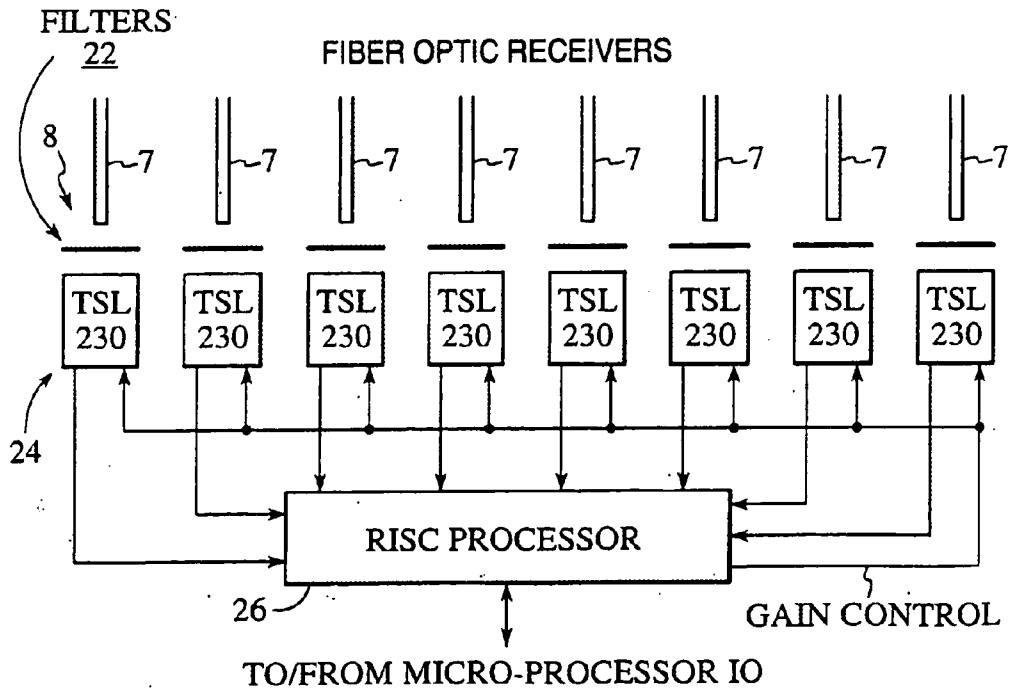

FIG. 3

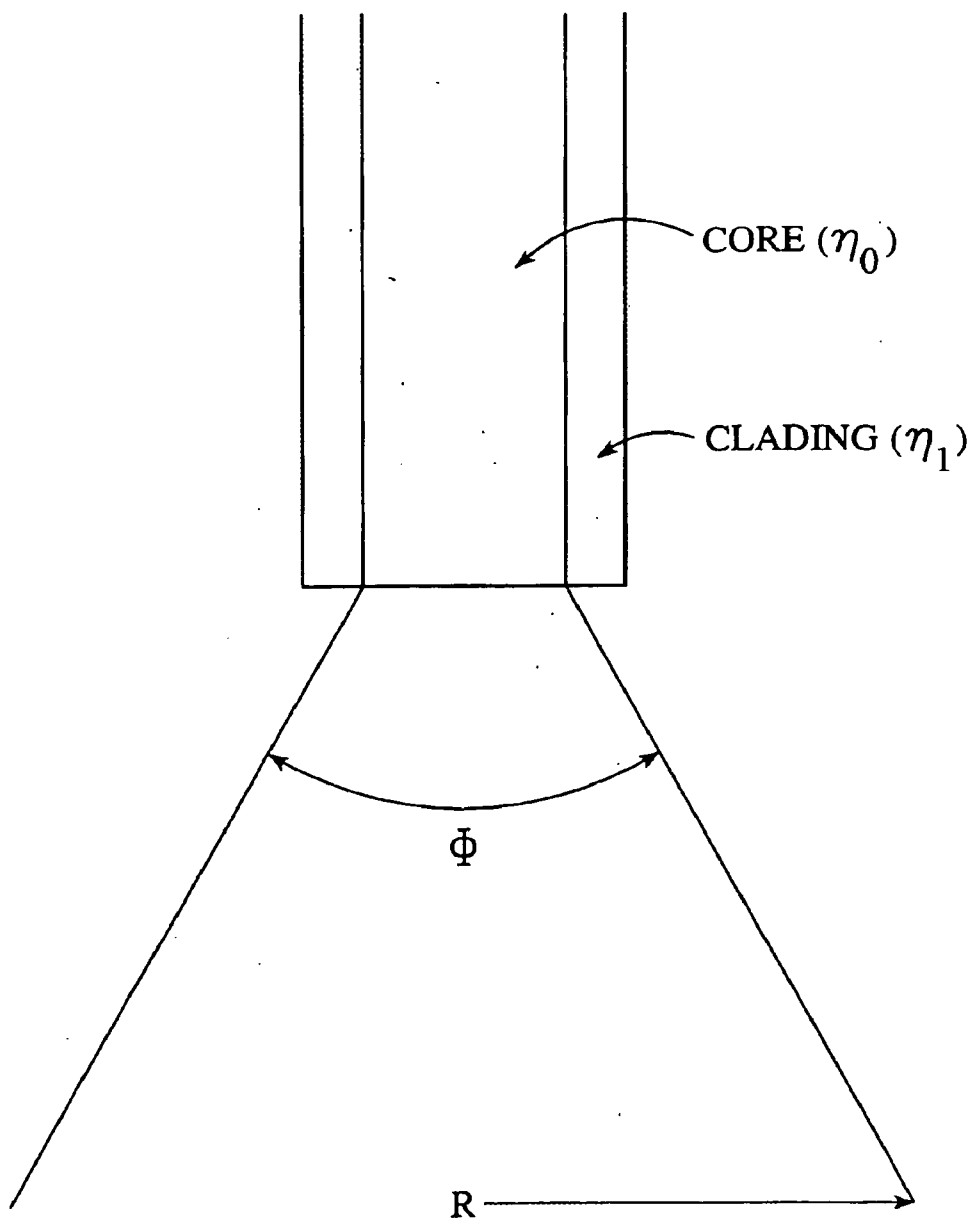

FIG. 4A

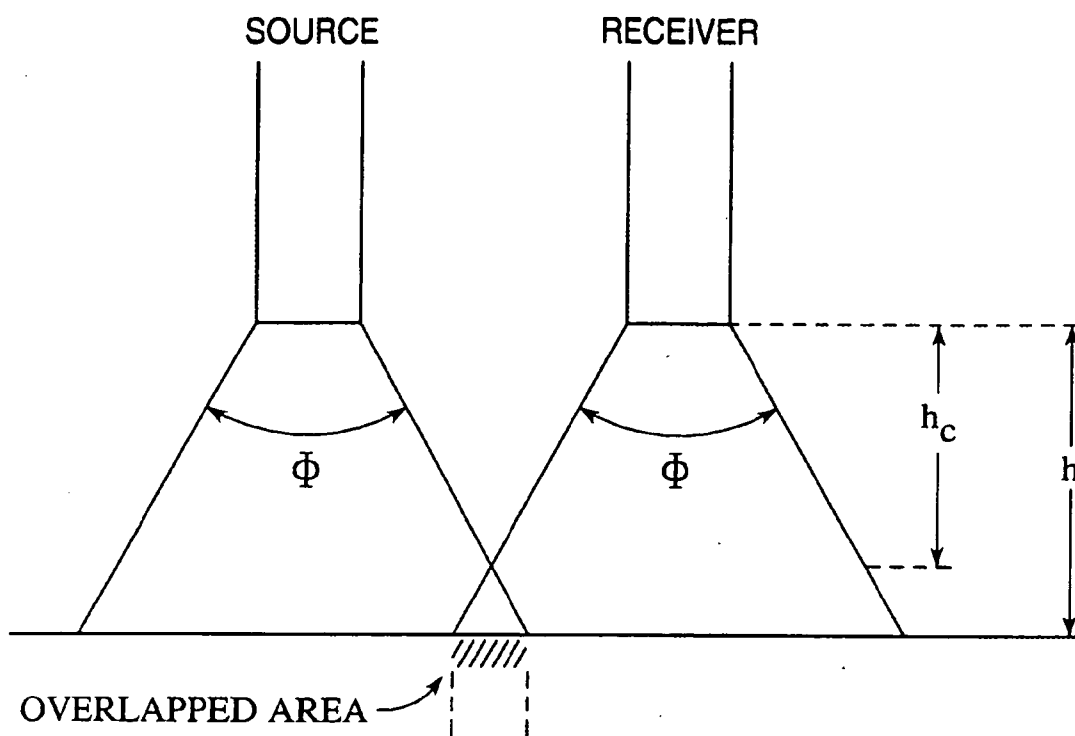

FIG. 4B

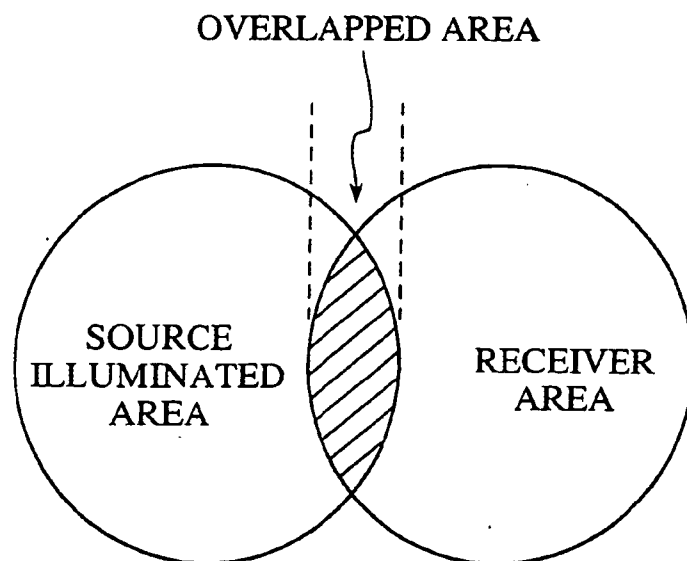

FIG. 4C

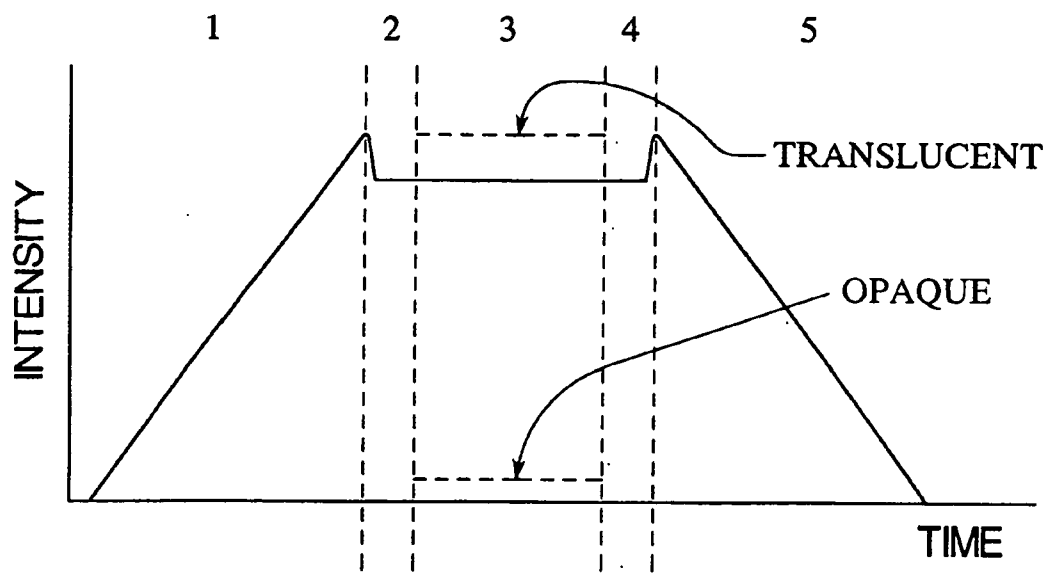

FIG. 5A

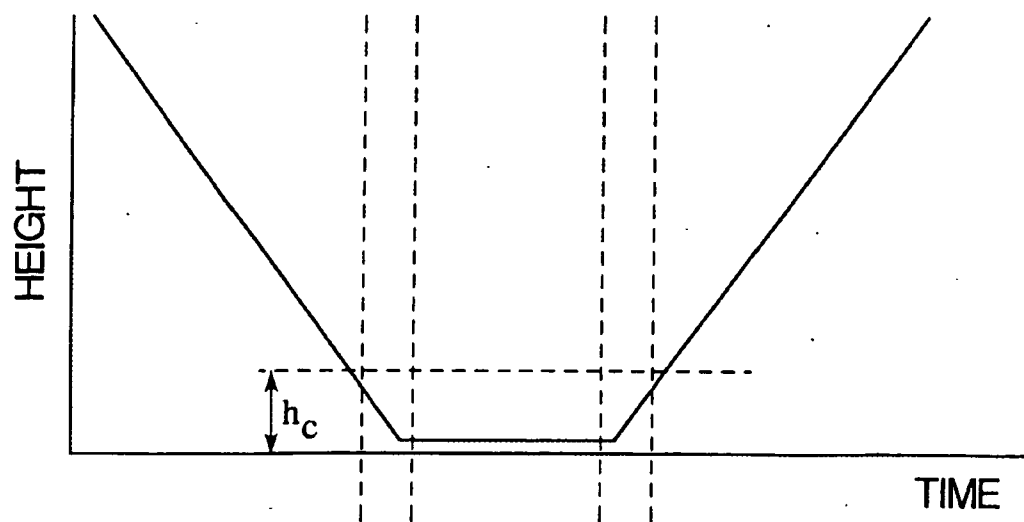
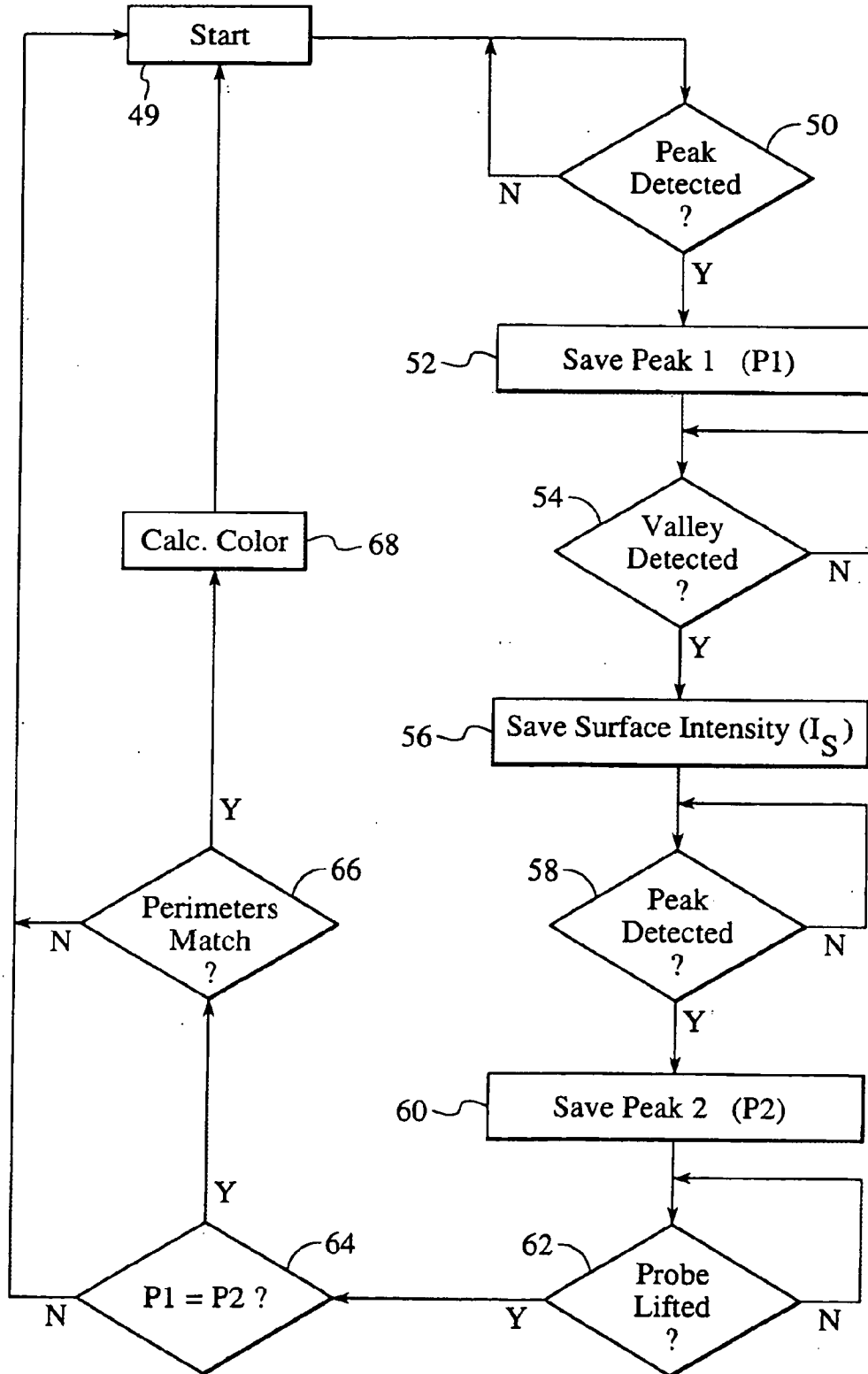

FIG. 5B

FIG. 6



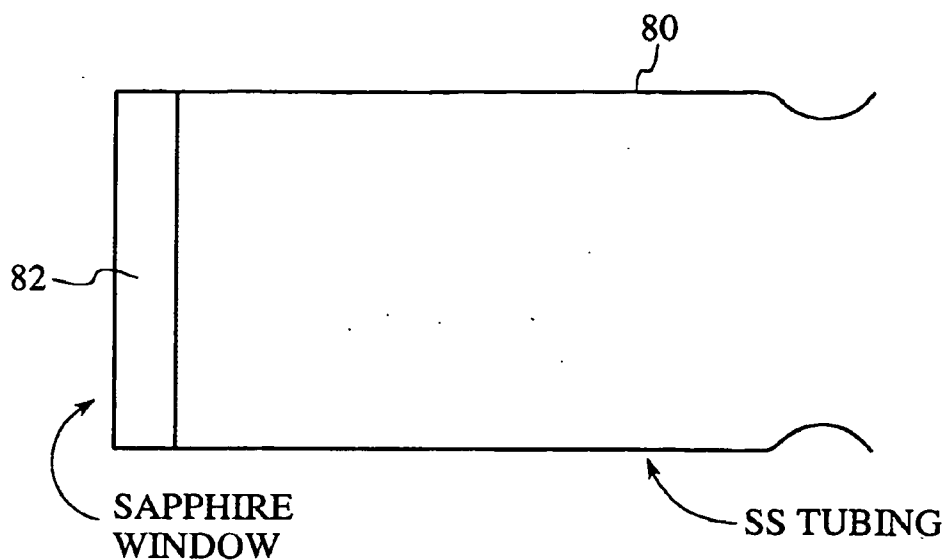

FIG. 7A

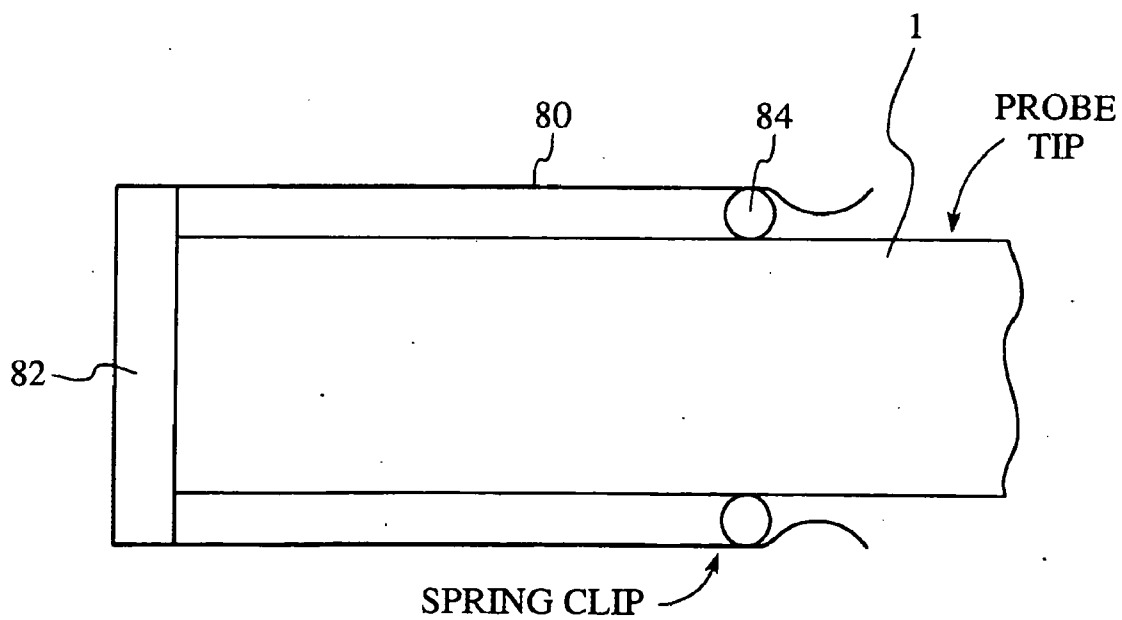

FIG. 7B

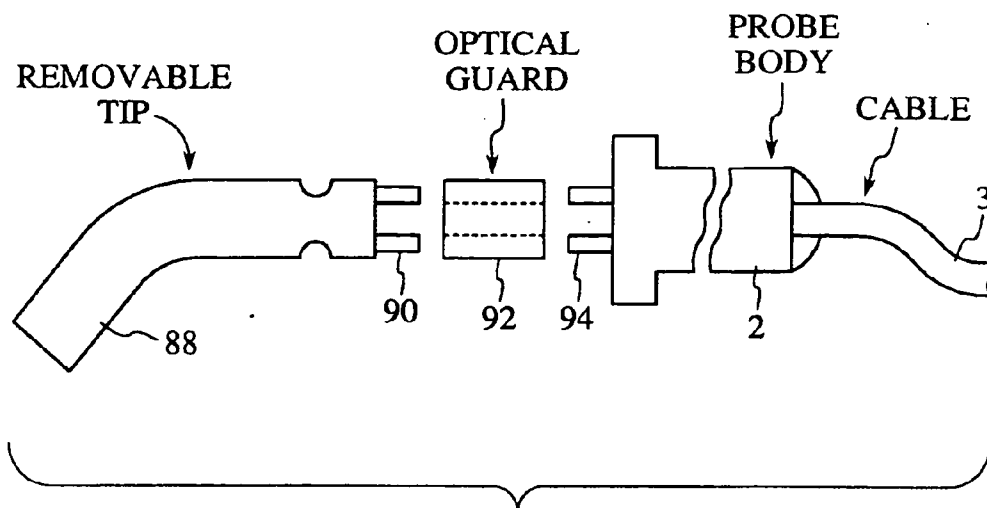

FIG. 8A

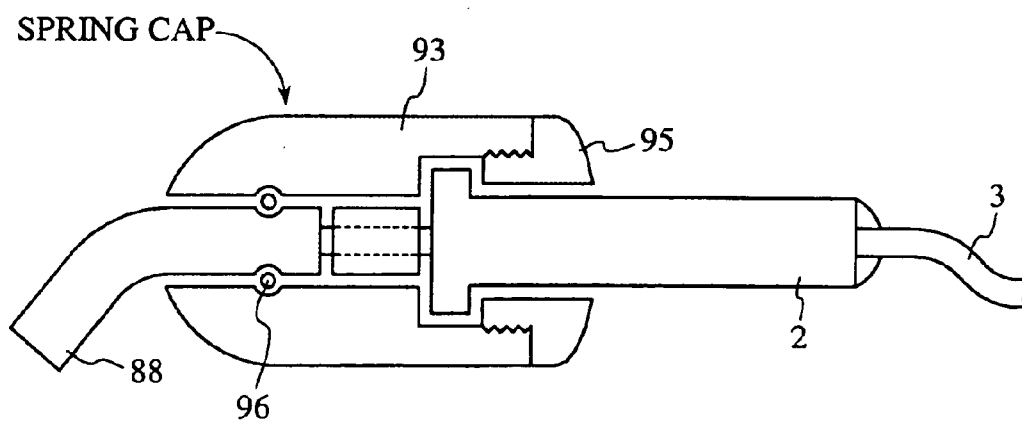
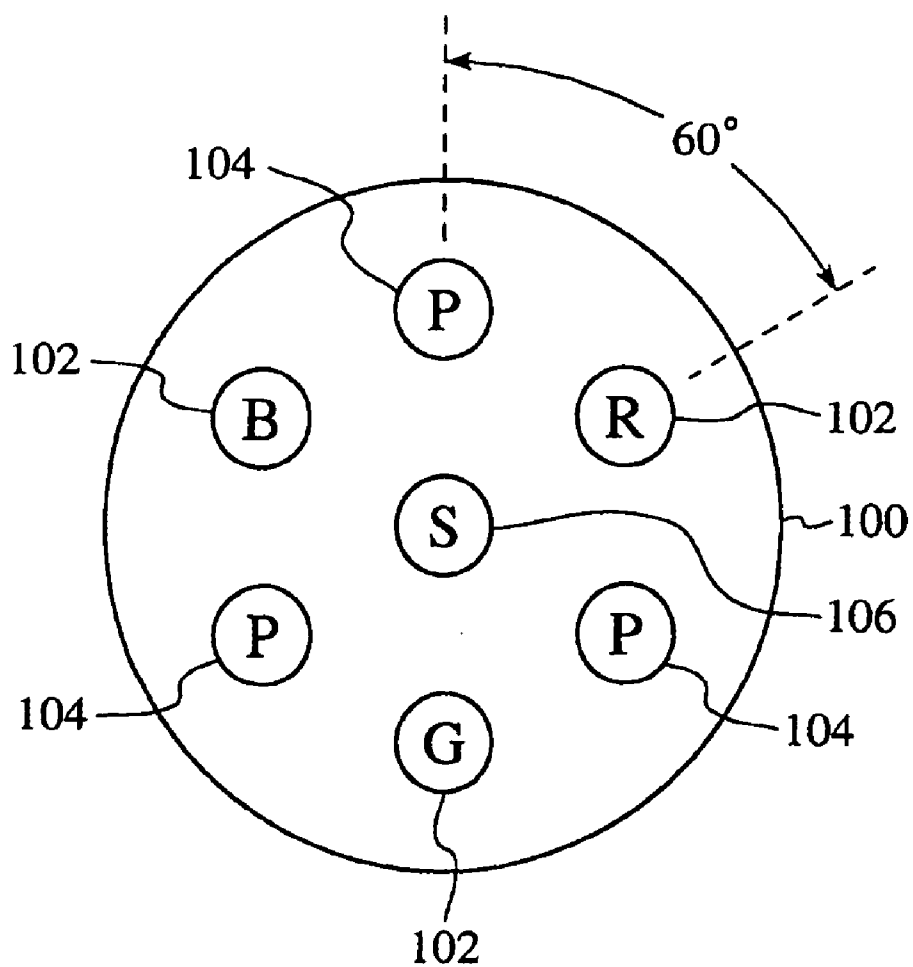

FIG. 8B



S - LIGHT SOURCE FIBER
R - RED RECEIVER
G - GREEN RECEIVER
B - BLUE RECEIVER
P - NEUTRAL (FULL BAND) RECEIVERS

FIG. 9

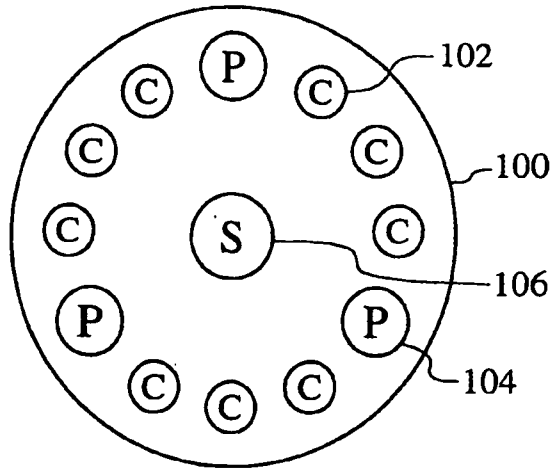

FIG. 10A

S - LIGHT SOURCE FIBER
P - NEUTRAL (FULL BAND) RECEIVER
C - COLOR RECEIVER

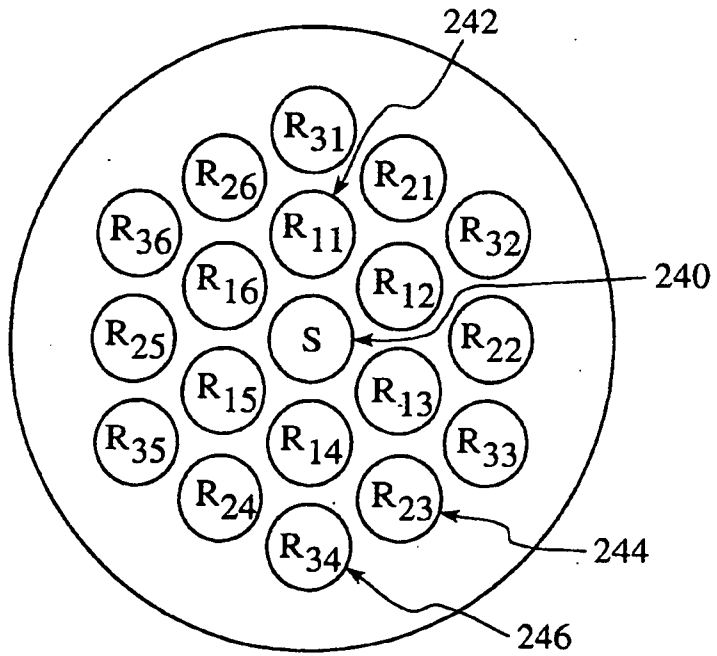

FIG. 10B

S - LIGHT SOURCE FIBER
R_{1X} - INNER RING RECEIVER FIBER
R_{2X} - 2nd RING RECEIVER FIBER
R_{3X} - 3rd RING RECEIVER FIBER

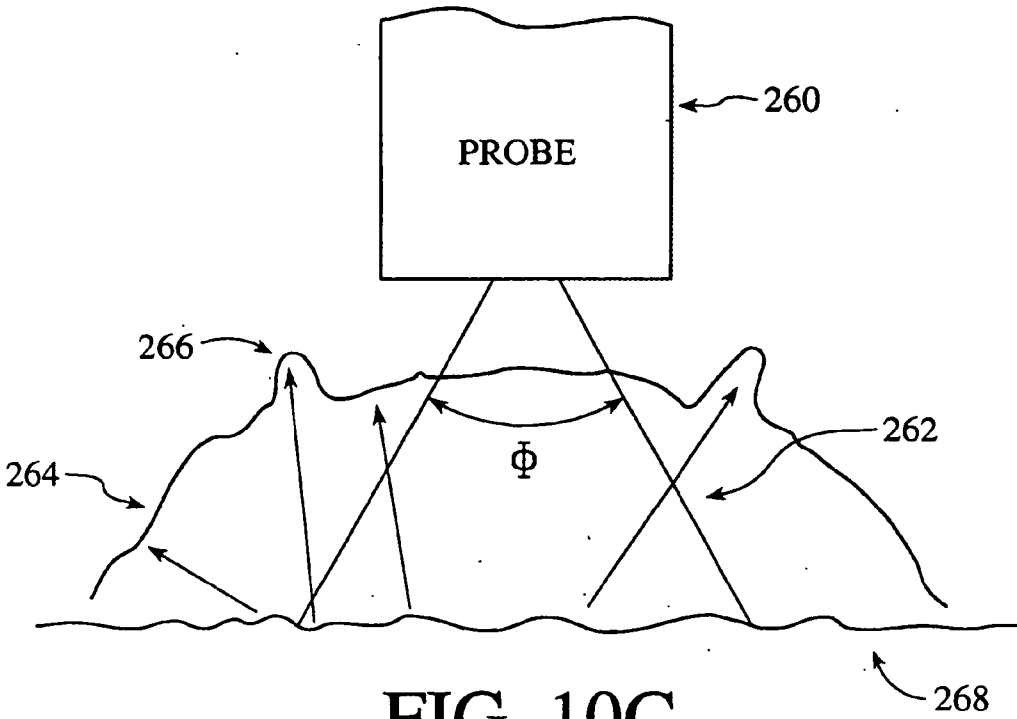

FIG. 10C

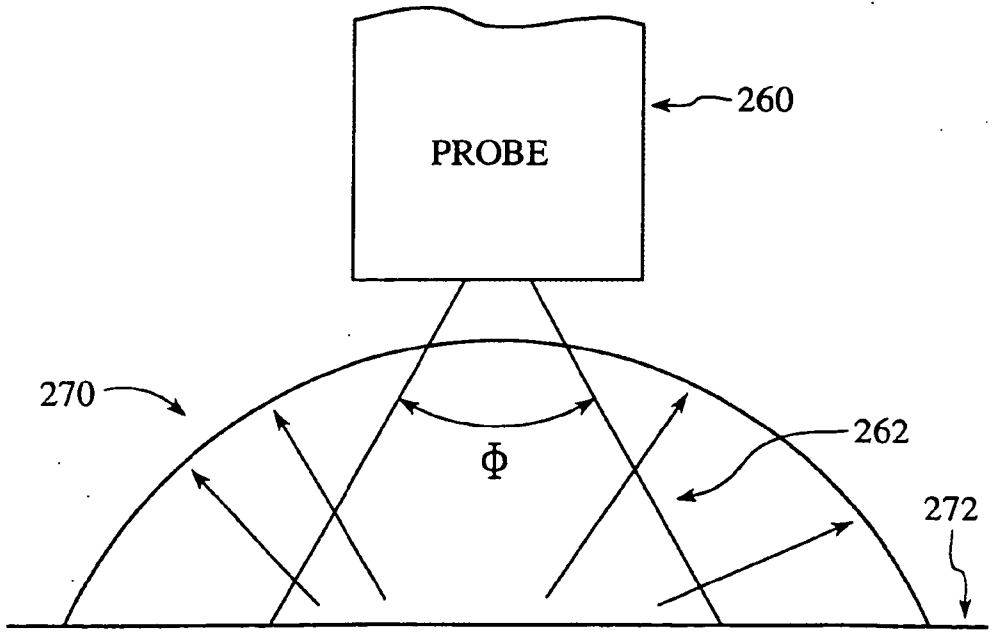

FIG. 10D

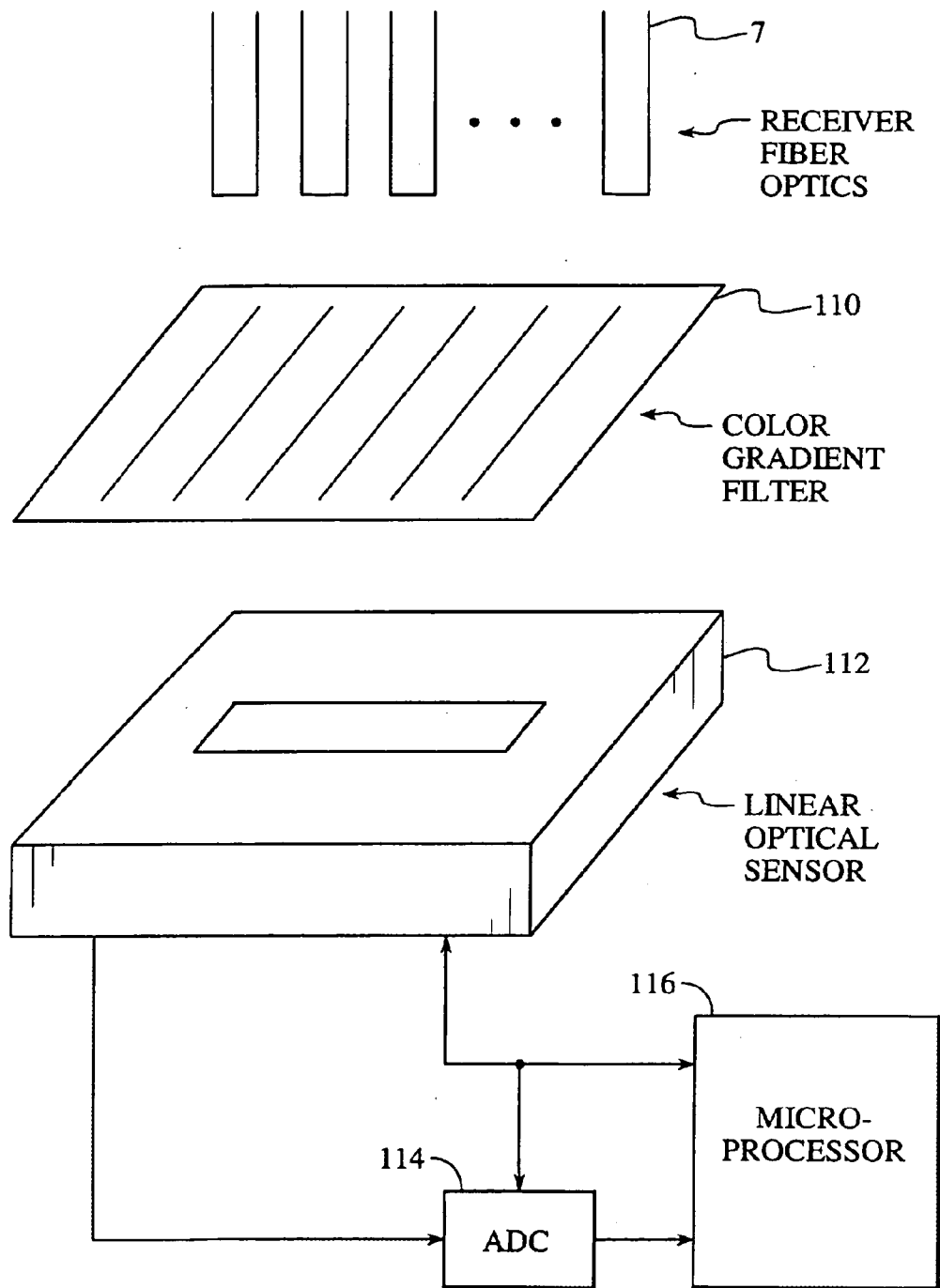

FIG. 11

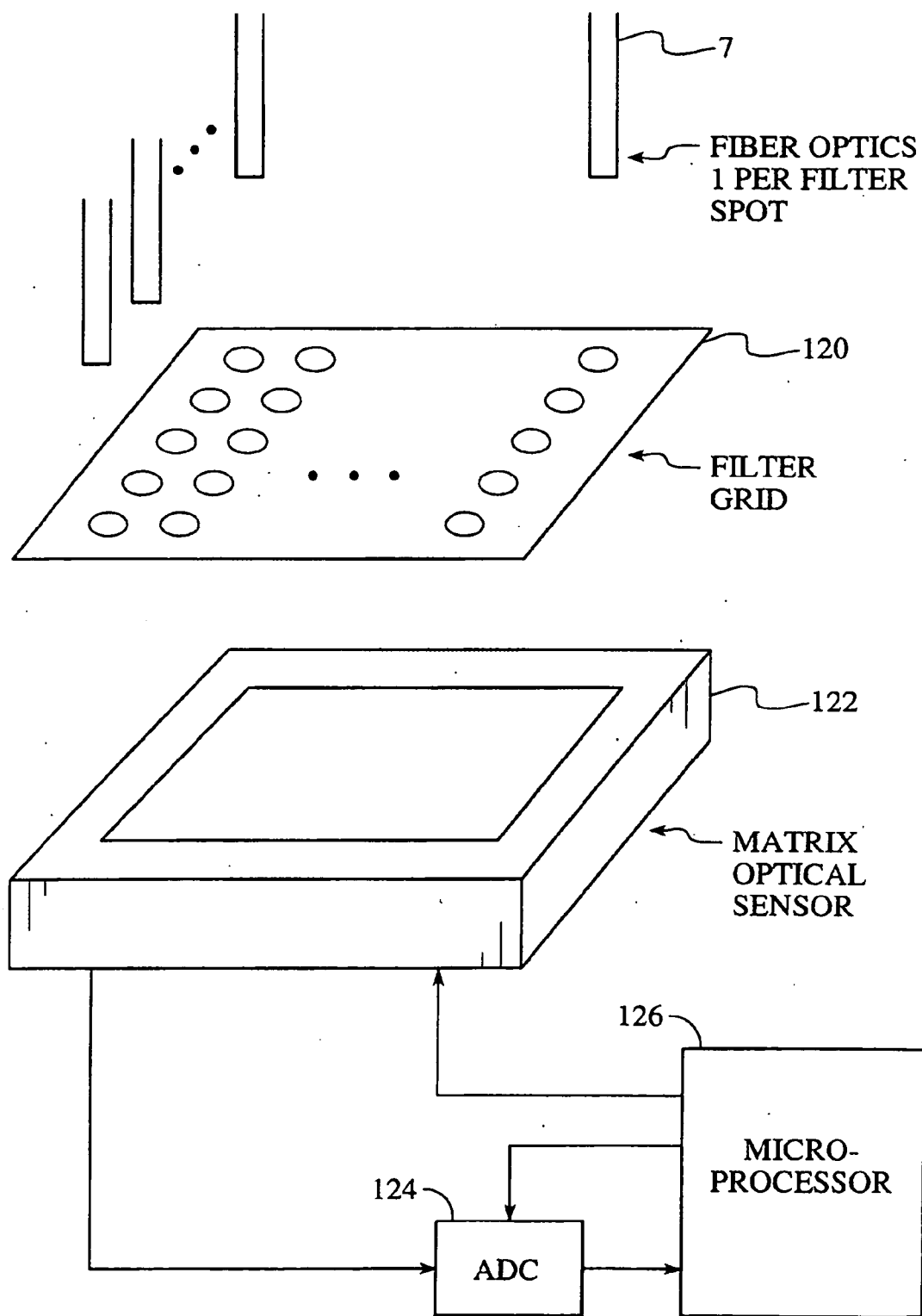

FIG. 12

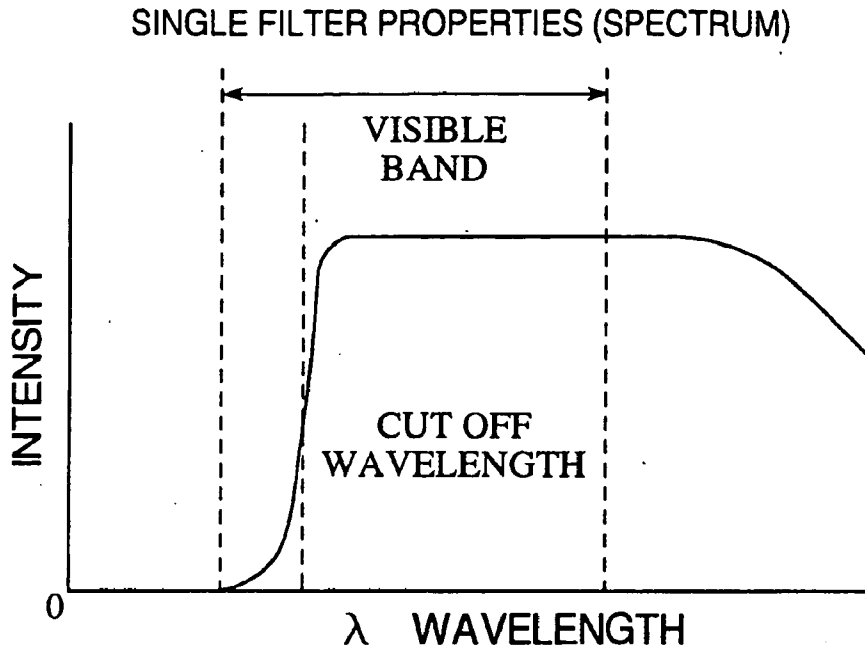

FIG. 13A

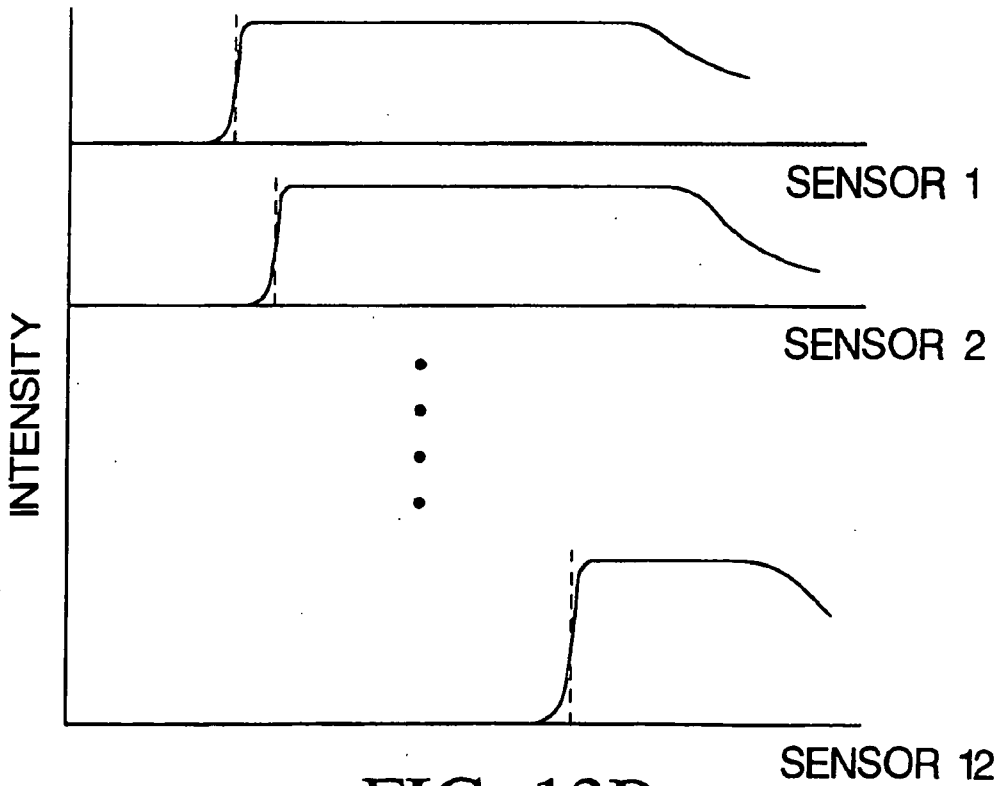

FIG. 13B

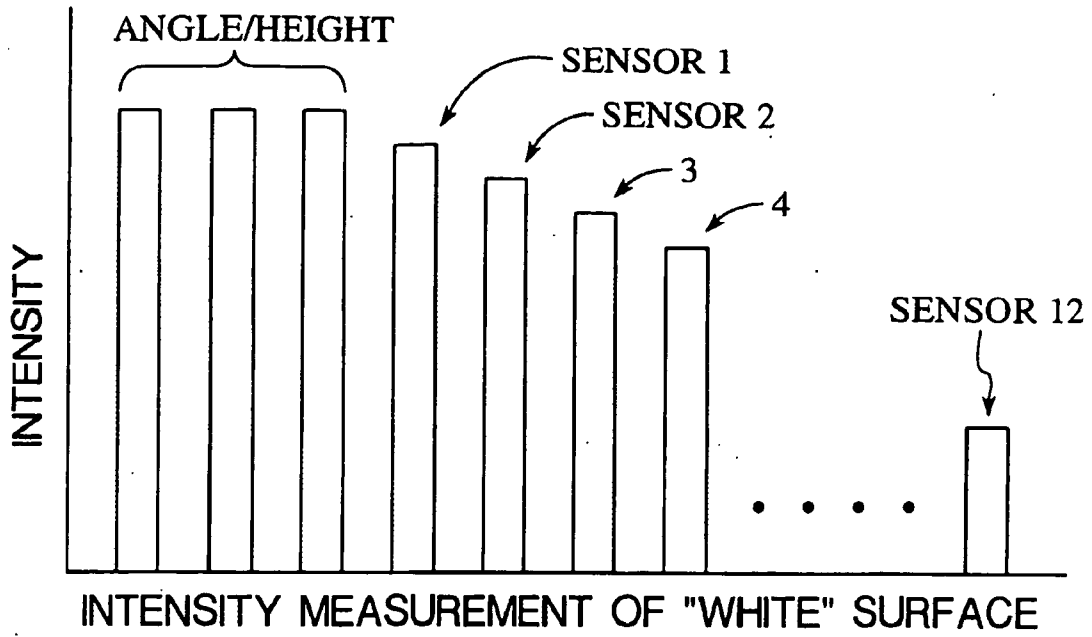

FIG. 14A

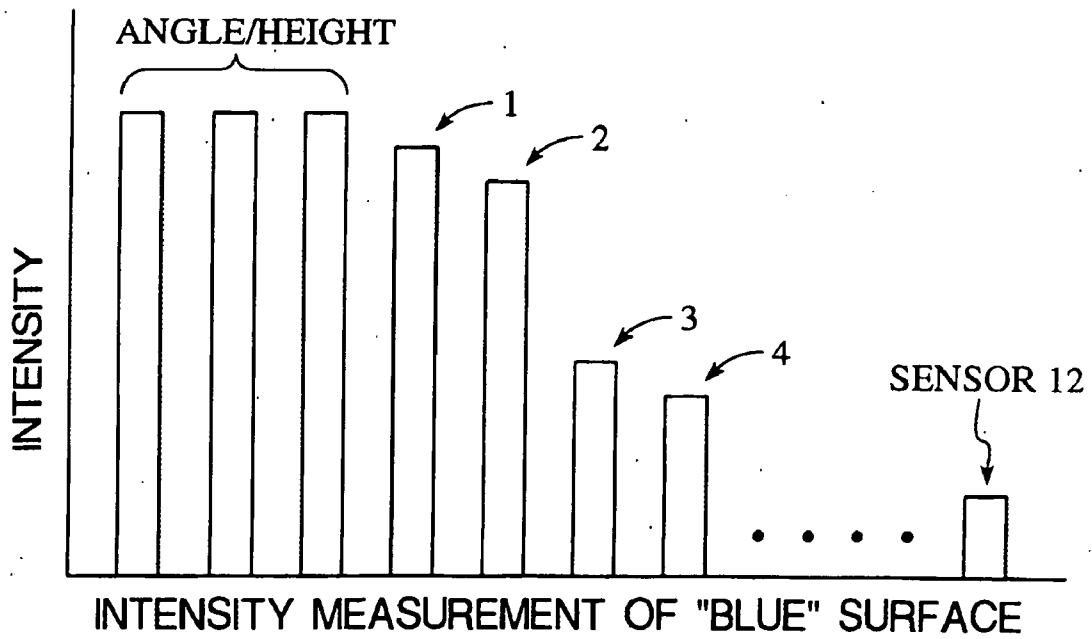

FIG. 14B

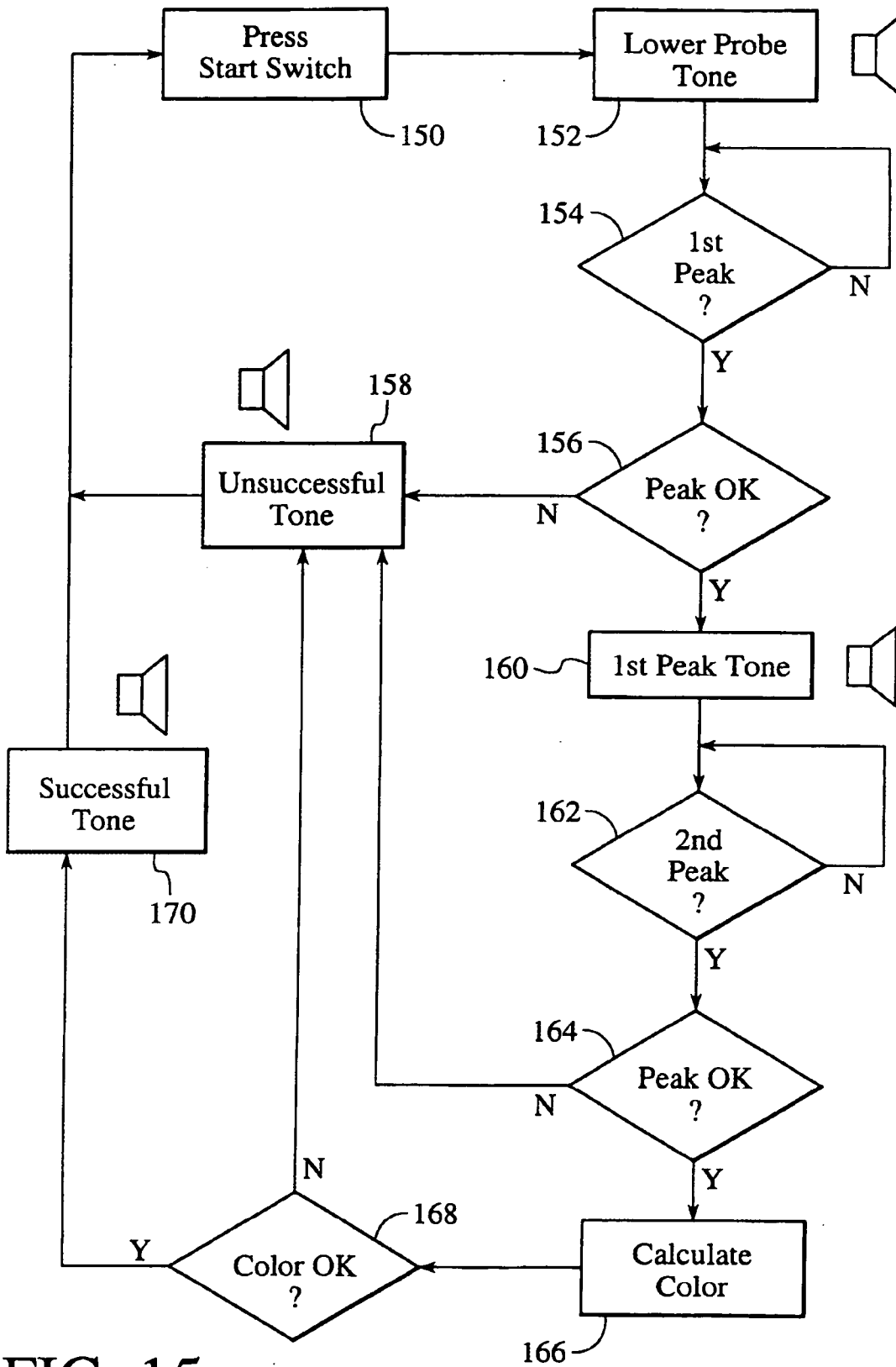

FIG. 15

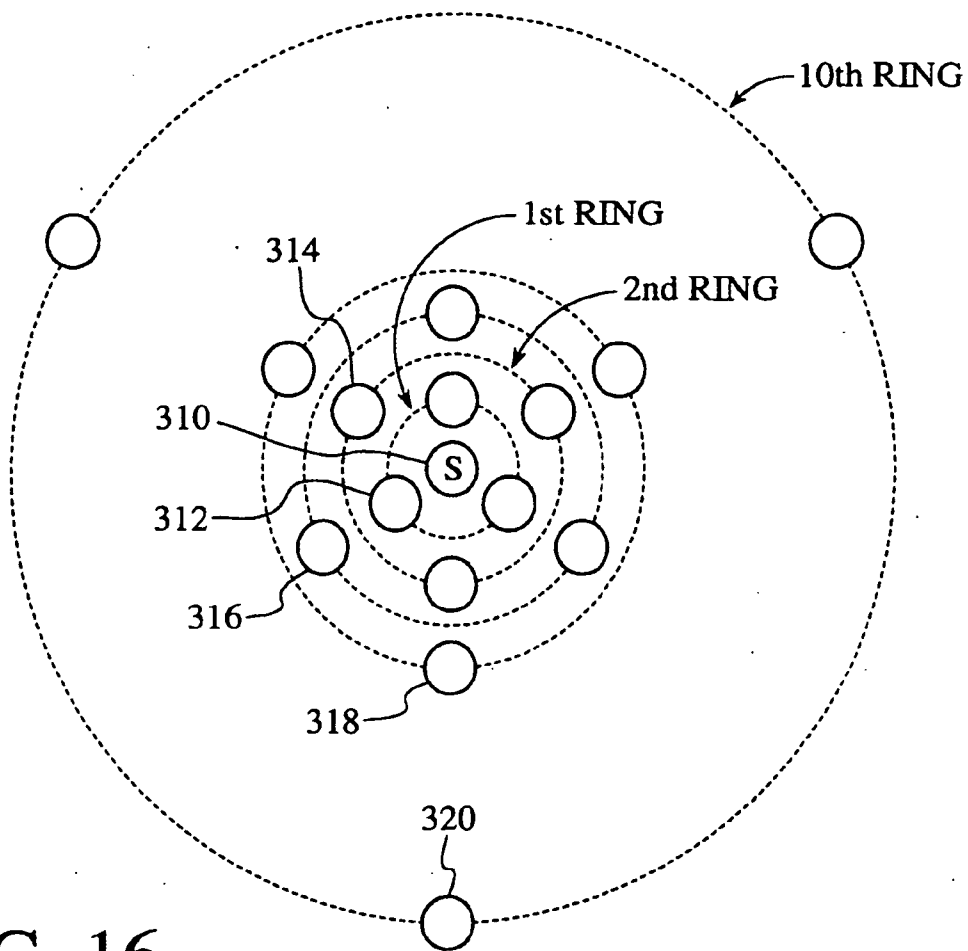

FIG. 16

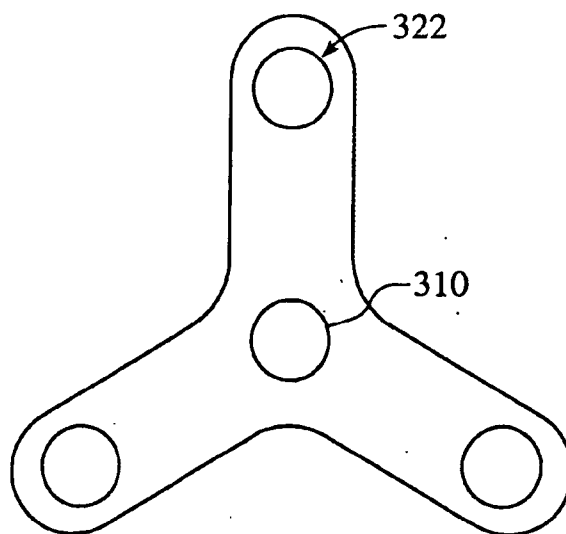

FIG. 17

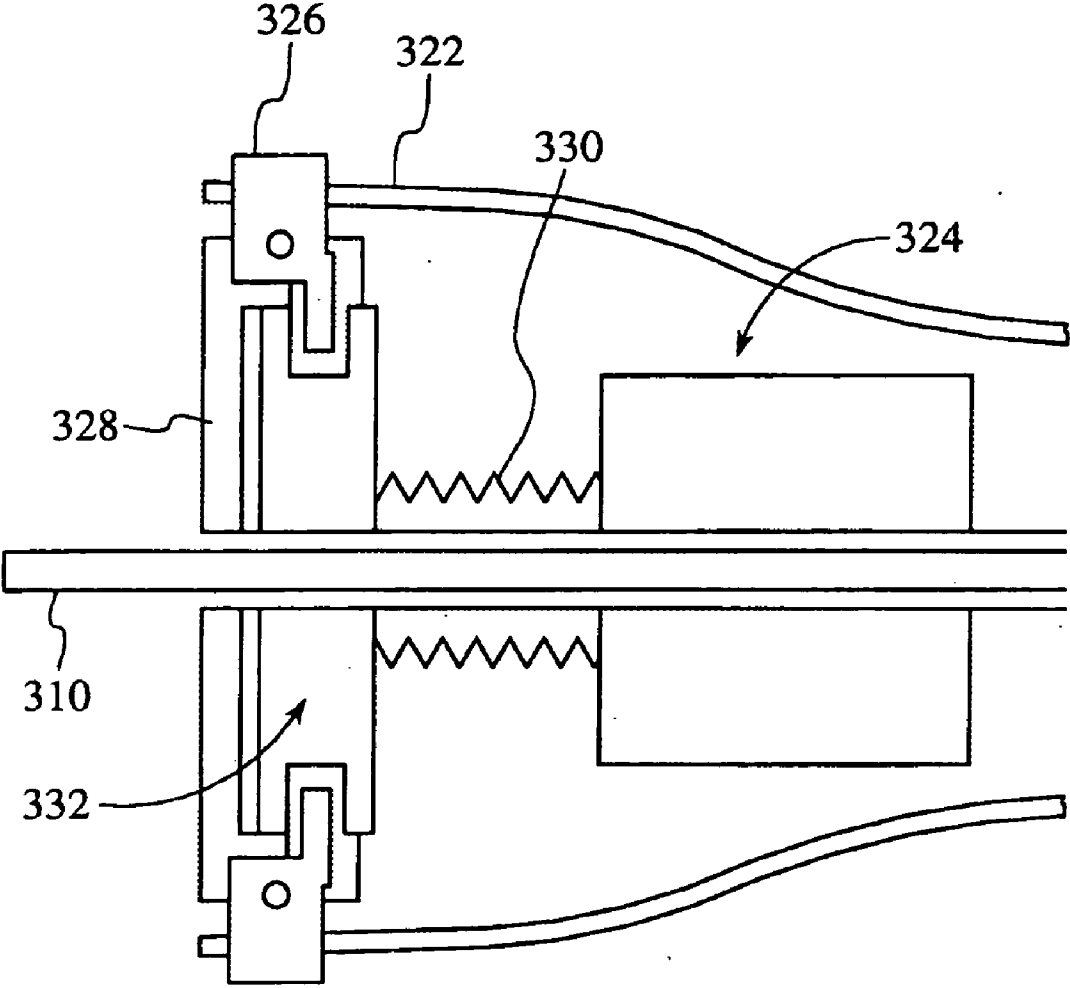

FIG. 18

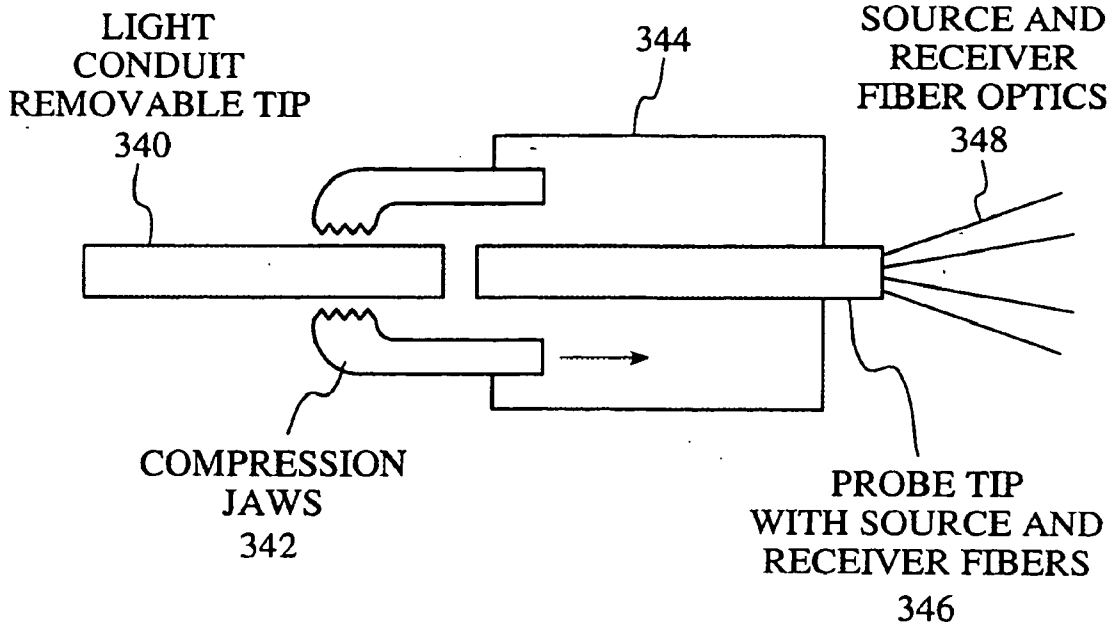

FIG. 19A

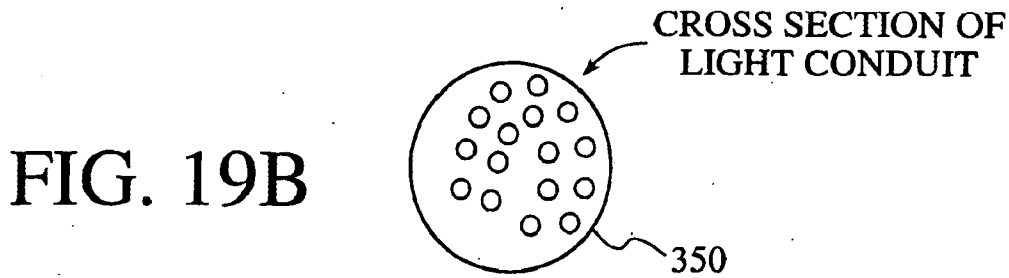

FIG. 19B

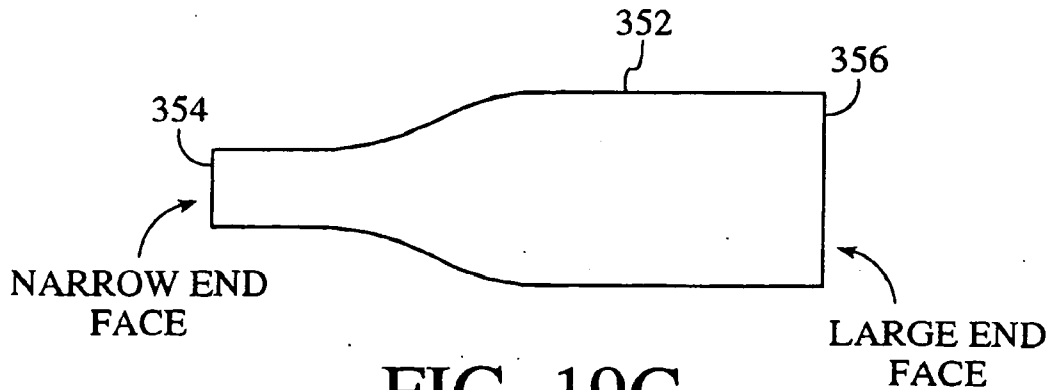

FIG. 19C

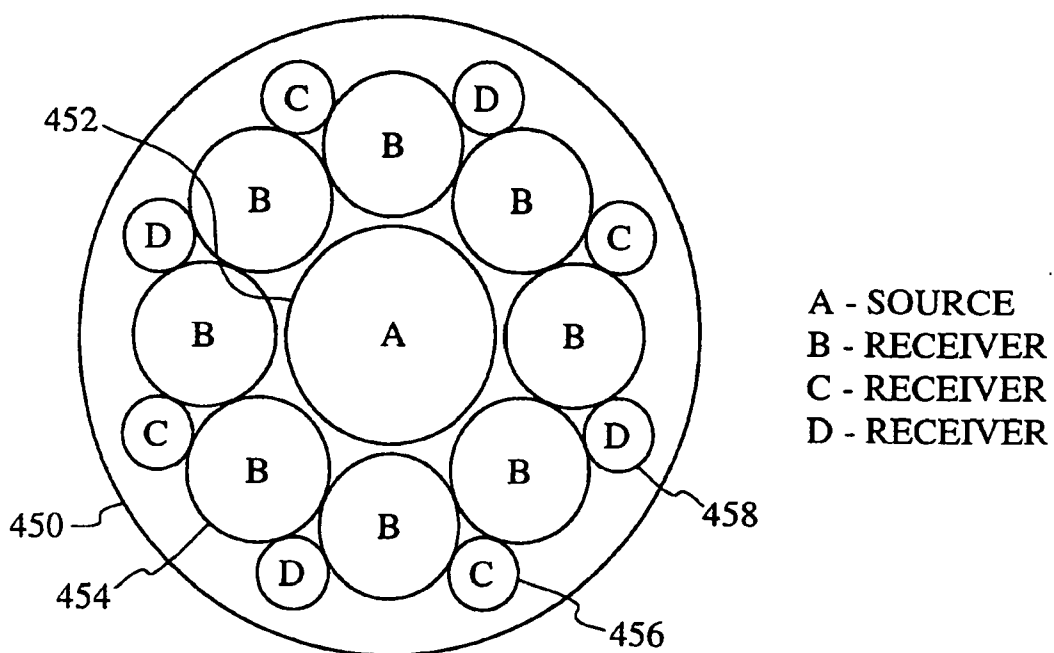

FIG. 20A

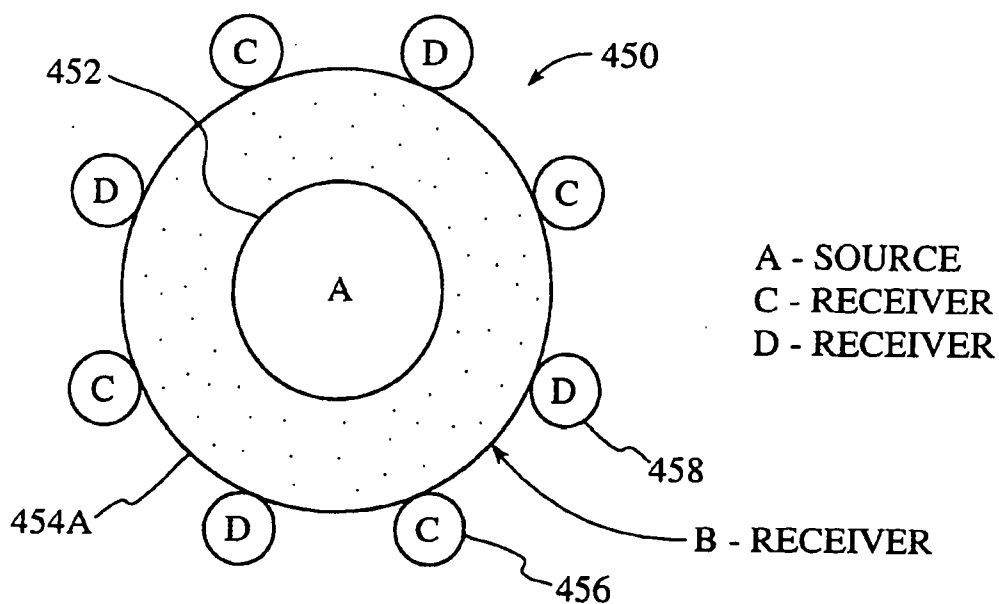

FIG. 20B

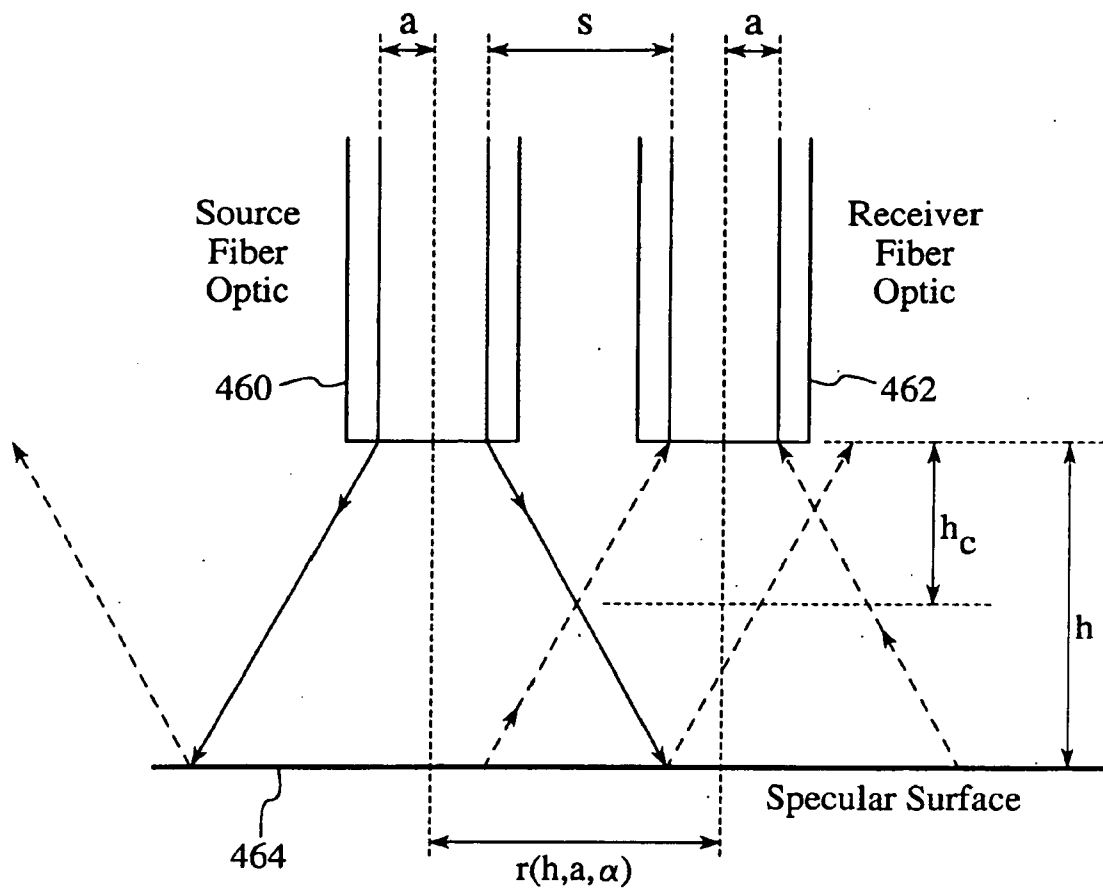

FIG. 21

FIG. 22A

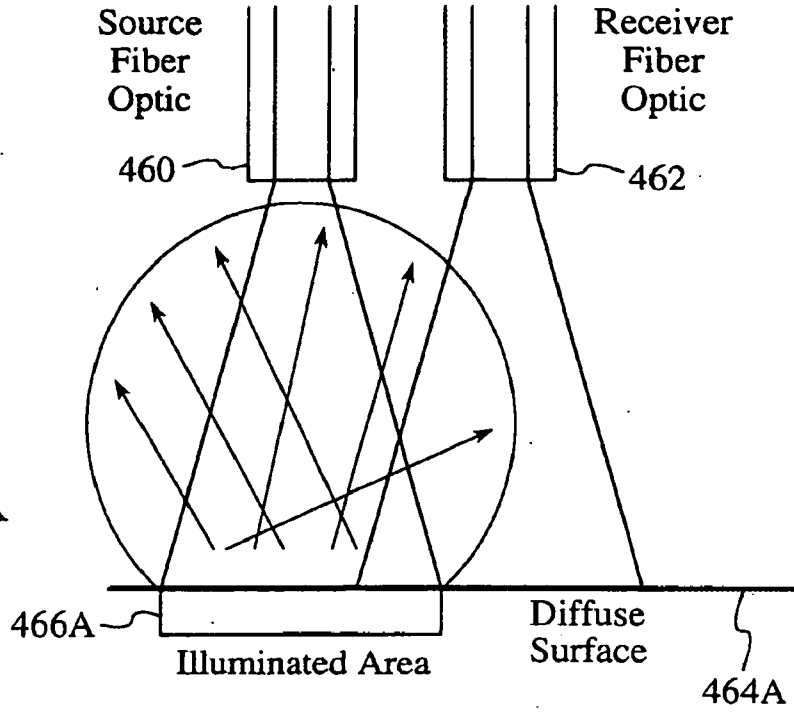
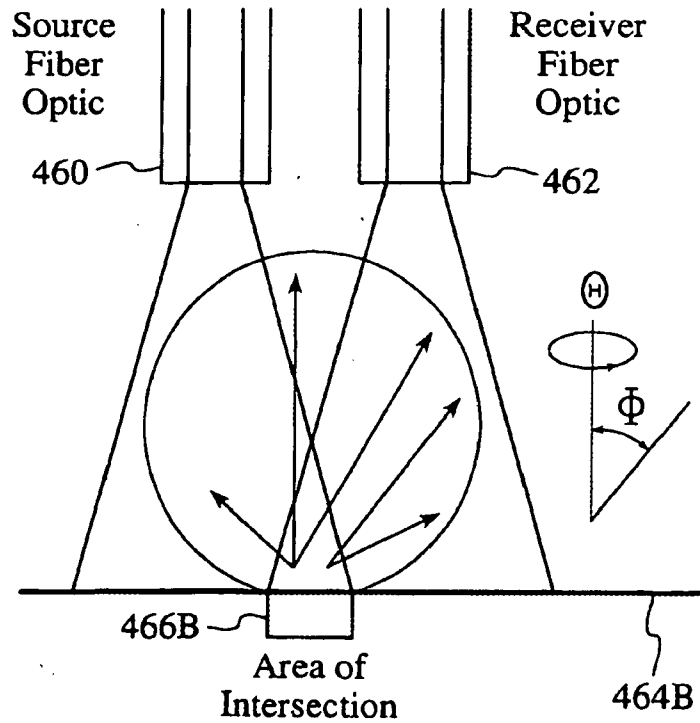

FIG. 22B



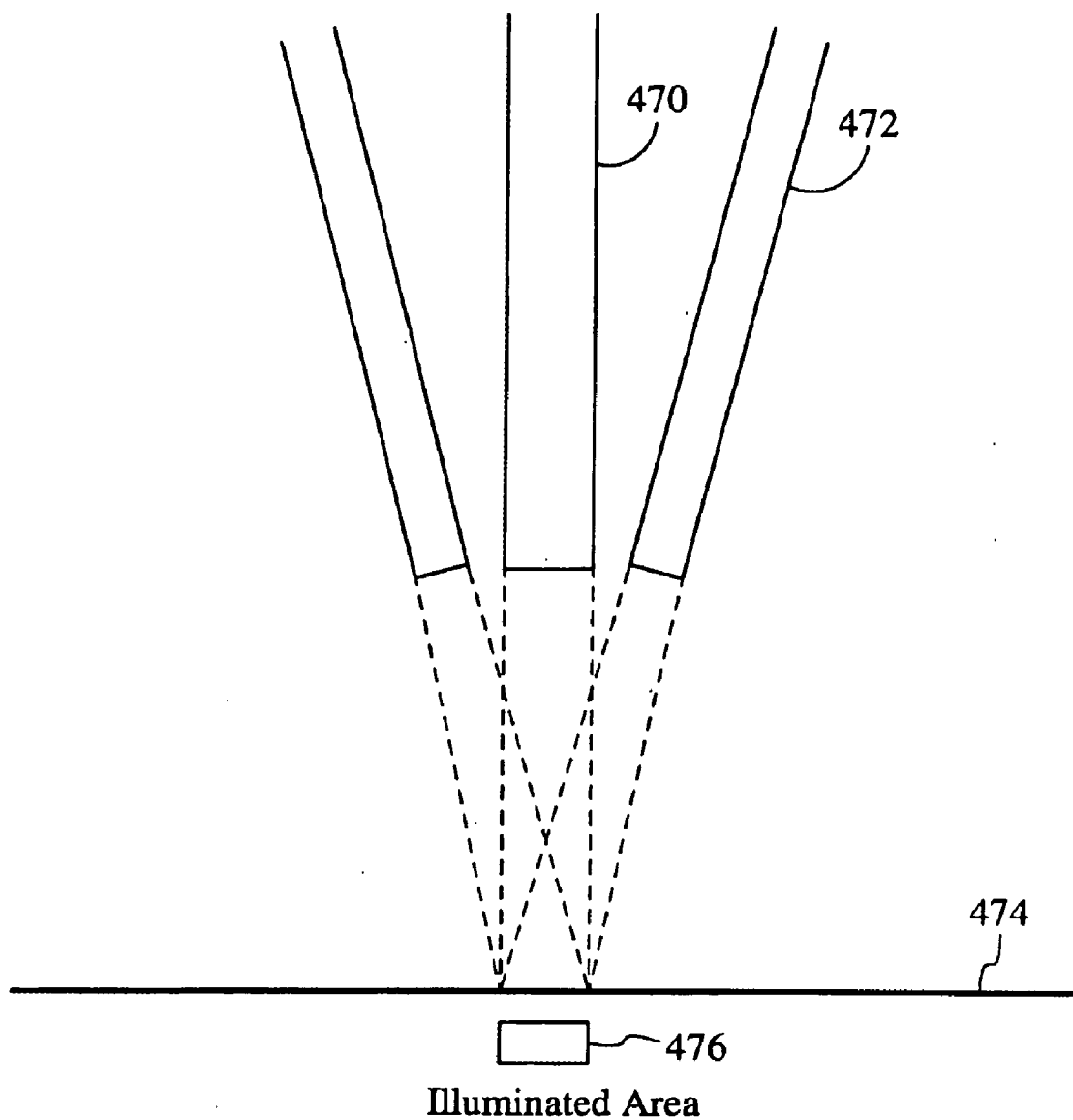

FIG. 23A

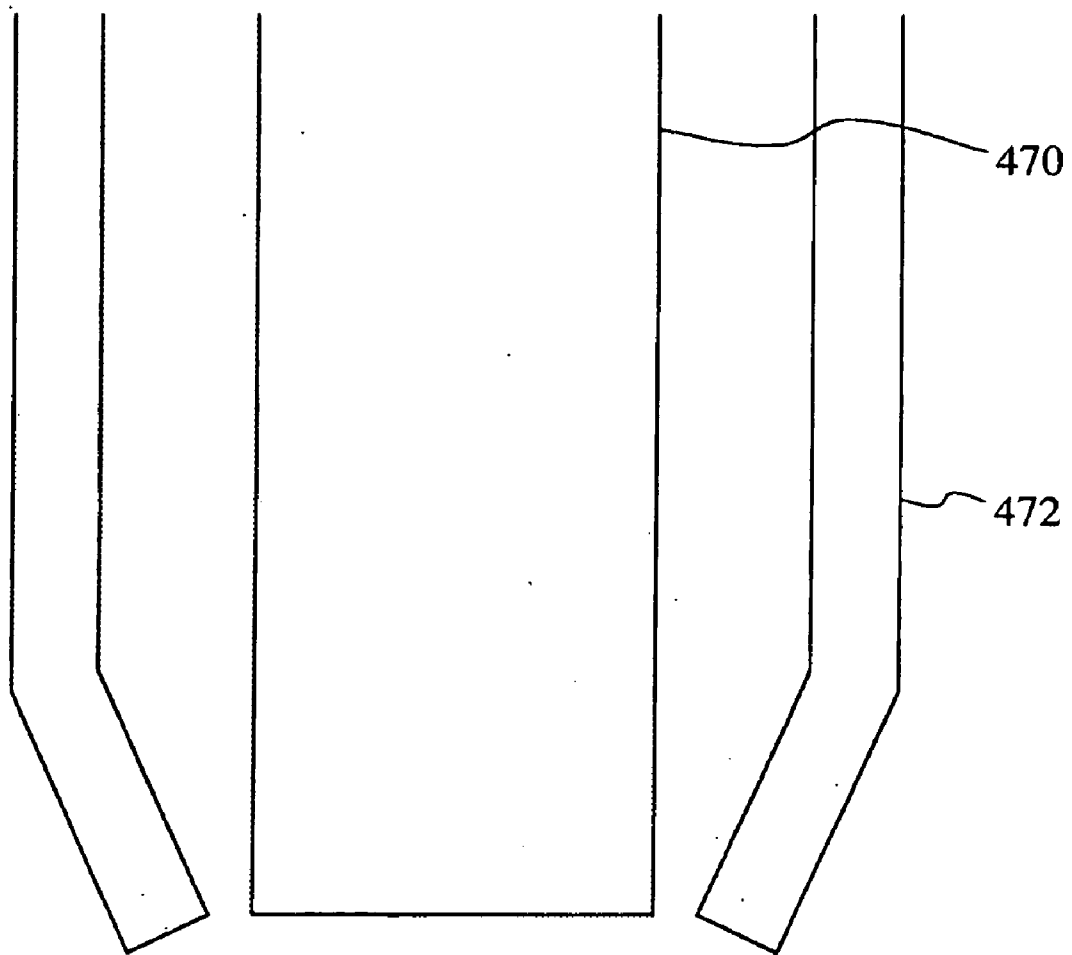

FIG. 23B

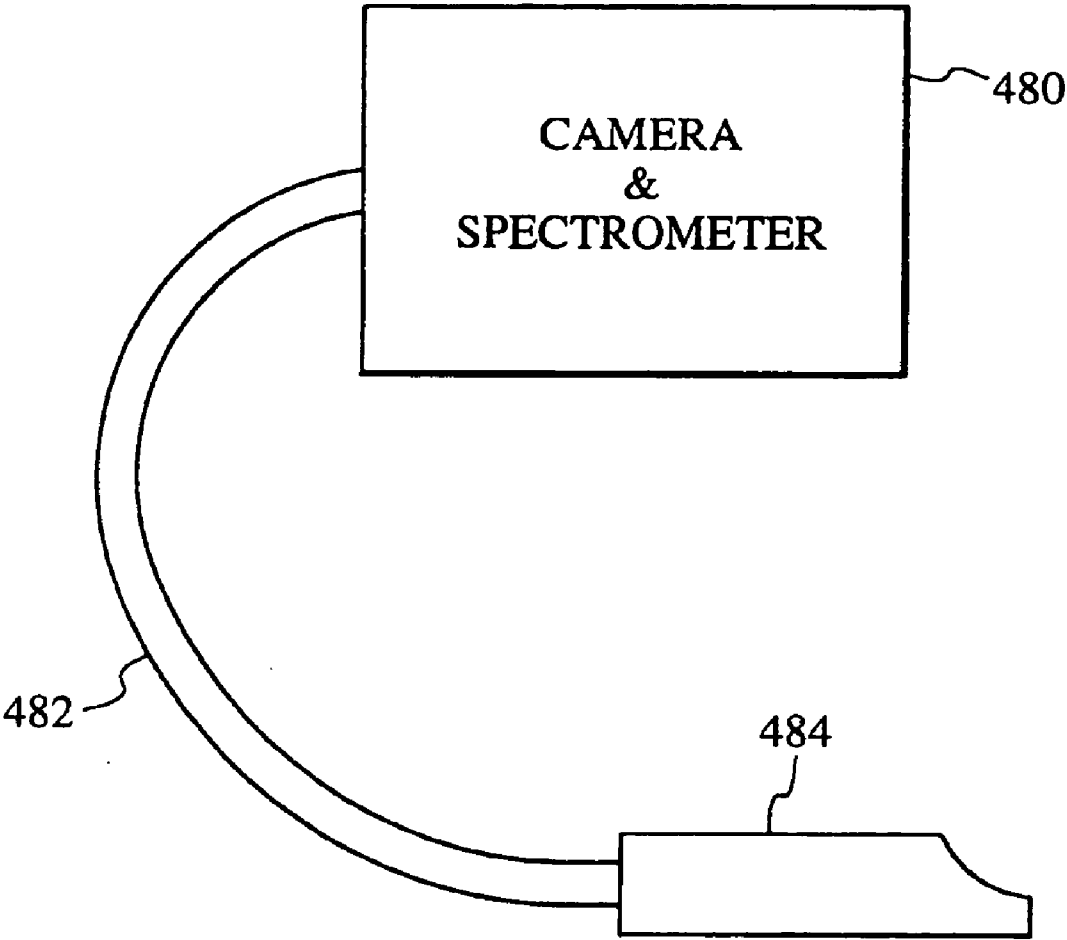

FIG. 24

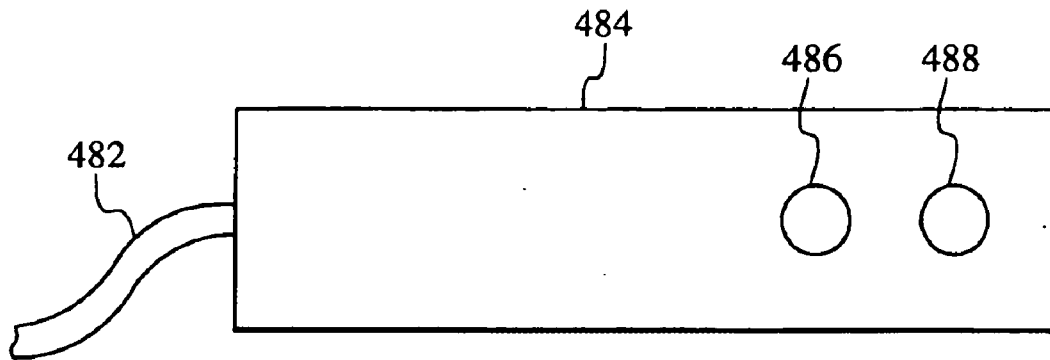

FIG. 25

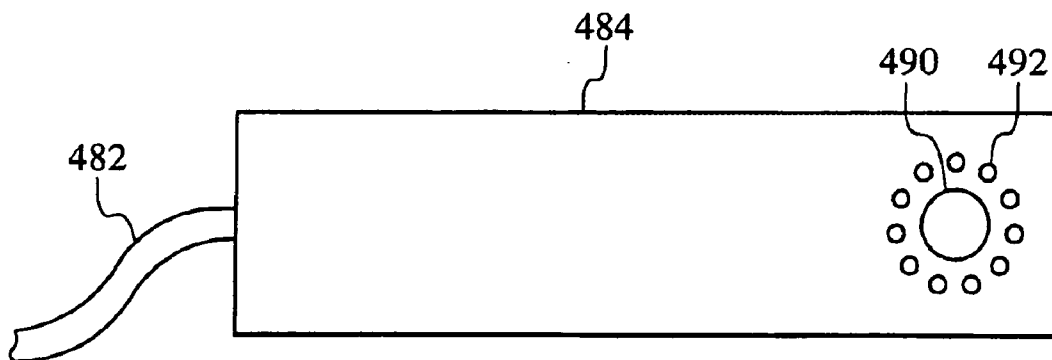

FIG. 26

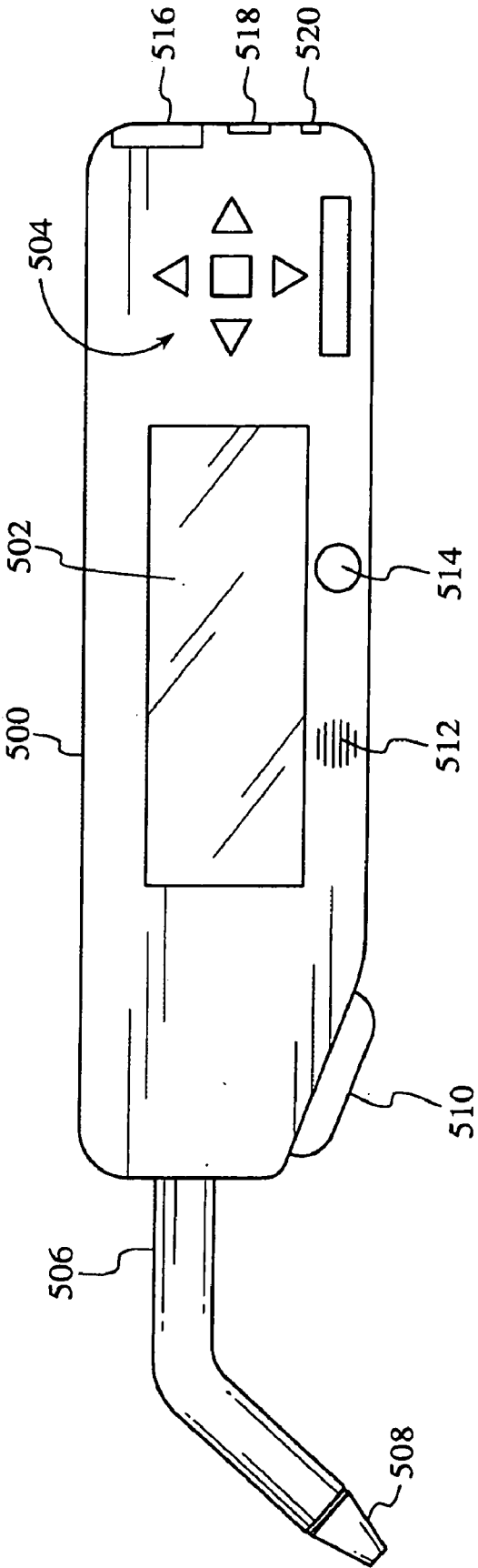
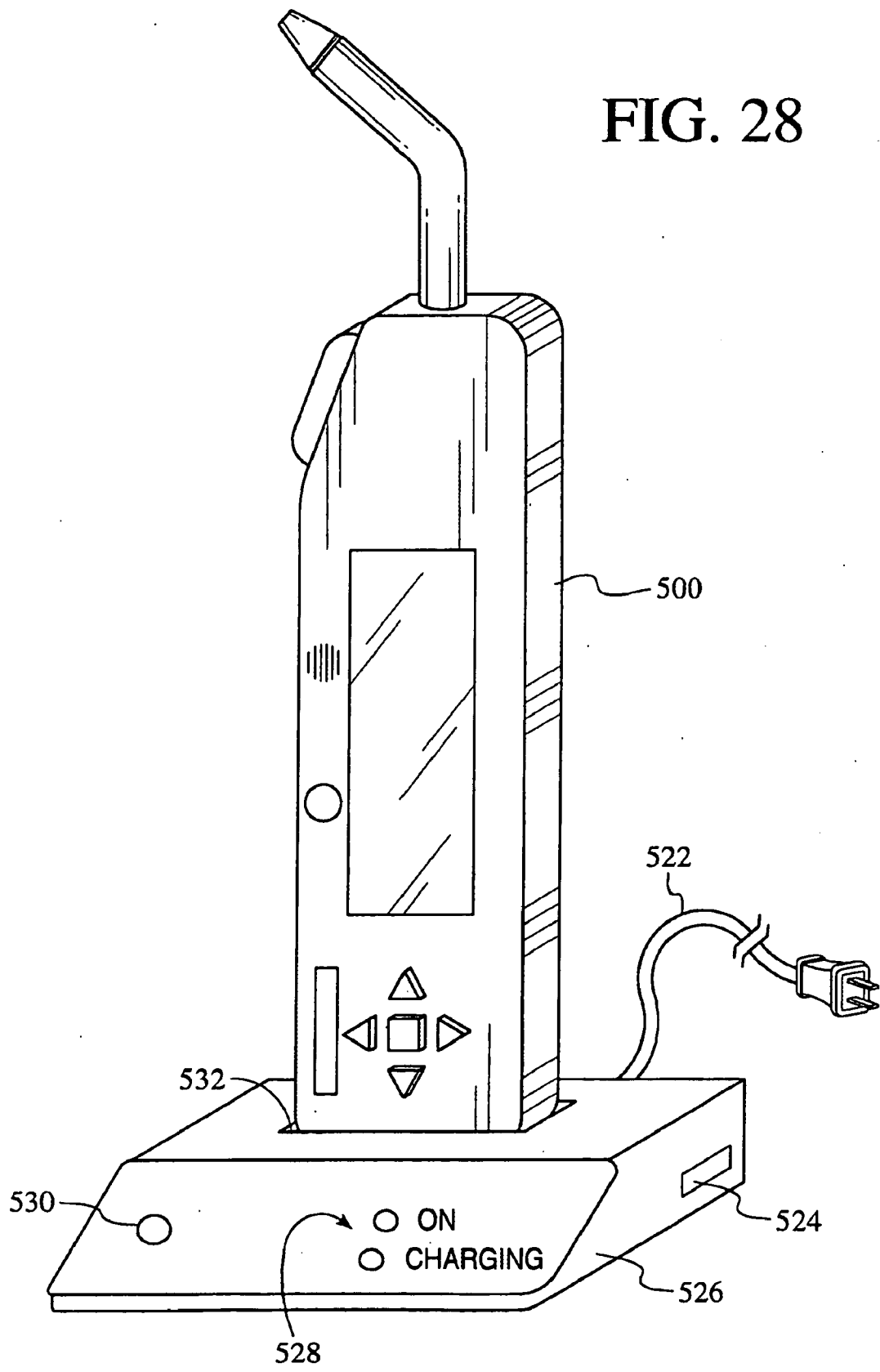

FIG. 27

FIG. 28



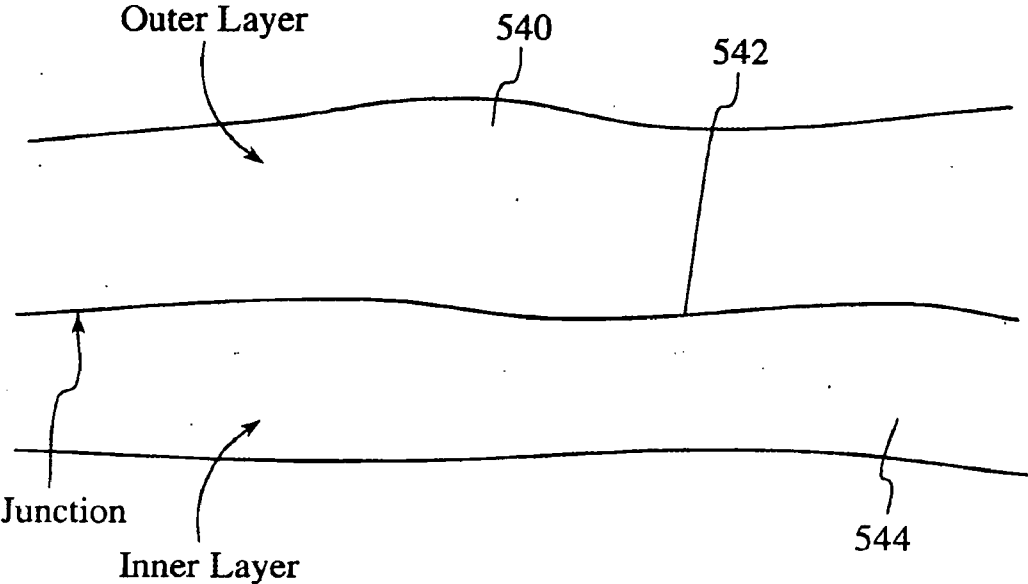
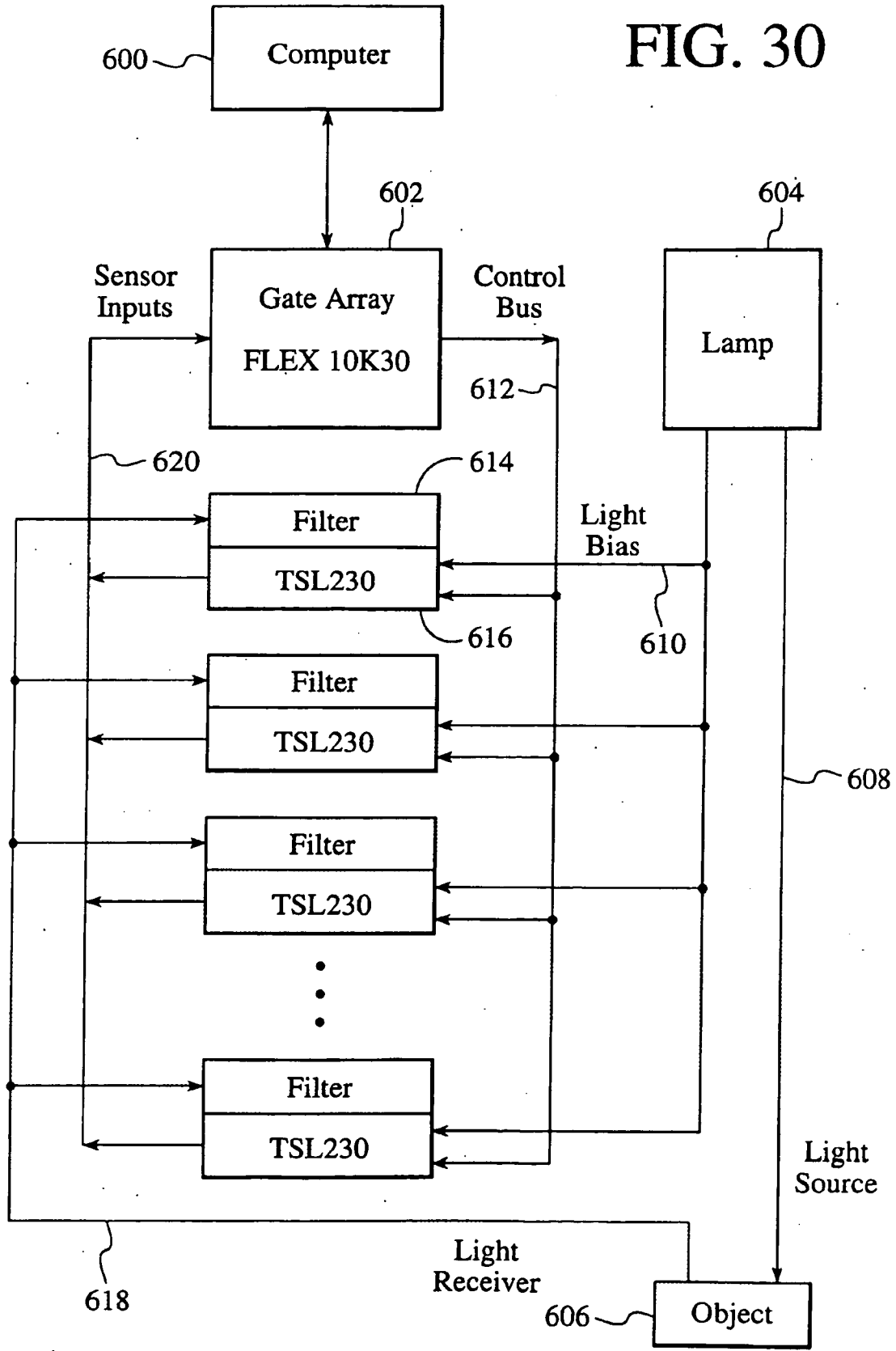

FIG. 29

FIG. 30



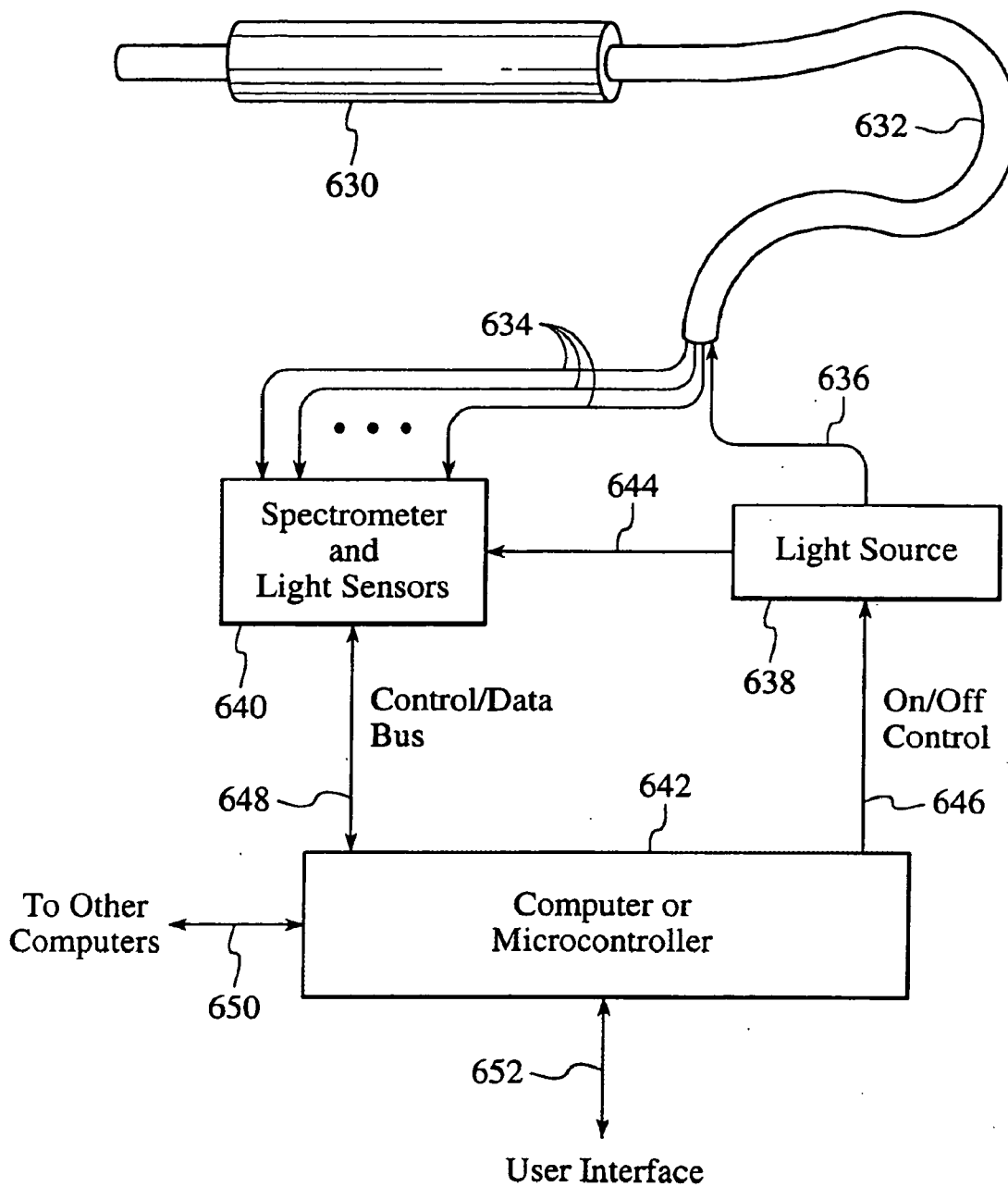

FIG. 31

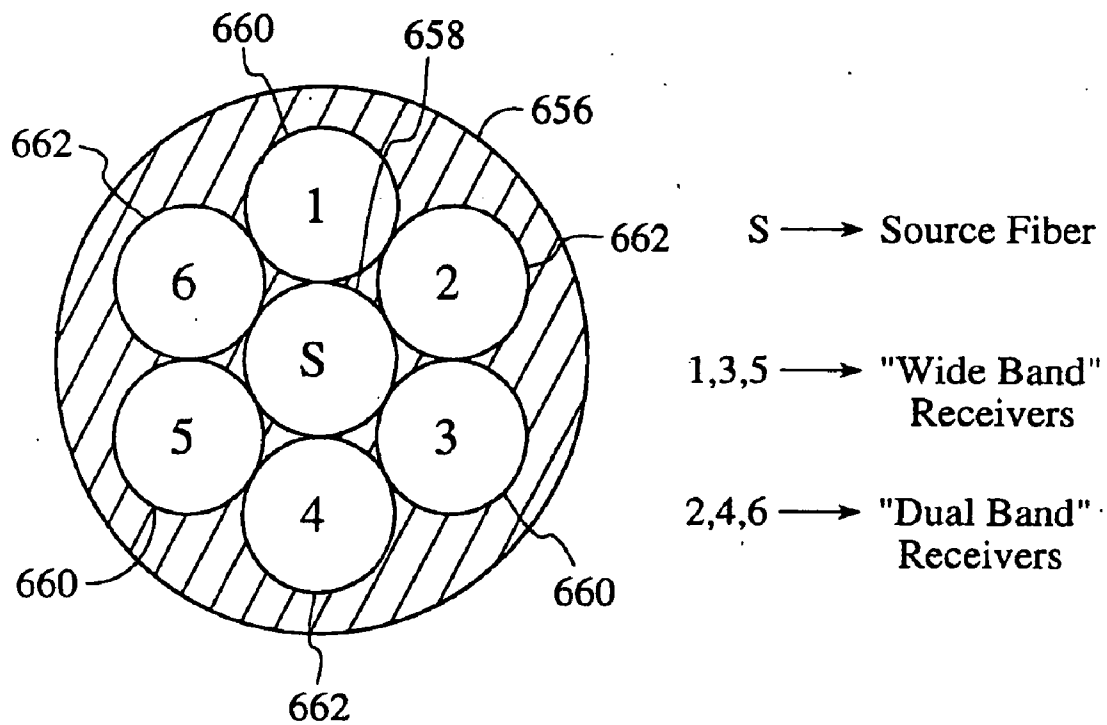

FIG. 32

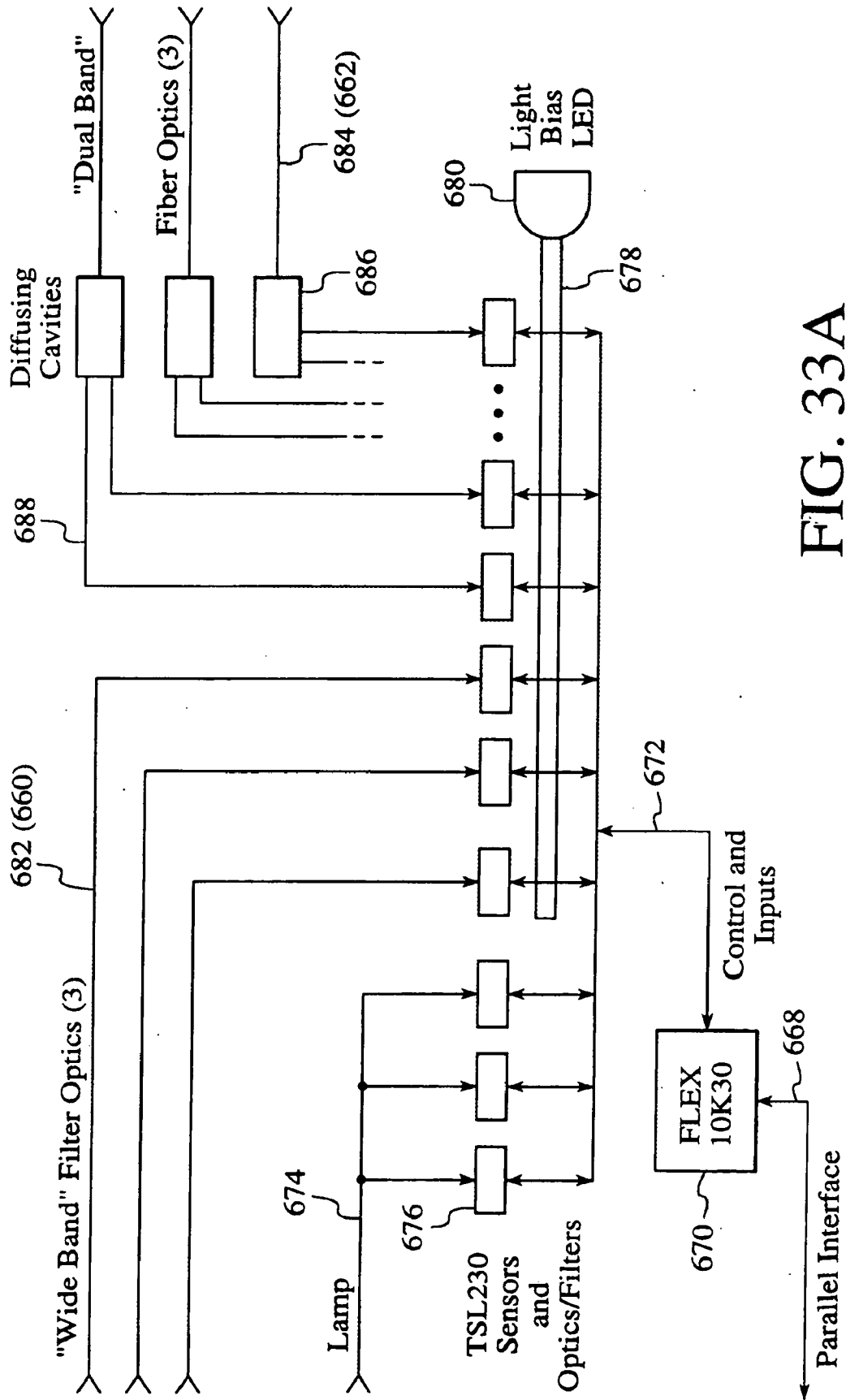

FIG. 33A

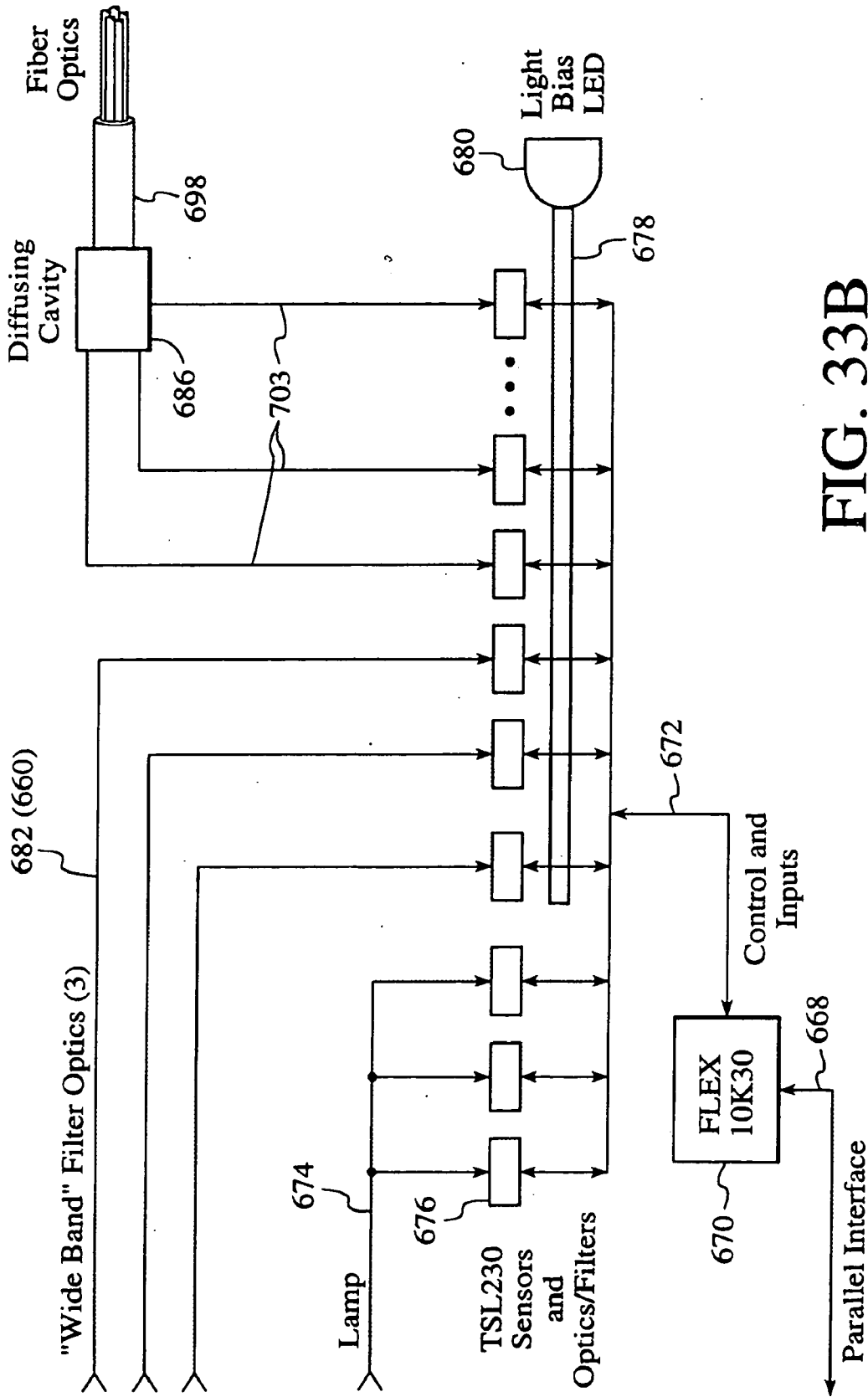

FIG. 33B

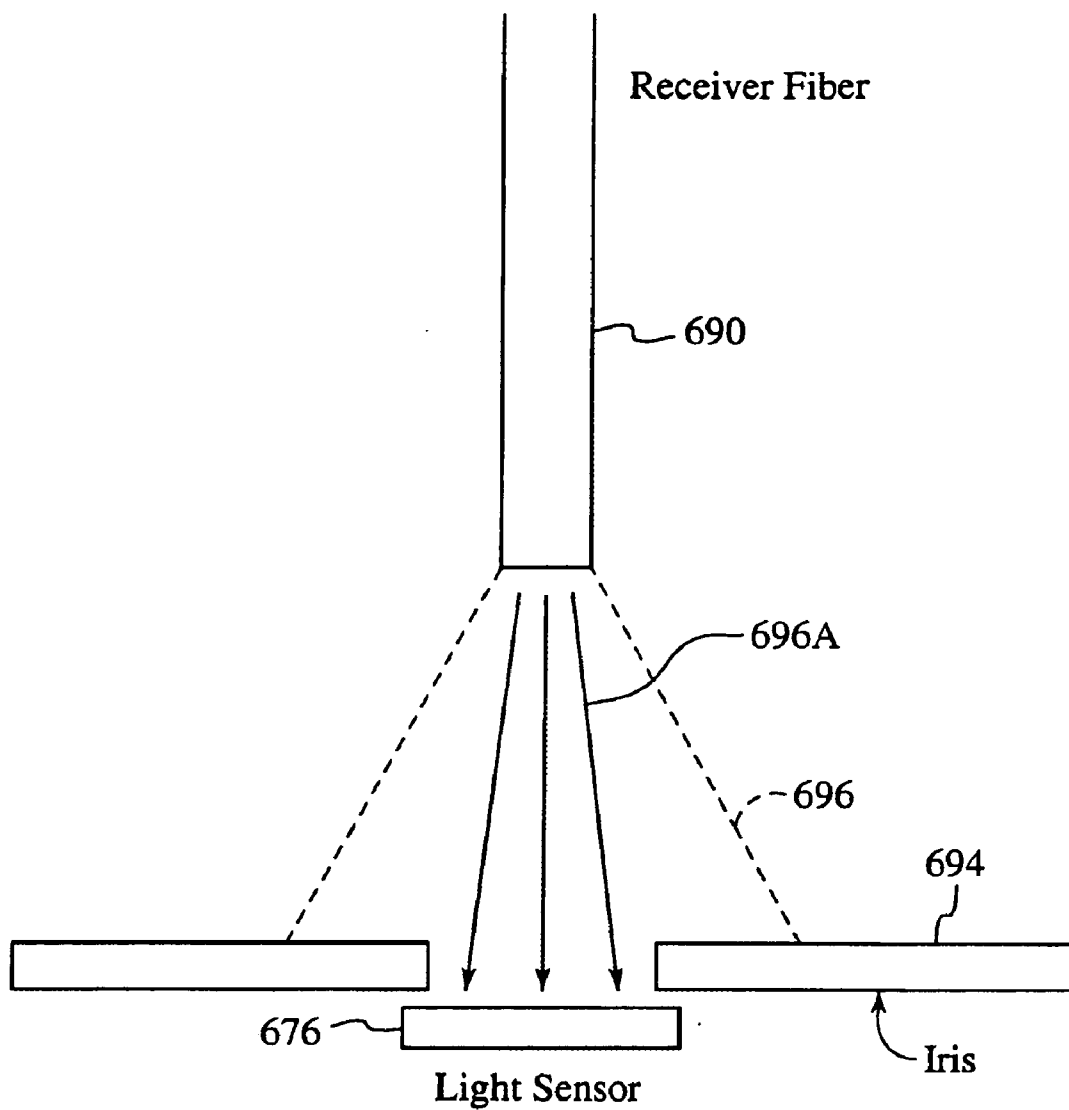

FIG. 34

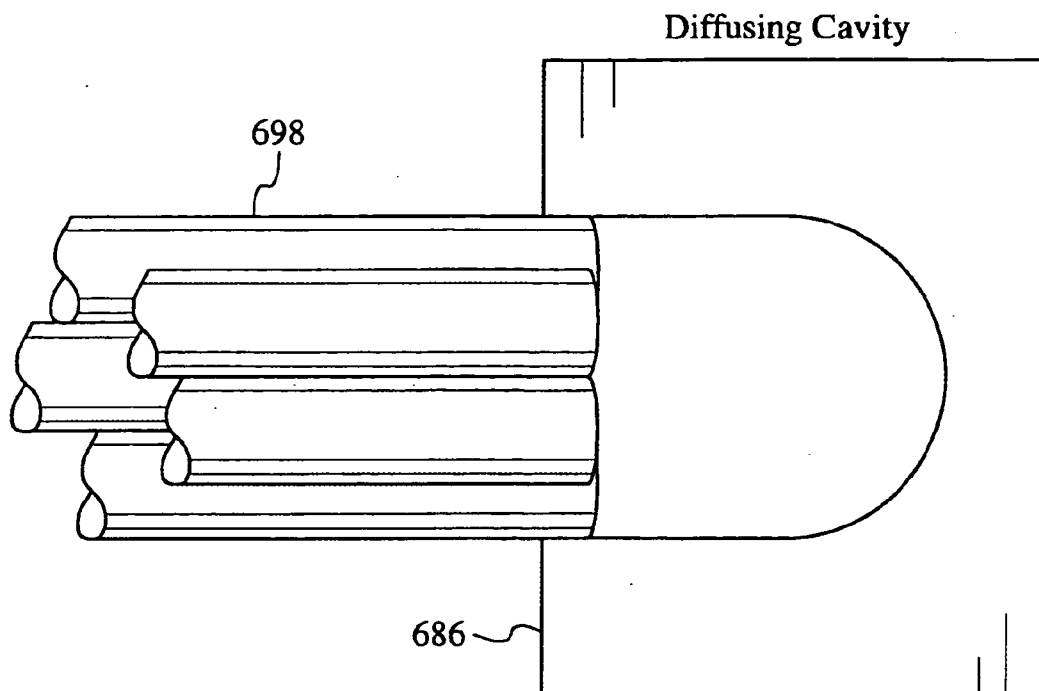

FIG. 35A

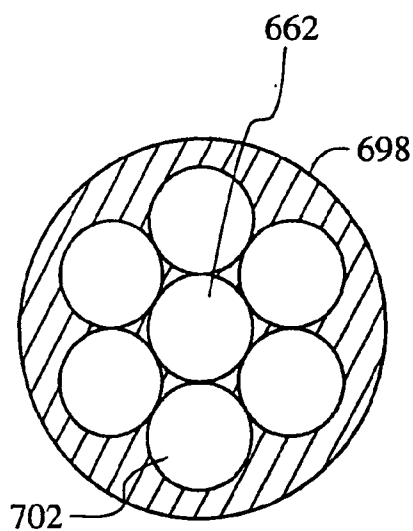

FIG. 35B

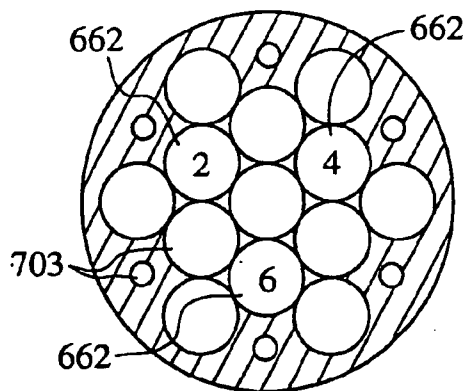

FIG. 35C

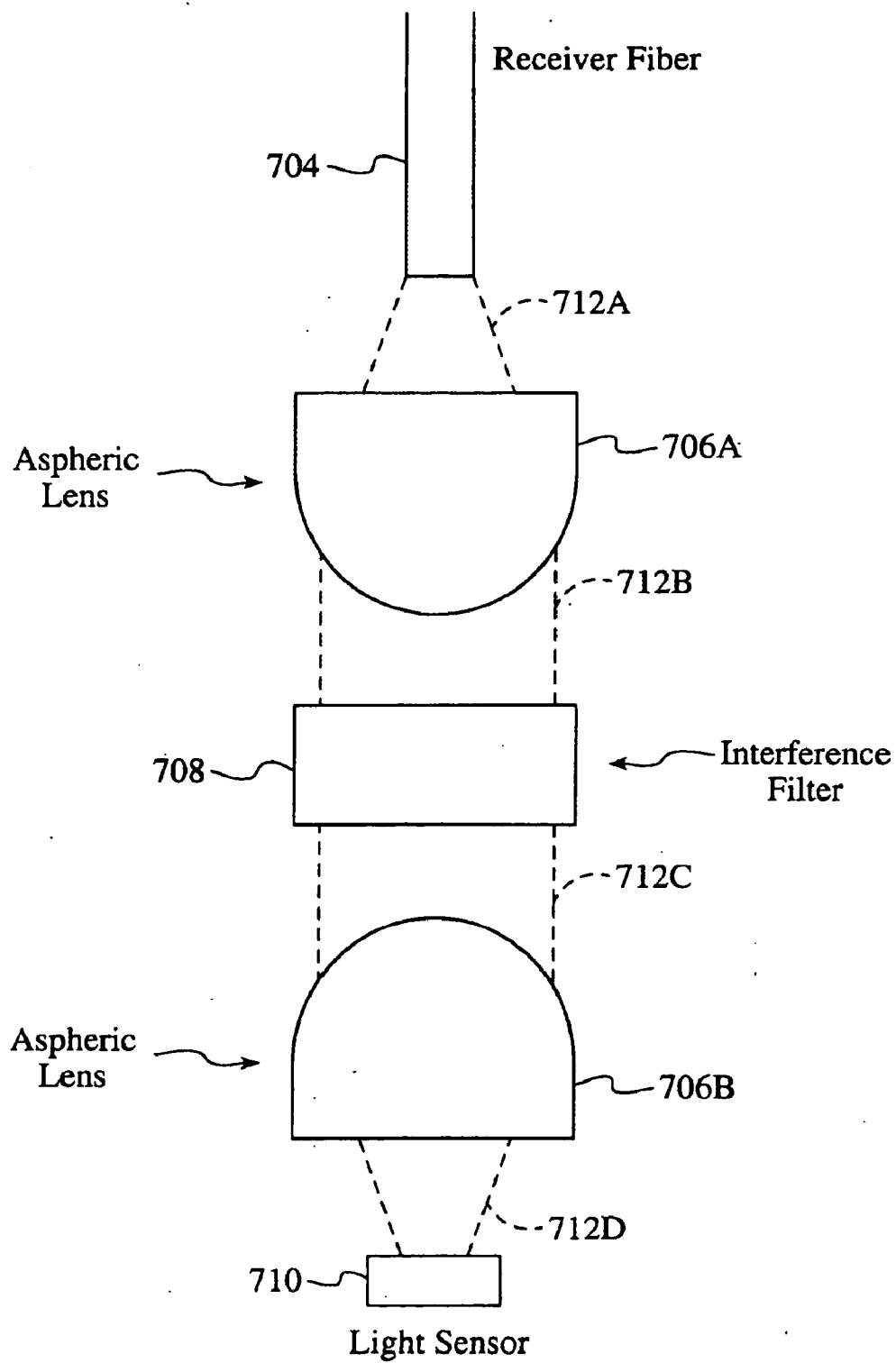

FIG. 36

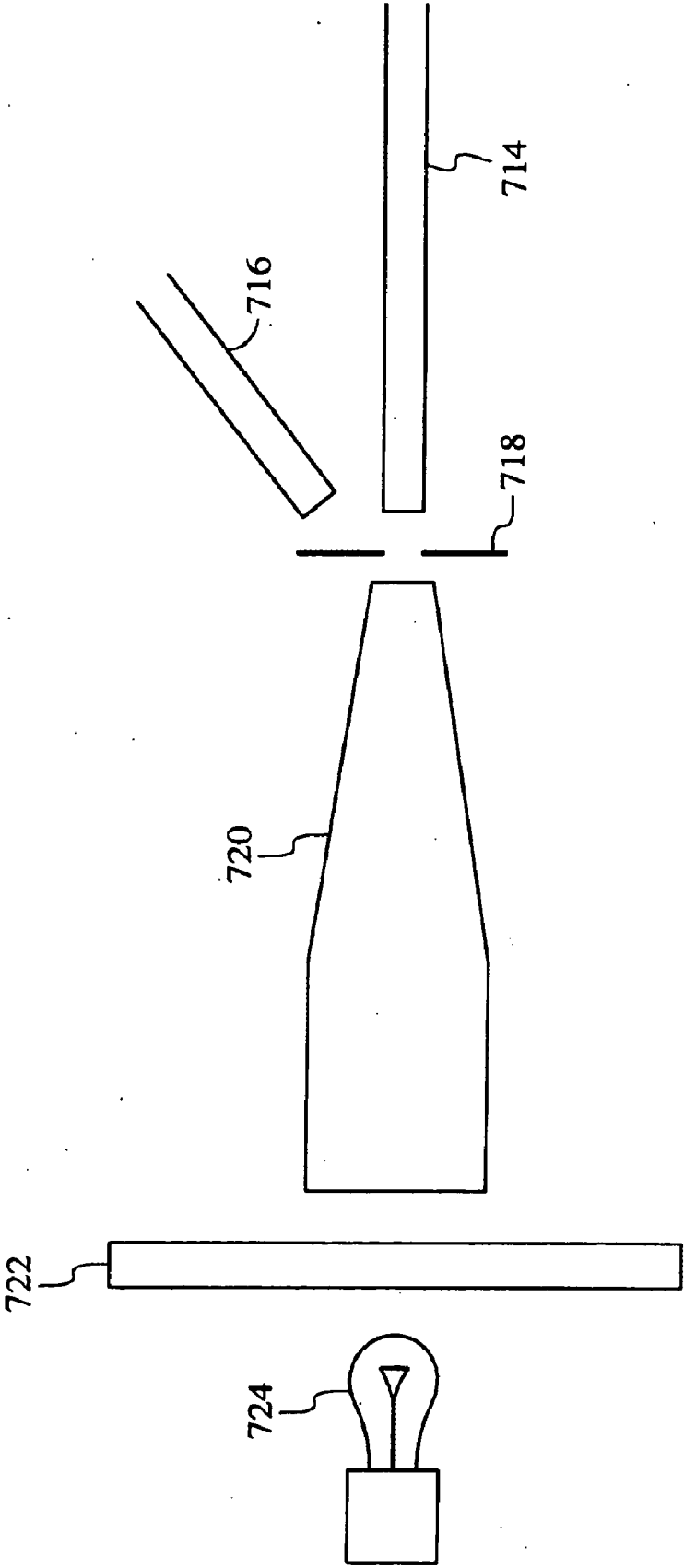
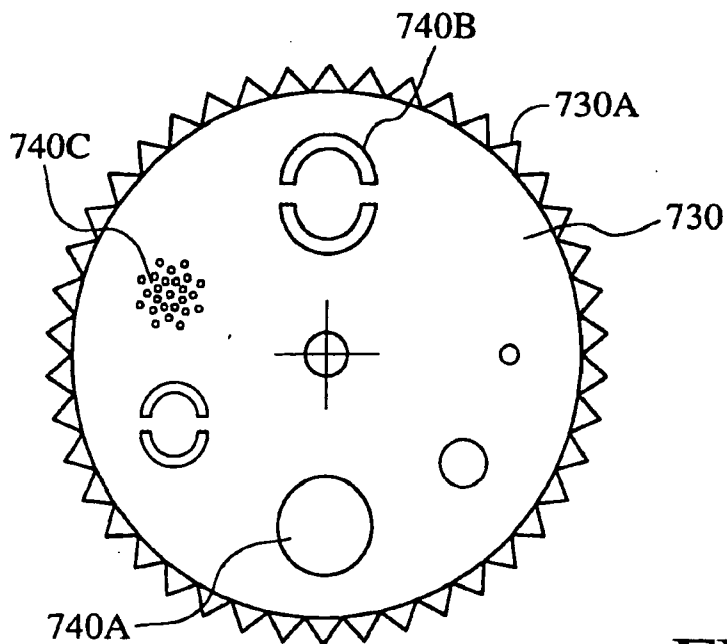
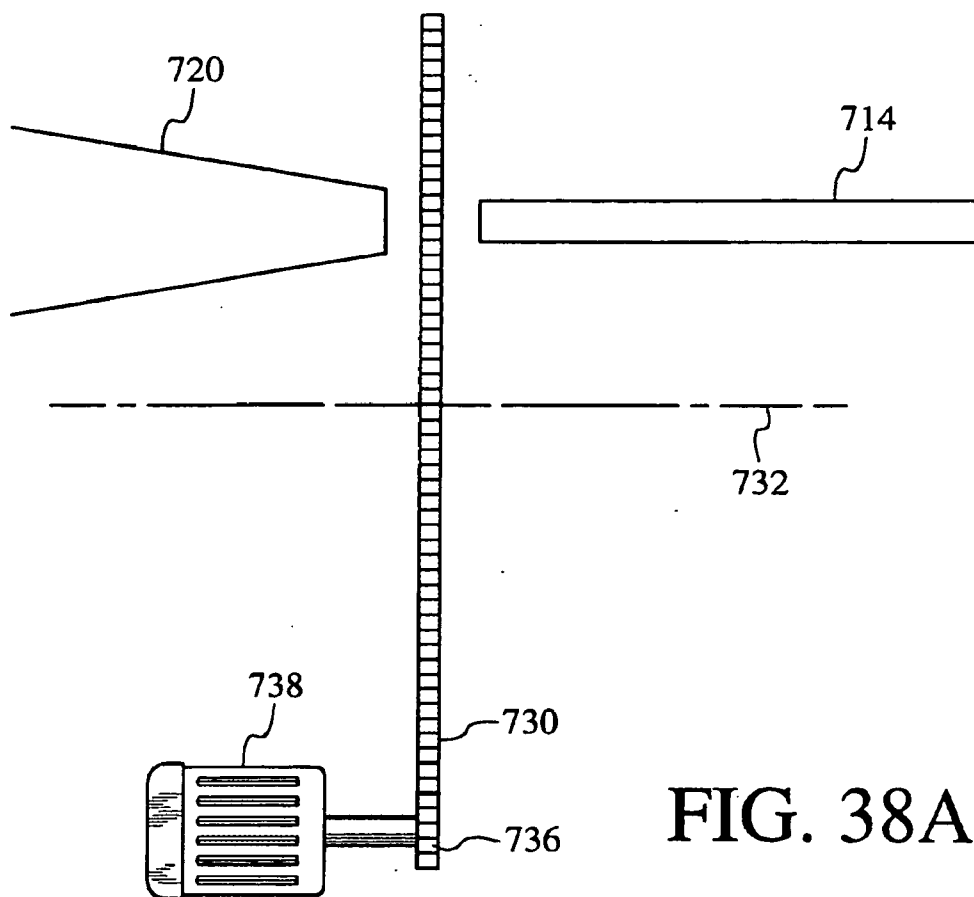

FIG. 37



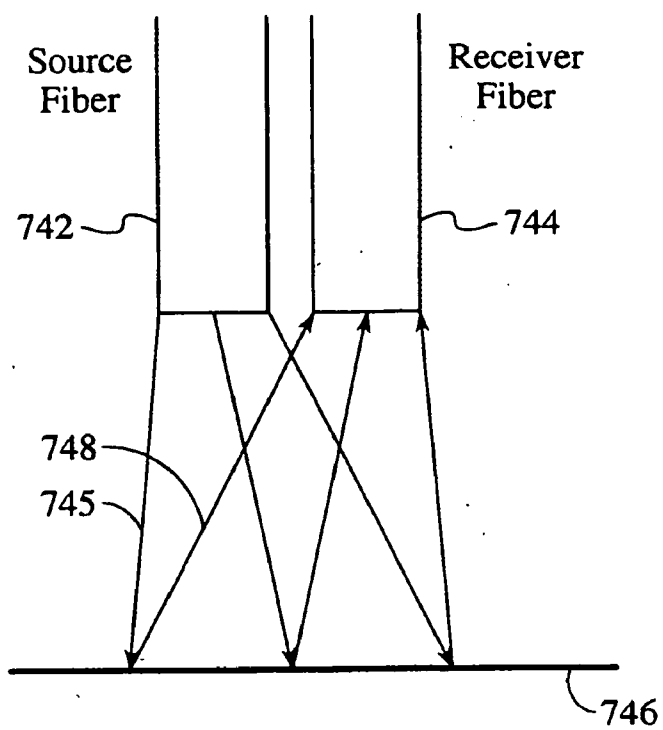

FIG. 39A

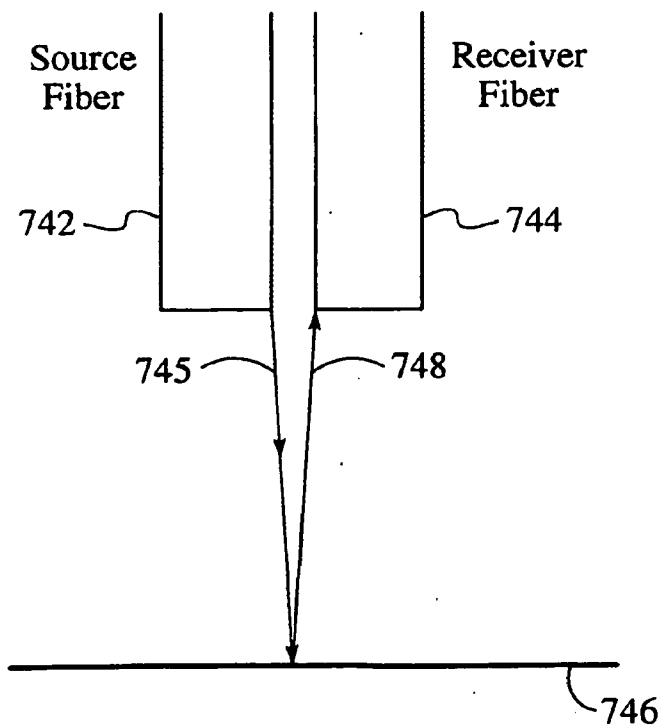

FIG. 39B

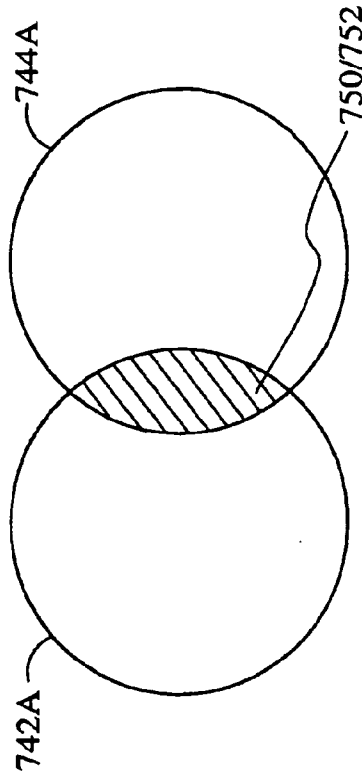
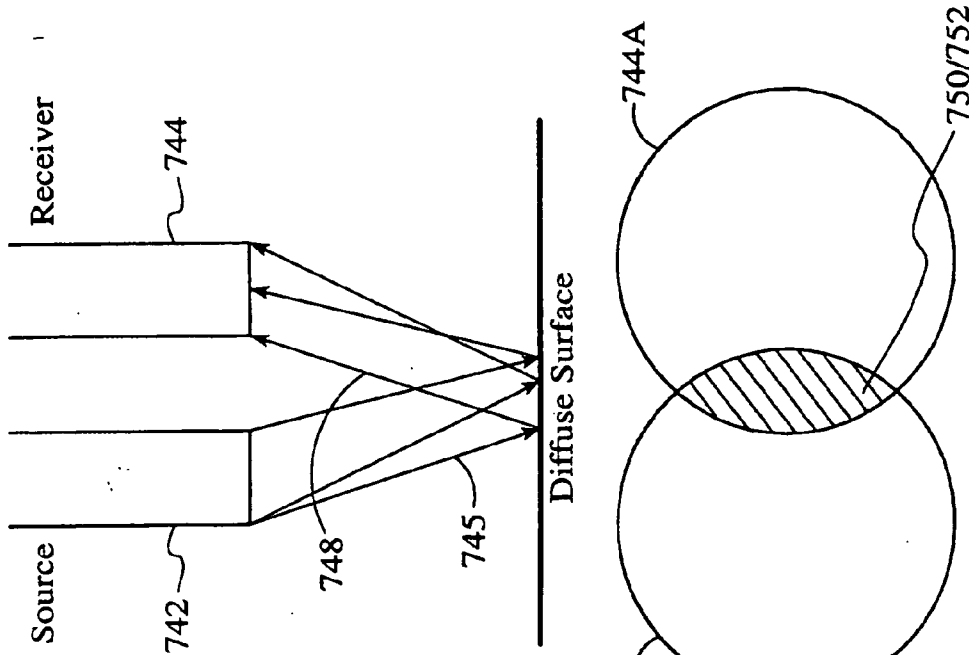

FIG. 40B

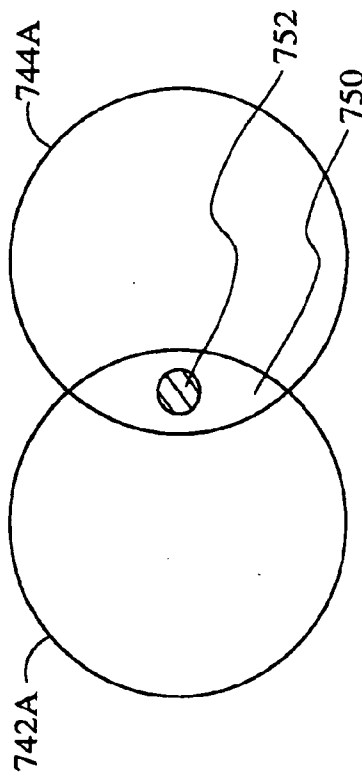
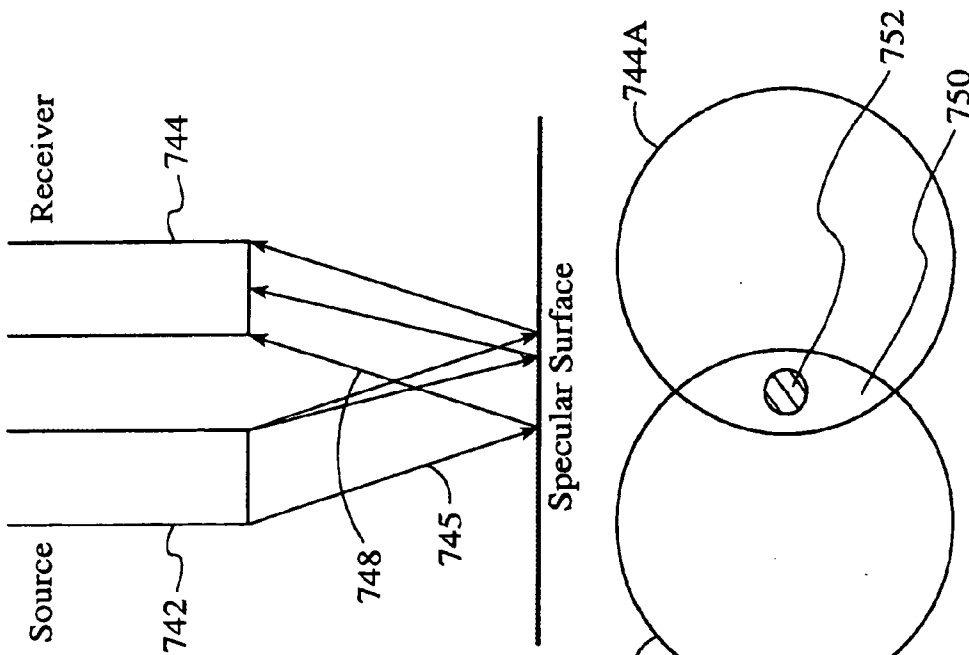

FIG. 40A

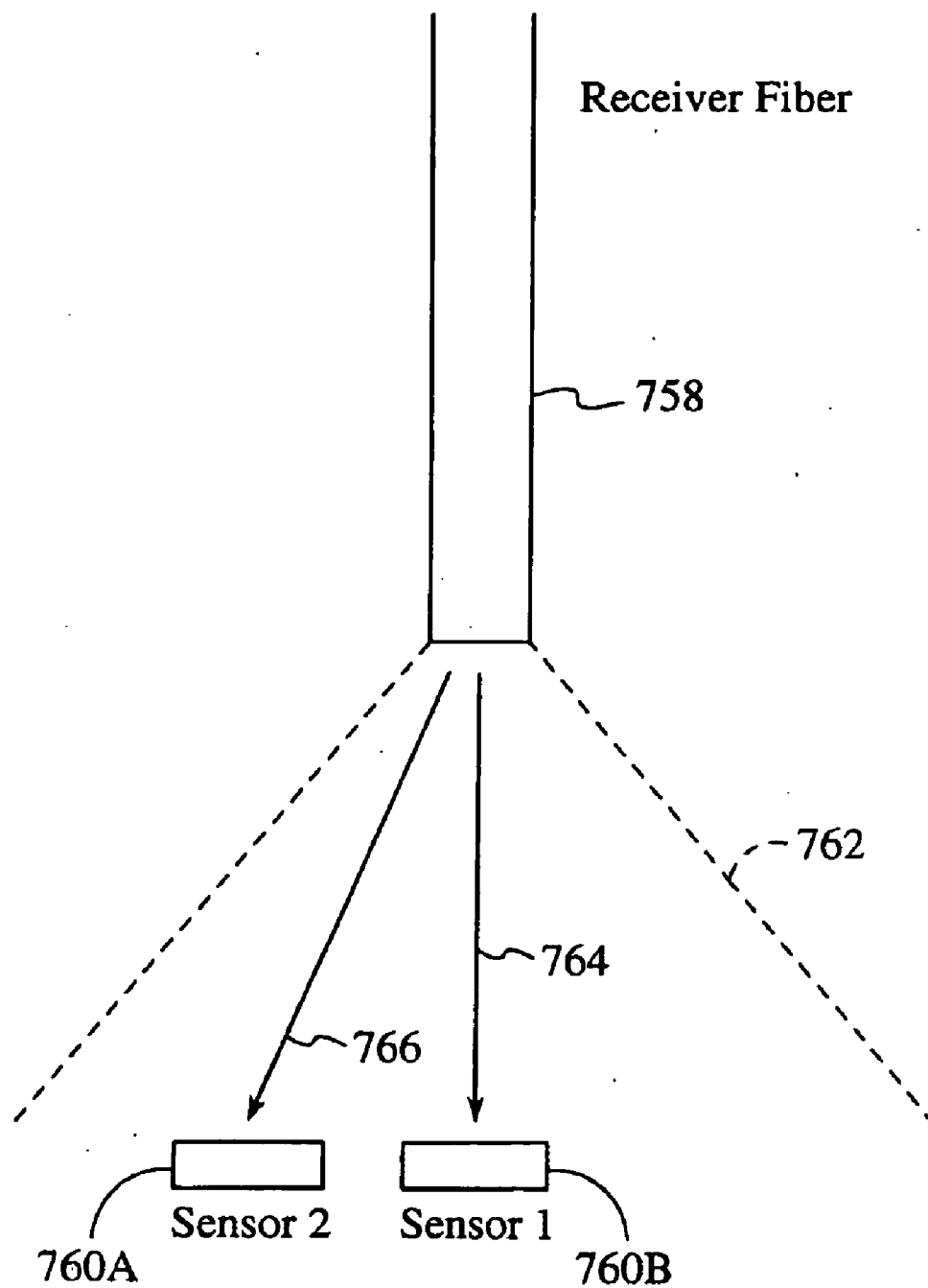

FIG. 41

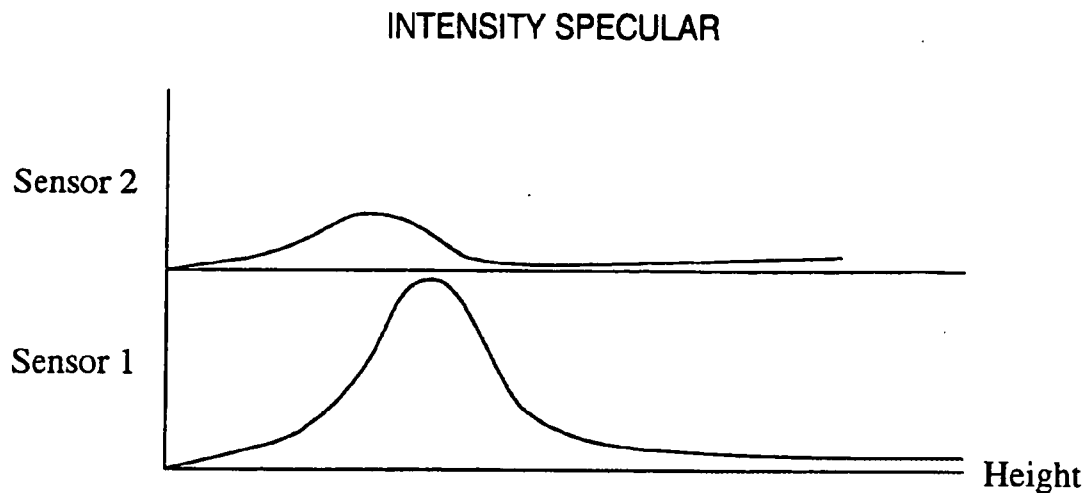

FIG. 42A

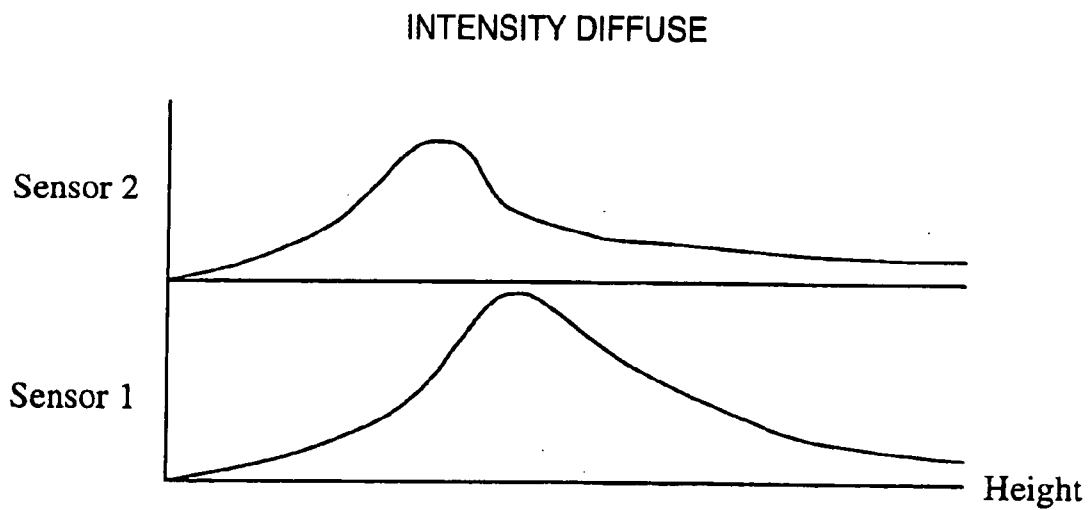

FIG. 42B

APPARATUS AND METHOD FOR MEASURING OPTICAL CHARACTERISTICS OF AN OBJECT

[0001] This application is a continuation of application Ser. No. 11/118,903, filed Apr. 29, 2005, now U.S. Pat. No. 7,119,892, which is a continuation of application Ser. No. 10/302,215, filed Nov. 22, 2002, now U.S. Pat. No. 6,888,634, which is a continuation of application Ser. No. 09/462,020, filed Dec. 29, 1999, now U.S. Pat. No. 6,501,542, which is the National Stage of International Application No. PCT/US98/13764.

FIELD OF THE INVENTION

[0002] The present invention relates to devices and methods for measuring optical characteristics such as color spectrums, translucence, gloss, and other characteristics of objects, and more particularly to devices and methods for measuring the color and other optical characteristics of teeth, fabric or other objects or surfaces with a hand-held probe that presents minimal problems with height or angular dependencies.

BACKGROUND OF THE INVENTION

[0003] Various color/optical measuring devices such as spectrophotometers and calorimeters are known in the art. To understand the limitations of such conventional devices, it is helpful to understand certain principles relating to color. Without being bound by theory, Applicants provide the following discussion.

[0004] The color of an object determines the manner in which light is reflected from the object. When light is incident upon an object, the reflected light will vary in intensity and wavelength dependent upon the color of the object. Thus, a red object will reflect red light with a greater intensity than a blue or a green object, and correspondingly a green object will reflect green light with a greater intensity than a red or blue object.

[0005] The optical properties of an object are also affected by the manner in which light is reflected from the surface. Glossy objects, those that reflect light specularly such as mirrors or other highly polished surfaces, reflect light differently than diffuse objects or those that reflect light in all directions, such as the reflection from a rough or otherwise non-polished surface. Although both objects may have the same color and exhibit the same reflectance or absorption optical spectral responses, their appearances differ because of the manner in which they reflect light.

[0006] Additionally, many objects may be translucent or have semi-translucent surfaces or thin layers covering their surfaces. For example, some materials have a complicated structure consisting of an outer layer and an inner layer. The outer layer is semitranslucent. The inner layers are also translucent to a greater or lesser degree. Such materials and objects also appear different from objects that are opaque, even though they may be the same color because of the manner in which they can propagate light in the translucent layer and emit the light ray displaced from its point of entry.

[0007] One method of quantifying the color of an object is to illuminate it with broad band spectrum or "white" light, and measure the spectral properties of the reflected light over the entire visible spectrum and compare the reflected spectrum with the incident light spectrum. Such instruments

typically require a broad band spectrophotometer, which generally are expensive, bulky and relatively cumbersome to operate, thereby limiting the practical application of such instruments.

[0008] For certain applications, the broad band data provided by a spectrophotometer is unnecessary. For such applications, devices have been produced or proposed that quantify color in terms of a numerical value or relatively small set of values representative of the color of the object.

[0009] It is known that the color of an object can be represented by three values. For example, the color of an object can be represented by red, green and blue values, an intensity value and color difference values, by a CIE value, or by what are known as "tristimulus values" or numerous other orthogonal combinations. For most tristimulus systems, the three values are orthogonal; i.e., any combination of two elements in the set cannot be included in the third element.

[0010] One such method of quantifying the color of an object is to illuminate an object with broad band "white" light and measure the intensity of the reflected light after it has been passed through narrow band filters. Typically three filters (such as red, green and blue) are used to provide tristimulus light values representative of the color of the surface. Yet another method is to illuminate an object with three monochromatic light sources or narrow band light sources (such as red, green and blue) one at a time and then measure the intensity of the reflected light with a single light sensor. The three measurements are then converted to a tristimulus value representative of the color of the surface. Such color measurement techniques can be utilized to produce equivalent tristimulus values representative of the color of the surface. Generally, it does not matter if a "white" light source is used with a plurality of color sensors (or a continuum in the case of a spectrophotometer), or if a plurality of colored light sources are utilized with a single light sensor.

[0011] There are, however, difficulties with the conventional techniques. When light is incident upon a surface and reflected to a light receiver, the height of the light sensor and the angle of the sensor relative to the surface and to the light source also affect the intensity of the received light. Since the color determination is being made by measuring and quantifying the intensity of the received light for different colors, it is important that the height and angular dependency of the light receiver be eliminated or accounted for in some manner.

[0012] One method for eliminating the height and angular dependency of the light source and receiver is to provide a fixed mounting arrangement where the light source and receiver are stationary and the object is always positioned and measured at a preset height and angle. The fixed mounting arrangement greatly limits the applicability of such a method. Another method is to add mounting feet to the light source and receiver probe and to touch the object with the probe to maintain a constant height and angle. The feet in such an apparatus must be wide enough apart to insure that a constant angle (usually perpendicular) is maintained relative to the object. Such an apparatus tends to be very difficult to utilize on small objects or on objects that are hard to reach, and in general does not work satisfactorily in measuring objects with curved surfaces.

[0013] The use of color measuring devices in the field of dentistry has been proposed. In modern dentistry, the color of teeth typically are quantified by manually comparing a patient's teeth with a set of "shade guides." There are numerous shade guides available for dentists in order to properly select the desired color of dental prosthesis. Such shade guides have been utilized for decades and the color determination is made subjectively by the dentist by holding a set of shade guides next to a patient's teeth and attempting to find the best match. Unfortunately, however, the best match often is affected by the ambient light color in the dental operatory and the surrounding color of the patient's makeup or clothing and by the fatigue level of the dentist.

[0014] Similar subjective color quantification also is made in the paint industry by comparing the color of an object with a paint reference guide. There are numerous paint guides available in the industry and the color determination also often is affected by ambient light color, user fatigue and the color sensitivity of the user. Many individuals are color insensitive (color blind) to certain colors, further complicating color determination.

[0015] In general, color quantification is needed in many industries. Several, but certainly not all, applications include: dentistry (color of teeth); dermatology (color of skin lesions); interior decorating (color of paint, fabrics); the textile industry; automotive repair (matching paint colors); photography (color of reproductions, color reference of photographs to the object being photographed); printing and lithography; cosmetics (hair and skin color, makeup matching); and other applications in which it useful to measure color in an expedient and reliable manner.

[0016] With respect to such applications, however, the limitations of conventional color/optical measuring techniques typically restrict the utility of such techniques. For example, the high cost and bulkiness of typical broad band spectrometers, and the fixed mounting arrangements or feet required to address the height and angular dependency, often limit the applicability of such conventional techniques.

[0017] Moreover, another limitation of such conventional methods and devices are that the resolution of the height and angular dependency problems typically require contact with the object being measured. In certain applications, it may be desirable to measure and quantify the color of an object with a small probe that does not require contact with the surface of the object. In certain applications, for example, hygienic considerations make such contact undesirable. In the other applications such as interior decorating, contact with the object can mar the surface (such as if the object is coated with wet paint) or otherwise cause undesirable effects.

[0018] In summary, there is a need for a low cost, handheld probe of small size that can reliably measure and quantify the color and other optical characteristics of an object without requiring physical contact with the object, and also a need for methods based on such a device in the field of dentistry and other applications.

SUMMARY OF THE INVENTION

[0019] In accordance with the present invention, devices and methods are provided for measuring the color and other optical characteristics of objects, reliably and with minimal problems of height and angular dependence. A handheld

probe is utilized in the present invention, with the handheld probe containing a number of fiber optics in certain preferred embodiments. Light is directed from one (or more) light source(s) towards the object to be measured, which in certain preferred embodiments is a central light source fiber optic (other light sources and light source arrangements also may be utilized). Light reflected from the object is detected by a number of light receivers. Included in the light receivers (which may be light receiver fiber optics) are a plurality of perimeter and/or broadband or other receivers (which may be receiver fiber optics, etc.). In certain preferred embodiments, a number of groups of perimeter fiber optics are utilized in order to take measurements at a desired, and predetermined height and angle, thereby minimizing height and angular dependency problems found in conventional methods, and to quantify other optical characteristics such as gloss. In certain embodiments, the present invention also may measure gloss, translucence, and fluorescence characteristics of the object being measured, as well as surface texture and/or other optical or surface characteristics. In certain embodiments, the present invention may distinguish the surface spectral reflectance response and also a bulk spectral response.

[0020] The present invention may include constituent elements of a broad band spectrophotometer, or, alternatively, may include constituent elements of a tristimulus type colorimeter. The present invention may employ a variety of color measuring devices in order to measure color and other optical characteristics in a practical, reliable and efficient manner, and in certain preferred embodiments includes a color filter array and a plurality of color sensors. A microprocessor is included for control and calculation purposes. A temperature sensor is included to measure temperature in order to detect abnormal conditions and/or to compensate for temperature effects of the filters or other components of the system. In addition, the present invention may include audio feedback to guide the operator in making color/optical measurements, as well as one or more display devices for displaying control, status or other information.

[0021] With the present invention, color/optical measurements may be made with a handheld probe in a practical and reliable manner, essentially free of height and angular dependency problems, without resorting to fixtures, feet or other undesirable mechanical arrangements for fixing the height and angle of the probe with respect to the object.

[0022] Accordingly, it is an object of the present invention to address limitations of conventional color/optical measuring techniques.

[0023] It is another object of the present invention to provide a method and device useful in measuring the color or other optical characteristics of teeth, fabric or other objects or surfaces with a hand-held probe of practical size that may advantageously utilize, but does not necessarily require, contact with the object or surface.

[0024] It is a further object of the present invention to provide a color/optical measurement probe and method that does not require fixed position mechanical mounting, feet or other mechanical impediments.

[0025] It is yet another object of the present invention to provide a probe and method useful for measuring color and/or other optical characteristics that may be utilized with a probe simply placed near the surface to be measured.

[0026] It is a still further object of the present invention to provide a probe and method that are capable of determining translucency characteristics of the object being measured.

[0027] It is still further object of the present invention to provide a probe and method that are capable of determining translucency characteristics of the object being measured by making measurements from one side of the object.

[0028] It is a further object of the present invention to provide a probe and method that are capable of determining surface texture characteristics of the object being measured.

[0029] It is a still further object of the present invention to provide a probe and method that are capable of determining fluorescence characteristics of the object being measured.

[0030] It is yet a further object of the present invention to provide a probe and method that are capable of determining gloss (or degree of specular reflectance) characteristics of the object being measured.

[0031] It is another object of the present invention to provide a probe and method that can measure the area of a small spot singularly, or that also can measure irregular shapes by moving the probe over an area and integrating the color of the entire area.

[0032] It is a further object of the present invention to provide a method of measuring the color of an object and preparing prostheses, colored fillings, or other materials or taking other action.

[0033] It is yet another object of the present invention to provide a method and apparatus that minimizes contamination problems, while providing a reliable and expedient manner in which to measure an object and prepare coatings, layers, prostheses, colored fillings, or other materials.

[0034] It is an object of the present invention to provide methods of using measured data to implement processes for forming objects, prostheses and the like, as well as methods for keeping such measurement and/or other data as part of a record database.

[0035] It also is an object of the present invention to provide probes and methods for measuring optical characteristics with a probe that is held substantially stationary with respect to the object being measured.

[0036] Finally, it is an object of the present invention to provide probes and methods for measuring optical characteristics with a probe that may have a removable tip or shield that may be removed for cleaning, disposed after use or the like.

BRIEF DESCRIPTION OF THE DRAWINGS

[0037] The present invention may be more fully understood by a description of certain preferred embodiments in conjunction with the attached drawings in which:

[0038] FIG. 1 is a diagram illustrating a preferred embodiment of the present invention;

[0039] FIG. 2 is a diagram illustrating a cross section of a probe that may be used in accordance with a certain embodiment of the present invention;

[0040] FIG. 3 is a diagram illustrating an illustrative arrangement of fiber optic receivers and sensors utilized with a certain embodiment;

[0041] FIGS. 4A to 4C illustrate certain geometric considerations of fiber optics;

[0042] FIGS. 5A and 5B illustrate the light amplitude received by fiber optic light receivers as the receivers are moved towards and away from an object;

[0043] FIG. 6 is a flow chart illustrating a color measuring method in accordance with an embodiment of the present invention;

[0044] FIGS. 7A and 7B illustrate a protective cap that may be used with certain embodiments of the present invention;

[0045] FIGS. 8A and 8B illustrate removable probe tips that may be used with certain embodiments of the present invention;

[0046] FIG. 9 illustrates a fiber optic bundle in accordance with another embodiment, which may serve to further the understanding of preferred embodiments of the present invention;

[0047] FIGS. 10A, 10B, 10C, and 10D illustrate and describe other fiber optic bundle configurations and principles, which may serve to further the understanding of preferred embodiments of the present invention;

[0048] FIG. 11 illustrates a linear optical sensor array that may be used in certain embodiments of the present invention;

[0049] FIG. 12 illustrates a matrix optical sensor array that may be used in certain embodiments of the present invention;

[0050] FIGS. 13A and 13B illustrate certain optical properties of a filter array that may be used in certain embodiments of the present invention;

[0051] FIGS. 14A and 14B illustrate examples of received light intensities of receivers used in certain embodiments of the present invention;

[0052] FIG. 15 is a flow chart illustrating audio tones that may be used in certain embodiments of the present invention;

[0053] FIG. 16 illustrates an embodiment, which utilizes a plurality of rings of light receivers that may be utilized to take measurements with the probe held substantially stationary with respect to the object being measured, which may serve to further the understanding of preferred embodiments of the present invention;

[0054] FIGS. 17 and 18 illustrate an embodiment, which utilizes a mechanical movement and also may be utilized to take measurements with the probe held substantially stationary with respect to the object being measured, which may serve to further the understanding of preferred embodiments of the present invention;

[0055] FIGS. 19A to 19C illustrate embodiments of the present invention in which coherent light conduits may serve as removable probe tips;

[0056] FIGS. 20A and 20B illustrate cross sections of probes that may be used in accordance with preferred embodiments of the present invention;

[0057] FIGS. 21 and 22A and 22B illustrate certain geometric and other properties of fiber optics for purposes of understanding certain preferred embodiments;

[0058] FIGS. 23A and 23B illustrate probes for measuring "specular-excluded" type spectrums in accordance with the present invention;

[0059] FIGS. 24, 25, and 26 illustrate embodiments in which cameras and reflectometer type instruments in accordance with the present invention are integrated;

[0060] FIGS. 27 and 28 illustrate certain handheld embodiments of the present invention; and

[0061] FIG. 29 illustrates an object in cross section, illustrating how embodiments of the present invention may be used to assess subsurface characteristics of various types of objects; and

[0062] FIGS. 30 to 42 illustrate other embodiments (systems, sources, receivers, etc.), aspects and features within the scope of the present invention.

DETAILED DESCRIPTION OF THE PREFERRED EMBODIMENTS

[0063] The present invention will be described in greater detail with reference to certain preferred embodiments and certain other embodiments, which may serve to further the understanding of preferred embodiments of the present invention. As described elsewhere herein, various refinements and substitutions of the various embodiments are possible based on the principles and teachings herein.

[0064] With reference to FIG. 1, an exemplary preferred embodiment of a color/optical characteristic measuring system and method in accordance with the present invention will be described.

[0065] Probe tip 1 encloses a plurality of fiber optics, each of which may constitute one or more fiber optic fibers. In a preferred embodiment, the fiber optics contained within probe tip 1 includes a single light source fiber optic and a number of groups of light receiver fiber optics. The use of such fiber optics to measure the color or other optical characteristics of an object will be described later herein. Probe tip 1 is attached to probe body 2, on which is fixed switch 17. Switch 17 communicates with microprocessor 10 through wire 18 and provides, for example, a mechanism by which an operator may activate the device in order to make a color/optical measurement. Fiber optics within probe tip 1 terminate at the forward end thereof (i.e., the end away from probe body 2). The forward end of probe tip 1 is directed towards the surface of the object to be measured as described more fully below. The fiber optics within probe tip 1 optically extend through probe body 2 and through fiber optic cable 3 to light sensors 8, which are coupled to microprocessor 10.

[0066] It should be noted that microprocessor 10 includes conventional associated components, such as memory (programmable memory, such as PROM, EPROM or EEPROM; working memory such as DRAMs or SRAMs; and/or other types of memory such as non-volatile memory, such as FLASH), peripheral circuits, clocks and power supplies, although for clarity such components are not explicitly shown. Other types of computing devices (such as other

microprocessor systems, programmable logic arrays or the like) are used in other embodiments of the present invention.

[0067] In the embodiment of FIG. 1, the fiber optics from fiber optic cable 3 end at splicing connector 4. From splicing connector 4, each or some of the receiver fiber optics used in this embodiment is/are spliced into a number of smaller fiber optics (generally denoted as fibers 7), which in this embodiment are fibers of equal diameter, but which in other preferred embodiments may be of unequal diameter and/or numeric aperture (NA) (including, for example, larger or smaller "height/angle" or perimeter fibers, as more fully described herein). One of the fibers of each group of fibers may pass to light sensors 8 through a neutral density filter (as more fully described with reference to FIG. 3), and collectively such neutrally filtered fibers may be utilized for purposes of height/angle determination, translucency determination, and gloss determination (and also may be utilized to measure other surface characteristics, as more fully described herein). Remaining fibers of each group of fibers may pass to light sensors 8 through color filters and may be used to make color/optical measurements. In still other embodiments, splicing connector 4 is not used, and fiber bundles of, for example, five or more fibers each extend from light sensors 8 to the forward end of probe tip 1. In certain embodiments, unused fibers or other materials may be included as part of a bundle of fibers for purposes of, for example, easing the manufacturing process for the fiber bundle. What should be noted is that, for purposes of the present invention, a plurality of light receiver fiber optics or elements (such as fibers 7) are presented to light sensors 8, with the light from the light receiver fiber optics/elements representing light reflected from object 20. While the various embodiments described herein present tradeoffs and benefits that may not have been apparent prior to the present invention (and thus may be independently novel), what is important for the present discussion is that light from fiber optics/elements at the forward end of probe tip 1 is presented to sensors 8 for color/optical measurements and angle/height determination, etc. In particular, fiber optic configurations of certain preferred embodiments will be explained in more detail hereinafter.

[0068] Light source 11 in the preferred embodiment is a halogen light source (of, for example, 5-100 watts, with the particular wattage chosen for the particular application), which may be under the control of microprocessor 10. The light from light source 11 reflects from cold mirror 6 and into source fiber optic 5. Source fiber optic 5 passes through to the forward end of probe tip 1 and provides the light stimulus used for purposes of making the measurements described herein. Cold mirror 6 reflects visible light and passes infra-red light, and is used to reduce the amount of infra-red light produced by light source 11 before the light is introduced into source fiber optic 5. Such infra-red light reduction of the light from a halogen source such as light source 11 can help prevent saturation of the receiving light sensors, which can reduce overall system sensitivity. Fiber 15 receives light directly from light source 11 and passes through to light sensors 8 (which may be through a neutral density filter). Microprocessor 10 monitors the light output of light source 11 through fiber 15, and thus may monitor and, if necessary compensate for, drift of the output of light source 11. In certain embodiments, microprocessor 10 also may sound an alarm (such as through speaker 16) or

otherwise provide some indication if abnormal or other undesired performance of light source **11** is detected.

[0069] The data output from light sensors **8** pass to microprocessor **10**. Microprocessor processes the data from light sensors **8** to produce a measurement of color and/or other characteristics. Microprocessor **10** also is coupled to key pad switches **12**, which serve as an input device. Through key pad switches **12**, the operator may input control information or commands, or information relating to the object being measured or the like. In general, key pad switches **12**, or other suitable data input devices (such as push button, toggle, membrane or other switches or the like), serve as a mechanism to input desired information to microprocessor **10**.

[0070] Microprocessor **10** also communicates with UART **13**, which enables microprocessor **10** to be coupled to an external device such as computer **13A**. In such embodiments, data provided by microprocessor **10** may be processed as desired for the particular application, such as for averaging, format conversion or for various display or print options, etc. In the preferred embodiment, UART **13** is configured so as to provide what is known as a RS232 interface, such as is commonly found in personal computers.

[0071] Microprocessor **10** also communicates with LCD **14** for purposes of displaying status, control or other information as desired for the particular application. For example, color bars, charts or other graphic representations of the color or other collected data and/or the measured object may be displayed. In other embodiments, other display devices are used, such as CRTs, matrix-type LEDs, lights or other mechanisms for producing a visible indicia of system status or the like. Upon system initialization, for example, LCD **14** may provide an indication that the system is stable, ready and available for taking color measurements.

[0072] Also coupled to microprocessor **10** is speaker **16**. Speaker **16**, in a preferred embodiment as discussed more fully below, serves to provide audio feedback to the operator, which may serve to guide the operator in the use of the device. Speaker **16** also may serve to provide status or other information alerting the operator of the condition of the system, including an audio tone, beeps or other audible indication (i.e., voice) that the system is initialized and available for taking measurements. Speaker **16** also may present audio information indicative of the measured data, shade guide or reference values corresponding to the measured data, or an indication of the status of the color/optical measurements.

[0073] Microprocessor **10** also receives an input from temperature sensor **9**. Given that many types of filters (and perhaps light sources or other components) may operate reliably only in a given temperature range, temperature sensor **9** serves to provide temperature information to microprocessor **10**. In particular, color filters, such as may be included in light sensors **8**, may be sensitive to temperature, and may operate reliably only over a certain temperature range. In certain embodiments, if the temperature is within a usable range, microprocessor **10** may compensate for temperature variations of the color filters. In such embodiments, the color filters are characterized as to filtering characteristics as a function of temperature, either by data provided by the filter manufacturer, or through measurement as a function of temperature. Such filter temperature com-

pensation data may be stored in the form of a look-up table in memory, or may be stored as a set of polynomial coefficients from which the temperature characteristics of the filters may be computed by microprocessor **10**.

[0074] In general, under control of microprocessor **10**, which may be in response to operator activation (through, for example, key pad switches **12** or switch **17**), light is directed from light source **11**, and reflected from cold mirror **6** through source fiber optic **5** (and through fiber optic cable **3**, probe body **2** and probe tip **1**, or through some other suitable light source element) and is directed onto object **20**. Light reflected from object **20** passes through the receiver fiber optics/elements in probe tip **1** to light sensors **8** (through probe body **2**, fiber optic cable **3** and fibers **7**). Based on the information produced by light sensors **8**, microprocessor **10** produces a color/optical measurement result or other information to the operator. Color measurement or other data produced by microprocessor **10** may be displayed on display **14**, passed through UART **13** to computer **13A**, or used to generate audio information that is presented to speaker **16**. Other operational aspects of the preferred embodiment illustrated in FIG. **1** will be explained hereinafter.

[0075] With reference to FIG. **2**, an embodiment of a fiber optic arrangement presented at the forward end of probe tip **1** will now be described, which may serve to further the understanding of preferred embodiments of the present invention. As illustrated in FIG. **2**, this embodiment utilizes a single central light source fiber optic, denoted as light source fiber optic **S**, and a plurality of perimeter light receiver fiber optics, denoted as light receivers **R1**, **R2** and **R3**. As is illustrated, this embodiment utilizes three perimeter fiber optics, although in other embodiments two, four or some other number of receiver fiber optics are utilized. As more fully described herein, the perimeter light receiver fiber optics serve not only to provide reflected light for purposes of making the color/optical measurement, but such perimeter fibers also serve to provide information regarding the angle and height of probe tip **1** with respect to the surface of the object that is being measured, and also may provide information regarding the surface characteristics of the object that is being measured.

[0076] In the illustrated embodiment, receiver fiber optics **R1** to **R3** are positioned symmetrically around source fiber optic **S**, with a spacing of about 120 degrees from each other. It should be noted that spacing t is provided between receiver fiber optics **R1** to **R3** and source fiber optic **S**. While the precise angular placement of the receiver fiber optics around the perimeter of the fiber bundle in general is not critical, it has been determined that three receiver fiber optics positioned 120 degrees apart generally may give acceptable results. As discussed above, in certain embodiments light receiver fiber optics **R1** to **R3** each constitute a single fiber, which is divided at splicing connector **4** (refer again to FIG. **1**), or, in alternate embodiments, light receiver fiber optics **R1** to **R3** each constitute a bundle of fibers, numbering, for example, at least five fibers per bundle. It has been determined that, with available fibers of uniform size, a bundle of, for example, seven fibers may be readily produced (although as will be apparent to one of skill in the art, the precise number of fibers may be determined in view of the desired number of receiver fiber optics, manufacturing considerations, etc.). The use of light receiver fiber optics **R1**

to R3 to produce color/optical measurements is further described elsewhere herein, although it may be noted here that receiver fiber optics R1 to R3 may serve to detect whether, for example, the angle of probe tip 1 with respect to the surface of the object being measured is at 90 degrees, or if the surface of the object being measured contains surface texture and/or spectral irregularities. In the case where probe tip 1 is perpendicular to the surface of the object being measured and the surface of the object being measured is a diffuse reflector (i.e., a matte-type reflector, as compared to a glossy, spectral, or shiny-type reflector which may have "hot spots"), then the light intensity input into the perimeter fibers should be approximately equal. It also should be noted that spacing *t* serves to adjust the optimal height at which color/optical measurements should be made (as more fully described below). Preferred embodiments, as described hereinafter, may enable the quantification of the gloss or degree of spectral reflection of the object being measured.

[0077] In one particular aspect useful with embodiments of the present invention, area between the fiber optics on probe tip 1 may be wholly or partially filled with a non-reflective material and/or surface (which may be a black mat, contoured or other non-reflective surface). Having such exposed area of probe tip 1 non-reflective helps to reduce undesired reflections, thereby helping to increase the accuracy and reliability.

[0078] With reference to FIG. 3, a partial arrangement of light receiver fiber optics and sensors that may be used in a preferred embodiment of the present invention will now be described. Fibers 7 represent light receiving fiber optics, which transmit light reflected from the object being measured to light sensors 8. In an exemplary embodiment, sixteen sensors (two sets of eight) are utilized, although for ease of discussion only 8 are illustrated in FIG. 3 (in this preferred embodiment, the circuitry of FIG. 3 is duplicated, for example, in order to result in sixteen sensors). In other embodiments, other numbers of sensors are utilized in accordance with the present invention.

[0079] Light from fibers 7 is presented to sensors 8, which in a preferred embodiment pass through filters 22 to sensing elements 24. In this preferred embodiment, sensing elements 24 include light-to-frequency converters, manufactured by Texas Instruments and sold under the part number TSL230. Such converters constitute, in general, photo diode arrays that integrate the light received from fibers 7 and output an AC signal with a frequency proportional to the intensity (not frequency) of the incident light. Without being bound by theory, the basic principle of such devices is that, as the intensity increases, the integrator output voltage rises more quickly, and the shorter the integrator rise time, the greater the output frequency. The outputs of the TSL230 sensors are TTL compatible digital signals, which may be coupled to various digital logic devices.

[0080] The outputs of sensing elements 24 are, in this embodiment, asynchronous signals of frequencies depending upon the light intensity presented to the particular sensing elements, which are presented to processor 26. In a preferred embodiment, processor 26 is a Microchip PIC16C55 or PIC16C57 microprocessor, which as described more fully herein implements an algorithm to measure the frequencies of the signals output by sensing elements 24. In

other embodiments, a more integrated microprocessor/microcontroller, such as Hitachi's SH RISC microcontrollers, is utilized to provide further system integration or the like.

[0081] As previously described, processor 26 measures the frequencies of the signals output from sensing elements 24. In a preferred embodiment, processor 26 implements a software timing loop, and at periodic intervals processor 26 reads the states of the outputs of sensing elements 24. An internal counter is incremented each pass through the software timing loop. The accuracy of the timing loop generally is determined by the crystal oscillator time base (not shown in FIG. 3) coupled to processor 26 (such oscillators typically are quite stable). After reading the outputs of sensing elements 24, processor 26 performs an exclusive OR ("XOR") operation with the last data read (in a preferred embodiment such data is read in byte length). If any bit has changed, the XOR operation will produce a 1, and, if no bits have changed, the XOR operation will produce a 0. If the result is non-zero, the input byte is saved along with the value of the internal counter (that is incremented each pass through the software timing loop). If the result is zero, the system waits (e.g., executes no operation instructions) the same amount of time as if the data had to be saved, and the looping operation continues. The process continues until all eight inputs have changed at least twice, which enables measurement of a full 1/2 period of each input. Upon conclusion of the looping process, processor 26 analyzes the stored input bytes and internal counter states. There should be 2 to 16 saved inputs (for the 8 total sensors of FIG. 3) and counter states (if two or more inputs change at the same time, they are saved simultaneously). As will be understood by one of skill in the art, the stored values of the internal counter contains information determinative of the period of the signals received from sensing elements 24. By proper subtraction of internal counter values at times when an input bit has changed, the period may be calculated. Such periods calculated for each of the outputs of sensing elements is provided by processor 26 to microprocessor 10 (see, e.g., FIG. 1). From such calculated periods, a measure of the received light intensities may be calculated. In alternate embodiments, the frequency of the outputs of the TSL230 sensors is measured directly by a similar software loop as the one described above. The outputs are monitored by the RISC processor in a software timing loop and are XORed with the previous input as described above. If a transition occurs for a particular TSL230 input, a counter register for the particular TSL230 input is incremented. The software loop is executed for a pre-determined period of time and the frequency of the input is calculated by dividing the number of transitions by the pre-determined time and scaling the result. It will also be apparent to one skilled in the art that more sophisticated measurement schemes can also be implemented whereby both the frequency and period are simultaneously measured by high speed RISC processors such as those of the Hitachi SH family.

[0082] It should be noted that the sensing circuitry and methodology illustrated in FIG. 3 have been determined to provide a practical and expedient manner in which to measure the light intensities received by sensing elements 24. In other embodiments, other circuits and methodologies are employed (such other exemplary sensing schemes are described elsewhere herein).

[0083] As discussed above with reference to FIG. 1, one or more of fibers 7 measures light source 11, which may be through a neutral density filter, which serves to reduce the intensity of the received light in order to maintain the intensity roughly in the range of the other received light intensities. A number of fibers 7 also are from perimeter receiver fiber optics R1 to R3 (see, e.g., FIG. 2) and also may pass through neutral density filters. Such receiving fibers 7 serve to provide data from which angle/height information and/or surface characteristics may be determined.

[0084] The remaining twelve fibers (of the illustrated embodiment's total of 16 fibers) of fibers 7 pass through color filters and are used to produce the color measurement. In an embodiment, the color filters are Kodak Sharp Cutting Wratten Gelatin Filters, which pass light with wavelengths greater than the cut-off value of the filter (i.e., redish values), and absorb light with wavelengths less than the cut-off value of the filter (i.e., bluish values). "Sharp Cutting" filters are available in a wide variety of cut-off frequencies/wavelengths, and the cut-off values generally may be selected by proper selection of the desired cut-off filter. In an embodiment, the filter cut-off values are chosen to cover the entire visible spectrum and, in general, to have band spacings of approximately the visible band range (or other desired range) divided by the number of receivers/filters. As an example, 700 nanometers minus 400 nanometers, divided by 11 bands (produced by twelve color receivers/sensors), is roughly 30 nanometer band spacing.

[0085] With an array of cut-off filters as described above, and without being bound by theory or the specific embodiments described herein, the received optical spectrum may be measured/calculated by subtracting the light intensities of "adjacent" color receivers. For example, band 1 (400 nm to 430 nm)=(intensity of receiver 12) minus (intensity of receiver 11), and so on for the remaining bands. Such an array of cut-off filters, and the intensity values that may result from filtering with such an array, are more fully described in connection with FIGS. 13A to 14B.

[0086] It should be noted here that in alternate embodiments other color filter arrangements are utilized. For example, "notch" or bandpass filters may be utilized, such as may be developed using Schott glass-type filters (whether constructed from separate longpass/shortpass filters or otherwise) or notch interference filters such as those manufactured by Corion, etc.

[0087] In a preferred embodiment of the present invention, the specific characteristics of the light source, filters, sensors and fiber optics, etc., are normalized/calibrated by directing the probe towards, and measuring, a known color standard. Such normalization/calibration may be performed by placing the probe in a suitable fixture, with the probe directed from a predetermined position (i.e., height and angle) from the known color standard. Such measured normalization/calibration data may be stored, for example, in a look-up table, and used by microprocessor 10 to normalize or correct measured color or other data. Such procedures may be conducted at start-up, at regular periodic intervals, or by operator command, etc. In particular embodiments, a large number of measurements may be taken on materials of particular characteristics and processed and/or statistically analyzed or the like, with data representing or derived from such measurements stored in memory (such as a look-up

table or polynomial or other coefficients, etc.). Thereafter, based upon measurements of an object taken in accordance with the present invention, comparisons may be made with the stored data and assessments of the measured object made or predicted. In one illustrative example, an assessment or prediction may be made of whether the object is wet or dry (having water or other liquid on its surface, wet paint, etc.) based on measurements in accordance with the present invention. In yet another illustrative example, an assessment or prediction of the characteristics of an underlying material, such as tissue before the surface of a tooth, skin, or other material. Such capabilities may be further enhanced by comparisons with measurements taken of the object at an earlier time, such as data taken of the object at one or more earlier points in time. Such comparisons based on such historical data and/or stored data may allow highly useful assessments or predictions of the current or projected condition or status of the tooth, tissue, or other object, etc. Many other industrial uses of such surface and subsurface assessment/prediction capabilities are possible.

[0088] What should be noted from the above description is that the receiving and sensing fiber optics and circuitry illustrated in FIG. 3 provide a practical and expedient way to determine the color and other optical or other characteristics by measuring the intensity of the light reflected from the surface of the object being measured.

[0089] It also should be noted that such a system measures the spectral band of the reflected light from the object, and once measured such spectral data may be utilized in a variety of ways. For example, such spectral data may be displayed directly as intensity-wavelength band values. In addition, tristimulus type values may be readily computed (through, for example, conventional matrix math), as may any other desired color values. In one particular embodiment useful in dental applications (such as for dental prostheses), the color data is output in the form of a closest match or matches of dental shade guide value(s). In a preferred embodiment, various existing shade guides (such as the shade guides produced by Vita Zahnfabrik) are characterized and stored in a look-up table, or in the graphics art industry Pantone color references, and the color measurement data are used to select the closest shade guide value or values, which may be accompanied by a confidence level or other suitable factor indicating the degree of closeness of the match or matches, including, for example, what are known as ΔE values or ranges of ΔE values, or criteria based on standard deviations, such as standard deviation minimization. In still other embodiments, the color measurement data are used (such as with look-up tables) to select materials for the composition of paint or ceramics such as for prosthetic teeth. There are many other uses of such spectral data measured in accordance with the present invention.

[0090] It is known that certain objects such as human teeth may fluoresce, and such optical characteristics also may be measured in accordance with the present invention. A light source with an ultraviolet component may be used to produce more accurate color/optical data with respect to such objects. Such data may be utilized to adjust the amounts and or proportions or types of fluorescing materials in layers, coatings, restorations or prosthesis, etc. In certain embodiments, a tungsten/halogen source (such as used in a preferred embodiment) may be combined with a UV light source (such as a mercury vapor, xenon or other fluorescent

light source, etc.) to produce a light output capable of causing the object to fluoresce. Alternately, a separate UV light source, combined with a visible-light-blocking filter, may be used to illuminate the object. Such a UV light source may be combined with light from a red LED (for example) in order to provide a visual indication of when the UV light is on and also to serve as an aid for the directional positioning of the probe operating with such a light source. A second measurement may be taken using the UV light source in a manner analogous to that described earlier, with the band of the red LED or other supplemental light source being ignored. The second measurement may thus be used to produce an indication of the fluorescence of the object being measured. With such a UV light source, a silica fiber optic (or other suitable material) typically would be required to transmit the light to the object (standard fiber optic materials such as glass and plastic in general do not propagate UV light in a desired manner, etc.).

[0091] As described earlier, in certain preferred embodiments the present invention utilizes a plurality of perimeter receiver fiber optics spaced apart from and around a central source fiber optic to measure color and determine information regarding the height and angle of the probe with respect to the surface of the object being measured, which may include other surface characteristic information, etc. Without being bound by theory, certain principles underlying certain aspects of the present invention will now be described with reference to FIGS. 4A to 4C.

[0092] FIG. 4A illustrates a typical step index fiber optic consisting of a core and a cladding. For this discussion, it is assumed that the core has an index of refraction of n_0 and the cladding has an index of refraction of n_1 . Although the following discussion is directed to "step index" fibers, it will be appreciated by those of skill in the art that such discussion generally is applicable for gradient index fibers as well.

[0093] In order to propagate light without loss, the light must be incident within the core of the fiber optic at an angle greater than the critical angle, which may be represented as $\text{Sin}^{-1}\{n_1/n_0\}$, where n_0 is the index of refraction of the core and n_1 is the index of refraction of the cladding. Thus, all light must enter the fiber at an acceptance angle equal to or less than ϕ , with $\phi = 2 \times \text{Sin}^{-1}\{\sqrt{(n_0^2 - n_1^2)}\}$, or it will not be propagated in a desired manner.

[0094] For light entering a fiber optic, it must enter within the acceptance angle ϕ . Similarly, when the light exits a fiber optic, it will exit the fiber optic within a cone of angle ϕ as illustrated in FIG. 4A. The value $\sqrt{(n_0^2 - n_1^2)}$ is referred to as the aperture of the fiber optic. For example, a typical fiber optic may have an aperture of 0.5, and an acceptance angle of 60° .

[0095] Consider using a fiber optic as a light source. One end is illuminated by a light source (such as light source 11 of FIG. 1), and the other is held near a surface. The fiber optic will emit a cone of light as illustrated in FIG. 4A. If the fiber optic is held perpendicular to a surface it will create a circular light pattern on the surface. As the fiber optic is raised, the radius r of the circle will increase. As the fiber optic is lowered, the radius of the light pattern will decrease. Thus, the intensity of the light (light energy per unit area) in the illuminated circular area will increase as the fiber optic is lowered and will decrease as the fiber optic is raised.

[0096] The same principle generally is true for a fiber optic being utilized as a receiver. Consider mounting a light

sensor on one end of a fiber optic and holding the other end near an illuminated surface. The fiber optic can only propagate light without loss when the light entering the fiber optic is incident on the end of the fiber optic near the surface if the light enters the fiber optic within its acceptance angle ϕ . A fiber optic utilized as a light receiver near a surface will only accept and propagate light from the circular area of radius r on the surface. As the fiber optic is raised from the surface, the area increases. As the fiber optic is lowered to the surface, the area decreases.

[0097] Consider two fiber optics parallel to each other as illustrated in FIG. 4B. For simplicity of discussion, the two fiber optics illustrated are identical in size and aperture. The following discussion, however, generally would be applicable for fiber optics that differ in size and aperture. One fiber optic is a source fiber optic, the other fiber optic is a receiver fiber optic. As the two fiber optics are held perpendicular to a surface, the source fiber optic emits a cone of light that illuminates a circular area of radius r . The receiver fiber optic can only accept light that is within its acceptance angle ϕ , or only light that is received within a cone of angle ϕ . If the only light available is that emitted by the source fiber optic, then the only light that can be accepted by the receiver fiber optic is the light that strikes the surface at the intersection of the two circles as illustrated in FIG. 4C. As the two fiber optics are lifted from the surface, the proportion of the intersection of the two circular areas relative to the circular area of the source fiber optic increases. As they near the surface, the proportion of the intersection of the two circular areas to the circular area of the source fiber optic decreases. If the fiber optics are held too close to the surface (i.e., at or below a "critical height" h_c), the circular areas will no longer intersect and no light emitted from the source fiber optic will be received by the receiver fiber optic.

[0098] As discussed earlier, the intensity of the light in the circular area illuminated by the source fiber increases as the fiber is lowered to the surface. The intersection of the two cones, however, decreases as the fiber optic pair is lowered. Thus, as the fiber optic pair is lowered to a surface, the total intensity of light received by the receiver fiber optic increases to a maximal value, and then decreases sharply as the fiber optic pair is lowered still further to the surface. Eventually, the intensity will decrease essentially to zero at or below the critical height h_c (assuming the object being measured is not translucent, as described more fully herein), and will remain essentially zero until the fiber optic pair is in contact with the surface. Thus, as a source-receiver pair of fiber optics as described above are positioned near a surface and as their height is varied, the intensity of light received by the receiver fiber optic reaches a maximal value at a "peaking height" h_p .

[0099] Again without being bound by theory, an interesting property of the peaking height h_p has been observed. The peaking height h_p is a function primarily of the geometry of fixed parameters, such as fiber apertures, fiber diameters and fiber spacing. Since the receiver fiber optic in the illustrated arrangement is only detecting a maximum value and not attempting to quantify the value, its maximum in general is independent of the surface color. It is only necessary that the surface reflect sufficient light from the intersecting area of the source and receiver fiber optics to be within the detection range of the receiver fiber optic light sensor. Thus, in general

red or green or blue or any color surface will all exhibit a maximum at the same peaking height h_p .

[0100] Although the above discussion has focused on two fiber optics perpendicular to a surface, similar analysis is applicable for fiber optic pairs at other angles. When a fiber optic is not perpendicular to a surface, it generally illuminates an elliptical area. Similarly, the acceptance area of a receiver fiber optic generally becomes elliptical. As the fiber optic pair is moved closer to the surface, the receiver fiber optic also will detect a maximal value at a peaking height independent of the surface color or characteristics. The maximal intensity value measured when the fiber optic pair is not perpendicular to the surface, however, will be less than the maximal intensity value measured when the fiber optic pair is perpendicular to the surface.

[0101] Referring now to FIGS. 5A and 5B, the intensity of light received as a fiber optic source-receiver pair is moved to and from a surface will now be described. FIG. 5A illustrates the intensity of the received light as a function of time. Corresponding FIG. 5B illustrates the height of the fiber optic pair from the surface of the object being measured. FIGS. 5A and 5B illustrate (for ease of discussion) a relatively uniform rate of motion of the fiber optic pair to and from the surface of the object being measured (although similar illustrations/analysis would be applicable for non-uniform rates as well).

[0102] FIG. 5A illustrates the intensity of received light as the fiber optic pair is moved to and then from a surface. While FIG. 5A illustrates the intensity relationship for a single receiver fiber optic, similar intensity relationships would be expected to be observed for other receiver fiber optics, such as, for example, the multiple receiver fiber optics of FIGS. 1 and 2. In general with the preferred embodiment described above, all fifteen fiber optic receivers (of fibers 7) will exhibit curves similar to that illustrated in FIG. 5A.

[0103] FIG. 5A illustrates five regions. In region 1, the probe is moved towards the surface of the object being measured, which causes the received light intensity to increase. In region 2, the probe is moved past the peaking height, and the received light intensity peaks and then falls off sharply. In region 3, the probe essentially is in contact with the surface of the object being measured. As illustrated, the received intensity in region 3 will vary depending upon the translucence of the object being measured. If the object is opaque, the received light intensity will be very low, or almost zero (perhaps out of range of the sensing circuitry). If the object is translucent, however, the light intensity will be quite high, but in general should be less than the peak value. In region 4, the probe is lifted and the light intensity rises sharply to a maximum value. In region 5, the probe is lifted further away from the object, and the light intensity decreases again.

[0104] As illustrated, two peak intensity values (discussed as P1 and P2 below) should be detected as the fiber optic pair moves to and from the object at the peaking height h_p . If peaks P1 and P2 produced by a receiver fiber optic are the same value, this generally is an indication that the probe has been moved to and from the surface of the object to be measured in a consistent manner. If peaks P1 and P2 are of different values, then these may be an indication that the probe was not moved to and from the surface of the object

in a desired manner, or that the surface is curved or textured, as described more fully herein. In such a case, the data may be considered suspect and rejected. In addition, peaks P1 and P2 for each of the perimeter fiber optics (see, e.g., FIG. 2) should occur at the same peaking height (assuming the geometric attributes of the perimeter fiber optics, such as aperture, diameter and spacing from the source fiber optic, etc.). Thus, the perimeter fiber optics of a probe moved in a consistent, perpendicular manner to and from the surface of the object being measured should have peaks P1 and P2 that occur at the same height. Monitoring receiver fibers from the perimeter receiver fiber optics and looking for simultaneous (or near simultaneous, e.g., within a predetermined range) peaks P1 and P2 provides a mechanism for determining if the probe is held at a desired perpendicular angle with respect to the object being measured.

[0105] In addition, the relative intensity level in region 3 serves as an indication of the level of translucency of the object being measured. Again, such principles generally are applicable to the totality of receiver fiber optics in the probe (see, e.g., fibers 7 of FIGS. 1 and 3). Based on such principles, measurement techniques that may be applicable with respect to embodiments disclosed herein will now be described.

[0106] FIG. 6 is a flow chart illustrating a general measuring technique that may be used in accordance with certain embodiments of the present invention. Step 49 indicates the start or beginning of a color/optical measurement. During step 49, any equipment initialization, diagnostic or setup procedures may be performed. Audio or visual information or other indicia may be given to the operator to inform the operator that the system is available and ready to take a measurement. Initiation of the color/optical measurement commences by the operator moving the probe towards the object to be measured, and may be accompanied by, for example, activation of switch 17 (see FIG. 1).

[0107] In step 50, the system on a continuing basis monitors the intensity levels for the receiver fiber optics (see, e.g., fibers 7 of FIG. 1). If the intensity is rising, step 50 is repeated until a peak is detected. If a peak is detected, the process proceeds to step 52. In step 52, measured peak intensity P1, and the time at which such peak occurred, are stored in memory (such as in memory included as a part of microprocessor 10), and the process proceeds to step 54. In step 54, the system continues to monitor the intensity levels of the receiver fiber optics. If the intensity is falling, step 54 is repeated. If a "valley" or plateau is detected (i.e., the intensity is no longer falling, which generally indicates contact or near contact with the object), then the process proceeds to step 56. In step 56, the measured surface intensity (IS) is stored in memory, and the process proceeds to step 58. In step 58, the system continues to monitor the intensity levels of the receiver fibers. If the intensity is rising, step 58 is repeated until a peak is detected. If a peak is detected, the process proceeds to step 60. In step 60, measured peak intensity P2, and the time at which such peak occurred, are stored in memory, and the process proceeds to step 62. In step 62, the system continues to monitor the intensity levels of the receiver fiber optics. Once the received intensity levels begin to fall from peak P2, the system perceives that region 5 has been entered (see, e.g., FIG. 5A), and the process proceeds to step 64.

[0108] In step 64, the system, under control of microprocessor 10, may analyze the collected data taken by the sensing circuitry for the various receiver fiber optics. In step 64, peaks P1 and P2 of one or more of the various fiber optics may be compared. If any of peaks P1 and P2 for any of the various receiver fiber optics have unequal peak values, then the data may be rejected, and the entire color measuring process repeated. Again, unequal values of peaks P1 and P2 may be indicative, for example, that the probe was moved in a non-perpendicular or otherwise unstable manner (i.e., angular or lateral movement), and, for example, peak P1 may be representative of a first point on the object, while peak P2 may be representative of a second point on the object. As the data is suspect, in a preferred embodiment of the present invention, data taken in such circumstances are rejected in step 64.

[0109] If the data are not rejected in step 64, the process proceeds to step 66. In step 66, the system analyzes the data taken from the neutral-density-filtered receivers from each of the perimeter fiber optics (e.g., R1 to R3 of FIG. 2). If the peaks of the perimeter fiber optics did not occur at or about the same point in time, this may be indicative, for example, that the probe was not held perpendicular to the surface of the object being measured. As non-perpendicular alignment of the probe with the surface of the object being measured may cause suspect results, in a preferred embodiment of the present invention, data taken in such circumstances are rejected in step 66. In one preferred embodiment, detection of simultaneous or near simultaneous peaking (peaking within a predetermined range of time) serves as an acceptance criterion for the data, as perpendicular alignment generally is indicated by simultaneous or near simultaneous peaking of the perimeter fiber optics. In other embodiments, step 66 includes an analysis of peak values P1 and P2 of the perimeter fiber optics. In such embodiments, the system seeks to determine if the peak values of the perimeter fiber optics (perhaps normalized with any initial calibration data) are equal within a defined range. If the peak values of the perimeter fiber optics are within the defined range, the data may be accepted, and if not, the data may be rejected. In still other embodiments, a combination of simultaneous peaking and equal value detection are used as acceptance/rejection criteria for the data, and/or the operator may have the ability (such as through key pad switches 12) to control one or more of the acceptance criteria ranges. With such capability, the sensitivity of the system may be controllably altered by the operator depending upon the particular application and operative environment, etc.

[0110] If the data are not rejected in step 66, the process proceeds to step 68. In step 68, the data may be processed in a desired manner to produce output color/optical measurement data. For example, such data may be normalized in some manner, or adjusted based on temperature compensation, or translucency data, or gloss data, or surface texture data or nonperpendicular angle data or other data detected by the system. The data also may be converted to different display or other formats, depending on the intended use of the data. In addition, the data indicative of the translucence of the object and/or glossiness of the object also may be quantified and/or displayed in step 68. After step 68, the process may proceed to starting step 49, or the process may be terminated, etc. As indicated previously, such data also

may be compared with previously-stored data for purposes of making assessments or predictions, etc., of a current or future condition or status.

[0111] In accordance with the process illustrated in FIG. 6, three light intensity values (P1, P2 and IS) are stored per receiver fiber optic to make color and translucency, etc., measurements. If stored peak values P1 and P2 are not equal (for some or all of the receivers), this is an indication that the probe was not held steady over one area, and the data may be rejected (in other embodiments, the data may not be rejected, although the resulting data may be used to produce an average of the measured data). In addition, peak values P1 and P2 for the three neutral density perimeter fiber optics should be equal or approximately equal; if this is not the case, then this is an indication that the probe was not held perpendicular or a curved surface is being measured. In other embodiments, the system attempts to compensate for curved surfaces and/or non-perpendicular angles. In any event, if the system cannot make a color/optical measurement, or if the data is rejected because peak values P1 and P2 are unequal to an unacceptable degree or for some other reason, then the operator is notified so that another measurement or other action may be taken (such as adjust the sensitivity).

[0112] With a system constructed and operating as described above, color/optical measurements may be taken of an object, with accepted data having height and angular dependencies removed. Data not taken at the peaking height, or data not taken with the probe perpendicular to the surface of the object being measured, etc., are rejected in a certain embodiments. In other embodiments, data received from the perimeter fiber optics may be used to calculate the angle of the probe with respect to the surface of the object being measured, and in such embodiments non-perpendicular or curved surface data may be compensated instead of rejected. It also should be noted that peak values P1 and P2 for the neutral density perimeter fiber optics provide a measurement of the luminance (gray value) of the surface of the object being measured, and also may serve to quantify the optical properties.

[0113] The translucency of the object being measured may be quantified as a ratio or percentage, such as, for example, $(IS/P1) \times 100\%$. In other embodiments, other methods of quantifying translucency data provided in accordance with the present invention are utilized, such as some other arithmetic function utilizing IS and P1 or P2, etc. Translucence information, as would be known to those in the art, could be used to quantify and/or adjust the output color data, etc.

[0114] In another particular aspect of the present invention, data generated in accordance with the present invention may be used to implement an automated material mixing/generation machine and/or method. Certain objects/materials, such as dental prostheses or fillings, are made from porcelain or other powders/resins/materials or tissue substitutes that may be combined in the correct ratios or modified with additives to form the desired color of the object/prosthesis. Certain powders often contain pigments that generally obey Beer's law and/or act in accordance with Kubelka-Munk equations and/or Saunderson equations (if needed) when mixed in a recipe. Color and other data taken from a measurement in accordance with the present invention may be used to determine or predict desired quantities

of pigment or other materials for the recipe. Porcelain powders and other materials are available in different colors, opacities, etc. Certain objects, such as dental prostheses, may be layered to simulate the degree of translucency of the desired object (such as to simulate a human tooth). Data generated in accordance with the present invention also may be used to determine the thickness and position of the porcelain or other material layers to more closely produce the desired color, translucency, surface characteristics, etc. In addition, based on fluorescence data for the desired object, the material recipe may be adjusted to include a desired quantity of fluorescing-type material. In yet other embodiments, surface characteristics (such as texture) information (as more fully described herein) may be used to add a texturing material to the recipe, all of which may be carried out in accordance with the present invention. In yet other embodiments, the degree of surface polish to the prosthesis may be monitored or adjusted, based on gloss data derived in accordance with the present invention.

[0115] For more information regarding such pigment-material recipe type technology, reference may be made to: "The Measurement of Appearance," Second Edition, edited by Hunter and Harold, copyright 1987; "Principles of Color Technology," by Billmeyer and Saltzman, copyright 1981; and "Pigment Handbook," edited by Lewis, copyright 1988. All of the foregoing are believed to have been published by John Wiley & Sons, Inc., New York, N.Y., and all of which are hereby incorporated by reference.

[0116] In certain operative environments, such as dental applications, contamination of the probe is of concern. In certain embodiments of the present invention, implements to reduce such contamination are provided.

[0117] FIGS. 7A and 7B illustrate a protective cap that may be used to fit over the end of probe tip 1. Such a protective cap consists of body 80, the end of which is covered by optical window 82, which in a preferred embodiment consists of a structure having a thin sapphire window. In a preferred embodiment, body 80 consists of stainless steel. Body 80 fits over the end of probe tip 1 and may be held into place by, for example, indentations formed in body 80, which fit with ribs 84 (which may be a spring clip or other retainer) formed on probe tip 1. In other embodiments, other methods of affixing such a protective cap to probe tip 1 are utilized. The protective cap may be removed from probe tip 1 and sterilized in a typical autoclave, hot steam, chemiclave or other sterilizing system.

[0118] The thickness of the sapphire window should be less than the peaking height of the probe in order to preserve the ability to detect peaking in accordance with the present invention, and preferably has a thickness less than the critical height at which the source/receiver cones overlap (see FIGS. 4B and 4C). It also is believed that sapphire windows may be manufactured in a reproducible manner, and thus any light attenuation from one cap to another may be reproducible. In addition, any distortion of the color/optical measurements produced by the sapphire window may be calibrated out by microprocessor 10.

[0119] Similarly, in other embodiments body 80 has a cap with a hole in the center (as opposed to a sapphire window), with the hole positioned over the fiber optic source/receivers.

[0120] The cap with the hole serves to prevent the probe from coming into contact with the surface, thereby reducing

the risk of contamination. It should be noted that, with such embodiments, the hole is positioned so that light from/to the light source/receiver elements of the probe tip is not adversely affected by the cap.

[0121] FIGS. 8A and 8B illustrate another embodiment of a removable probe tip that may be used to reduce contamination in accordance with the present invention. As illustrated in FIG. 8A, probe tip 88 is removable, and includes four (or a different number, depending upon the application) fiber optic connectors 90, which are positioned within optical guard 92 coupled to connector 94. Optical guard 92 serves to prevent "cross talk" between adjacent fiber optics. As illustrated in FIG. 8B, in this embodiment removable tip 88 is secured in probe tip housing 93 by way of spring clip 96 (other removable retaining implements are utilized in other embodiments). Probe tip housing 93 may be secured to base connector 95 by a screw or other conventional fitting. It should be noted that, with this embodiment, different size tips may be provided for different applications, and that an initial step of the process may be to install the properly-sized (or fitted tip) for the particular application. Removable tip 88 also may be sterilized in a typical autoclave, hot steam, chemiclave or other sterilizing system, or disposed of. In addition, the entire probe tip assembly is constructed so that it may be readily disassembled for cleaning or repair. In certain embodiments the light source/receiver elements of the removable tip are constructed of glass, silica or similar materials, thereby making them particularly suitable for autoclave or similar high temperature/pressure cleaning methods, which in certain other embodiments the light source/receiver elements of the removable tip are constructed of plastic or other similar materials, which may be of lower cost, thereby making them particularly suitable for disposable-type removable tips, etc.

[0122] In still other embodiments, a plastic, paper or other type shield (which may be disposable, cleanable/reusable or the like) may be used in order to address any contamination concerns that may exist in the particular application. In such embodiments, the methodology may include positioning such a shield over the probe tip prior to taking color/optical measurements, and may include removing and disposing/cleaning the shield after taking color/optical measurements, etc.

[0123] A further embodiment of the present invention utilizing an alternate removable probe tip will now be described with reference to FIGS. 19A-19C. As illustrated in FIG. 19A, this embodiment utilizes removable, coherent light conduit 340 as a removable tip. Light conduit 340 is a short segment of a light conduit that preferably may be a fused bundle of small fiber optics, in which the fibers are held essentially parallel to each other, and the ends of which are highly polished. Cross-section 350 of light conduit 340 is illustrated in FIG. 19B. Light conduits similar to light conduit 340 have been utilized in what are known as borescopes, and also have been utilized in medical applications such as endoscopes.

[0124] Light conduit 340 in this embodiment serves to conduct light from the light source to the surface of the object being measured, and also to receive reflected light from the surface and conduct it to light receiver fiber optics 346 in probe handle 344. Light conduit 340 is held in position with respect to fiber optics 346 by way or com-

pression jaws **342** or other suitable fitting or coupled that reliably positions light conduit **340** so as to couple light effectively to/from fiber optics **346**. Fiber optics **346** may be separated into separate fibers/light conduits **348**, which may be coupled to appropriate light sensors, etc., as with previously described embodiments.

[0125] In general, the aperture of the fiber optics used in light conduit **340** may be chosen to match the aperture of the fiber optics for the light source and the light receivers or alternately the light conduit aperture could be greater than or equal to the largest source or receiver aperture. Thus, the central part of the light conduit may conduct light from the light source and illuminate the surface as if it constituted a single fiber within a bundle of fibers. Similarly, the outer portion of the light conduit may receive reflected light and conduct it to light receiver fiber optics as if it constituted single fibers. Light conduit **340** has ends that preferably are highly polished and cut perpendicular, particularly the end coupling light to fiber optics **346**. Similarly, the end of fiber optics **346** abutting light conduit **340** also is highly polished and cut perpendicular to a high degree of accuracy in order to minimize light reflection and cross talk between the light source fiber optic and the light receiver fiber optics and between adjacent receiver fiber optics. Light conduit **340** offers significant advantages including in the manufacture and installation of such a removable tip. For example, the probe tip need not be particularly aligned with the probe tip holder; rather, it only needs to be held against the probe tip holder such as with a compression mechanism (such as with compression jaws **342**) so as to couple light effectively to/from fiber optics **346**. Thus, such a removable tip mechanism may be implemented without alignment tabs or the like, thereby facilitating easy installation of the removable probe tip. Such an easy installable probe tip may thus be removed and cleaned prior to installation, thereby facilitating use of the color/optical measuring apparatus by dentists, medical professions or others working in an environment in which contamination may be a concern. Light conduit **340** also may be implemented, for example, as a small section of light conduit, which may facilitate easy and low cost mass production and the like.

[0126] A further embodiment of such a light conduit probe tip is illustrated as light conduit **352** in FIG. **19C**. Light conduit **352** is a light conduit that is narrower on one end (end **354**) than the other end (end **356**). Contoured/tapered light conduits such as light conduit **352** may be fabricated by heating and stretching a bundle of small fiber optics as part of the fusing process. Such light conduits have an additional interesting property of magnification or reduction. Such phenomena result because there are the same number of fibers in both ends. Thus, light entering narrow end **354** is conducted to wider end **356**, and since wider end **356** covers a larger area, it has a magnifying affect.

[0127] Light conduit **352** of FIG. **19C** may be utilized in a manner similar to light conduit **340** (which in general may be cylindrical) of FIG. **19A**. Light conduit **352**, however, measures smaller areas because of its reduced size at end **354**. Thus, a relatively larger probe body may be manufactured where the source fiber optic is spaced widely from the receiver fiber optics, which may provide an advantage in reduced light reflection and cross talk at the junction, while still maintaining a small probe measuring area. Additionally, the relative sizes of narrow end **354** of light conduit **352** may

be varied. This enables the operator to select the size/characteristic of the removable probe tip according to the conditions in the particular application. Such ability to select sizes of probe tips provides a further advantage in making optical characteristics measurements in a variety of applications and operative environments.

[0128] As should be apparent to those skilled in the art in view of the disclosures herein, light conduits **340** and **356** of FIGS. **19A** and **19C** need not necessarily be cylindrical/tapered as illustrated, but may be curved such as for specialty applications, in which a curved probe tip may be advantageously employed (such as in a confined or hard-to-reach place). It also should be apparent that light conduit **352** of FIG. **19C** may be reversed (with narrow end **354** coupling light into fiber optics **346**, etc., and wide end **356** positioned in order to take measurements) in order to cover larger areas.

[0129] With reference to FIG. **9**, a tristimulus embodiment will now be described, which may aid in the understanding of, or may be used in conjunction with, certain embodiments disclosed herein. In general, the overall system depicted in FIG. **1** and discussed in detail elsewhere herein may be used with this embodiment. FIG. **9** illustrates a cross section of the probe tip fiber optics used in this embodiment.

[0130] Probe tip **100** includes central source fiber optic **106**, surrounded by (and spaced apart from) three perimeter receiver fiber optics **104** and three color receiver fiber optics **102**. Three perimeter receiver fiber optics **104** are optically coupled to neutral density filters and serve as height/angle sensors in a manner analogous to the embodiment describe above. Three color receiver fiber optics are optically coupled to suitable tristimulus filters, such as red, green and blue filters. With this embodiment, a measurement may be made of tristimulus color values of the object, and the process described with reference to FIG. **6** generally is applicable to this embodiment. In particular, perimeter fiber optics **104** may be used to detect simultaneous peaking or otherwise whether the probe is perpendicular to the object being measured.

[0131] FIG. **10A** illustrates another such embodiment, similar to the embodiment discussed with reference to FIG. **9**. Probe tip **100** includes central source fiber optic **106**, surrounded by (and spaced apart from) three perimeter receiver fiber optics **104** and a plurality of color receiver fiber optics **102**. The number of color receiver fiber optics **102**, and the filters associated with such receiver fiber optics **102**, may be chosen based upon the particular application. As with the embodiment of FIG. **9**, the process described with reference to FIG. **6** generally is applicable to this embodiment.

[0132] FIG. **10B** illustrates another such embodiment in which there are a plurality of receiver fiber optics that surround central source fiber optic **240**. The receiver fiber optics are arranged in rings surrounding the central source fiber optic. FIG. **10B** illustrates three rings of receiver fiber optics (consisting of fiber optics **242**, **244** and **246**, respectively), in which there are six receiver fiber optics per ring. The rings may be arranged in successive larger circles as illustrated to cover the entire area of the end of the probe, with the distance from each receiver fiber optic within a given ring to the central fiber optic being equal (or approximately so). Central fiber optic **240** is utilized as the light

source fiber optic and is connected to the light source in a manner similar to light source fiber optic **5** illustrated in FIG. **1**.

[0133] The plurality of receiver fiber optics are each coupled to two or more fiber optics in a manner similar to the arrangement illustrated in FIG. **1** for splicing connector **4**. One fiber optic from such a splicing connector for each receiver fiber optic passes through a neutral density filter and then to light sensor circuitry similar to the light sensor circuitry illustrated in FIG. **3**. A second fiber optic from the splicing connector per receiver fiber optic passes through a Sharp Cutting Wrattan Gelatin Filter (or notch filter as previously described) and then to light sensor circuitry as discussed elsewhere herein. Thus, each of the receiver fiber optics in the probe tip includes both color measuring elements and neutral light measuring or "perimeter" elements.

[0134] FIG. **10D** illustrates the geometry of probe **260** (such as described above) illuminating an area on flat diffuse surface **272**. Probe **260** creates light pattern **262** that is reflected diffusely from surface **272** in uniform hemispherical pattern **270**. With such a reflection pattern, the reflected light that is incident upon the receiving elements in the probe will be equal (or nearly equal) for all elements if the probe is perpendicular to the surface as described above herein.

[0135] FIG. **10C** illustrates a probe illuminating rough surface **268** or a surface that reflects light unevenly. The reflected light will exhibit hot spots or regions **266** where the reflected light intensity is considerably greater than it is on other areas **264**. The reflected light pattern will be uneven when compared to a smooth surface as illustrate in FIG. **10D**.

[0136] Since a probe as illustrated in FIG. **10B** has a plurality of receiver fiber optics arranged over a large surface area, the probe may be utilized to determine the surface texture of the surface as well as being able to measure the color and translucency, etc., of the surface as described earlier herein. If the light intensity received by the receiver fiber optics is equal for all fiber optics within a given ring of receiver fiber optics, then generally the surface is smooth. If, however, the light intensity of receiver fibers in a ring varies with respect to each other, then generally the surface is rough. By comparing the light intensities measured within receiver fiber optics in a given ring and from ring to ring, the texture and other characteristics of the surface may be quantified.

[0137] FIG. **11** illustrates an embodiment of the present invention in which linear optical sensors and a color gradient filter are utilized instead of light sensors **8** (and filters **22**, etc.). Receiver fiber optics **7**, which may be optically coupled to probe tip **1** as with the embodiment of FIG. **1**, are optically coupled to linear optical sensor **112** through color gradient filter **110**. In this embodiment, color gradient filter **110** may consist of series of narrow strips of cut-off type filters on a transparent or open substrate, which are constructed so as to positionally correspond to the sensor areas of linear optical sensor **112**. An example of a commercially available linear optical sensor **112** is Texas Instruments part number TSL213, which has 61 photo diodes in a linear array. Light receiver fiber optics **7** are arranged correspondingly in a line over linear optical sensor **112**. The number of receiver fiber optics may be chosen for the particular application, so long as enough are included to more or less evenly cover the

full length of color gradient filter **110**. With this embodiment, the light is received and output from receiver fiber optics **7**, and the light received by linear optical sensor **112** is integrated for a short period of time (determined by the light intensity, filter characteristics and desired accuracy). The output of linear array sensor **112** is digitized by ADC **114** and output to microprocessor **116** (which may the same processor as microprocessor **10** or another processor).

[0138] In general, with the embodiment of FIG. **11**, perimeter receiver fiber optics may be used as with the embodiment of FIG. **1**, and in general the process described with reference to FIG. **6** is applicable to this embodiment.

[0139] FIG. **12** illustrates an embodiment of the present invention in which a matrix optical sensor and a color filter grid are utilized instead of light sensors **8** (and filters **22**, etc.). Receiver fiber optics **7**, which may be optically coupled to probe tip **1** as with the embodiment of FIG. **1**, are optically coupled to matrix optical sensor **122** through filter grid **120**. Filter grid **120** is a filter array consisting of a number of small colored spot filters that pass narrow bands of visible light. Light from receiver fiber optics **7** pass through corresponding filter spots to corresponding points on matrix optical sensor **122**. In this embodiment, matrix optical sensor **122** may be a monochrome optical sensor array, such as CCD-type or other type of light sensor element such as may be used in a video camera. The output of matrix optical sensor **122** is digitized by ADC **124** and output to microprocessor **126** (which may the same processor as microprocessor **10** or another processor). Under control of microprocessor **126**, matrix optical sensor **126** collects data from receiver fiber optics **7** through color filter grid **120**.

[0140] In general, with the embodiment of FIG. **12**, perimeter receiver fiber optics may be used as with the embodiment of FIG. **1**, and in general the process described with reference to FIG. **6** also is applicable to this embodiment.

[0141] In general with the embodiments of FIGS. **11** and **12**, the color filter grid may consist of sharp cut off filters as described earlier or it may consist of notch filters. As will be apparent to one skilled in the art, they may also be constructed of a diffraction grating and focusing mirrors such as those utilized in conventional monochromators.

[0142] As will be clear from the foregoing description, with the present invention a variety of types of spectral color/optical photometers (or tristimulus-type colorimeters) may be constructed, with perimeter receiver fiber optics used to collect color/optical data essentially free from height and angular deviations. In addition, in certain embodiments, the present invention enables color/optical measurements to be taken at a peaking height from the surface of the object being measured, and thus color/optical data may be taken without physical contact with the object being measured (in such embodiments, the color/optical data is taken only by passing the probe through region **1** and into region **2**, but without necessarily going into region **3** of FIGS. **5A** and **5B**). Such embodiments may be utilized if contact with the surface is undesirable in a particular application. In the embodiments described earlier, however, physical contact (or near physical contact) of the probe with the object may allow all five regions of FIGS. **5A** and **5B** to be utilized, thereby enabling measurements to be taken such that translucency informa-

tion also may be obtained. Both types of embodiments generally are within the scope of the invention described herein.

[0143] Additional description will now be provided with respect to cut-off filters of the type described in connection with the preferred embodiment(s) of FIGS. 1 and 3 (such as filters 22 of FIG. 3). FIG. 13A illustrates the properties of a single Kodak Sharp Cutting Wratten Gelatin Filter discussed in connection with FIG. 3. Such a cut-off filter passes light below a cut-off frequency (i.e., above a cut-off wavelength). Such filters may be manufactured to have a wide range of cut-off frequencies/wavelengths. FIG. 13B illustrates a number of such filters, twelve in a preferred embodiment, with cut-off frequencies/wavelengths chosen so that essentially the entire visible band is covered by the collection of cut-off filters.

[0144] FIGS. 14A and 14B illustrate exemplary intensity measurements using a cut-off filter arrangement such as illustrated in FIG. 13B, first in the case of a white surface being measured (FIG. 14A), and also in the case of a blue surface being measured (FIG. 14B). As illustrated in FIG. 14A, in the case of a white surface, the neutrally filtered perimeter fiber optics, which are used to detect height and angle, etc., generally will produce the highest intensity (although this depends at least in part upon the characteristics of the neutral density filters). As a result of the stepped cut-off filtering provided by filters having the characteristics illustrated in FIG. 13B, the remaining intensities will gradually decrease in value as illustrated in FIG. 14A. In the case of a blue surface, the intensities will decrease in value generally as illustrated in FIG. 14B. Regardless of the surface, however, the intensities out of the filters will always decrease in value as illustrated, with the greatest intensity value being the output of the filter having the lowest wavelength cut-off value (i.e., passes all visible light up to blue), and the lowest intensity value being the output of the filter having the highest wavelength cut-off (i.e., passes only red visible light). As will be understood from the foregoing description, any color data detected that does not fit the decreasing intensity profiles of FIGS. 14A and 14B may be detected as an abnormality, and in certain embodiments detection of such a condition results in data rejection, generation of an error message or initiation of a diagnostic routine, etc.

[0145] Reference should be made to the FIGS. 1 and 3 and the related description for a detailed discussion of how such a cut-off filter arrangement may be utilized in accordance with the present invention.

[0146] FIG. 15 is a flow chart illustrating audio tones that may be used in certain preferred embodiments of the present invention. It has been discovered that audio tones (such as tones, beeps, voice or the like such as will be described) present a particularly useful and instructive means to guide an operator in the proper use of a color measuring system of the type described herein.

[0147] The operator may initiate a color/optical measurement by activation of a switch (such as switch 17 of FIG. 1) at step 150. Thereafter, if the system is ready (set-up, initialized, calibrated, etc.), a lower-the-probe tone is emitted (such as through speaker 16 of FIG. 1) at step 152. The system attempts to detect peak intensity P1 at step 154. If a peak is detected, at step 156 a determination is made

whether the measured peak P1 meets the applicable criteria (such as discussed above in connection with FIGS. 5A, 5B and 6). If the measured peak P1 is accepted, a first peak acceptance tone is generated at step 160. If the measured peak P1 is not accepted, an unsuccessful tone is generated at step 158, and the system may await the operator to initiate a further color/optical measurement. Assuming that the first peak was accepted, the system attempts to detect peak intensity P2 at step 162. If a second peak is detected, at step 164 a determination is made whether the measured peak P2 meets the applicable criteria. If the measured peak P2 is accepted the process proceeds to color calculation step 166 (in other embodiments, a second peak acceptance tone also is generated at step 166). If the measured peak P2 is not accepted, an unsuccessful tone is generated at step 158, and the system may await the operator to initiate a further color/optical measurement. Assuming that the second peak was accepted, a color/optical calculation is made at step 166 (such as, for example, microprocessor 10 of FIG. 1 processing the data output from light sensors 8, etc.). At step 168, a determination is made whether the color calculation meets the applicable criteria. If the color calculation is accepted, a successful tone is generated at step 170. If the color calculation is not accepted, an unsuccessful tone is generated at step 158, and the system may await the operator to initiate a further color/optical measurement.

[0148] With unique audio tones presented to an operator in accordance with the particular operating state of the system, the operator's use of the system may be greatly facilitated. Such audio information also tends to increase operator satisfaction and skill level, as, for example, acceptance tones provide positive and encouraging feedback when the system is operated in a desired manner.

[0149] Further embodiments of the present invention will now be described with reference to FIGS. 16-18. The previously described embodiments generally rely on movement of the probe with respect to the object being measured. While such embodiments provide great utility in many applications, in certain applications, such as robotics, industrial control, automated manufacturing, etc. (such as positioning the object and/or the probe to be in proximity to each other, detecting color/optical properties of the object, and then directing the object, e.g., sorting, based on the detected color/optical properties, for further industrial processing, packaging, etc.) it may be desired to have the measurement made with the probe held or positioned substantially stationary above the surface of the object to be measured (in such embodiments, the positioned probe may not be handheld as with certain other embodiments).

[0150] FIG. 16 illustrates such a further embodiment. The probe of this embodiment includes a plurality of perimeter sensors and a plurality of color sensors coupled to receivers 312-320. The color sensors and related components, etc., may be constructed to operate in a manner analogous to previously described embodiments. For example, fiber optic cables or the like may couple light from source 310 that is received by receivers 312-320 through sharp cut-off filters or notch filters, with the received light measured over precisely defined wavelengths (see, e.g., FIGS. 1, 3 and 11-14 and related description). Color/optical characteristics of the object may be determined from the plurality of color sensor measurements, which may include three such sensors in the case of a tristimulus instrument, or 8, 12, 15 or more color

sensors for a more full bandwidth system (the precise number may be determined by the desired color resolution, etc.).

[0151] With this embodiment, a relatively greater number of perimeter sensors are utilized (as opposed, for example, to the three perimeter sensors used in certain preferred embodiments of the present invention). As illustrated in FIG. 16, a plurality of triads of receivers 312-320 coupled to perimeter sensors are utilized, where each triad in the preferred implementation consists of three fiber optics positioned equal distance from light source 310, which in the preferred embodiment is a central light source fiber optic. The triads of perimeter receivers/sensors may be configured as concentric rings of sensors around the central light source fiber optic. In FIG. 16, ten such triad rings are illustrated, although in other embodiments a lesser or greater number of triad rings may be utilized, depending upon the desired accuracy and range of operation, as well as cost considerations and the like.

[0152] The probe illustrated in FIG. 16 may operate within a range of heights (i.e., distances from the object being measured). As with earlier embodiments, such height characteristics are determined primarily by the geometry and constituent materials of the probe, with the spacing of the minimal ring of perimeter sensors determining the minimal height, and the spacing of the maximal ring of perimeter sensors determining the maximum height, etc. It therefore is possible to construct probes of various height ranges and accuracy, etc., by varying the number of perimeter sensor rings and the range of ring distances from the central source fiber optic. It should be noted that such embodiments may be particularly suitable when measuring similar types of materials, etc.

[0153] As described earlier, the light receiver elements for the plurality of receivers/perimeter sensors may be individual elements such as Texas Instruments TSL230 light-to-frequency converters, or may be constructed with rectangular array elements or the like such as may be found in a CCD camera. Other broadband-type of light measuring elements are utilized in other embodiments. Given the large number of perimeter sensors used in such embodiments (such as 30 for the embodiment of FIG. 16), an array such as CCD camera-type sensing elements may be desirable. It should be noted that the absolute intensity levels of light measured by the perimeter sensors is not as critical to such embodiments of the present invention; in such embodiments differences between the triads of perimeter light sensors are advantageously utilized in order to obtain optical measurements.

[0154] Optical measurements may be made with such a probe by holding/positioning the probe near the surface of the object being measured (i.e., within the range of acceptable heights of the particular probe). The light source providing light to light source 310 is turned on and the reflected light received by receivers 312-320 (coupled to the perimeter sensors) is measured. The light intensity of the rings of triad sensors is compared. Generally, if the probe is perpendicular to the surface and if the surface is flat, the light intensity of the three sensors of each triad should be approximately equal. If the probe is not perpendicular to the surface or if the surface is not flat, the light intensity of the three sensors within a triad will not be equal. It is thus possible to

determine if the probe is perpendicular to the surface being measured, etc. It also is possible to compensate for non-perpendicular surfaces by mathematically adjusting the light intensity measurements of the color sensors with the variance in measurements of the triads of perimeter sensors.

[0155] Since the three sensors forming triads of sensors are at different distances (radii) from central light source 310, it is expected that the light intensities measured by light receivers 312-320 and the perimeter sensors will vary. For any given triad of sensors, as the probe is moved closer to the surface, the received light intensity will increase to a maximum and then sharply decrease as the probe is moved closer to the surface. As with previously-described embodiments, the intensity decreases rapidly as the probe is moved less than the peaking height and decreases rapidly to zero or almost zero for opaque objects. The value of the peaking height depends principally upon the distance of the particular receiver from light source 310. Thus, the triads of sensors will peak at different peaking heights. By analyzing the variation in light values received by the triads of sensors, the height of the probe can be determined. Again, this is particularly true when measuring similar types of materials. As discussed earlier, comparisons with previously-stored data also may be utilized to make such determinations or assessments, etc.

[0156] The system initially is calibrated against a neutral background (e.g., a gray background), and the calibration values are stored in non-volatile memory (see, e.g., processor 10 of FIG. 1). For any given color or intensity, the intensity for the receivers/perimeter sensors (independent of distance from the central source fiber optic) in general should vary equally. Hence, a white surface should produce the highest intensities for the perimeter sensors, and a black surface will produce the lowest intensities. Although the color of the surface will affect the measured light intensities of the perimeter sensors, it should affect them substantially equally. The height of the probe from the surface of the object, however, will affect the triads of sensors differently. At the minimal height range of the probe, the triad of sensors in the smallest ring (those closest to the source fiber optic) will be at or about their maximal value. The rest of the rings of triads will be measuring light at intensities lower than their maximal values. As the probe is raised/positioned from the minimal height, the intensity of the smallest ring of sensors will decrease and the intensity of the next ring of sensors will increase to a maximal value and will then decrease in intensity as the probe is raised/positioned still further. Similarly for the third ring, fourth ring and so on. Thus, the pattern of intensities measured by the rings of triads will be height dependent. In such embodiments, characteristics of this pattern may be measured and stored in non-volatile RAM look-up tables (or the like) for the probe by calibrating it in a fixture using a neutral color surface. Again, the actual intensity of light is not as important in such embodiments, but the degree of variance from one ring of perimeter sensors to another is.

[0157] To determine a measure of the height of the probe from the surface being measured, the intensities of the perimeter sensors (coupled to receivers 312-320) is measured. The variance in light intensity from the inner ring of perimeter sensors to the next ring and so on is analyzed and compared to the values in the look-up table to determine the height of the probe. The determined height of the probe with

respect to the surface thus may be utilized by the system processor to compensate for the light intensities measured by the color sensors in order to obtain reflectivity readings that are in general independent of height. As with previously described embodiments, the reflectivity measurements may then be used to determine optical characteristics of the object being measured, etc.

[0158] It should be noted that audio tones, such as previously described, may be advantageously employed when such an embodiment is used in a handheld configuration. For example, audio tones of varying pulses, frequencies and/or intensities may be employed to indicate the operational status of the instrument, when the instrument is positioned within an acceptable range for color measurements, when valid or invalid color measurements have been taken, etc. In general, audio tones as previously described may be adapted for advantageous use with such further embodiments.

[0159] FIG. 17 illustrates a further such embodiment of the present invention. The preferred implementation of this embodiment consists of a central light source 310 (which in the preferred implementation is a central light source fiber optic), surrounded by a plurality of light receivers 322 (which in the preferred implementation consists of three perimeter light receiver fiber optics). The three perimeter light receiver fiber optics, as with earlier described embodiments, may be each spliced into additional fiber optics that pass to light intensity receivers/sensors, which may be implemented with Texas Instruments TSL230 light to frequency converters as described previously. One fiber of each perimeter receiver is coupled to a sensor and measured full band width (or over substantially the same bandwidth) such as via a neutral density filter, and other of the fibers of the perimeter receivers are coupled to sensors so that the light passes through sharp cut off or notch filters to measure the light intensity over distinct frequency ranges of light (again, as with earlier described embodiments). Thus there are color light sensors and neutral "perimeter" sensors as with previously described embodiments. The color sensors are utilized to determine the color or other optical characteristics of the object, and the perimeter sensors are utilized to determine if the probe is perpendicular to the surface and/or are utilized to compensate for non-perpendicular angles within certain angular ranges.

[0160] In the embodiment of FIG. 17, the angle of the perimeter sensor fiber optics is mechanically varied with respect to the central source fiber optic. The angle of the perimeter receivers/sensors with respect to the central source fiber optic is measured and utilized as described hereinafter. An exemplary mechanical mechanism, the details of which are not critical so long as desired, control movement of the perimeter receivers with respect to the light source is obtained, is described with reference to FIG. 18.

[0161] The probe is held within the useful range of the instrument (determined by the particular configuration and construction, etc.), and a color measurement is initiated. The angle of the perimeter receivers/sensors with respect to the central light source is varied from parallel to pointing towards the central source fiber optic. While the angle is being varied, the intensities of the light sensors for the perimeter sensors (e.g., neutral sensors) and the color sensors is measured and saved along with the angle of the sensors at the time of the light measurement. The light

intensities are measured over a range of angles. As the angle is increased the light intensity will increase to a maximum value and will then decrease as the angle is further increased. The angle where the light values is a maximum is utilized to determine the height of the probe from the surface. As will be apparent to those skilled in the art based on the teachings provided herein, with suitable calibration data, simple geometry or other math, etc., may be utilized to calculate the height based on the data measured during variation of the angle. The height measurement may then be utilized to compensate for the intensity of the color/optical measurements and/or utilized to normalize color values, etc.

[0162] FIG. 18 illustrates an exemplary embodiment of a mechanical arrangement to adjust and measure the angle of the perimeter sensors. Each perimeter receiver/sensor 322 is mounted with pivot arm 326 on probe frame 328. Pivot arm 326 engages central ring 332 in a manner to form a cam mechanism. Central ring 332 includes a groove that holds a portion of pivot arm 326 to form the cam mechanism. Central ring 332 may be moved perpendicular with respect to probe frame 328 via linear actuator 324 and threaded spindle 330. The position of central ring 332 with respect to linear actuator 324 determines the angle of perimeter receivers/sensors 322 with respect to light source 310. Such angular position data vis-à-vis the position of linear actuator 324 may be calibrated in advance and stored in non-volatile memory, and later used to produce color/optical characteristic measurement data as previously described.

[0163] With the foregoing as background, various additional preferred embodiments utilizing variable aperture receivers in order to measure, for example, the degree of gloss of the surface will now be described with references to FIGS. 20A to 22B. Various of the electronics and spectrophotometer/reflectometer implements described above will be applicable to such preferred embodiments.

[0164] Referring to FIG. 20A, a probe utilizing variable aperture receivers will now be described. In FIG. 20A, source A 452 represents a source fiber optic of a small numerical aperture NA, 0.25 for example; receivers B 454 represent receiver fiber optics of a wider numerical aperture, 0.5 for example; receivers C 456 represent receiver fiber optics of the same numerical aperture as source A but is shown with a smaller core diameter; and receivers D 458 represent receiver fiber optics of a wider numerical aperture, 0.5 for example.

[0165] One or more of receiver(s) B 454 (in certain embodiments one receiver B may be utilized, while in other embodiments a plurality of receivers B are utilized, which may be circularly arranged around source A, such as 6 or 8 such receivers B) pass to a spectrometer (see, e.g., FIGS. 1, 3, 11, 12, configured as appropriate for such preferred embodiments). Receiver(s) B 454 are used to measure the spectrum of the reflected light. Receivers C 456 and D 458 pass to broad band (wavelength) optical receivers and are used to correct the measurement made by receiver(s) B. Receivers C 456 and D 458 are used to correct for and to detect whether or not the probe is perpendicular to the surface and to measure/assess the degree of specular versus diffuse reflection (the coefficient of specular reflection, etc.) and to measure the translucency of the material/object.

[0166] FIG. 20B illustrates a refinement of the embodiment of FIG. 20A, in which receivers B 454 are replaced by

a cylindrical arrangement of closely packed, fine optical fibers 454A, which generally surround light source 452 as illustrated. The fibers forming the cylindrical arrangement for receivers B 454A, are divided into smaller groups of fibers and are presented, for example, to light sensors 8 shown in FIG. 1. The number of groups of fibers is determined by the number of light sensors. Alternately, the entire bundle of receiver fibers B 454A is presented to a spectrometer such as a diffraction grating spectrometer of conventional design. As previously described, receivers C 456 and D 458 may be arranged on the periphery thereof. In certain embodiments, receivers C and D may also consist of bundles of closely packed, fine optical fibers. In other embodiments they consist of single fiber optics.

[0167] The assessment of translucency in accordance with embodiments of the present invention have already been described. It should be noted, however, that in accordance with the preferred embodiment both the light reflected from the surface of the material/object (i.e., the peaking intensity) and its associated spectrum and the spectrum of the light when it is in contact with the surface of the material/object may be measured/assessed. The two spectrums typically will differ in amplitude (the intensity or luminance typically will be greater above the surface than in contact with the surface) and the spectrums for certain materials may differ in chrominance (i.e., the structure of the spectrum) as well.

[0168] When a probe in accordance with such embodiments measures the peaking intensity, it in general is measuring both the light reflected from the surface and light that penetrates the surface, gets bulk scattered within the material and re-emerges from the material (e.g., the result of translucency). When the probe is in contact with the surface (e.g., less than the critical height), no light reflecting from the surface can be detected by the receiver fiber optics, and thus any light detected by the receivers is a result of the translucency of the material and its spectrum is the result of scattering within the bulk of the material. The “reflected spectrum” and the “bulk spectrum” in general may be different for different materials, and assessments of such reflected and bulk spectrum provide additional parameters for measuring, assessing and/or characterizing materials, surfaces, objects, teeth, etc., and provide new mechanisms to distinguish translucent and other types of materials.

[0169] In accordance with preferred embodiments of the present invention, an assessment or measurement of the degree of gloss (or specular reflection) may be made. For understanding thereof, reference is made to FIGS. 21 to 22B.

[0170] Referring to FIG. 21, consider two fiber optics, source fiber optic 460 and receiver fiber optic 462, arranged perpendicular to a specular surface as illustrated. The light reflecting from a purely specular surface will be reflected in the form of a cone. As long as the numerical aperture of the receiver fiber optic is greater than or equal to the numerical aperture of the source fiber optic, all the light reflected from the surface that strikes the receiver fiber optic will be within the receiver fiber optic's acceptance cone and will be detected. In general, it does not matter what the numerical aperture of the receiver fiber optic is, so long as it is greater than or equal to the numerical aperture of the source fiber optic. When the fiber optic pair is far from the surface, receiver fiber optic 462 is fully illuminated. Eventually, as the pair approaches surface 464, receiver fiber optic 462 is

only partially illuminated. Eventually, at heights less than or equal to the critical height h_c , receiver fiber optic 462 will not be illuminated. In general, such as for purely specular surfaces, it should be noted that the critical height is a function of the numerical aperture of source fiber optic 460, and is not a function of the numerical aperture of the receiver.

[0171] Referring now to FIGS. 22A and 22B, consider two fiber optics (source 460 and receiver 462) perpendicular to diffuse surface 464A as illustrated in FIG. 22A (FIG. 22B depicts mixed specular/diffuse surface 464B and area of intersection 466B). Source fiber optic 460 illuminates circular area 466A on surface 464A, and the light is reflected from surface 464A. The light, however, will be reflected at all angles, unlike a specular surface where the light will only be reflected in the form of a cone. Receiver fiber optic 462 in general is always illuminated at all heights, although it can only propagate and detect light that strikes its surface at an angle less than or equal to its acceptance angle. Thus, when the fiber optic pair is less than the critical height, receiver fiber optic 462 detects no light. As the height increases above the critical height, receiver fiber optic 462 starts to detect light that originates from the area of intersection of the source and receiver cones as illustrated. Although light may be incident upon receiver fiber optic 462 from other areas of the illuminated circle, it is not detected because it is greater than the acceptance angle of the receiver fiber.

[0172] As the numerical aperture of receiver fiber optic 462 increases, the intensity detected by receiver fiber optic 462 will increase for diffuse surfaces, unlike a specular surface where the received intensity is not a function of receiver fiber optic numerical aperture. Thus, for a probe constructed with a plurality of receiver fiber optics with different numerical apertures, as in preferred embodiments of the present invention, if the surface is a highly glossy surface, both receivers (see, e.g., receivers 456 and 458 of FIG. 20A), will measure the same light intensity. As the surface becomes increasingly diffuse, however receiver D 458 will have a greater intensity than receiver C 456. The ratio of the two intensities from receivers C/D is a measure of, or correlates to, the degree of specular reflection of the material, and may be directly or indirectly used to quantify the “glossiness” of the surface. Additionally, it should be noted that generally receiver C 456 (preferably having the same numerical aperture as source fiber optic A 452) measures principally the specular reflected component. Receiver D 458, on the other hand, generally measures both diffuse and specular components. As will be appreciated by those skilled in the art, such probes and methods utilizing receivers of different/varying numerical apertures may be advantageously utilized, with or without additional optical characteristic determinations as described elsewhere herein, to further quantify materials such as teeth or other objects.

[0173] Referring now to FIG. 23A, additional preferred embodiments will be described. The embodiment of FIG. 23A utilizes very narrow numerical aperture, non-parallel fiber optic receivers 472 and very narrow numerical aperture source fiber optic 470 or utilizes other optical elements to create collimated or nearly collimated source and receiver elements. Central source fiber optic 470 is a narrow numerical aperture fiber optic and receiver fiber optics 472 as illustrated (preferably more than two such receivers are

utilized in such embodiments) are also narrow fiber optics. Other receiver fiber optics may be wide numerical aperture fiber optics (e.g., receivers such as receivers 458 of FIG. 20A). As illustrated, receiver fiber optics 472 of such embodiments are at an angle with respect to source fiber optic 470, with the numerical aperture of the receiver fiber optics selected such that, when the received intensity peaks as the probe is lowered to the surface, the receiver fiber optics' acceptance cones intersect with the entire circular area illuminated by the source fiber optic, or at least with a substantial portion of the area illuminated by the source. Thus, the receivers generally are measuring the same central spot illuminated by the source fiber optic.

[0174] A particular aspect of such embodiments is that a specular excluded probe/measurement technique may be provided. In general, the spectrally reflected light is not incident upon the receiver fiber optics, and thus the probe is only sensitive to diffuse light. Such embodiments may be useful for coupling reflected light to a multi-band spectrometer (such as described previously) or to more wide band sensors. Additionally, such embodiments may be useful as a part of a probe/measurement technique utilizing both specular included and specular excluded sensors. An illustrative arrangement utilizing such an arrangement is shown in FIG. 23B. In FIG. 23B, element 470 may consist of a source fiber optic, or alternatively may consist of all or part of the elements shown in cross-section in FIG. 20A or 20B. Still alternatively, non-parallel receiver fiber optics 472 may be parallel along their length but have a machined, polished, or other finished or other bent surface on the end thereof in order to exclude all, or a substantial or significant portion, of the specularly reflected light. In other embodiments, receiver fiber optics 472 may contain optical elements which exclude specularly reflected light. An additional aspect of embodiments of the present invention is that they may be more fully integrated with a camera. Referring now to FIGS. 24 to 26, various of such embodiments will be described for illustrative purposes. In such embodiments, optical characteristic measurement implements such as previously described may be more closely integrated with a camera, including common chassis 480, common cord or cable 482, and common probe 484. In one such alternative preferred embodiment, camera optics 486 are positioned adjacent to spectrometer optics 488 near the end of probe 484, such as illustrated in FIG. 25. Spectrometer optics 488 may incorporate, for example, elements of color and other optical characteristics measuring embodiments described elsewhere herein, such as shown in FIGS. 1-3, 9-10B, 11-12, 16-17, 20A, 20B and 23A and 23B. In another embodiment, camera optics and lamp/light source 490 is positioned near the end of probe 484, around which are positioned a plurality of light receivers 492. Camera optics and lamp/light source 490 provide illumination and optics for the camera sensing element and a light source for making color/optical characteristics in accordance with techniques described elsewhere herein. It should be noted that light receivers 492 are shown as a single ring for illustrative purposes, although in other embodiments light receivers such as described elsewhere herein (such as in the above-listed embodiments including multiple rings/groups, etc.) may be utilized in an analogous manner. Principles of such camera optics generally are known in the borescope or endoscopes fields.

[0175] With respect to such embodiments, one instrument may be utilized for both camera uses and for quantifying the

optical properties of teeth. The camera may be utilized for showing patients the general state of the tooth, teeth or other dental health, or for measuring certain properties of teeth or dental structure such as size and esthetics or for color postureization as previously described. The optical characteristic measuring implement may then measure the optical properties of the teeth such as previously described herein. In certain embodiments, such as illustrated in FIGS. 25 and 26, a protective shield is placed over the camera for use in a conventional manner, and the protective shield is removed and a specialized tip is inserted into spectrometer optics 488 or over camera optics and lamp/light source 490 and light receivers 492 (such tips may be as discussed in connection with FIGS. 23A-23C, with a suitable securing mechanism) for infection control, thereby facilitating measuring and quantifying the optical properties. In other embodiments a common protective shield (preferably thin and tightly fitted, and optically transparent, such as are known for cameras) that covers both the camera portion and spectrometer portion are utilized.

[0176] Based on the foregoing embodiments, with which translucency and gloss may be measured or assessed, further aspects of the present invention will be described. As previously discussed, when light strikes an object, it may be reflected from the surface, absorbed by the bulk of the material, or it may penetrate into the material and either be emitted from the surface or pass entirely through the material (i.e., the result of translucency). Light reflected from the surface may be either reflected specularly (i.e., the angle of reflection equals the angle of incidence), or it may be reflected diffusely (i.e., light may be reflected at any angle). When light is reflected from a specular surface, the reflected light tends to be concentrated. When it is reflected from a diffuse surface, the light tends to be distributed over an entire solid hemisphere (assuming the surface is planar) (see, e.g., FIGS. 21-22B). Accordingly, if the receivers of such embodiments measure only diffusely reflected light, the light spectrum (integrated spectrum or gray scale) will be less than an instrument that measures both the specular and diffusely reflected light. Instruments that measure both the specular and diffuse components may be referred to as "specular included" instruments, while those that measure only the diffuse component may be referred to as "specular excluded."

[0177] An instrument that can distinguish and quantify the degree of gloss or the ratio of specular to diffusely reflected light, such as with embodiments previously described, may be utilized in accordance with the present invention to correct and/or normalize a measured color spectrum to that of a standardized surface of the same color, such as a purely diffuse or Lambertian surface. As will be apparent to one of skill in the art, this may be done, for example, by utilizing the gloss measurement to reduce the value or luminance of the color spectrum (the overall intensity of the spectrum) to that of the perfectly diffuse material.

[0178] A material that is translucent, on the other hand, tends to lower the intensity of the color spectrum of light reflected from the surface of the material. Thus, when measuring the color of a translucent material, the measured spectrum may appear darker than a similar colored material that is opaque. With translucency measurements made as previously described, such translucency measurements may be used to adjust the measured color spectrum to that of a

similar colored material that is opaque. As will be understood, in accordance with the present invention the measured color spectrum may be adjusted, corrected or normalized based on such gloss and/or translucency data, with the resulting data utilized, for example, for prosthesis preparation or other industrial utilization as described elsewhere herein.

[0179] Additional aspects of the present invention relating to the output of optical properties to a dental laboratory for prosthesis preparation will now be described. There are many methods for quantifying color, including CIELab notation, Munsell notation, shade tab values, etc. Typically, the color of a tooth is reported by a dentist to the lab in the form of a shade tab value. The nomenclature of the shade tab or its value is an arbitrary number assigned to a particular standardized shade guide. Dentists typically obtain the shade tabs from shade tab suppliers. The labs utilize the shade tab values in porcelain recipes to obtain the final color of the dental prosthesis.

[0180] Unfortunately, however, there are variances in the color of shade tabs, and there are variances in the color of batches of dental prosthesis ceramics or other materials. Thus, there are variances in the ceramics/material recipes to obtain a final color of a tooth resulting in a prosthesis that does not match the neighboring teeth.

[0181] In accordance with the present invention, such problems may be addressed as follows. A dental lab may receive a new batch of ceramic materials and produce a test batch of materials covering desired color, translucency and/or gloss range(s). The test materials may then be measured, with values assigned to the test materials. The values and associated color, translucency and gloss and other optical properties may then be saved and stored, including into the dental instruments that the lab services (such as by modem download). Thereafter, when a dentist measures the optical properties of a patient's tooth, the output values for the optical properties may be reported to the lab in a formula that is directly related, or more desirably correlated, to the materials that the lab will utilize in order to prepare the prosthesis. Additionally, such functionality may enable the use of "virtual shade guides" or tooth data for customizing or configuring the instrument for the particular application.

[0182] Still other aspects of the present invention will be described with reference to FIGS. 27 and 28, which illustrate a cordless embodiment of the present invention. Cordless unit 500 includes a housing on which is mounted display 502 for display of color/optical property data or status or other information. Keypad 504 is provided to input various commands or information. Unit 500 also may be provided with control switch 510 for initiating measurements or the like, along with speaker 512 for audio feedback (such as previously described), wireless infrared serial transceiver for wireless data transmission such as to an intelligent charging stand (as hereinafter described) and/or to a host computer or the like, battery compartment 516, serial port socket 518 (for conventional serial communications to an intelligent charging stand and/or host computer, and/or battery recharging port 520. Unit 500 includes probe 506, which in preferred embodiments may include removable tip 508 (such as previously described). Of course, unit 500 may contain elements of the various embodiments as previously described herein.

[0183] Charging stand 526 preferably includes socket/holder 532 for holding unit 500 while it is being recharged, and preferably includes a socket to connect to wired serial port 518, wireless IR serial transceiver 530, wired serial port 524 (such as an RS232 port) for connection to a host computer (such as previously described), power cable 522 for providing external power to the system, and lamps 528 showing the charging state of the battery and/or other status information or the like.

[0184] The system battery may be charged in charging stand 526 in a conventional manner. A charging indicator (such as lamps 528) may be used to provide an indication of the state of the internal battery. Unit 500 may be removed from the stand, and an optical measurement may be made by the dentist. If the dentist chooses, the optical measurement may be read from display 502, and a prescription may be handwritten or otherwise prepared by the dentist. Alternatively, the color/optical characteristics data may be transmitted by wireless IR transceiver 514 (or other cordless system such as RF) to a wireless transceiver, such as transceiver 530 of charging stand 526. The prescription may then be electronically created based upon the color/optical characteristics data. The electronic prescription may be sent from serial port 524 to a computer or modem or other communications channel to the dental laboratory.

[0185] With reference to FIG. 29, additional aspects of the present invention will be discussed.

[0186] As is known, certain objects consist of an inner, generally opaque layer, and an outer, generally translucent layer. As previously discussed, light that is incident on a certain object generally can be affected by the object in three ways. First, the light can be reflected from the outer surface of the object, either diffusely or specularly. Second, the light can be internally scattered and absorbed by the object structures. Third, the light can be internally scattered and transmitted through the object structures and re-emerge from the surface of the object. Traditionally, it was difficult, if not impossible, to distinguish light reflected from the surface of the object, whether specularly or diffusely, from light that has penetrated the object, been scattered internally and re-emitted from the object. In accordance with the present invention, however, a differentiation may be made between light that is reflected from the surface of the object and light that is internally scattered and re-emitted from the object.

[0187] As previously described, a critical height h_c occurs when a pair of fiber optics serve to illuminate a surface or object and receive light reflected from the surface or object. When the probe's distance from the object's surface is greater than the critical height h_c the receiver fiber optic is receiving light that is both reflected from the object's surface and light that is internally scattered and re-emitted by the object. When the distance of the probe is less than the critical height h_c , light that is reflected from the surface of the object no longer can be received by the received fiber optic. In general, the only light that can be accepted by the receiver fiber optic is light that has penetrated outer layer 540 and is re-emitted by the object.

[0188] Most of the internal light reflection and absorption within a certain object occurs at junction 542, which in general separates outer layer 540 from inner layer 544. In accordance with the present invention, an apparatus and method may be provided for quantifying optical properties

such sub-surface structures, such as the color of junction 542, with or without comparison with data previously taken in order to facilitate the assessment or prediction of such structures.

[0189] Critical height h_c of the fiber optic probe such as previously described is a function of the fiber's numerical aperture and the separation between the fibers. Thus, the critical height h_c of the probe can be optimized based on the particular application. In addition, a probe may be constructed with multiple rings of receive fiber optics and/or with multiple numerical aperture receiving fiber optics, thereby facilitating assessment, etc., of outer layer thickness, surface gloss, etc.

[0190] By utilizing multiple rings of receiver fiber optics, a measurement of the approximate thickness of the outer layer may be made based on a comparison of the peak intensity above the object surface and a measurement in contact with the object surface. A probe with multiple critical heights will give different intensity levels when in contact with the object surface, thereby producing data that may be indicative of the degree of internal scattering and outer thickness or, object morphology at the point of contact, etc.

[0191] Accordingly, in accordance with the present invention, the color or other optical characteristics of a sub-surface structure, such as junction 542 of an object, may be assessed or quantified in a manner that is in general independent of the optical characteristics of the surface of the object, and do so non-invasively, and do so in a manner that may also assess the thickness of the outer layer 540.

[0192] Additionally, and to emphasize the wide utility and variability of various of the inventive concepts and techniques disclosed herein, it should be apparent to those skilled in the art in view of the disclosures herein that the apparatus and methodology may be utilized to measure the optical properties of objects using other optical focusing and gathering elements, in addition to the fiber optics employed in preferred embodiments herein. For example, lenses or mirrors or other optical elements may also be utilized to construct both the light source element and the light receiver element. A flashlight or other commonly available light source, as particular examples, may be utilized as the light source element, and a common telescope with a photoreceiver may be utilized as the receiver element in a large scale embodiment of the invention. Such refinements utilizing teachings provided herein are expressly within the scope of the present invention.

[0193] As will be apparent to those skilled in the art, certain refinements may be made in accordance with the present invention. For example, a central light source fiber optic is utilized in certain preferred embodiments, but other light source arrangements (such as a plurality of light source fibers, etc.). In addition, lookup tables are utilized for various aspects of the present invention, but polynomial type calculations could similarly be employed. Thus, although various preferred embodiments of the present invention have been disclosed for illustrative purposes, those skilled in the art will appreciate that various modifications, additions and/or substitutions are possible without departing from the scope and spirit of the present invention as disclosed in the claims. In addition, while various embodiments utilize light principally in the visible light spectrum, the present inven-

tion is not necessarily limited to all or part of such visible light spectrum, and may include radiant energy not within such visible light spectrum.

[0194] With reference to FIG. 5A, the intensity measured by a single receiver fiber is shown as a function of time as a source fiber optic and a receiver fiber optic pair are moved into contact with an object and are moved away from the object. FIG. 5A illustrates the intensity as a function of time, however as will be apparent to one skilled in the art, the intensity detected by the receiver fiber can also be measured and plotted as a function of height. A given fiber optic pair of source and receiver fiber optics, perpendicular to a surface (or at least at a fixed angle relative to a surface) will exhibit a certain intensity vs. height relationship. That relationship generally is consistent for certain materials of consistent gloss, color and translucency. The mathematical intensity vs. height relationship for certain source and receiver fiber optic pairs can be calculated or measured and stored as a look up table value or as a polynomial or other mathematical relationship. What is important to note is that there is an intensity peak that is a function of the gloss, translucency and color of the object being measured. For similar materials, the intensity value at a given height varies dependent upon color, although the shape of the intensity vs. height curve is largely independent of color. Thus, as will be apparent to one skilled in the art, the present invention may also serve as a proximity sensor, determining height from the intensity measurements. The instrument is calibrated by moving it towards the object until the peaking intensity is detected. While the instrument moves towards the object, the light intensities are rapidly measured and saved in memory such as RAM 10 shown in FIG. 1. From the value of the measured peaking intensity (utilized to normalize the intensity vs. height relationship of the fiber pair) the proximity sensor can be calibrated. Thereafter, the present invention may be utilized to measure the height of the fiber optic pair from the surface of the object without contacting the object.

[0195] The present invention may find application in a wide range of industrial activities. Certain applications of the present invention include, but are not limited to, measuring the optical properties of teeth and utilizing the measurements as part of a patient data base and utilizing the measurements for dental prosthesis preparation.

[0196] Another application of the present invention is its use in dermatology in quantifying the optical properties including color of skin and other tissues and saving the measurements as part of a patient data base record and utilizing the measurements made over a period of time for diagnostic purposes.

[0197] Yet another application of the present invention is in the food preparation industry where the color and other optical properties of certain foods that are affected by the preparation process are measured and monitored with the disclosed invention and are utilized to determine whether or not the food meets certain acceptance criteria and where the measurements may be also utilized as part of a control and feed back process whereby the food is further processed until it is either accepted or rejected. Similarly, in automated food processing, such as for vegetables or fruit, measurements may be taken and an assessment or prediction of the condition of the vegetable or fruit made, such as ripeness.

[0198] Yet another application of the present invention is to measure the color and optical properties of objects newly painted as part of a control process. For example, paint may be applied to the object, with the object then measured to determine if a suitable amount or type of paint has been applied, perhaps with the process repeated until a measurement corresponding to a desired surface condition is obtained, etc.

[0199] Yet another application of the present invention is to measure the optical properties of newly painted objects over a period of time to discern if the paint has cured or dried. Similarly, such an object may be measured to determine if additional gloss coatings, surface texture factors or fluorescence factors, etc., should be added to achieve a more optimum or desired object.

[0200] Yet another application of the present invention is in an industrial or other control system, where items are color coded or have color or gloss or translucency or combinations of optical properties that identify the objects and where the optical properties are measured utilizing the disclosed invention and are sorted according to their optical properties. In general, the present invention may be utilized to measure the optical properties of objects in an industrial process flow, and then compare such measurements with previously stored data in order to sort, categorize, or control the direction of movement of the object in the industrial process.

[0201] Yet another application of the present invention is to place color coded or gloss coated or translucent tags or stickers on objects that serve as inventory control or routing control or other types of identification of objects in industrial processes.

[0202] Yet another application of the present invention is part of the printing process to measure and control the color or other optical properties of inks or dies imprinted on materials. In such embodiments, implements as described herein may be integrated into the printer or printing equipment, or used as a separate implement.

[0203] Yet another application of the present invention is part of the photographic process to measure, monitor and control the optical properties of the photographic process. In such embodiments, implements as described herein may be integrated into the camera or other photographic instrument, or used as a separate implement.

[0204] Yet another application of the present invention is to measure the distance to the surface of objects without being placed into contact with the object.

[0205] The present invention may be used in an industrial process in which coatings or material are added to or removed from an object. The object may be measured, and coatings or materials added or removed, with the object re-measured and the process repeated until a desired object or other acceptance criteria are satisfied. In such processes, comparisons with previously stored data may be used to assess whether the desired object is obtained or the acceptance criteria satisfied, etc.

[0206] In yet another application, the present invention is utilized in the restoration of paintings or other painted objects, such as art works, automobiles or other objects for which all or part may need to be painted, with the applied

paint matching certain existing paint or other criteria. The present invention may be used to characterize whether paint to be applied will match the existing paint, etc. In such processes, comparisons with previously stored data may be used to assess whether the desired paint match will be obtained, etc.

[0207] In general, the present invention may find application in any industrial process in which an object or material may be measured for surface and/or subsurface optical characteristics, with the condition or status of such object or material assessed or predicted based on such measurements, possibly including comparisons with previously stored data as previously described, etc. Additionally, and to emphasize the wide utility and variability of various of the inventive concepts and techniques disclosed herein, it should be apparent to those skilled in the art in view of the disclosures herein that the apparatus and methodology may be utilized to measure the optical properties of objects using other optical focusing and gathering elements, in addition to the fiber optics employed in preferred embodiments herein. For example, lenses or mirrors or other optical elements may also be utilized to construct both the light source element and the light receiver element. A flashlight or other commonly available light source, as particular examples, may be utilized as the light source element, and a common telescope with a photoreceiver may be utilized as the receiver element in a large scale embodiment of the invention. Such refinements utilizing teachings provided herein are expressly within the scope of the present invention.

[0208] In addition to the foregoing embodiments, features, applications and uses, other embodiments and refinements in accordance with the present invention will now be described. As with prior descriptions, descriptions to follow are without being bound by any particular theory, with the description provided for illustrative purposes.

[0209] A variety of devices may be used to measure and quantify the intensity of light, including, for example, photodiodes, charge coupled devices, silicon photo detectors, photomultiplier tubes and the like. In certain applications it is desirable to measure light intensity over a broad band of light frequencies such as over the entire visible band. In other applications it is desirable to measure light intensities over narrow bands such as in spectroscopy applications. In yet other applications it is desirable to measure high light intensities such as in photographic light meters. In still other applications it is desirable to measure low light intensities such as in abridged spectrometers. Typically when measuring low light intensities, long sampling periods of the order of one second or longer are required.

[0210] In accordance with other aspects of the present invention, a method and apparatus are disclosed that may be used to measure multiple light inputs rapidly. Such an embodiment preferably utilizes a photodiode array, such as the TSL230 manufactured by Texas Instruments, Inc., and a gate array manufactured by Altera Corporation or Xilinx, Inc. In certain applications, such an embodiment may be utilized to measure broad band visible and infra-red light. In other applications, such an embodiment may be utilized as an abridged spectrometer in which each photodiode array has a notch filter, such as an interference filter, positioned above the light sensor.

[0211] The TSL230 consists of 100 silicon photodiodes arranged in a square 10 by 10 array. The 100 photodiodes

serve as an input to an integrator that produces an output signal of a frequency proportional to the intensity of light incident upon the array. The TSL230 has scale and sensitivity inputs allowing the sensitivity and scale to each be varied by a factor of 100, for a net range of 10^4 . The output frequency can vary from a maximum of approximately 300 k Hz (sensor is saturated) to sub Hz ranges. Thus, the sensor can detect light inputs ranging over seven orders of magnitude by varying the sensitivity and/or scale of the sensor and can detect light ranges of over five orders of magnitude at a given setting.

[0212] In spectroscopy applications for such embodiments, each sensor is mounted with an optical filter such as an interference filter. As is known in the art, interference filters have high out-of-band rejection and high in-band transmission, and may be constructed with very narrow band pass properties. As an example, interference filters may be constructed with band pass ranges of 20 nanometers or less. In accordance with certain aspects of the present invention, an abridged-type spectrometer may be constructed with TSL230 (or similar) sensors and interference filters that is suitable for reflectivity or transmission spectrographic applications such as measuring the color of objects. In color determination applications it is not necessary to detect "line" spectra, but it often is desirable to have high gray scale resolution, e.g., to be able to resolve the light intensity to 1 part in 1000 or greater.

[0213] Instruments and methods for measuring the optical properties of materials and objects have been previously described. Such an instrument may consist of a probe and an abridged spectrometer. The probe may be moved into contact or near contact with the surface of the material or object (by movement of the probe or material/object, etc.), and the spectrum of the light received by the probe was analyzed as the probe was moved towards the surface. Since the probe was not stationary, preferably numerous measurements are taken in succession, with the spectra dynamically taken and/or analyzed as the probe relatively moves in proximity with the object.

[0214] One difficulty that results from narrowing the band width of notch or interference filters is that such narrowing reduces the light intensity incident upon each sensor. Thus, to measure low light levels, long sampling times typically are required. In the case of the TSL230 sensor, as the light level decreases, the output frequency of the device decreases. Thus, if it is desired to make 200 samples per second with an abridged spectrometer constructed with notch filters and TSL230s, one needs enough light to cause the TSL230 output to oscillate at a rate of at least 200 Hz. Since the maximum range of the sensor is approximately 300 k Hz, the maximum dynamic range of the sensor is reduced to $(300 \text{ k Hz})/(200 \text{ Hz})$ or roughly 1.5×10^3 . If the light inputs are low, then the dynamic range is reduced still further.

[0215] FIG. 30 illustrates an abridged visible light range spectrometer in accordance with another embodiment of the present invention. This embodiment utilizes TSL230 sensors 616, a light source or lamp 604, preferably a hot mirror that reflects IR light with wavelengths above 700 nanometers (not expressly shown in FIG. 30), fiber optic cable assembly consisting of one or more sources (illustrated by light path 608) providing light to object 606, and one or more receivers

(illustrated by light path 618) receiving light from object 606, gate array 602 such as an Altera FLEX 10K30™ (believed to be a trademark of Altera Corporation), which is coupled to computer 600 and receives signal inputs from sensors 616 over bus 620. In one preferred embodiment up to fifteen or more TSL230 sensors are utilized. Each TSL230 sensor 616 has an interference filter 614 positioned above the sensor, with each filter preferably having a nominal bandwidth of 20 nanometers (or other bandwidth suitable for the particular application). Sensors 616 also preferably receive a small and controlled amount of light (light path 610) directly from light source 604, preferably after IR filtering. The light source input to sensors 616 serves to bias sensors 616 to produce an output of at least 200 Hz when no light is input to sensors 616 from filters 614. Thus, sensors 616 will always produce an output signal frequency greater than or equal to the sampling frequency of the system. When input light intensities are small, the frequency change is small, and when the light input is large, the frequency change will be large. The scale and sensitivity of sensors 616 are set (by gate array 602 over control bus 612, which may be under control of computer 600) to detect the entire range of light input values. In most cases, particularly in object color determination, the maximum amount of light input into any one of sensors 616 is determined by light source 604 and filters 614 and can be appropriately controlled.

[0216] Gate array 602 serves to measure the output frequency and period of each of sensors 616 independently. This may be done by detecting whenever an output changes and both counting the number of changes per sampling period and storing the value of a high speed counter in a first register the first time an output changes, and storing the value in a second register for each subsequent change. The second register will thus hold the final value of the timer. Both high to low and low to high transitions preferably are detected. The output frequency (f) of each sensor is thus:

$$f = \frac{(N - 1)}{(P_h - P_l)} \quad 1)$$

where:

[0217] N =Number of transitions in sample period;

[0218] P_l =Initial timer count; and

[0219] P_h =Final timer count.

[0220] The internal high speed timer is reset at the start of each sampling period ensuring that the condition $P_h > P_l$ is always true.

[0221] The precision of a system in accordance with such an embodiment may be determined by the system timer clock frequency. If P_r is the desired precision and S_r is the sampling rate, then the frequency of the timer clock is:

$$f_t = P_r \cdot S_r \quad 2)$$

For example, for a sampling rate of 200 and a precision of 2^{16} , the timer clock frequency is 200×2^{16} or 13 MHz.

[0222] If the input light intensities are high, N will be a large number. If the input light intensities are low, N will be small (but always greater than 2, with proper light biasing). In either case, however, $P_h - P_l$ will be a large number and

will always be on the order of $\frac{1}{2}$ the precision of the system. Thus, in accordance with such embodiments, the theoretical precision to which the light intensities can be measured may be the same for all sensors, independent of light input intensity. If one sensor has an output range of 200 to 205 Hz (very low light input), the intensities of light received by this sensor may be measured to about the same precision as a sensor with 10,000 times more light input (range of 200 to 50,200 Hz). This aspect of such embodiments is very unlike certain conventional light sensors, such as those utilizing ADCs, analog multiplexers and sample and hold amplifiers, where the precision of the system is limited to the number of bits of the ADC available over the input range. To provide for the wide input range in a system with an ADC, a variable gain sample and hold amplifier typically is required. It is also difficult for an ADC to sample to 16 bits accurately.

[0223] With such embodiments of the present invention, the absolute accuracy generally is limited by the stability of the lamp and electrical noise, both of which may be reduced and in general are minimal because of the simplicity of the design and the few components required on a circuit card. A gate array, which may be field programmable or the like, typically may readily accommodate 20 or more TSL230 sensors and also provide for an interface to a computer, microprocessor or microcontroller utilizing the light data. It also should be noted that, instead of a gate array, such embodiments may be implemented with high speed RISC processors or by DSPs or other processing elements.

[0224] It should be noted that the use of light biasing, and other aspects thereof, also are described elsewhere herein.

[0225] In addition to the foregoing embodiments, features, applications and uses, still other embodiments and refinements in accordance with the present invention will now be described.

[0226] Certain objects and materials such as gems and teeth exhibit reflected light spectrums that are a function of incident light angle and reflected light angle. Such objects and materials are sometimes referred to as opalescent materials. In accordance with other embodiments of the present invention, instruments and methodologies may be provided for specifically measuring and/or quantifying the opalescent characteristics of objects and materials, in addition to characteristics such as color, gloss, translucency and surface texture, it being understood that previously described embodiments also may be used to capture spectral and other data (such as a plurality of spectrums), which can be compared and/or processed to quantify such opalescent materials.

[0227] Such a further embodiment of the present invention is illustrated in FIG. 31. In accordance with this embodiment, light source 638 provides light coupled through a light path (preferably light source fiber 636) to probe 630 through optical cable 632. Light received by the probe (i.e., returned from the object or material being evaluated) is coupled to spectrometer/light sensors 640 through a suitable light path (preferably one or more light receiver fibers from optical cable 632). Computer 642 is coupled to spectrometer/light sensors 640 by way of control/data bus 648. Computer 642 also is coupled to light source 638 by way of control line(s) 646, which preferably control the on/off condition of light source 638, and optionally may provide other control information, analog or digital signal levels, etc., to light source

638 as may be desired to optimally control the particular light chosen for light source 638, and its particular characteristics, and for the particular application. Light from light source 638 optionally may be coupled to spectrometer/light sensors 640 by light path 644, such as for purposes of providing light bias (if required or desired for the particular spectrometer chosen), or for monitoring the characteristics of light source 638 (such as drift, temperature effects and the like).

[0228] Computer 642 may be a conventional computer such as a PC or microcontroller or other processing device, and preferably is coupled to a user interface (e.g., display, control switches, keyboard, etc.), which is generically illustrated in FIG. 31 by interface 652. Optionally, computer 642 is coupled to other computing devices, such as may be used for data processing, manipulation, storage or further display, through interface 650. Computer 642 preferably includes the typical components such as (but not limited to) a CPU, random access or other memory, non-volatile memory/storage for storing program code, and may include interfaces for the user such as display, audio generators, keyboard or keypad or touch screen or mouse or other user input device (which may be through interface 652), and optionally interfaces to other computers such as parallel or serial interfaces (which may be through interface 650). Computer 642 interfaces to spectrometer/light sensors 640 for control of the spectrometer and overall system and to receive light intensity and light spectrum data from spectrometer/light sensors 640. In a preferred embodiment, control/data bus 648 for interfacing to spectrometer/light sensors 640 is a standard 25 pin bi-directional parallel port. In certain embodiments, computer 642 may be separate, standalone and/or detachable from spectrometer/light sensors 640 and may be a conventional laptop, notebook or other portable or handheld-type personal computer. In other embodiments, computer 642 may be an integral part of the system contained in one or more enclosure(s), and may be an embedded personal computer or other type of integrated computer. Purposes of computer 642 preferably include controlling light source 638 and spectrometer/light sensors 640, receiving light intensity and spectral or other data output from spectrometer/light sensors 640, analyzing received or other data and determining the optical properties of the object or material, and displaying or outputting data to a user or other computing device or data gathering system.

[0229] In a preferred embodiment, the output end of probe 630 may be constructed as illustrated in FIG. 32. Numerous other probe configurations, including probe configurations as described elsewhere herein, may be used in such embodiments. In accordance with such preferred embodiments, optical characteristics determination systems/methods may be obtained that provide for a broader range of measurement parameters, and, in certain applications, may be easier to construct. Probe cross section 656 includes central fiber optic 658, which is preferably surrounded by six perimeter fiber optics 660 and 662. Central fiber optic 658 is supplied by light from the light source (such as light source 638). Six perimeter fiber optics 660 and 662 are light receivers and pass to spectrometer/light sensors 640. In one preferred embodiment, all seven fiber optics have the same numerical aperture (NA); however, as disclosed below, the numerical aperture of the light source and consequently the source fiber optic preferably can be varied. Also, in certain embodiments

the received cone of light from certain of the receiver fiber optics is also controlled and varied to effectively vary the NA of certain receivers.

[0230] As illustrated in FIG. 32, central fiber optic 658 (S) serves as the light source. Fiber optics 660 labeled 1,3,5 preferably are “wide band” fibers and pass to light sensors (preferably within spectrometer/light sensors 640) that measure light intensity over an entire spectral range. The other three light receivers 662 labeled 2,4,6 preferably are “dual” receivers and pass to both a spectrometer and to “wide band” light sensors (also preferably within spectrometer/light sensors 640). As previously described, the probe in conjunction with a spectrometer, computer, light source and “wide band” light receivers can be used to measure the color and translucency and surface properties of teeth and other materials. Also as previously described, the probe with a combination of NA “wide band” receiver fiber optics can additionally be utilized to measure the gloss or the degree of specular versus diffuse light received from a surface.

[0231] FIG. 33A is a diagram of a preferred embodiment of spectrometer/light sensors 640. In this embodiment, certain optical fibers from the probe are coupled to wide band light sensors (such sensors, which may include TSL230 sensors and optics and/or filters as described elsewhere herein are illustrated as sensors 676 in FIG. 33A), while other of the optical fibers are coupled to both a spectrometer, in order to spectrally measure the light received by the probe, and to wide band light sensors. Fibers 660 (1,3,5) preferably are coupled to three wide band light sensors (light path 682 of FIG. 33A). Preferably, the light receiving/sensing elements are Texas Instruments TSL230s, although they may also be photo diodes, CCDs or other light sensors. Fibers 660 (1,3,5) preferably are masked by iris 694 to reduce the size of the cone of light produced by the fiber as illustrated in FIG. 34. Mask or iris 694 serves to limit the NA of the receiver by allowing only light rays with a maximum angle of α to be received by the receiver light sensor.

If:

[0232] h =height of end of fiber to iris

[0233] r =radius of opening of the iris

[0234] a =radius of the fiber

1) then:

$$\alpha = \text{Tan}^{-1}\left(\frac{r+a}{h}\right)$$

Hence, the effective NA of the receiver fiber optic can be reduced and controlled with iris 694. By utilizing a variable iris or an iris that is controlled with a servo such as those utilized in conventional cameras, the NA of the receiver fiber optic can be controlled by the system and can be varied to best match the object or material being measured. Referring again to FIG. 34, exemplary receiver fiber 690 provides light to exemplary light sensor 676 through iris 694. Light rays such as light rays 696A of a certain limited angle pass through iris 694, while other light rays within the acceptance angle of fiber 690 (the outer limit of the acceptance angle is illustrated by dashed line 696 in FIG. 34) but not within the limited angular range allowed by iris 694 are blocked,

thereby enabling iris 694 to effectively emulate having a reduced or variable NA light receiver.

[0235] Referring again to FIG. 33A, light source 638 may be coupled to certain of sensors 676 through light path 674. Light bias, such as previously described, may be provided from the light source, or alternatively, from separately provided LED 680, which may couple light to certain of sensors 676 for providing controllable light bias to sensors 676 through light conduit 678. Control of LED 680 for providing controllable light bias to certain of sensors 676, etc., is described elsewhere herein. Light from fibers 662 preferably are coupled (through light path 684 in FIG. 33A) to one or more diffusing cavities 686 (described in more detail elsewhere herein), outputs of which are coupled to certain of sensors 676 through light paths/conduits 688 as illustrated. Control of sensors 676, and data output from sensors 676, preferably is achieved by way of gate array 670, which may be coupled to a computing device by way of interface 668 (the use of gate array or similar processing element and the use of such a computer device are described elsewhere herein).

[0236] The use of diffusing cavities 686 in such embodiments will now be further described. As illustrated, certain of the light receivers 662 (2,4,6) may be coupled to one or more diffusing cavities 686 through light path 684, which may serve to split the light receivers into, for example, six (or more or fewer) fiber optics with a diffusing cavity as illustrated in FIGS. 35A, 35B, and 35C. One of light receivers 662 is the central fiber in diffusing cavity 686 and is surrounded by six fiber optics 702 as part of fiber optic bundle 698. Diffusing cavity 686 serves to remove any radial or angular light distribution patterns that may be present in receiver fiber optic 662, and also serves to more evenly illuminate the six surrounding fiber optics. Thus, light receivers 662 (2,4,6) illustrated in FIG. 32 may each be split into six (or a different number) fibers resulting in eighteen receivers. Three of the eighteen fibers, one per diffusing cavity, preferably pass to wide band sensors which may have iris 694 (see FIG. 34). The other fifteen fibers preferably pass to a spectrometer system (such as part of spectrometer/light sensors 640, which may consist of a plurality of sensors 676, such as previously described). For the visible band, fifteen fiber optics and interference notch filters preferably are used to provide a spectral resolution of:

$$\frac{700 \text{ nm} - 400 \text{ nm}}{15} = 20 \text{ nm.} \tag{2}$$

A greater or lesser number of fibers and filters may be utilized in accordance with such embodiments in order to increase or decrease the spectral resolution of the system/spectrometer.

[0237] In FIGS. 33B and 35C, an alternate embodiment of the present invention utilizing a different arrangement of diffusing cavity 686 will now be described. In such embodiments, three “dual band” receivers 662 are all positioned in common fiber optic bundle 698 and one diffusing cavity 686 is utilized. Fiber optic bundle 698 preferably contains three receiver fibers 662 and fifteen additional fibers 703 for the spectrometer system, although greater or fewer fibers may be utilized in other arrangements depending on the number

of color sensors in the system. In certain embodiments, fifteen fiber optics **703** in the bundle may be of different diameters to increase the efficiency of diffusing cavity **686** and the cross sectional packing arrangement of the optical fibers in fiber optic bundle **698**. As an example of such preferred fiber bundle arrangements in accordance with such embodiments, larger diameter fibers may be utilized for the color filters in the blue range of the visible spectrum, where the light intensity from a tungsten-halogen lamp source **638** is significantly less than in the red region of the visible spectrum.

[0238] As described elsewhere herein, a spectrometer system may be constructed of Texas Instruments TSL230 light sensors, interference filters, light biasing elements and a gate array such as an Altera FLEX 10K30 in order to control the light sensors, interface to a computer via a parallel or other interface and to measure the frequency and period of the light sensors simultaneously at a high rate in order to accurately and rapidly measure light spectrums and light intensities. Although such spectrometer systems are used in preferred embodiments, other spectrometers such as those utilizing, for example, CCDs with diffraction gratings are utilized in other embodiments.

[0239] FIG. 36 illustrates a further refinement of aspects of a spectrometer-type system in accordance with the present invention. A fiber optic, such as one of the fifteen fibers from three diffusing cavities as described earlier, preferably pass to light sensor **710** (which may be a TSL230 light sensor, as previously described) through interference filter **708**. Interference filters such as interference filter **708** serve as notch filters passing light over a narrow bandwidth and rejecting light that is out of band. The bandwidth of the light transmitted through the filter, however, is dependent upon the angle of incidence of the light on the filter, and in general is broadened as the angle of incidence increases. Since fiber optics produce a cone of light, it has been determined that it is desirable to collimate the cone to reduce such bandwidth spreading. As illustrated in FIG. 36, the cone of light produced by exemplary fiber optic **704** (illustrated by lines **712A**) preferably is collimated with first aspheric lens (or fresnel lens) **706A** (illustrated by lines **712B**) prior to entering interference filter **708**. Light emitted from filter **708** (illustrated by lines **712C**) is "gathered" by second aspheric lens (or fresnel lens) **706B** to concentrate (illustrated by lines **712D**) as much light as possible on light sensor **710**. In accordance with such embodiments, filters, particularly interference-type filters, may more optimally be utilized in a manner to reduce such bandwidth spreading or other undesirable effects.

[0240] Referring again to FIG. 33A (the discussion also is generally applicable to FIG. 33B), light biasing as previously described will be discussed in greater detail. As previously described, in order to rapidly sample TSL230-type sensors, the sensors may require light biasing. Without light biasing, depending upon the light intensity presented to the particular sensors, a TSL230 sensor may not produce an output change pair of transitions (e.g., high to low and low to high transitions, or low to high and high to low transitions) during the sampling period, hence a light intensity measurement may not be possible for that sensor. In preferred embodiments, the sensing system detects both high to low and low to high transitions and requires at minimum two transitions to make a measurement. In other words, such

system measures half periods. For example, assume that as the light intensity on a particular TSL230 decreases such that its output frequency decreases from 201 Hz to 199 Hz. At 201 Hz, the output of the TSL230 transitions with a period of $\frac{1}{201}$ sec or every 4.975 ms. At 199 Hz, the output transition period is $\frac{1}{199}$ sec or 5.025 ms. If the sampling rate is 200 samples per second, then the sampling period is 5.00 ms. Thus, if the TSL230 transitions every 4.975 ms, the sensing system will always detect either two or three transitions and will always be able to make an intensity measurement. At 199 Hz, however, the detection circuitry will detect either one or two transitions. As a result, during certain sampling intervals, measurements are possible, while during other intervals measurements are not possible, thereby resulting in measurement discontinuities even though the light intensity has not changed.

[0241] It is desirable to measure light over a broad range of intensity values at high rates including very low light intensities. By utilizing light biasing of the TSL230 sensors as illustrated in FIG. 33A, the minimal output frequency of the TSL230s can be controlled. The minimal light value preferably is measured as part of a normalization or calibration procedure as follows.

[0242] 1. The light bias is turned on and allowed to stabilize.

[0243] 2. The probe is placed into a black enclosure. A "black level" intensity measurement I_b is made and recorded for each sensor, preferably in a simultaneous manner.

[0244] 3. The light source is turned on and allowed to stabilize. A "white level" intensity measurement I_w is made and recorded for each sensor, again preferably in a simultaneous manner, on a "white" standard such as barium sulfide or on "Spectralon," believed to be a trademarked product of Labsphere, Inc. The actual intensities measured by all sensors will vary from the standard values I_s . Typically in color measurements the standard value I_s is nominally "100%."

[0245] 4. Subsequent light measurements may be normalized by subtracting the "black level" intensity and by adjusting the gain from the white level measurement resulting in a normalized intensity I_N for each sensor as follows:

$$I_N = \frac{I_s}{I_w - I_b}(I - I_b) \quad 3)$$

where I =Intensity measurement and I_N is the normalized or calibrated intensity measurement. It should be noted that in such preferred embodiments the normalization is made for each light sensor, and independent "black level" and "white level" intensities are saved for each sensor.

[0246] In certain situations, a long time may be required for the light source and for the light bias source to stabilize. In other situations, the light source and bias source may drift. In preferred embodiments, the light source is a 18 W, 3300K halogen stabilized tungsten filament lamp manufactured by Welch Allyn, Inc. The light bias preferably is provided by a high intensity LED and a fiber optic light guide or conduit

(see LED 680 and light conduit 678 of FIG. 33A) that passes to each biased sensor of sensors 676. The intensity of LED 680 preferably is controlled and varied with high frequency pulse width modulation, or by analog constant current controllers. By controlling the intensity of bias LED 680, the bias light level can be varied to best match the sensor sampling rate.

[0247] Preferably, one sensor, such as a TSL230 sensor, is provided to measure the intensity of LED 680 and to correct for intensity variations of the LED light biasing system. Since LED 680 is monochromatic, one sensor typically is sufficient to track and correct for bias LED intensity drift. The LED bias intensity preferably is measured and recorded when the “black level” measurement is made. For each subsequent light intensity measurement, the black level for each sensor is corrected for LED drift as follows:

$$I_b(\text{Corrected}) = I_b \frac{I(\text{BiasSensor})}{I_b(\text{BiasSensor})} \quad 4)$$

where: I(BiasSensor) is the intensity measured by the bias sensor, I_b(BiasSensor) is the “black level” intensity measured by the bias sensor, I_b is the “black level” intensity measured by a light sensor (other than the bias sensor) and I_b(Corrected) is the adjusted bias used in equation 4) above.

[0248] Light source drift preferably is measured by a plurality of light sensors. Since the light source is polychromatic light, its spectrum may also drift. It is understood that tungsten filament lamps produce spectrums that are very nearly approximated by the spectrums of black body radiators and can be represented by the Planck law for black body radiators.

$$I(\lambda) = \left(\frac{2 \cdot \pi \cdot h \cdot c}{\lambda^3} \right) \left(\frac{1}{e^{\frac{hc}{\lambda kT}} - 1} \right) \quad 5)$$

The only variable affecting the intensity of a black body radiator at any wavelength within the visible band is the temperature (T) of the source. Thus, a single narrow band light sensor may be utilized to detect temperature variations of such a source. Additional factors, however, may affect the spectral output of the lamp, such as depositing of the filament on the lamp envelope or adjusting the spectrum of the lamp as described below. In the preferred embodiment, for more accurate spectral corrections and intensity variations of the lamp, additional narrow band filters are utilized. In certain of such preferred embodiments, three band pass filters and sensors are utilized to measure the spectral shift and intensity of the lamp in a continuous manner, and such filters and sensors preferably are further utilized to correct for lamp spectral and intensity drift.

[0249] FIG. 37 illustrates a preferred embodiment of a light source used in preferred embodiments of the present invention. Such a light source preferably consists of halogen tungsten filament lamp 724, with a lens molded into the envelope of the lamp that produces a concentrated light pattern on an axis parallel to the body of lamp 724. The use of such a lens in lamp 724 is to concentrate the light output

and to reduce the shadowing of the lamp filament that may result from lamps with reflectors. Hot mirror 722, which preferably is a “0° hot mirror,” reduces the intensity of IR light input into the system. In certain embodiments, the hot mirror may also contain color correction properties, for example, reducing light intensity for longer (red) wavelengths more than for shorter (blue) wavelengths. Light output from lamp 724 passes through hot mirror 722 preferably to tapered glass rod 720. The end of glass rod 720 nearest lamp 724 preferably has a diameter nominally the diameter of the envelope of lamp 724. The other end of glass rod 720 preferably is nominally 4 mm, or up to four times or more the diameter of source fiber optic 714.

[0250] Glass rod 720 serves a number of purposes. First, glass rod 720 serves as a heat shield for fiber optic 714 by allowing fiber optic 714 to be displaced from lamp 724, with fiber optic 714 being thermally insulated from lamp 724 by the existence of glass rod 720. Second, glass rod 720 serves to concentrate the light over a smaller area near fiber optic 714 and to broaden the angular distribution of light emerging from the narrow end to provide a distributed light pattern that can uniformly “fill” the NA of source fiber optic 714. Without tapered glass rod 720, the angular distribution pattern of light emerging from lamp 724 may not entirely or evenly fill the acceptance cone of source fiber optic 714. To ensure that source fiber optic 714 is desirably filled with light without an implement such as glass rod 720 would require source fiber optic 714 to be very close to lamp 724, thereby creating a risk that source fiber optic 714 will overheat and possibly melt.

[0251] Between source fiber optic 714 and glass rod 720 preferably is iris 718. Iris 718 preferably is utilized to limit the angular range of light rays entering source fiber optic 714. When iris 718 is fully open, the entire acceptance cone of source fiber optic 714 may be filled. As iris 718 is closed, the cone of light incident upon source fiber optic 714 is reduced, and hence the angular distribution of light incident upon fiber optic 714 is reduced. As iris 718 is reduced further, it is possible to produce a nearly collimated beam of light incident upon fiber optic 714.

[0252] It is understood that a property of fiber optics whose ends are highly polished perpendicular to the axis of the fiber optic is that the angle of light incident on one end of the fiber optic is preserved as it exits the other end of the fiber optic. As is known to those skilled in the art, numerous technologies exist for polishing fiber optic cables. Thus, with a highly polished fiber optic, by varying the diameter of iris 718, the cone of light entering source fiber optic 714 can be controlled, and thus the cone of light emerging from source fiber optic 714 can be controlled.

[0253] In an alternate embodiment, iris 718 is replaced by disk 730, which preferably includes a pattern of holes positioned near its perimeter as illustrated in FIGS. 38A and 38B. Preferably, disk 730 is driven with stepping motor 738 through gear 736 and gear teeth 730A so that disk 730 may be rapidly moved to a desired position and held in a stable position in order to make a light measurement. Stepping motor 738 is controlled by a computer (such as described elsewhere herein; see, e.g., FIGS. 30 and 31), which controls disk 730 to rotate about axis 732 and stop in a desired and controllable position. Thus, such a computer in effect can

vary the NA of the light source synchronously to each measurement. The procedure preferably progresses as follows.

1. Rotate the disk to the desired aperture.
2. Pause to allow the disk to stabilize.
3. Measure one light sample.
4. Rotate the disk to the next desired aperture and repeat the process as required.

[0254] As illustrated FIG. 38B, the pattern of holes on disk 730 may be round or any other desired shape. Such apertures also may constitute a pattern of microscopic holes distributed to affect the light pattern of light or spectrum of light entering the source fiber. Additionally, the disk may contain filters or diffraction gratings or the like to affect the spectrum of the light entering the source fiber. Such holes or apertures also may consist of rings that produce cones of light where the light rays entering the fiber are distributed over a narrow or other desired range of angles. With the disk embodiment of FIGS. 38A and 38B, it is possible to control the light pattern of source fiber optic 714 effectively over a wide range of angles.

[0255] Referring again to FIG. 37, light conduit 716 passes light such as through light path 674 to sensors 676 (see, e.g., FIGS. 33A and 33B) for measuring the spectral properties of the lamp as described earlier. If the iris or aperture disk controlling the distribution of light entering source fiber optic 714 modifies the spectral properties of the light source, then the resulting spectrum can be adjusted as described earlier.

[0256] When a pair of fiber optics is utilized as described herein where one fiber serves as a light source and another fiber serves as a light receiver, the intensity of light received by the receiver fiber varies with the height of the pair above the surface of the object or material and also with the angle of the pair relative to the surface of the object or material. As described earlier, in certain preferred embodiments the angle of the probe relative to the surface may be detected by utilizing three or more fiber optic receivers having the same receiver NA. After normalization of the system, if the intensities of the three receiver fibers (such as fibers 660 (1,3,5) in FIG. 32) are the same, then this is an indication that the probe is perpendicular to the surface. If the intensities vary between the three sensors, then this is an indication that the probe is not perpendicular to the surface. As a general statement, this phenomenon occurs at all heights. In general, the intensity variation of the three fibers is dependent upon the geometry of the three fibers in the probe and is independent of the color of the material. Thus, as the probe is tilted towards fiber 1, for example, the intensities measured by sensors 3 and 5 will be nominally equal, but the intensity measured by fiber 1 will vary from fibers 3 and 5. As a result, the system can detect an angular shift towards fiber 1. In preferred embodiments, by comparing the intensity values of fiber 1 to fibers 3 and 5, a measurement of the angle can be made and the intensity of fibers 1, 3 and 5 can be corrected by a correction or gain factor to "adjust" its light measurement to compensate for the angular shift of the probe. It is thus possible with the probe arrangement illustrated in FIG. 32 to detect and measure angular changes.

[0257] Angular changes also will affect the intensities measured by the other fibers 662 (2,4,6). In a similar manner,

the difference between the "wide band" sensors in fibers 662 (2,4,6) can also be utilized to further quantify the angle of the probe and can be utilized to adjust the light intensity measurements. It should be noted, however, that the intensity shift due to angle of the probe affects the fibers differently. If sensors 662 (2,4,6) are utilized in the spectrometer illustrated in FIG. 33A, the intensity adjustment must be made independently for each fiber and for the set of six fibers emerging from diffusing cavity 686 illustrated in FIG. 35A. However, if one diffusing cavity 686 is utilized as illustrated in FIG. 33B, the angle correction applies to all sensors supplied by light paths 703 equally. With such an embodiment as illustrated in FIG. 33B, angle determination and/or correction may be made in a manner more desirable for some applications.

[0258] As the probe approaches the surface of an object or material (the probe may be moved towards the material or the material may be moved towards the probe), the source fiber illuminates the object/material. Some light may reflect from the surface of the object/material, and some light may penetrate the object/material (if it is translucent or has a translucent layer on its surface) and re-emerge from the material and may strike the receiver fiber optic. As described elsewhere herein, the intensity measured by the receiver exhibits a peaking phenomenon where the light intensity varies to a maximum value, and then falls until the probe is in contact with the object/material where it exhibits a minimum. If the object/material is opaque, then the light intensity at the minimum is essentially zero. If the object/material is highly translucent, then the intensity may be near the peaking intensity.

[0259] Based on such phenomena, in accordance with other aspects of the present invention, it is possible to quantify the height of the probe and to adjust for height variations of the probe near the peaking height by measuring the peaking height intensity of the "wide band" sensors and comparing the intensity value at other heights and adjusting the gain of all sensors by the ratio of the measured intensity to the peaking intensity. If I_p is the peak intensity of a wide band receiver, and I_m is the intensity measured when the probe is in contact with the material, and I is the intensity measured at a height less than the peaking height then the ratio:

$$G = \frac{I_p - I_m}{I - I_m} \quad 6)$$

is the gain adjustment factor. If the gain adjustment factor is applied to the spectrometer sensors, then the spectrum may be measured independent of height for a wide range of heights within the peaking height.

[0260] Reference should now be made to FIGS. 39A and 39B. As a fiber optic pair (e.g., source fiber optic 742 and receiver fiber optic 744) approach a material or object 746, material or object 746 is illuminated by source fiber optic 742 (see, e.g., lines 745 of FIG. 39A). The light emitted from source fiber optic 742 may be controlled as described elsewhere herein. Thus, source fiber optic 742 can be controlled so as to illuminate material or object 746 with nearly collimated light (small incident angles), or source fiber optic 742 can be controlled to illuminate material or

object **746** with wide incident angles, or with a pattern of angles or with different spectral properties. If source fiber optic **742** is illuminated with an aperture disk with a slit pattern as illustrated in FIG. **38B**, then source fiber optic **742** may be used to illuminate material or object **746** with a narrow singular range of angles.

[0261] Consider source fiber optic **742** and receiver fiber optic **744** with the same NA as illustrated in FIGS. **39A** and **39B**. The angular distribution of light provided by source fiber optic **742** is dependent upon the source fiber only (and the angle of the probe) and is independent of the height of the fiber from the material. If the probe is held substantially perpendicular to material or object **746**, the angular distribution of light is independent of height. The area illuminated by source fiber **742**, however, is height dependent and increases with increasing height. Receiver fiber optic **744** can only receive light that is within its acceptance angle, thus it can only detect light reflected from the surface that is reflected from the area of overlap of the two cones illustrated in FIGS. **39A** and **39B**.

[0262] FIG. **39A** illustrates the fiber pair at the peaking height, while FIG. **39B** illustrates the fiber pair at the critical height. At the critical height, the only light reflecting from the surface that can be received by receiver fiber **744** is the source ray **745** and the reflected ray **748** with angle of incidence equal to angle of reflection, or it can only detect "spectrally" reflected light. When the probe is at the peaking height, however, the reflected light rays that can be received by the receiver fiber vary over both a wider angle of incidence range and wider angle of reflection range. Thus, at the peaking height, the receiver is detecting a broad range of incident angle light rays and reflected angle light rays. By adjusting the spectrum for height shifts as described above and by detecting the angle of the probe relative to the surface of the material or object, the reflected or returned spectrum can be measured over a wide incident angular range and reflected angular range.

[0263] In general, for opaque surfaces, diffuse or specular, the height adjusted spectrum will appear constant as the probe approaches the material or object. In general, for opalescent materials or objects, i.e., materials with a translucent surface in which light rays may penetrate the material and be re-emitted, the height adjusted spectrum will shift as the probe approaches the material or object. In general, for translucent materials such as teeth or gem stones, the spectrum will further shift when the probe is less than the critical height and in contact or near contact with the material or object.

[0264] As a further refinement to certain aspect of the present invention, the iris illustrated in FIG. **37** or the aperture disk illustrated in FIGS. **38A** and **38B** may be utilized. In one such embodiment, the NA of source fiber optic **714** is held constant as the probe approaches the material or object, and light intensity and spectrum measurements are made and saved in a data queue as described earlier. When the probe is in contact with the material or object, the NA of source fiber optic **714** is changed (either from narrow to wide or from wide to narrow, depending upon the state of the first set of measurements), and spectral measurements are made as a function of source NA. The probe is then moved away from the material and light intensity and spectral measurements are made as the dis-

tance from the probe increases and as the probe passes through the peaking height. The spectral shift that occurs as a result of the variance of the source NA and height preferably is used to quantify the opalescence of the material or object.

[0265] In an alternate embodiment, the aperture disk illustrated in FIGS. **38A** and **38B** is rotated by stepping motor **738** synchronously to measuring the light and spectral data as the probe is moved into proximity to the material or object or into contact with the material or object. In another alternate embodiment, the probe is positioned at a fixed height from the material or in contact with the material or object and the NA of the source fiber is varied as light intensity and spectral data are measured. In yet another alternate embodiment, both the source and receiver fiber NAs are varied as described earlier, and the resulting spectra are utilized to quantify the optical properties of the material.

[0266] An alternative embodiment of the present invention for quantifying the degree of gloss of a material will now be described with reference to FIGS. **40A** and **40B**. FIGS. **40A** and **40B** illustrate source (**742**) and receiver (**744**) fiber pair positioned above a highly specular surface such as a mirror (FIG. **40A**) and above a diffuse surface (FIG. **40B**). The cone of light from source fiber optic **742** is illustrated by circle **742A**, and the acceptance cone of receiver fiber optic **744** is illustrated by circle **744A**, with the overlap illustrated by area **750**. On a specular surface, the only light that will be received by receiver fiber optic **744** are the light rays whose angle of reflection equal the angle of incidence, thus the only light rays striking the surface of receiver **744** are the light rays striking the small circular area the size of the diameter of the fiber optics as illustrated by circle **752** in FIG. **40A**. As long as receiver fiber optic **744** has an NA greater than source fiber optic **742**, all light incident upon receiver fiber optic **744** will be accepted. Thus, the angular distribution of received light rays in receiver fiber optic **744** is limited to a very narrow range and is dependent upon the height of the fiber optic pair from the surface.

[0267] Consider FIG. **40B**, which illustrates a fiber optic pair positioned above a diffuse surface. Any light ray incident upon the area of overlap of the two cones can be received by receiver fiber optic **744** (provided of course that it is incident upon the receiver fiber). Thus, for diffuse surfaces, the angular distribution of light rays received by receiver fiber optic **744** is also height dependent, but is greater than the angular distribution for a specular surface. In accordance with such embodiments of the present invention, such angular distribution variation may be used to quantify optical properties such as gloss for a particular material or object.

[0268] A detector in accordance with other embodiments of the present invention is illustrated in FIG. **41**, where single receiver fiber **758** is positioned above a radial distribution of sensors (illustrated by sensors **760A** and **760B**). Two or more sensors may be utilized, in one or two dimensions, although only two sensors are illustrated in FIG. **41** for discussion purposes. In the illustrated embodiment, one sensor (sensor **760B**) is positioned corresponding to the center of fiber **758** and measures angles near zero, and the other sensor (sensor **760A**) is positioned at approximately $\frac{1}{2}$ the acceptance angle of receiver fiber **758**. In alternate

embodiments, the sensors may be arranged or configured in a linear array such as a CCD, or a two dimensional sensor such as a video camera CCD or MOS sensor. In accordance with aspects of the present invention, by analyzing the intensity patterns of the sensors, the degree of gloss of the material may be measured and quantified.

[0269] As the probe is moved towards the material or object, the angular distribution of light received by receiver fiber 758 changes dependent upon the surface of the material or object as illustrated in FIGS. 42A and 42B. FIG. 42A illustrates the intensity pattern for the two sensors for a specular surface, and FIG. 42B shows the intensity pattern for a diffuse surface. Specular materials in general will tend to exhibit a peaking pattern where the peaking intensity of sensor 1 is much larger than the peaking intensity of sensor 2. For diffuse materials the peaking intensity of sensor 2 (wide angles) is closer to the peaking intensity of sensor 1. By quantifying the variation in peaking intensity the degree of gloss of the material can be additionally quantified. In addition, in alternative embodiments, the relative values of the sensors at a time when one or the other sensors is peaking are captured and further used to quantify the optical properties of the material or object.

[0270] In conjunction with various of the foregoing embodiments, a variety of optic fibers may be utilized, with smaller fibers being used to assess optical characteristics of smaller spots on the object or material under evaluation. In accordance with such aspects of the present invention and with various of the embodiments described herein, fibers of about 300 microns in diameter, and up to or less than about 1 millimeter in diameter, and from about 1 to 1.5 millimeters have been utilized, although fibers of other diameters also are utilized in other embodiments and applications of the present invention. With such fibers, the optical properties of the object or materials under evaluation may be determined with a spot size of about 300 microns, or alternatively about 1 millimeter, or about 1.5 millimeters, or from about 0.3 to 1 millimeters, or from about 1 to 1.5 millimeters. In accordance with such embodiments, optical properties of such a spot size, including spectral, translucence, opalescence, gloss, surface texture, fluorescence, Rayleigh scattering, etc., may be quantified or determined, including by determining a plurality of spectrums as the probe is directed towards or in contact or near contact with the object or material and possible changes in such spectrums, all with an instrument that is simply directed towards a single surface of the object or material under evaluation.

[0271] It also should be noted that, in accordance with various principles of the various embodiments of the present invention described herein, refinements may be made within the scope of the present invention. Variations of source/receiver combinations may be utilized in accordance with certain embodiments of the present invention, and various optical properties may be determined in accordance with the various spectra obtained with the present invention, which may include spectra taken at one or more distances from the object or material (and including spectrally reflected light), and spectra taken at or near the surface (e.g., within the critical height, and substantially or wholly excluding spectrally reflected light). In certain embodiments, measurements may be taken in a manner to produce what is sometimes considered a goniometric measurement or assessment of the object or material under evaluation. In

other embodiments, features may sometimes be used with or without certain features. For example, certain applications of aspects of the present invention may utilize perimeter fibers for height/angle determination or correction, while other applications may not. Such refinements, alternatives and specific examples are within the scope of the various embodiments of the present invention.

[0272] Reference is made to copending application filed on even date herewith for Apparatus and Method for Measuring Optical Characteristics of Teeth, and for Method and Apparatus for Detecting and Preventing Counterfeiting, both by the inventors hereof, which are hereby incorporated by reference.

[0273] Additionally, it should be noted that the implements and methodologies may be applied to a wide variety of objects and materials, illustrative examples of which are described elsewhere herein and/or in the co-pending applications referenced above. Still additionally, embodiments and aspects of the present invention may be applied to characterizing gems or precious stones, minerals or other objects such as diamonds, pearls, rubies, sapphires, emeralds, opals, amethyst, corals, and other precious materials. Such gems may be characterized by optical properties (as described elsewhere herein) relating to the surface and/or subsurface characteristics of the object or material. As illustrative examples, such gems may be characterized as part of a buy, sell or other transaction involving the gem, or as part of a valuation assessment for such a transaction or for insurance purposes or the like, and such gems may be measured on subsequent occasions to indicate whether gem has surface contamination or has changed in some respect or if the gem is the same as a previously measured gem, etc. Measuring a gem or other object or material in accordance with the present invention may be used to provide a unique "fingerprint" or set of characteristics or identification for the gem, object or material, thereby enabling subsequent measurements to identify, or confirm the identity or non-identity of, a subsequently measured gem, object or material.

[0274] It also should be noted that the implements and methodologies described in the co-pending applications referenced above also may be applied to embodiments and features of the present invention as described herein, including, for example, material mixing or preparation, remote transmission of optical characteristics data and remote or local creation of a second object or material based thereon (which may be remotely measured with a second instrument, etc.), audio feedback of various types to add operator use, integration with cameras or other implements, posturization or sectoring of an object to be measured with the object measured multiple times and/or in multiple locations, data capture, storage and manipulation in software databases, computers and the like. All such refinements, enhancements and further uses of the present invention are within the scope of the present invention.

What is claimed is:

1. A method comprising the steps of:

moving a probe in proximity to an object, wherein the probe provides light to the surface of the object from one or more light sources, and receives light from the object through a plurality of light receivers, wherein the

plurality of light receivers comprise one or more first light receivers and one or more second light receivers, wherein the one or more first light receivers have a first numerical aperture and the one or more second light receivers have a second numerical aperture different from the first numerical aperture;

determining the intensity of light received by more than one of the light receivers; and
measuring the optical characteristics of the object, wherein the measurement produces data indicative of the optical characteristics of the object.

* * * * *