

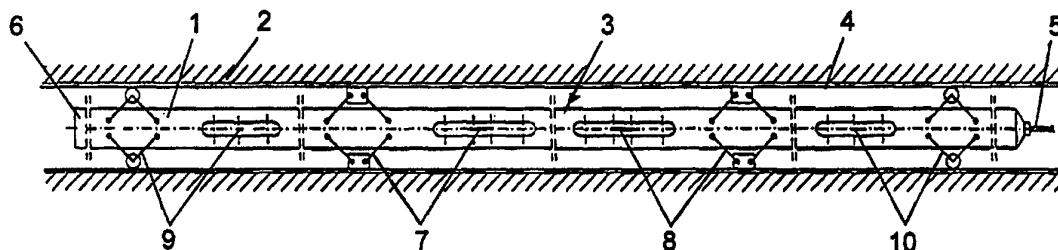

INTERNATIONAL APPLICATION PUBLISHED UNDER THE PATENT COOPERATION TREATY (PCT)

(51) International Patent Classification ⁶ : E21B 23/00, 4/00	A1	(11) International Publication Number: WO 95/21987
		(43) International Publication Date: 17 August 1995 (17.08.95)
<p>(21) International Application Number: PCT/NO95/00034</p> <p>(22) International Filing Date: 14 February 1995 (14.02.95)</p> <p>(30) Priority Data: 940493 14 February 1994 (14.02.94) NO</p> <p>(71) Applicant (for all designated States except US): NORSK HYDRO A.S [NO/NO]; N-0240 Oslo (NO).</p> <p>(72) Inventors; and (75) Inventors/Applicants (for US only): BØE, Einar [NO/NO]; Sauheradvn 13, N-3670 Notodden (NO). CARLSEN, Hans, Paul [NO/NO]; Heddalsvegen 554, N-3670 Notodden (NO). HOLGERSEN, Stig [NO/NO]; Tyrivegen 15C, N-4030 Hinna (NO). HAUGERUD, Olav, Sveinung [NO/NO]; Oterholt, N-3800 Bø i Telemark (NO).</p> <p>(74) Agent: HOFSETH, Svein; Norsk Hydro a.s, N-0240 Oslo (NO).</p>	<p>(81) Designated States: AM, AT, AU, BB, BG, BR, BY, CA, CH, CN, CZ, DE, DK, EE, ES, FI, GB, GE, HU, JP, KE, KG, KP, KR, KZ, LK, LR, LT, LU, LV, MD, MG, MN, MW, MX, NL, NO, NZ, PL, PT, RO, RU, SD, SE, SI, SK, TJ, TT, UA, US, UZ, VN, European patent (AT, BE, CH, DE, DK, ES, FR, GB, GR, IE, IT, LU, MC, NL, PT, SE), OAPI patent (BF, BJ, CF, CG, CI, CM, GA, GN, ML, MR, NE, SN, TD, TG), ARIPO patent (KE, MW, SD, SZ, UG).</p> <p>Published <i>With international search report. Before the expiration of the time limit for amending the claims and to be republished in the event of the receipt of amendments. In English translation (filed in Norwegian).</i></p>	

(54) Title: LOCOMOTIVE OR TRACTOR FOR PULLING EQUIPMENT IN A PIPE OR DRILL HOLE



(57) Abstract

A locomotive or tractor (3) for pulling wire/cable-operated equipment such as measuring, logging and processing equipment in a borehole, pipe etc., comprising a long body with means of propulsion, including one or more motors for propelling the tractor. The means of propulsion consist of at least one set of rollers (13), which can be rotated and are axially inclined in relation to the tractor, with a rounded surface which has a number of sharp parts or edges; the set of rollers (13) are arranged in connection with a driven unit (8), which rotates externally in relation to the support structure (16) of the tractor and which is provided with means (14) which are designed to move the rollers in a radial direction and press them (13) against the wall of the borehole or pipe wall. The tractor is also provided with at least one set of control wheels (31), which are freely supported in relation to the tractor, which can be moved, by means of other means (32, 33), in a radial direction in relation to the tractor and which are designed to roll along the pipe wall or wall of the borehole and keep the tractor centrically oriented in relation to the pipe or borehole and prevent the tractor from rotating.

FOR THE PURPOSES OF INFORMATION ONLY

Codes used to identify States party to the PCT on the front pages of pamphlets publishing international applications under the PCT.

AT	Austria	GB	United Kingdom	MR	Mauritania
AU	Australia	GE	Georgia	MW	Malawi
BB	Barbados	GN	Guinea	NE	Niger
BE	Belgium	GR	Greece	NL	Netherlands
BF	Burkina Faso	HU	Hungary	NO	Norway
BG	Bulgaria	IE	Ireland	NZ	New Zealand
BJ	Benin	IT	Italy	PL	Poland
BR	Brazil	JP	Japan	PT	Portugal
BY	Belarus	KE	Kenya	RO	Romania
CA	Canada	KG	Kyrgystan	RU	Russian Federation
CF	Central African Republic	KP	Democratic People's Republic of Korea	SD	Sudan
CG	Congo	KR	Republic of Korea	SE	Sweden
CH	Switzerland	KZ	Kazakhstan	SI	Slovenia
CI	Côte d'Ivoire	LI	Liechtenstein	SK	Slovakia
CM	Cameroon	LK	Sri Lanka	SN	Senegal
CN	China	LU	Luxembourg	TD	Chad
CS	Czechoslovakia	LV	Latvia	TG	Togo
CZ	Czech Republic	MC	Monaco	TJ	Tajikistan
DE	Germany	MD	Republic of Moldova	TT	Trinidad and Tobago
DK	Denmark	MG	Madagascar	UA	Ukraine
ES	Spain	ML	Mali	US	United States of America
FI	Finland	MN	Mongolia	UZ	Uzbekistan
FR	France			VN	Viet Nam
GA	Gabon				

Locomotive or tractor for pulling equipment in a pipe or drill hole

The present invention concerns a locomotive or a tractor for pulling wire-operated, cable-operated or coiled tube-operated equipment such as measuring, injection and processing equipment in a bore hole, pipe or similar, comprising a long body with means of propulsion, including one or more motors for propulsion of the tractor.

In connection with the production of oil and/or gas from subterranean reservoirs, it is possible, with today's technology, to bore holes which extend both vertically and horizontally for several kilometres down and across below the surface of the earth/sea bed. When a bore hole is formed, equipment is sent down to collect information concerning pressure, temperature and permeability in the reservoir etc. to be able to plan and control the oil and/or gas production. It is also necessary to send components, valves and other equipment down into the drill hole to undertake operations in connection with completing a well or wells in the bore hole ahead of the start of production or in order to be able to undertake the replacement and adjustment of valves and equipment after production has started.

For vertical bore holes or bore holes with a slight inclination it has long been standard to use equipment which is lowered down by means of a cable and which is based on propulsion in the bore hole by means of gravitational force. However, such devices cannot be used for bore holes with a slight inclination or horizontal bore holes which are formed by means of modern drilling technology as stated above.

In PCT patent application DK93/0092 a driven tractor is described for pulling wire/cable-controlled processing or measuring equipment in a subterranean bore hole; it is based on electrohydraulic propulsion. The tractor is provided with a

forward scooter and a rear drive wheel which is designed to be pressed against the wall of the bore hole and roll in the longitudinal direction of the bore hole. The drive wheels are driven by a hydraulic motor. This motor gains its energy from the hydraulic oil in a hydraulic system which is driven by a high-pressure pump. The high-pressure pump is, in turn, driven by an electric motor which, in turn, gains its energy from a battery arranged in the tractor.

The tractor in question in accordance with the above PCT application is complicated and expensive and has a number of disadvantages. Firstly, the friction between the drive wheels and the bore hole wall in such a solution will be low and the pulling properties of the tractor will, consequently, be very poor. Secondly, the efficiency of such an electrohydraulic drive unit as is used for the tractor is very poor and the use of energy low. This, coupled with the fact that the drive energy is taken from a battery arranged in the tractor, means that the range, i.e. the operation time of the tractor will be very limited. Use of the battery as a source of energy will also increase the weight of the tractor and make it less easy to handle and require more energy. Taken as a whole, the known tractor in question thus represents a very poor solution; in all probability it will not be possible to use it in practice.

In US patent no. 4.485.870 a two-stage locomotive for pulling a wire and/or cable is shown and described; it is designed to be connected to a "stinger" for transporting cable-operated logging equipment and tools down into a subterranean bore hole with high directional deviation. The locomotive or tractor is propelled by means of the bore hole liquid which circulates in the drill stem; the tractor functions in principle like a "stopper" in the drill stem and is pressed forward in it by the drill liquid. When the tractor with the "stinger" and equipment is to be returned to the surface, it is drawn back by means of the connecting wire/cable.

This solution has very limited functionality as the tractor is driven by means of the drill liquid and must be propelled through the drill pipe or drill stem and thus cannot be propelled along the full length of the bore hole. The solution is also restricted by the fact that the diameter of the pipe in which it is propelled must be the same along the full length of the propulsion pipe. This means that the tractor in question cannot be propelled in a pipe which passes from a smaller to a larger diameter or vice-versa, for example from a production pipe to a drainage pipe in an oil/gas well. Since the tractor is pulled back by means of the connection wire/cable, the distance down into a bore hole, to which the tractor can be sent, will be very restricted by the limited strength of the wire/cable.

With the present invention it has been possible to create a tractor for pulling equipment in a pipe or bore hole which is a considerable improvement on known solutions, i.e. which has considerably better pulling properties than the known tractors and which is self-adjusting in relation to pipes with different diameters and which can be passed from a pipe with a large diameter to a pipe with a smaller diameter or vice-versa. The tractor is also simple and easy to build and maintain and has a low weight. It can be driven in both directions without adding load to the wire/cable connection and therefore has, among other things, a large range in long bore holes with a great inclination or horizontal well bore holes. The tractor is "flexible" to use and can be connected to various types of equipment which are used in subterranean bore holes in connection with drilling for and production of oil and gas, for example logging equipment, equipment for oil/gas sampling, equipment for cleaning lining pipes/production pipes internally, equipment for collecting or retrieving tools which have become stuck in a well, equipment for injecting trace elements or similar, equipment for operating and replacing valves in a well and for placing equipment in a well. Another important advantage is that the tractor can be built with a very small diameter and can be passed through pipes with a diameter of 4.5". This makes it possible, among other things, to use the tractor in long horizontal wells drilled with a small

diameter.

The present invention is characterised in that the means of propulsion of the tractor consist of at least one set of rollers, which can be rotated and are axially inclined in relation to the tractor, with a rounded surface which has a number of sharp parts or edges in the direction of rotation; the set of rollers are arranged in connection with a driven unit which rotates externally in relation to the tractor's support structure and which is designed to press the rollers against the wall of the bore hole or the pipe wall, as well as at least one set of control wheels which are freely supported in relation to the tractor, which can move in a radial direction in relation to the tractor and which are designed to roll along the pipe wall or bore hole wall and keep the tractor centrally oriented in relation to the pipe or bore hole and prevent the tractor from rotating, as stated in the enclosed claim 1.

The dependent claims 2-10 state the advantageous features of the present invention.

The present invention is to be described in the following in further detail by means of examples and with reference to the drawings of which:

- Fig. 1 shows a diagram of a tractor in accordance with the present invention "lowered" into a bore hole or pipe;
- Fig. 2 shows, divided up into numbered sections and in larger scale, a sectional elevation of the tractor shown in fig. 1;
- Fig. 3 shows, in even larger scale, details of the tractor's means of propulsion;
- Fig. 4 shows, in the same, even larger scale, details of the tractor's control wheels.

Fig. 5 shows, in large scale, details of the means of propulsion shown in fig. 3.

Fig. 1 shows a diagram, as stated, of a tractor 3 in accordance with the present invention. It consists of a long body 1 which is designed to be able to be lowered into a bore hole 2 or similar with an internal lining or pipe 4. The tractor can preferably have a circular or mainly circular cross-section (not shown) and is thus adapted to the normal configuration of a pipe or bore hole.

One end of the tractor 3 is connected to a cable 5 for transferring signals and current for controlling and operating the tractor and equipment connected to it. The cable extends up to a cable drum or similar (not shown) on the surface of the earth or sea, for example on a drilling rig, platform etc.

The other end 6 of the tractor 3 is designed to be connected to equipment such as logging equipment, sampling equipment, injection equipment or other equipment which can be used to carry out various operations in a bore hole or oil well (the equipment is not shown).

The tractor 3 is provided with two sets of means of propulsion 7, 8 and two sets of means of control 9, 10. These are to be described in further detail with reference to the subsequent figures.

Fig. 2 shows, in larger scale, partly in section and partly from the outside, the tractor shown in Fig. 1. The figure is divided up into sections 1-34 to provide an overview and to make it easier to understand the invention. Sections 1, 2 and 3 show the end of the tractor which is closest to the cable 5 and contain electronic components which form part of the operating and control system of the tractor and any operating equipment connected to it. These components are not considered, in themselves, as representing a part of the present invention and no further comment will thus be made with regard to them here.

Sections 4 and 5 show an electrically driven hydraulic pump 11 which provides pressurised fluid to the means of propulsion and control 7, 8, 9 and 10 via channels or bore holes 12 (not shown coherently in detail).

The tractor in accordance with the present invention is, as mentioned earlier, provided with at least one set of means of propulsion. For the tractor shown in the example in the figures, it has been expedient to use two sets. One set 8 is shown in sections 15, 16, 17, 18 and 19 while the other set 7 is shown in sections 20, 21, 22, 23 and 24. The details of each set 7 or 8 of the means of propulsion, which are displaced in relation to one another in the longitudinal direction of the tractor, will be described in further detail with simultaneous reference to Fig. 3. Each set of means of propulsion 7 or 8 consists of two sets of rollers 13 which are arranged, so that they can freely rotate, on pantographs 14, diametrically opposite each other. The rollers 13 are inclined with an angle α in relation to the longitudinal part (see fig. 5) and are designed to be pressed, by means of the pantographs 14, to lie against the wall of the lining or pipe 4. The sharp elevations or edges 15 on the rollers are pressed partly into the material of the pipe wall and work like threaded rollers in a threading tool, whereby a good "grip" on the pipe is created to move the tractor forward. The propulsion of the tractor is thus achieved by rotating the pantographs 14 together with the rollers 13 around the tractor's supporting structure, i.e. the wheel shaft 16. The rotation is produced by means of one electric motor 37 for each set of means of propulsion 8, 9. Each of the pantographs 14 in each set of rollers consists of a roller shaft 17 which is connected with an articulated joint to rotating arms 18, 19. One pair of arms 18 is connected with an articulated joint to rotating sleeves 20 which are connected to the motor 37, whereas the other pair of arms 19 is connected with an articulated joint to a piston 21 (see Fig. 2) via a spring system 22 and a piston rod 23. The spring system 22 comprises a spring holder 24 which is connected to the rod 23, the spring 25 and a slide shoe 26 to which the arms 19 are articulated. The movement of the rollers 13 in radial direction is achieved by the slide

shoe 26 displacing, by means of the piston 21, via the piston rod and the springs, the point of articulation 28 of the arms axially as shown with the arrows 27. The point of articulation 29 of the other arms 18 is kept in a stationary position. Thus the means of propulsion, i.e. the rollers can be adapted to pipes with different diameters. The compressive force of the rollers against the pipe wall is adjusted, in turn, by the desired pressure in the hydraulic system which is driven by pump 11, as stated earlier. The pressure is kept constant for the current diameter of the pipe and the pressure which the rollers are required to exert against the pipe wall. The intention of the springs, on the other hand, is to compensate for minor irregularities in the pipe wall.

As stated, there are two sets of rollers 13 for each set of means of propulsion 7, 8. Each set of rollers 13 is, however, pressed out by a common cylinder unit 30 (see sections 17/30 in Fig. 2) with two separate pistons 24 (one set of pistons for each set of rollers). The primary task of the rollers is, as stated above, to create propulsion for the tractors. A secondary task is to keep the tractor centric in relation to the pipe/bore hole. Therefore, the two sets of rollers for each set of means of propulsion 7 or 8 are rotated through 90° in relation to one another.

The two sets of means of propulsion 7, 8 also rotate in opposite directions to each other to balance out the forces of rotation.

In addition to the means of propulsion 7, 8 the tractor is, as stated earlier, also equipped with two sets of control wheels 9, 10 as shown in sections 8, 9, 10 and 11 and 28, 29, 30, 31 and 32 in Fig. 2. Each set of wheels 9 or 10 consists of two pairs of wheels 31. Fig. 4 shows in larger scale a pair of wheels 31 as shown in Fig. 2. The wheels are supported freely diametrically opposite one another in the point of articulation of the pantograph arms 32, 33. The pantograph arm 32 is, in turn, connected with an articulated joint to, respectively, the piston and spring arrangement 21, 22 and a stationary part 34 in the

body of the tractor 1. The method of operation and the structure of the spring and piston arrangement 21, 22 are the same as that of the means of propulsion 7, 8. The piston 21 is also driven by compressed fluid from the same hydraulic system as the means of propulsion.

The wheels 31, which have a peripheral part with a pointed shape, are, as will be clear from the above, designed to be moved radially out and in and to be pressed against the pipe wall 4. The wheels are pressed into the pipe wall with such high force that the wheels partially penetrate the wall in such a way that the tractor is prevented from rotating. The wheels 31 also have the function that they keep the tractor centrically oriented in the pipe or bore hole 4 ; each pair of wheels 31 in each set of wheels 9 or 10 is arranged at a 90° angle to the other pair (see Fig. 2).

Fig. 5 shows, as stated, in large scale, one of the rollers 13 with pantograph arms 18, 19 seen respectively from the side, A) and from above, B) and the roller itself pulled out and in perspective, C).

It is expedient for the rollers 13 to have a rounded or oval shape and to be provided with a number of sharp (pointed) edges 15. The intention of the rounded shape is that the rollers can easily pass over elevations or restrictions, for example at the transition from a larger to a smaller pipe dimension.

Preferably the rollers can be composed of a number of discs 35, for example of hard metal, each of which has sharp, peripheral edges 15, as shown in fig. 5 C). The discs rotate freely on the shaft 36, between the ends of the articulated arms 40, 41, each of which is connected by means of a hinge to the pantographs 18, 19.

Regarding the bearings for the wheels 31, the rollers 13, the motors 37 and the support for the means of propulsion 7, 8 these parts will not be described in detail as an expert will have the

skills to adapt these in the solution as it is stated above. The same applies for ducts and seals in the hydraulic system driven by the pump 11.

Regarding further details of the operation of the pump 11 and motors 37, they receive electricity from the surface (platform etc.) via the cable 5. The cables which carry the electricity are fed to the motors via ducts or bore holes 38 (not shown in full detail). The points 39 indicate the electrical contacts between the various parts of the tractor.

A tractor in accordance with the present invention can, typically, have the following dimensions/characteristic values:

External diameter	82.6 mm (3.25")
Length	7-8 m
Weight	200-400 kg
Power consumption	5 kW
Max. velocity	approx. 300 m/h
Pull	min. 20.0 kN
Can be run in pipes/ linings with:	5.58" diameter
Hydrostatic pressure	690 bar
Max. temp.	180°C

It should be noted that the present invention as it is described in the claims is not restricted to the number of sets of wheels 9, 10 or rollers 7, 8 which are shown in the drawings. Thus just one set of each or more than two such sets can be used. Furthermore, the pantographs can be operated pneumatically instead of hydraulically.

Claims

1. A locomotive or tractor (1) for pulling wire-operated, cable-operated or coiled tube-operated equipment such as measurement, injection, washing and processing equipment in a bore hole, pipe etc., comprising a long body with means of propulsion, including one or more motors for propelling the tractor,
c h a r a c t e r i s e d i n t h a t
the means of propulsion consist of at least one set of rollers (13), which can be rotated and are axially inclined in relation to the tractor, with a rounded surface which has a number of sharp parts or edges (15) in the direction of rotation; the set of rollers (13) are arranged in connection with a driven unit (8), which rotates externally in relation to the support structure (16) of the tractor and which is provided with means (14) which are designed to move the rollers in a radial direction and press them (13) against the wall of the bore hole or pipe wall, and at least one set of control wheels (31), which are freely supported in relation to the tractor, which can be moved, by means of other means (32, 33), in a radial direction in relation to the tractor and which are designed to roll along the pipe wall or wall of the bore hole and keep the tractor centrically oriented in relation to the pipe or bore hole and prevent the tractor from rotating.
2. A locomotive or tractor in accordance with claim 1,
c h a r a c t e r i s e d i n t h a t
it is provided with two rotating, driven units (7, 8), each comprising two sets of rollers (13).
3. A locomotive or tractor in accordance with claim 1 or 2,
c h a r a c t e r i s e d i n t h a t
the rotating unit(s) comprise(s) sleeve-like or ring-shaped parts (20, 23, 24, 26) which are supported around a shaft (16).

4. A locomotive or tractor in accordance with claims 1-3, characterised in that the rollers (13) are supported in pantographs or pantograph-like devices comprising two arms (18, 19), each of which is connected, at one end, with an articulated joint to the rotating parts (20, 23, 26) and is connected, at the other end, to an articulated joint to an intermediate roller shaft (17).
5. A locomotive or tractor in accordance with claims 1-4, characterised in that the rollers (13) are composed of a number of discs (35), each of which is provided with sharp edges (15), and the diameter of which decreases towards the ends of the rollers.
6. A locomotive or tractor in accordance with claims 1-5, characterised in that one arm (19) is connected to a hydraulically or pneumatically driven, axially displaceable piston (21) via a spring arrangement (25) and a slide ring (26).
7. A locomotive or tractor in accordance with claims 1-6, characterised in that the pantograph (14) is driven, via the arms (18) and a rotating sleeve (20), by an electric motor (37).
8. A locomotive or tractor in accordance with claim 1, characterised in that it is provided with two sets of control wheels (9, 10), each of which comprises two wheels (31).
9. A locomotive or tractor in accordance with claims 1 and 8, characterised in that the wheels (31) are supported in pantographs comprising two arms (32, 33), each of which is connected at one end with an articulated joint to the tractor (1) and is connected at the other end to a support for the respective wheel (31).

10. A locomotive or tractor in accordance with claims 1 and 8-9, characterised in that one arm (32) is connected to an axially displaceable, hydraulically or pneumatically driven ring piston (21) via a spring arrangement (22) and a slide ring (26).

FIG. 1

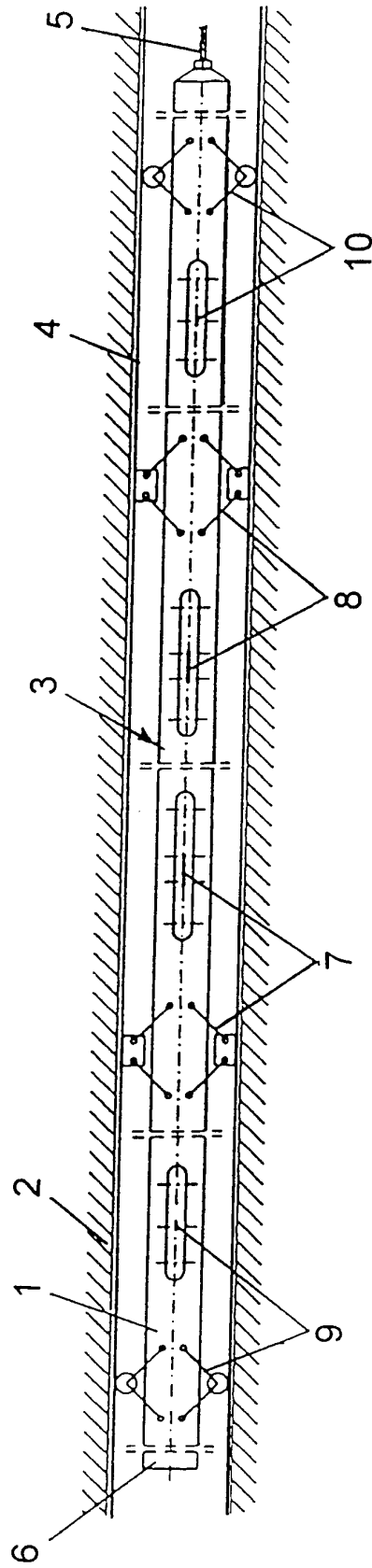

FIG 2

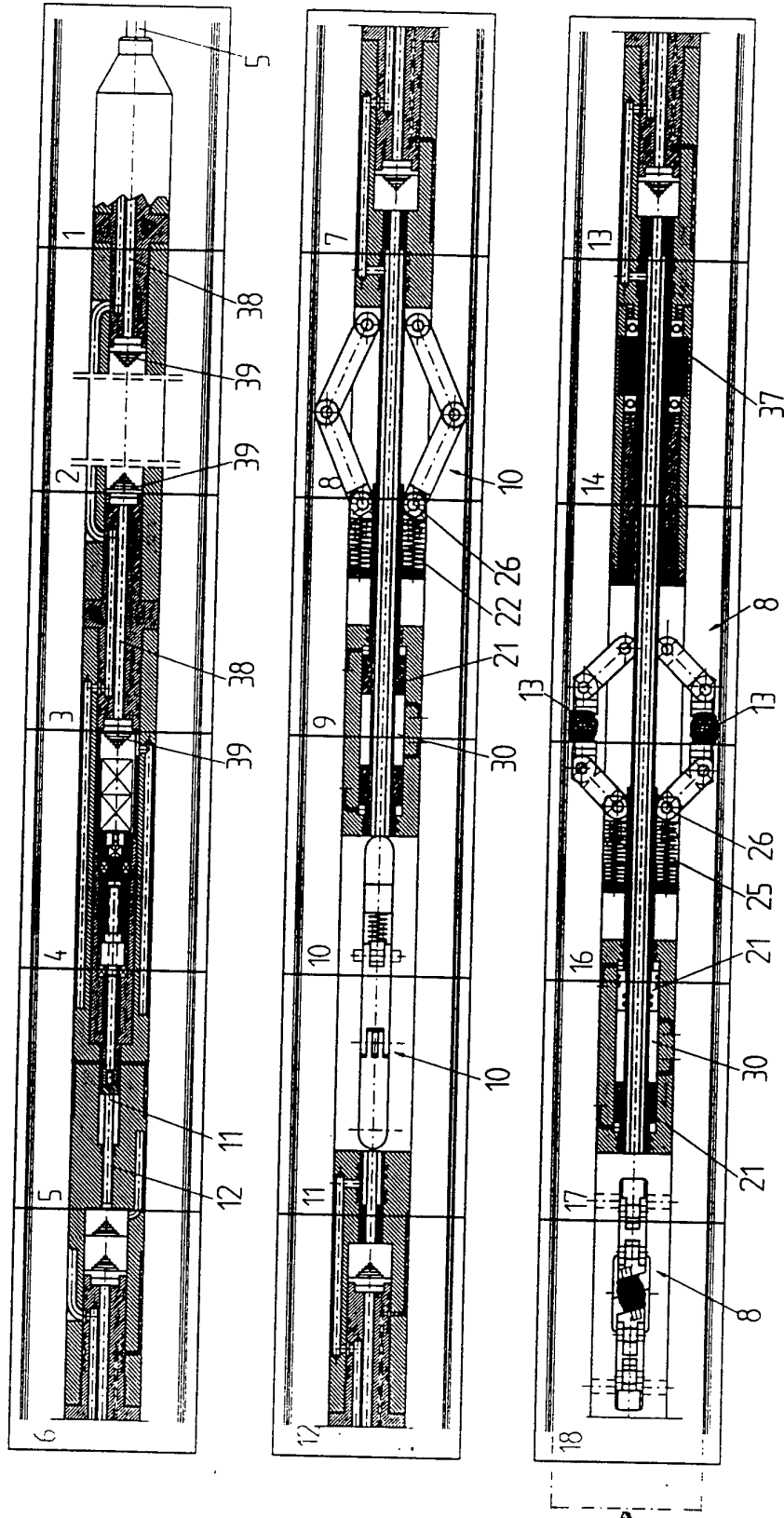

FIG.2 (for ts.)

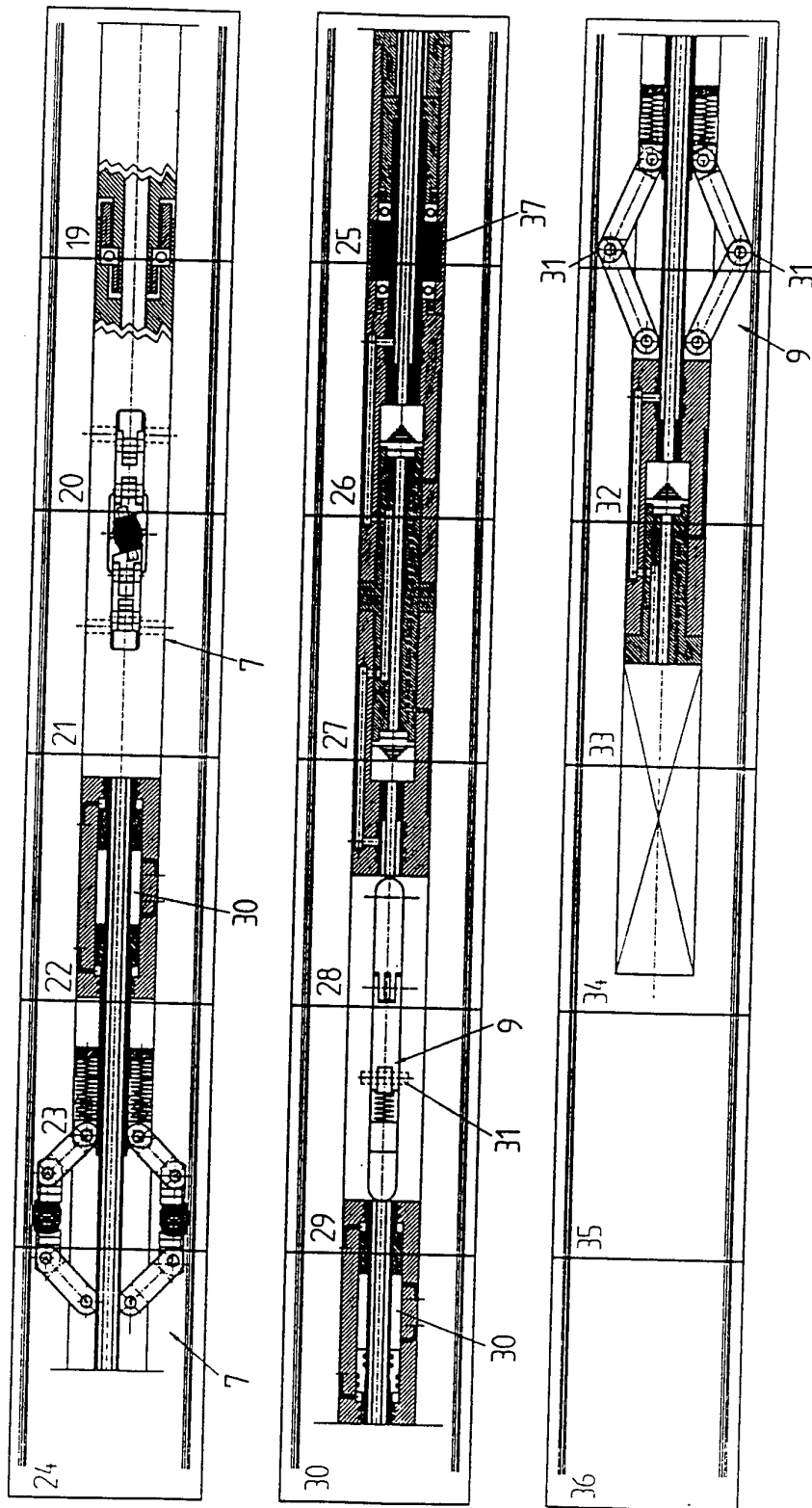
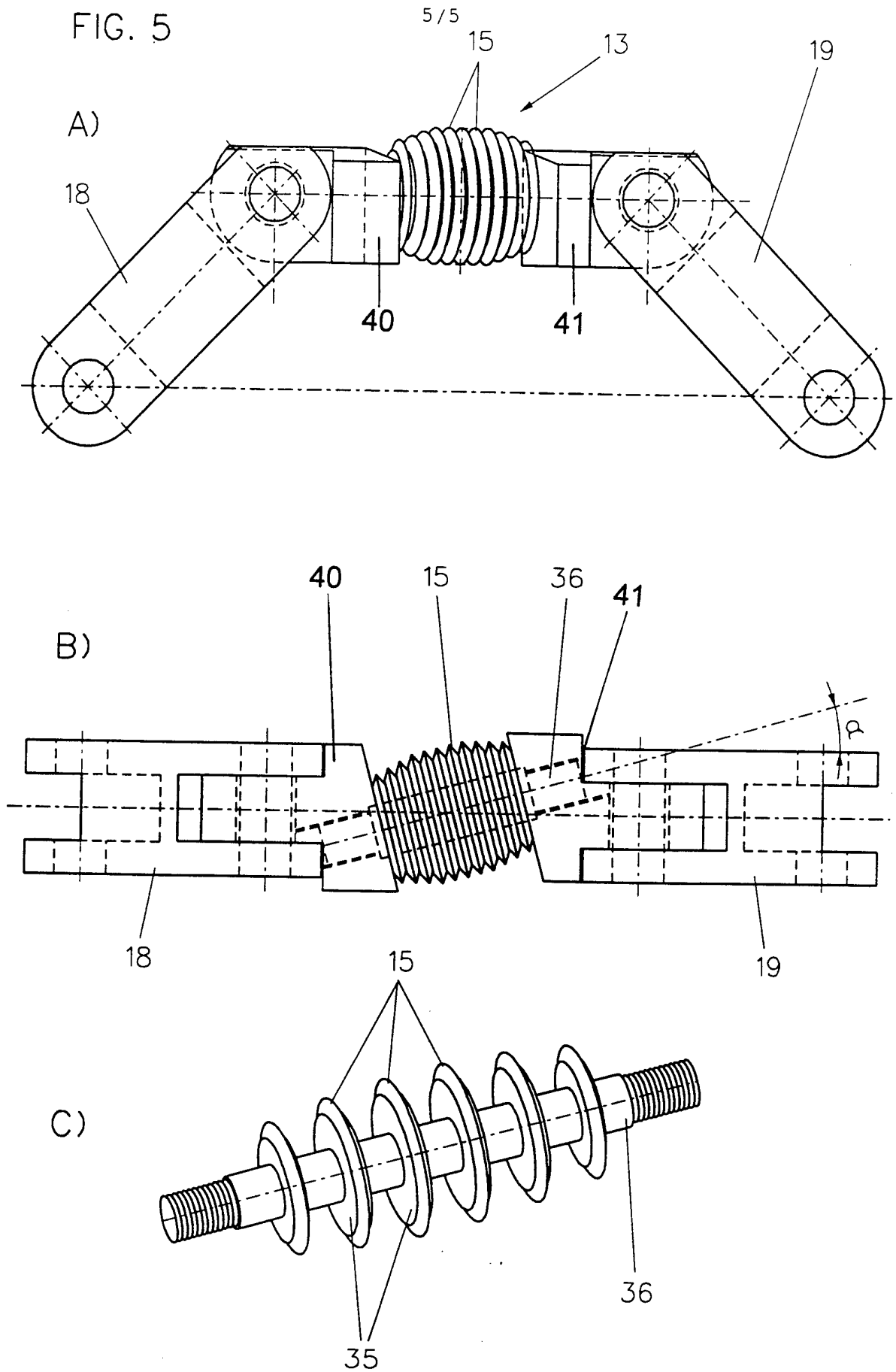

FIG. 5



INTERNATIONAL SEARCH REPORT

International application No.

PCT/NO 95/00034

A. CLASSIFICATION OF SUBJECT MATTER		
IPC6: E21B 23/00, E21B 4/00 According to International Patent Classification (IPC) or to both national classification and IPC		
B. FIELDS SEARCHED		
Minimum documentation searched (classification system followed by classification symbols)		
IPC6: E21B		
Documentation searched other than minimum documentation to the extent that such documents are included in the fields searched		
SE,DK,FI,NO classes as above		
Electronic data base consulted during the international search (name of data base and, where practicable, search terms used)		
C. DOCUMENTS CONSIDERED TO BE RELEVANT		
Category*	Citation of document, with indication, where appropriate, of the relevant passages	Relevant to claim No.
X	DE, B2, 2439063 (INSTITUT GORNOGO DELA SIBIRSKOGO OTDELENIJA AKDAEMII NAUK SSSR), 27 November 1980 (27.11.80), column 4, line 25 - line 55, figures 7-9, claim 6 --	1-3
A	GB, A, 894117 (HALLIBURTON TUCKER LIMITED), 18 April 1962 (18.04.62) -- -----	1-10
<input type="checkbox"/> Further documents are listed in the continuation of Box C. <input checked="" type="checkbox"/> See patent family annex.		
<p>* Special categories of cited documents:</p> <p>"A" document defining the general state of the art which is not considered to be of particular relevance</p> <p>"E" earlier document but published on or after the international filing date</p> <p>"L" document which may throw doubts on priority claim(s) or which is cited to establish the publication date of another citation or other special reason (as specified)</p> <p>"O" document referring to an oral disclosure, use, exhibition or other means</p> <p>"P" document published prior to the international filing date but later than the priority date claimed</p> <p>"T" later document published after the international filing date or priority date and not in conflict with the application but cited to understand the principle or theory underlying the invention</p> <p>"X" document of particular relevance: the claimed invention cannot be considered novel or cannot be considered to involve an inventive step when the document is taken alone</p> <p>"Y" document of particular relevance: the claimed invention cannot be considered to involve an inventive step when the document is combined with one or more other such documents, such combination being obvious to a person skilled in the art</p> <p>"&" document member of the same patent family</p>		
Date of the actual completion of the international search		Date of mailing of the international search report
23 May 1995		07 -06- 1995
Name and mailing address of the ISA/ Swedish Patent Office Box 5055, S-102 42 STOCKHOLM Facsimile No. +46 8 666 02 86		Authorized officer Christer Bäcknert Telephone No. +46 8 782 25 00

INTERNATIONAL SEARCH REPORT
Information on patent family members

01/04/95

International application No.
PCT/NO 95/00034

Patent document cited in search report	Publication date	Patent family member(s)	Publication date
DE-B2- 2439063	27/11/80	NONE	
GB-A- 894117	18/04/62	NONE	