

(19) World Intellectual Property  
Organization  
International Bureau



(43) International Publication Date  
16 September 2004 (16.09.2004)

PCT

(10) International Publication Number  
WO 2004/079207 A2

(51) International Patent Classification<sup>7</sup>: F16B

GB, GD, GE, GH, GM, HR, HU, ID, IL, IN, IS, JP, KE, KG, KP, KR, KZ, LC, LK, LR, LS, LT, LU, LV, MA, MD, MG, MK, MN, MW, MX, MZ, NA, NI, NO, NZ, OM, PG, PH, PL, PT, RO, RU, SC, SD, SE, SG, SK, SL, SY, TJ, TM, TN, TR, TT, TZ, UA, UG, US, UZ, VC, VN, YU, ZA, ZM, ZW.

(21) International Application Number:  
PCT/US2004/006280

(22) International Filing Date: 1 March 2004 (01.03.2004)

(25) Filing Language: English

(84) Designated States (unless otherwise indicated, for every kind of regional protection available): ARIPO (BW, GH, GM, KE, LS, MW, MZ, SD, SL, SZ, TZ, UG, ZM, ZW), Eurasian (AM, AZ, BY, KG, KZ, MD, RU, TJ, TM), European (AT, BE, BG, CH, CY, CZ, DE, DK, EE, ES, FI, FR, GB, GR, HU, IE, IT, LU, MC, NL, PL, PT, RO, SE, SI, SK, TR), OAPI (BF, BJ, CF, CG, CI, CM, GA, GN, GQ, GW, ML, MR, NE, SN, TD, TG).

(26) Publication Language: English

(30) Priority Data:  
60/450,656 1 March 2003 (01.03.2003) US

(71) Applicant and

(72) Inventor: BRACKETT, Charles, T. [US/US]; 13440 Gerona Drive, North, Jacksonville, FL 32246 (US).

Declaration under Rule 4.17:  
— of inventorship (Rule 4.17(iv)) for US only

(74) Agent: MAYNARD, Jeffrey, C.; 154 Barbara Road, Sevens Park, MD 21146 (US).

Published:  
— without international search report and to be republished upon receipt of that report

(81) Designated States (unless otherwise indicated, for every kind of national protection available): AE, AG, AL, AM, AT, AU, AZ, BA, BB, BG, BR, BW, BY, BZ, CA, CH, CN, CO, CR, CU, CZ, DE, DK, DM, DZ, EC, EE, EG, ES, FI,

For two-letter codes and other abbreviations, refer to the "Guidance Notes on Codes and Abbreviations" appearing at the beginning of each regular issue of the PCT Gazette.

(54) Title: WIRE BOLT

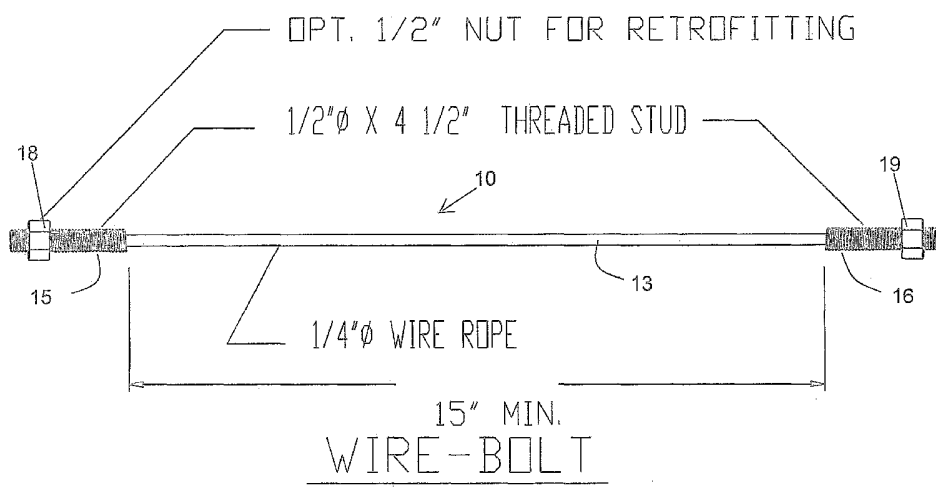

(57) Abstract: A wire bolt comprising an elongated section of wire rope with a section of threaded stud attached to each end is disclosed for use in reinforcing concrete structures. Part of the wire rope portion is coated with a substance to prevent that portion from bonding with the concrete. The threaded rod portion can be attached within the concrete by epoxy or attached to the concrete by appropriate mechanical means. The wire bolt can be attached to a concrete building structure during initial construction of a structure or retrofit into existing structures. Wire bolts should be installed in areas susceptible to shear or bending failure and serve to prevent the concrete sections from separating in a seismic event.

WO 2004/079207 A2

## Wire Bolt

### Technical Field

This invention relates generally to reinforcements for building structures, and more particularly to structures in seismic regions where building codes dictate that these structures be protected against structural failure and/or to save lives of occupants. In particular, the present invention relates to a wire bolt system for reinforcing structures to increase their ability to withstand seismic forces. The wire bolt system can be installed in new structures or retrofit into existing structures. The present invention also relates to a wire bolt system that provides additional reinforcements for an existing structure.

### Background Art

Concrete and other similar substances have been known and used for many years. However, no matter how much care is taken in the preparation or placement of concrete and concrete-like structures, cracks, voids, and fissures can develop causing various problems. The problem of cracking or of defective joints in concrete structures is a source of concern. In particular, when a concrete structure is subjected to tremendous forces, such as during an earthquake, large cracks and even total failure of the structure can result.

The reinforcement of preexisting structures comprising concrete such as buildings, bridge columns, piers, bridges, and the like by the use of a sheet material, in which high strength fibers are affixed to the structures with resin or other filler material, and then left to cure, is generally known.

Furthermore, other reinforcement methods are also known. For example, U.S. Patent No. 6,308,478 to Kintscher et al. describes a construction method wherein wire rope is embedded in the structure alongside metal reinforcing bars so that adjacent components can be connected together.

U.S. Patent No. 6,634,830 to Marshall describes a method for post tensioning wire rope to repair concrete pilings.

### Disclosure of Invention

Connections between concrete members and attachments to them of other materials for structures located in seismic regions have resulted into a major new area of structural design. This invention focuses on the use of wire rope with or without

end attachments placed in new or retrofitted into existing concrete structural members. The wire bolt provides an additional level of structural redundancy in areas of concrete members where failure is caused by a seismic event. The invention is applicable to both new design and construction and for retrofitting into existing structures.

The wire bolt disclosed herein can be used in addition to current seismic design procedures, except to be used in addition to them. The wire bolt will remain attached after the concrete has failed and the steel rebar bond has been broken and failed in tension and shear. The wire bolt is designed to remain elastic throughout any seismic event, maintain its bond with the concrete, and hold the structure together long enough at least to provide a much higher degree of life safety for occupants than existing design and construction methods.

It is an object of the present invention to provide a wire bolt for use in a structure of a new building that reinforces the structure against damage in a seismic event, such as an earthquake.

It is a further object of the present invention to enable installation of a wire bolt system after the building is complete.

It is another object of the present invention to provide a wire bolt system for a concrete building that provides reinforcement to the floors and support structure, thereby providing greater resistance to damage during a seismic event.

#### Brief Description of the Drawings

The above and other features, aspects, and advantages of the present invention are considered in more detail, in relation to the following description of embodiments thereof shown in the accompanying drawings, in which:

FIG. 1 shows a wire bolt embodiment according to the present invention;

FIG. 2 shows a wire bolt used as a concrete beam reinforcement according to the present invention;

FIG. 3 shows a floor slab reinforcement according to the present invention;

FIG. 4 shows an alternate floor slab reinforcement according to the present invention; and

FIG. 5 shows a test device used to verify the present invention.

Best Mode(s) for Carrying Out the Invention

Referring to Figure 1, a wire bolt design consistent with the present invention is illustrated. Such wire bolt, indicated generally as 10, consists of a section of wire rope 13 with a solid steel attachment 15, 16 swaged to each end. As shown in Figure 1, attachments 15, 16 may be solid plain or threaded short sections of steel that are attached to each end of wire rope 13 to form the wire bolt 10. The attachments 15, 16 are usually attached to the wire rope by cold forming of metal called swaging, which is known in the art. Other methods of attaching may be used. The embodiment shown in Figure 1 includes a ¼-inch  $\phi$  wire rope portion 13 at least fifteen inches long, having a ½-inch  $\phi$  threaded attachment 15, 16 approximately 4½-inches long. Optionally, the attachment portions 15, 16 may include an appropriately sized nut 18, 19 threaded thereon. In a preferred embodiment, the wire rope portion 13 is coated with a substance to prevent that portion from bonding with concrete.

Wire bolt 10 can be used in a variety of applications, such as shown in Figures 2, 3, and 4. The wire bolt can be installed during initial construction at locations susceptible to failure such as near the bottom of a concrete floor slab where cracks might form due to bending, or near the support columns where shear stresses may cause cracking. The wire bolt can also be retrofitted to existing structures. For retrofitting, a socket is formed from external of the concrete beam or column, as shown in Figures 3 and 4. Such socket should be deep enough to extend sufficiently beyond the failure zone. Epoxy, or other suitable adhesive is injected into the socket and a wire bolt is inserted. The wire bolt should be sufficient length to extend to the end of the socket while leaving sufficient threaded portion exposed to attach a nut to the threaded portion. As is known in the art, a metal plate may be installed with the nut to provide a firm seating surface. Such metal plate can be left flush with the edge of the concrete. The metal plate can be fixed in place by a suitable adhesive, such as epoxy and the like.

There are several sizes of stranded wire rope cable that can be used in the present invention, as shown in Table 1. Wire Rope has two kinds of stretch within its elastic limit. These are its elastic and constructional stretch and both must be considered in design.

Table 1 Wire Rope Capacities

Diameter (in)	Nominal Strength (tons)
3/16	2.14
1/4	3.77
5/16	5.86
3/8	8.39
1/2	14.8
9/16	18.6
5/8	22.9
3/4	32.7
7/8	44.3
1"	57.5

5            Elastic stretch is the temporary elongation of the wire rope that occurs while under load. The wire rope if kept below its elastic limit of about 60% of its ultimate breaking strength will return to its normal length.

              The elastic stretch is proportional to the load times the length of wire rope and inversely proportional by its modulus of elasticity and area. The equation used to  
 10      calculate elastic stretch is as follows:

$$\Delta L = \frac{\Delta P \times L}{A \times E}$$

*ΔL=Change of overall length*

*ΔP=Change in load on rope*

*L=Length of rope*

*A=Metalic area of rope*

*E=Modulus of elasticity*

15

              Constructional stretch is a permanent elongation of the wire rope. This permanent stretch starts immediately when the load is applied. This is caused by the strands adjusting themselves into the small voids between the strands and their seating onto the core. The normal length of constructional stretch is approximately 1/2% of the  
 20      length of rope under load. The constructional stretch for short segments of wire can be removed in two ways, pre-stretching and post tensioning. Pre-stretching the load should be equal to or greater than the working load but must not exceed the elastic limit. Post tensioning is performed at installation of the wire bolt during construction

and is used only in the wire bolt to pre-stretch the wire rope portion, which is then released to post-tension.

A wire bolt as taught herein can be installed in new or existing concrete in a variety of applications. The embedded attachments behavior will follow the same requirement as any bonded or grouted anchor with their strength dependant on  
 5 embedment, edge distance spacing and type of material embedded in. The attachments of short sections of allthread (A-36) steel rods have strength based on size and embedment. The strength of epoxy embedded threaded stud in tension has been tested and documented by many sources and on average are close to the same  
 10 capacity provided here in Table 2 for embedment in 4000 psi concrete.

Table 2 Threaded Attachments

Rod Size	Embedment	Capacity
3/8	4-1/2"	2,835 #
1/2	4-1/2"	4,360 #
5/8	5-5/8"	7,545 #
3/4	6-3/4"	9,735 #
7/8	7-7/8"	10,595 #
1"	9"	14,890 #

15 A wire bolt that is pres-stretched can be installed by embedment in the concrete during new construction or embedded in epoxy in pre-drilled holes in existing concrete. A part of the wire rope portion of such wire bolt should be coated to prevent bonding to the concrete in order to allow the elastic properties of the wire to move during an earthquake.

20 In one embodiment, a wire bolt is placed across the normal shear and bending failure zones in concrete beams and their connection to support columns, as shown in Figure 2.

In a second embodiment, a wire bolt is installed along a concrete floor slab where it attaches to main support beams, as shown in Figure 3.

25 In another embodiment, a wire bolt is used to tie a floor slab to a CMU wall, as shown in Figure 4.

A series of tests was performed to determine if a wire bolt, when post installed in existing concrete, could withstand the forces associated with a seismic event. A test stand as shown in Figure 5 applied cyclic loading to simulate the effects of an

earthquake in order to determine if the construction stretch is eliminated and if the wire bolt will return to normal or its original position. If so, this would prove the ability of such wire bolt to hold two sections of concrete together after normal failure of the concrete and steel.

5           The test was conducted to determine what, if any, permanent deformation or stretch would result from a seismic event. Using the test stand shown in Figure 5, tests were performed on wire bolts embedded into concrete on one end with the other end attached to a hydraulic test cylinder. The same load of 2500 lbs. was applied and then returned to zero 60 times to simulate a cyclic load of an earthquake. The  
 10       deformation was recorded each time at maximum load and the permanent deformation, if any, was recorded after returning to 0# load.

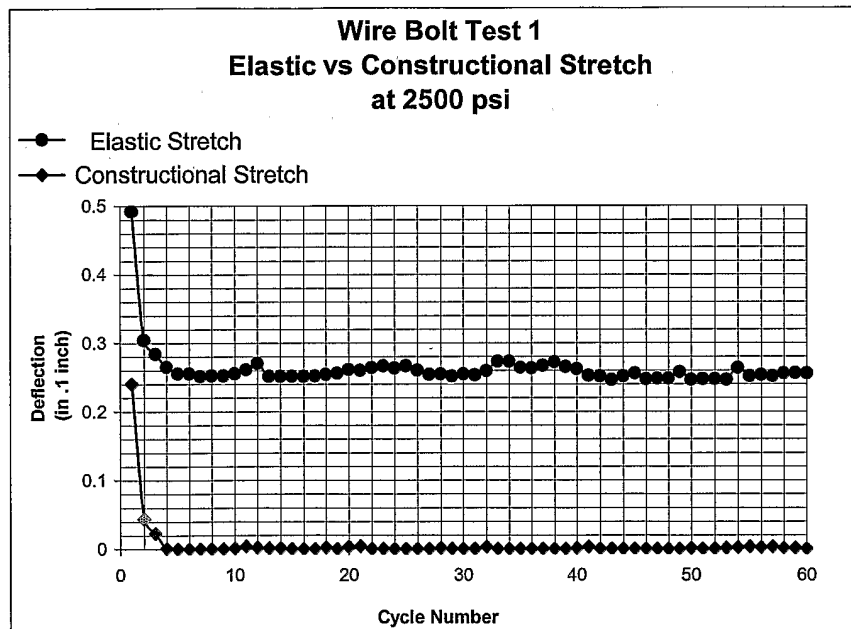

In both Test 1 and Test 2, elongation of the wire bolt was 80% completed after only two cycles of 2500 psi. Elongation was approximately 99% at the 3<sup>rd</sup> cycle. The  
 15       elastic stretch went from 0.49" and .48" to approximately .3" in one cycle, and then averaged only .25" after the 3<sup>rd</sup> cycle. This indicates that after a concrete and steel failure the wire bolt will only allow a separation of 1/4" during each cycle. This test also proves that the epoxy connection will not fail under a cyclic load of 2500 psi for the size of wire bolt. Therefore, wire bolts should be pre-stretched to eliminate the  
 20       initial constructional permanent stretch.

All of the factors will change with different lengths and sizes of wire rope and threaded studs. The results can be predicated based on the methods presented.

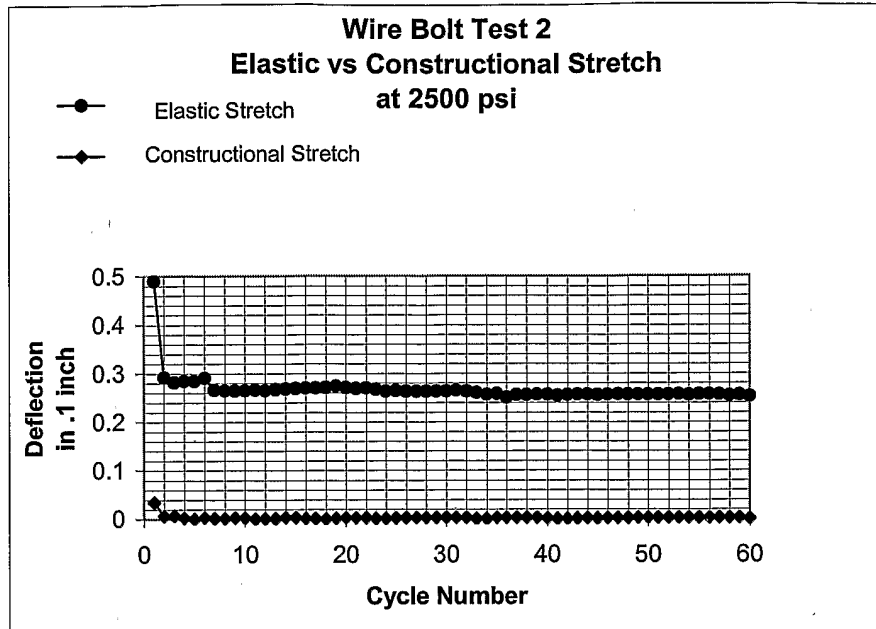

5

Industrial Applicability

The wire bolt provides an additional redundant load path for concrete structures and helps to prevent loss of life. The test demonstrated that elastic stretch was achieved after a permanent deformation in the wire bolt and would return to zero after each cycle. It is proposed that it be used in both new construction and in existing structures by retrofitting them by drilling and epoxying them in place.

10



Claims

What is claimed is:

- 1 1. A wire bolt for strengthening or repairing concrete, said wire bolt comprising:  
2 an elongated section of wire rope having a first end and a second end;  
3 a first elongated solid attachment connected to said first end of said wire rope;  
4 and  
5 a second elongated solid attachment connected to said second end of said wire  
6 rope, wherein  
7 at least a portion of said wire rope is coated with a substance to prevent  
8 the wire rope from bonding with said concrete.
- 1 2. The wire bolt of claim 1 wherein said elongated section of wire rope is pre-  
2 stretched.
- 1 3. The wire bolt of claim 1 wherein at least a portion of said first elongated solid  
2 attachment is threaded.
- 1 4. The wire bolt of claim 3, further comprising a nut attached to said threaded  
2 portion of said first elongated solid attachment.
- 1 5. The wire bolt of claim 1 wherein at least a portion of said second elongated  
2 solid attachment is threaded.
- 1 6. The wire bolt of claim 5, further comprising a nut attached to said threaded  
2 portion of said second elongated solid attachment.
- 1 7. The wire bolt of claim 1 wherein said solid attachment is connected to said  
2 wire rope by cold forming.
- 1 8. The wire bolt of claim 7 wherein said solid attachment is connected to said  
2 wire rope by swaging.
- 1 9. A method for strengthening concrete, such method comprising:  
2 furnishing a wire bolt, comprising:  
3 an elongated section of wire rope having a first end and a second end;  
4 a first elongated solid attachment connected to said first end of said  
5 wire rope; and  
6 a second elongated solid attachment connected to said second end of  
7 said wire rope;  
8 coating at least a portion of said wire bolt with a substance to prevent the wire  
9 rope from bonding with said concrete;

- 10           embedding said elongated solid attachments in said concrete using an  
11 appropriate adhesive; and  
12           allowing said adhesive to cure within said concrete.
- 1    10.    The method of claim 9, further comprising the steps of:  
2           pre-stretching said elongated section of wire rope.
- 1    11.    The method of claim 9 wherein at least a portion of said first elongated solid  
2 attachment is threaded.
- 1    12.    The method of claim 9 wherein at least a portion of said second elongated  
2 solid attachment is threaded.
- 1    13.    The method of claim 9, further comprising the steps of:  
2           drilling a socket in the concrete;  
3           injecting said adhesive into said socket;  
4           embedding only said first attachment in said adhesive, such that at least a  
5 portion of said second attachment remains exposed; and  
6           attaching a nut to the exposed threaded portion.
- 1    14.    The method of claim 13, further comprising the steps of:  
2           after said adhesive has cured, post tensioning said wire bolt.

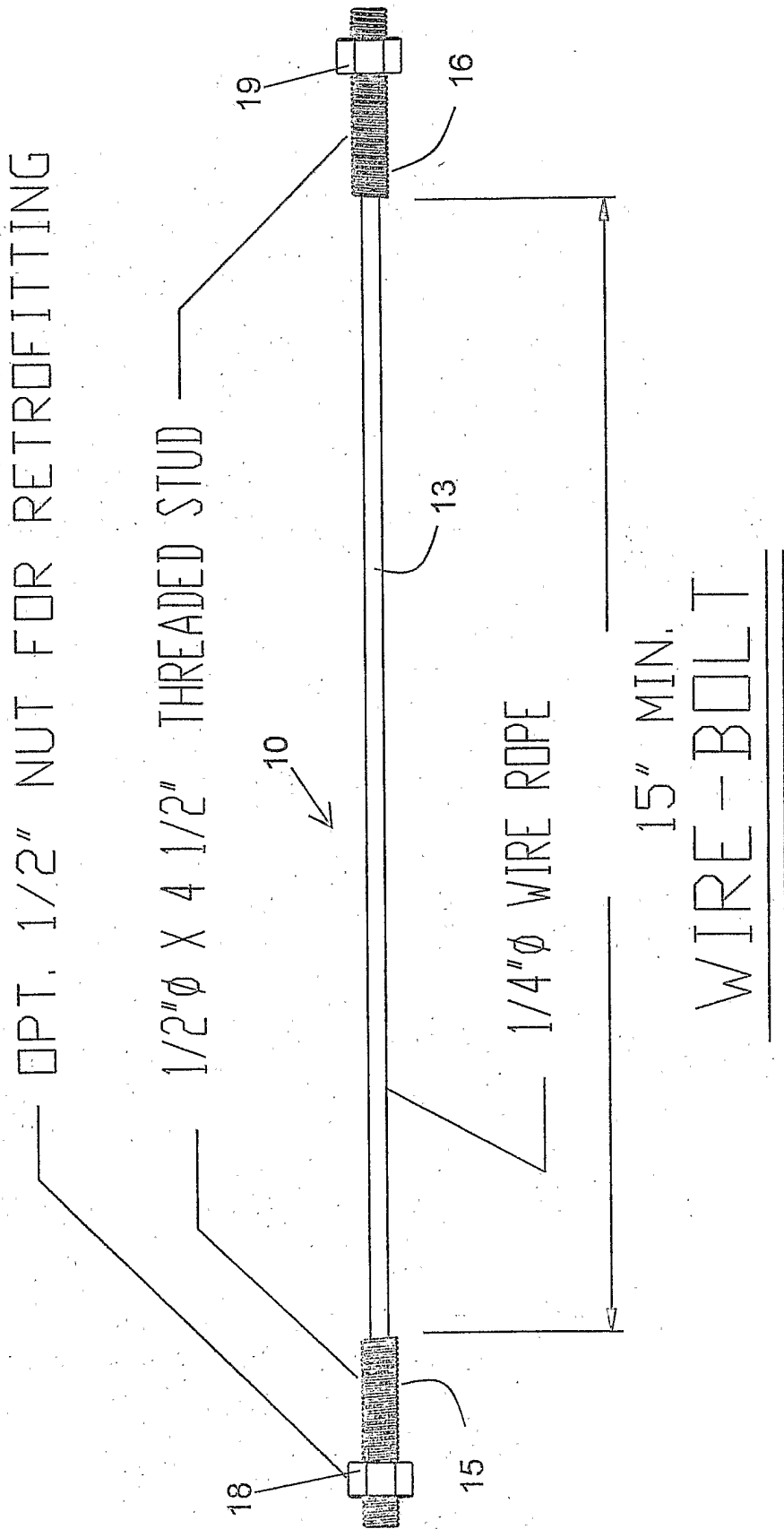

Figure 1

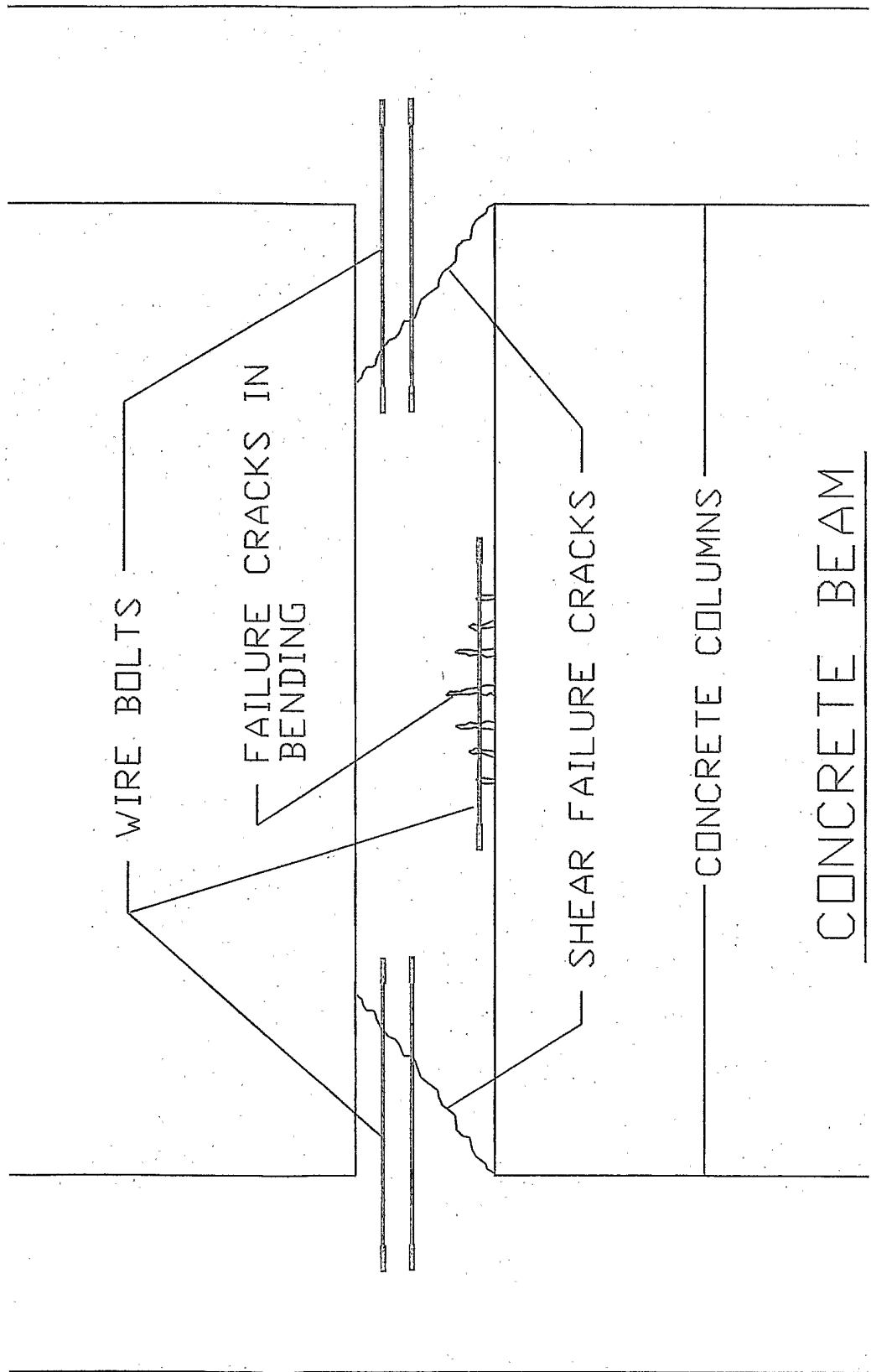

Figure 2

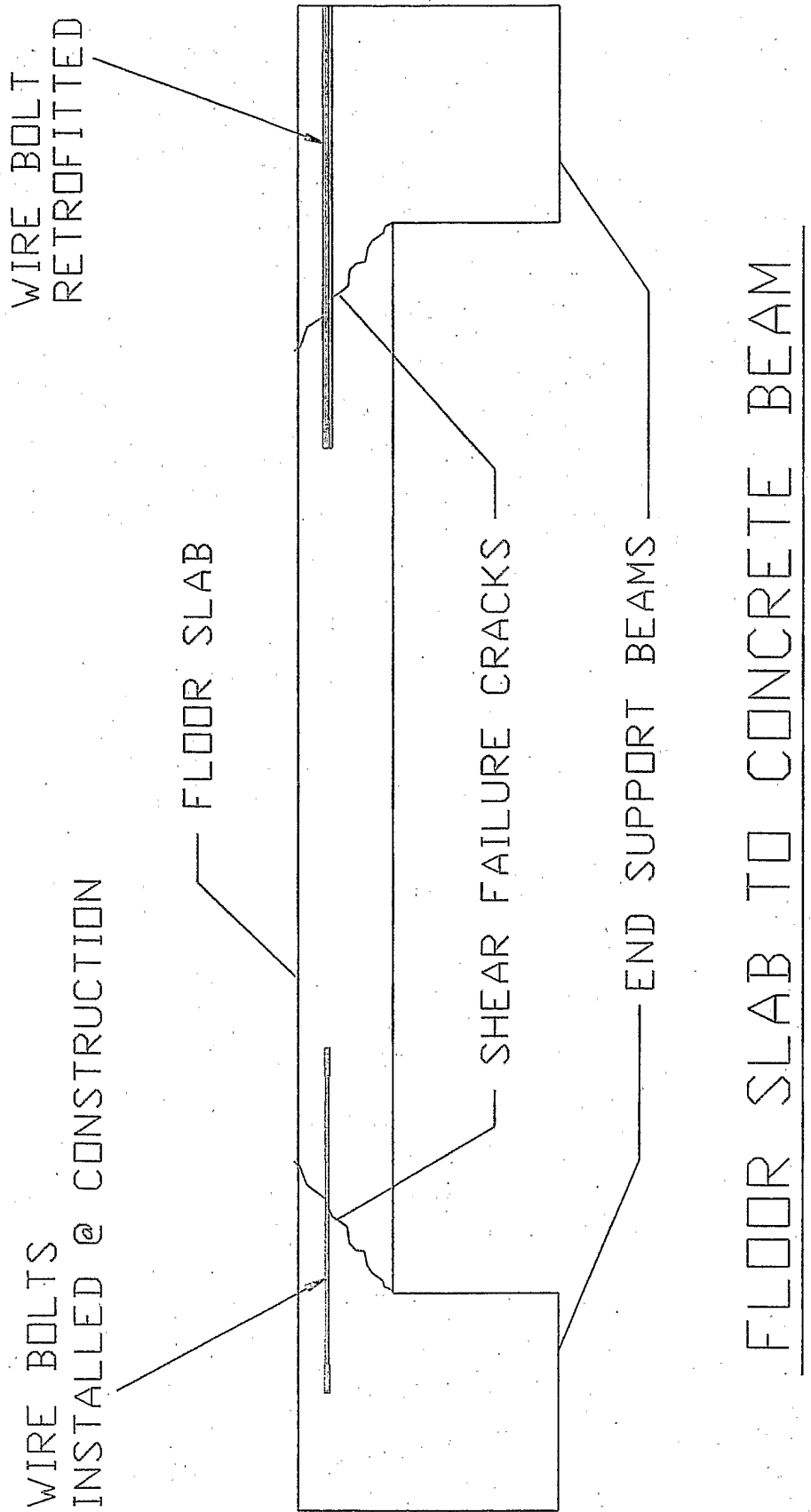
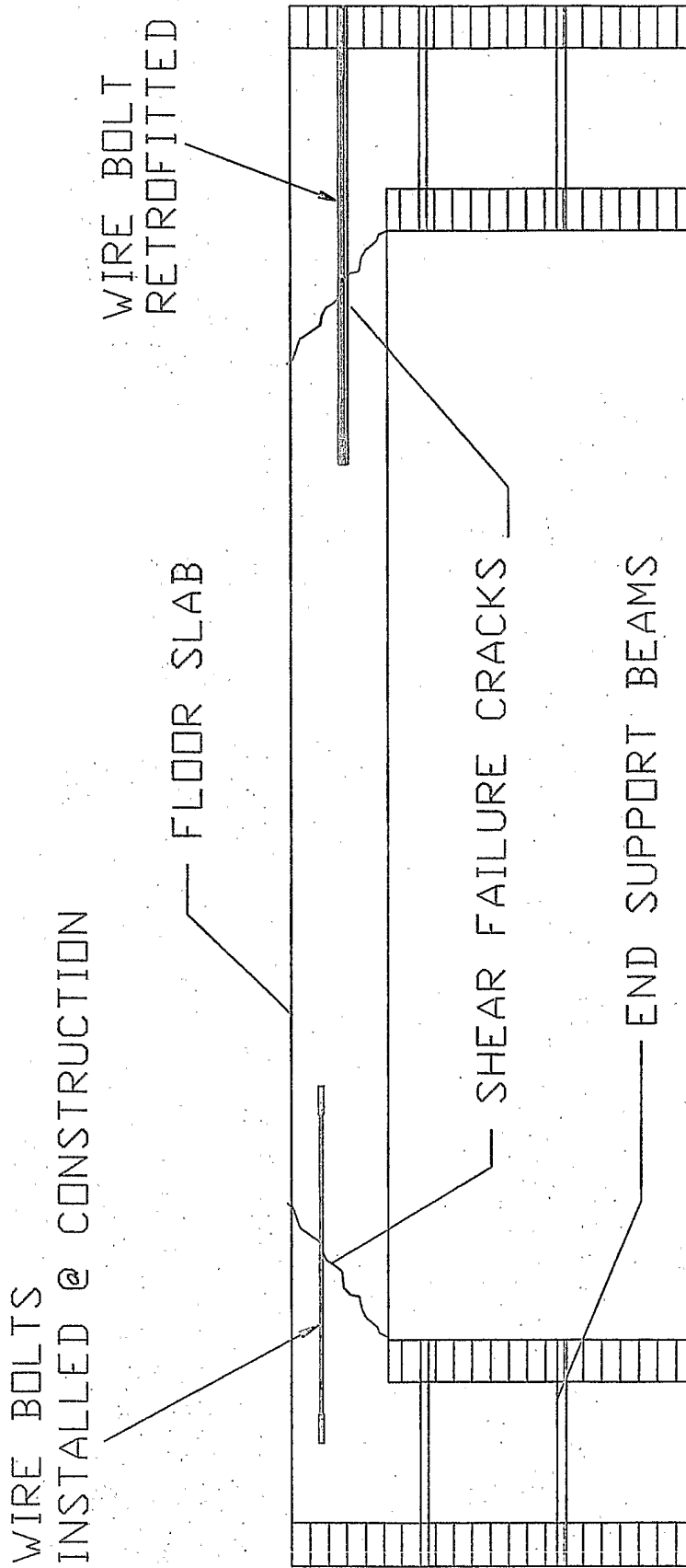

Figure 3



FLOOR SLAB TO CMU TIE BEAM

Figure 4

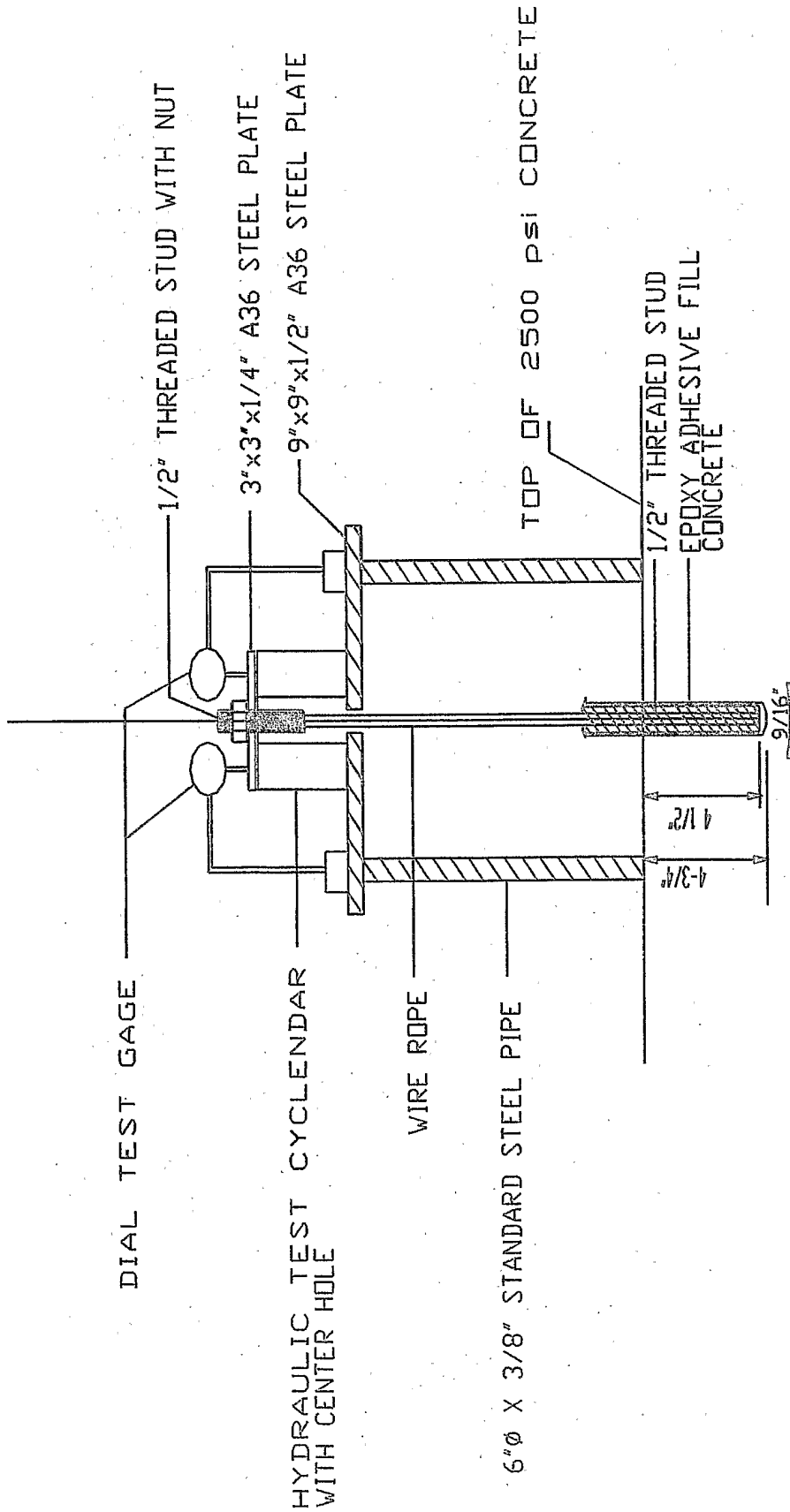

Figure 5