

No. 762,917.

PATENTED JUNE 21, 1904.

O. L. LARSON.
PNEUMATIC STACKER.
APPLICATION FILED JUNE 12, 1903.

2 SHEETS—SHEET 1.

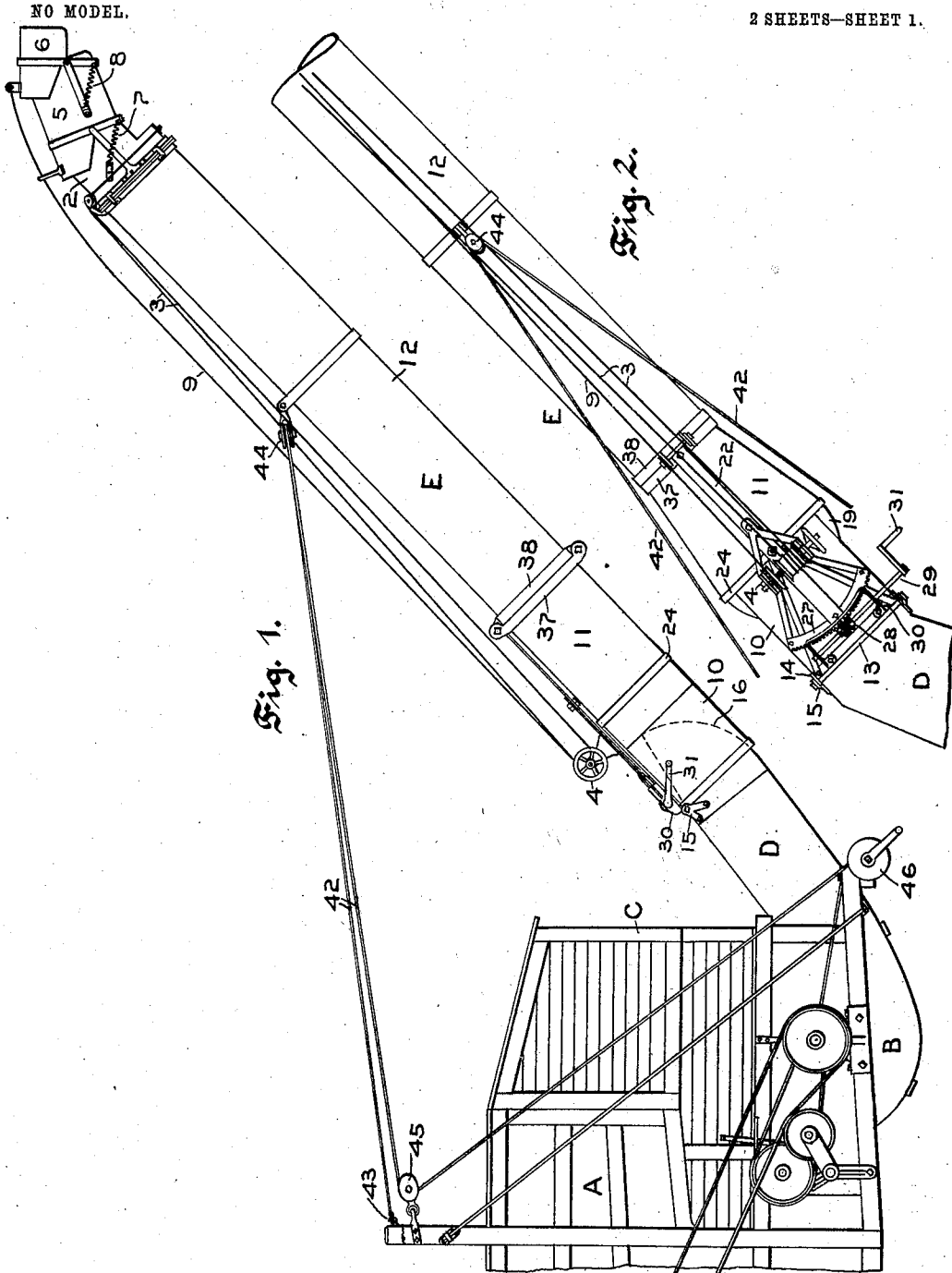

Witnesses,
W. H. Palmer
Emily F. Otis

Inventor,
Ole J. Larson.
by Lothrop & Johnson
his Attorneys.

O. L. LARSON.
PNEUMATIC STACKER.
APPLICATION FILED JUNE 12, 1903.

NO MODEL.

2 SHEETS—SHEET 2.

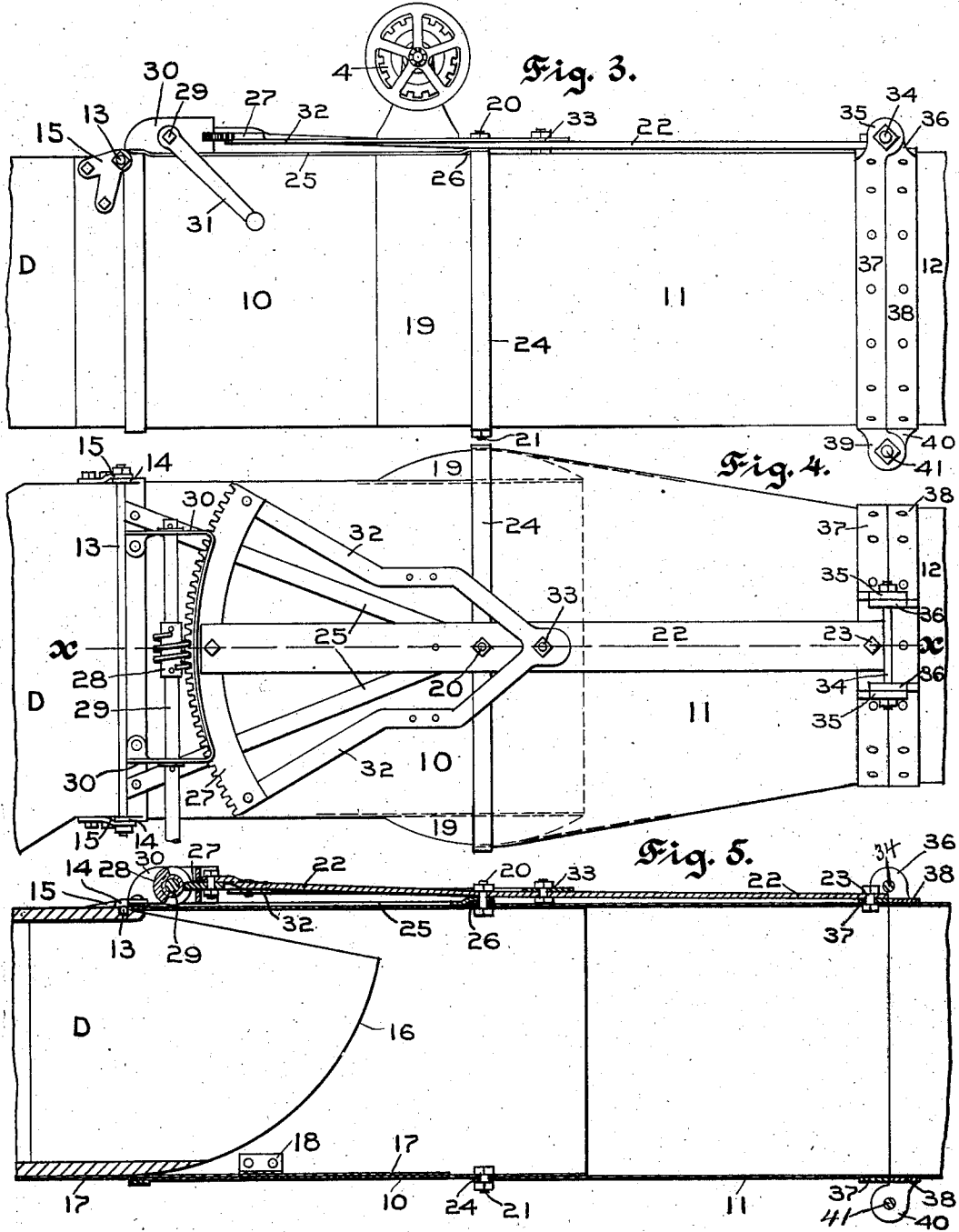

Witnesses,
W. H. Palmer.
Emily F. Otis

Inventor,
Ole L. Larson.
by Lotthrop & Johnson
his Attorneys

UNITED STATES PATENT OFFICE.

OLE L. LARSON, OF MINNEAPOLIS, MINNESOTA, ASSIGNOR TO FOSSTON WIND STACKER COMPANY, OF MINNEAPOLIS, MINNESOTA, A CORPORATION OF MINNESOTA.

PNEUMATIC STACKER.

SPECIFICATION forming part of Letters Patent No. 762,917, dated June 21, 1904.

Application filed June 12, 1903. Serial No. 161,150. (No model.)

To all whom it may concern:

Be it known that I, OLE L. LARSON, a citizen of the United States, residing at Minneapolis, in the county of Hennepin and State of Minnesota, have invented certain new and useful Improvements in Pneumatic Stackers, of which the following is a specification.

My invention relates to improvements in pneumatic stackers, and particularly in the discharge trunks or chutes thereof and the means for swinging them, its object being to improve and simplify the construction of joint and the mechanism for swinging the trunk.

To this end my invention consists in the features of construction, combination, and arrangement of parts hereinafter described and claimed.

In the accompanying drawings, forming part of this specification, Figure 1 is a side elevation of a stacker embodying my invention, showing the stacker in place upon the rear end of a threshing-machine. Fig. 2 is a top view of the discharge-trunk with the outer portion broken away. Fig. 3 is a side elevation, upon an enlarged scale, of the inner-sections of the trunk adjacent to the discharge-throat of the fan-casing. Fig. 4 is a top view of the same, and Fig. 5 is a longitudinal vertical section taken on line *xx* of Fig. 4.

In the accompanying drawings, A represents the rear end of a threshing-machine; B, the fan-casing of the stacker; C, the frame or housing therefor; D, the throat of the fan-casing, and E the discharge trunk or chute leading from the throat of the fan-casing and carrying at its outer end a hood F. The hood may be of any desired construction. As shown in the drawings it is made up of a rotatable section 2, which may be revolved by a cable 3, passing over a windlass 4 upon the trunk, and two overlapping pivoted sections 5 and 6, which are held normally in downwardly-deflected position by springs 7 and 8, respectively, and may be raised against the tension of the springs by a cable 9, passing over the windlass 4.

The discharge-trunk comprises a hinged inner section 10, which is capable of angular

movement in a vertical plane only, a swing-section 11, capable of angular movement relatively to the inner section in a transverse plane only, and a hinged outer section 12, capable of angular movement relatively to the swing-section in a vertical plane only. The inner section 10 is hinged at the top to the top of the throat D by a hinge-rod 13, having bearings in the lugs 14 and 15 upon the trunk-section and throat, respectively. The throat of the fan-casing terminates in a portion extending within the trunk-section 10 and having side walls with upwardly-curved end edges 16 and a flexible sheet-metal bottom wall 17, secured to the bottom of the throat at its inner end only and being otherwise free and unsecured. This sheet-metal bottom 17 extends normally along the inside of the bottom wall of the trunk-section and is slidable between that and the guide 18 upon the side wall of the trunk-section. Thus as the trunk-section is swung up or down upon its hinge-rod 13 the flexible metal-sheet 17 will always lie against the inner side of the bottom wall of the trunk-section, where it will not be in the way of the material discharged through the trunk.

In order to secure a tight joint between the adjacent telescoping ends of the inner trunk-section 10 and the swing-section 11 in whatsoever direction the swing-section may be turned, one of the trunk-sections, preferably the inner section 10, as shown in the drawings, is provided at each side with a curved segment 19, curved upon the arc of a circle of which the pivot 20 is at the center, and the other trunk-section, preferably the swing-section 11, is telescoped over the segments 19 and the trunk-section carrying them far enough to reach the middle of the segments or, more precisely, the radii of the segments which bisect the segments and are perpendicular to the longitudinal axis of the trunk-section carrying them. The two telescoped trunk-sections are pivoted together at top and bottom in a line perpendicular to their longitudinal axes by pivots 20 and 21, respectively.

As these pivots are at the center of the circle of which the curved members 19 are segments, it will be evident that when the swing-section and the outer trunk-sections secured thereto are swung laterally the ends of the telescoping portion of the swing-section will follow the curve of the arc of the segment and always be tangential thereto, and the swing-section cannot be swung so far as to expose the end of the inner section.

To swing the trunk upon the joint above described, a lever 22 is secured at one end by the rivet 23 or otherwise to the outer end of the swing-section. The lever is fulcrumed between its ends upon the pivot 20, which passes also through the strap 24 upon the end of the swing-section 11, as well as through the inner trunk-section 10 and the braces 25 secured thereon, the braces being turned up at the ends and carried over the strap 24 of the swing-section, both to support the pivot 20 and to form a shoulder 26 to assist in bearing the thrust of the outer portions of the trunk. To the inner end of the lever 22 is secured a toothed segment 27, which is engaged by a worm 28, mounted upon a shaft 29, journaled in brackets 30 upon the inner trunk-section and carrying at one end an operating-crank 31. The toothed segment 27 has radial arms 32 secured to the lever at a point 33 between the fulcrum-pivot 20 and the outer or acting end of the lever, so that the power is applied to the lever at two widely-separated points and the strain is correspondingly distributed.

The outer section 12 of the trunk is hinged at the top to the top of the outer end of the swing-section by a hinge-rod 34, having bearings in the lugs 35 and 36, secured to the bands 37 and 38 upon the swing-section and outer section, respectively. These bands are also provided at the bottom with overlapping lugs 39 and 40, through which a detachable locking-pin 41 is passed when the trunk is extended for use. When not in use, the trunk may be folded back upon the hinge-rods 13 and 33 over the top of the stacker-frame and threshing-machine.

To support the discharge-trunk and to raise it in a vertical plane, a cable 42 is secured to one side of the threshing-machine at any convenient place and by any convenient means, such as the hook 43, then passed over a pulley 44, secured to the trunk near its outer end, and thence carried back and passed over a pulley 45 upon the opposite side of the machine, and finally passed over a windlass 46, secured to the stacker-frame at a convenient place near the bottom thereof.

Having now described my invention, what I claim as new, and desire to secure by Letters Patent, is—

1. A discharge-trunk for pneumatic stackers comprising two telescoping sections connected by a transverse pivot so as to be capa-

ble of swinging laterally thereon, one of the sections having at each side an outwardly-curved segment, and the other section being telescoped over said segments, for the purpose described.

2. A discharge-trunk for pneumatic stackers comprising two telescoping trunk-sections pivoted together in a line perpendicular to their longitudinal axes so as to be capable of swinging laterally upon such pivot, one of the sections having at each side an outwardly-curved segment and the other section being telescoped over said segments, for the purpose described.

3. A discharge-trunk for pneumatic stackers, comprising two telescoping trunk-sections pivoted together at the top so as to be capable of angular lateral movement with respect to each other, one of the sections having at each side an outwardly-curved segment and the other section being telescoped over the segments to the radii thereof perpendicular to the longitudinal axes of the trunk-sections, and means for swinging one of the sections.

4. A discharge-trunk for pneumatic stackers, comprising two telescoping trunk-sections having pivotal connection in a line perpendicular to their longitudinal axes so as to be capable of swinging laterally upon such pivotal connection, one of said sections having at each side a curved segment having its center at said point of pivotal connection, and the other section being telescoped over the segments to the radii thereof perpendicular to the longitudinal axes of said trunk-sections, and means for swinging one of the sections.

5. In a pneumatic stacker, in combination, a fan-casing having an outwardly-extending throat, and a discharge-trunk leading from said throat and comprising an inner trunk-section suitably connected with the throat and a swing-section, the inner section having at each side an outwardly-curved segment and the swing-section being telescoped over said segments to the bisecting radii thereof perpendicular to the longitudinal axis of the inner section, said sections having pivotal connection at approximately the common center of said segments, and means for swinging the swing-section.

6. In a pneumatic stacker, in combination, a fan-casing having a discharge-throat, a discharge-trunk having an inner section connected with the throat and a swing-section having swinging connection with the inner section, a lever fulcrumed upon the inner section and secured at its acting end to the swing-section, a toothed segment secured to the lever, and a worm carried by the inner section in position to intermesh with the toothed segment to turn the lever and the swing-section secured thereto.

7. In a pneumatic stacker the combination, with the fan-casing and its discharge-throat, of a discharge-trunk having an inner section

5 suitably connected with said throat and a
swing-section pivotally connected with the
inner section, a lever secured at one end to
the swing-section and carrying at the other
end a toothed segment, said lever being ful-
crumed upon the inner section, and a worm
supported by the inner section and intermesh-
ing with the toothed segment to turn the lever,
the toothed segment having arms secured
to the lever at a point between its fulcrum
and its acting end, for the purpose described.

10 8. In a pneumatic stacker, in combination,
a fan-casing, a discharge-trunk having an in-
ner section leading from the fan-casing and a
swing-section having swinging connection
with the inner section, a lever fulcrumed upon
the inner section and connected at one end
with the swing-section, intermeshing gears
upon the other end of the lever and upon the

inner section whereby the lever is turned to
swing the swing-section. 20

9. In a pneumatic stacker, in combination,
a fan-casing, a discharge-trunk having an in-
ner section leading from the fan-casing and a
swing-section having swinging connection 25
with the inner section, a lever connected at
one end with the swing-section and carrying
at the other end a toothed segment, the lever
being fulcrumed intermediately upon the in-
ner section, and a worm carried by the inner 30
section in position to mesh with the toothed
segment to turn the lever.

In testimony whereof I affix my signature in
presence of two witnesses.

OLE L. LARSON.

Witnesses:

ARTHUR P. LOTHROP,
EMILY F. OTIS.