

(19) World Intellectual Property
Organization
International Bureau



(43) International Publication Date
3 November 2005 (03.11.2005)

PCT

(10) International Publication Number
WO 2005/102901 A2

- (51) International Patent Classification⁷: **B66B 23/12**
- (21) International Application Number:
PCT/FI2005/000167
- (22) International Filing Date: 29 March 2005 (29.03.2005)
- (25) Filing Language: Finnish
- (26) Publication Language: English
- (30) Priority Data:
20040565 22 April 2004 (22.04.2004) FI
- (71) Applicant (for all designated States except US): **KONE CORPORATION** [FI/FI]; Kartanontie 1, FI-00330 Helsinki (FI).
- (72) Inventors; and
- (75) Inventors/Applicants (for US only): **AULANKO, Esko** [FI/FI]; Käenkatu 6 C 33, FI-04230 Kerava (FI). **MUSTA-LAHTI, Jorma** [FI/FI]; Raivaajantie 13, FI-05620 Hyvinkää (FI). **OSSENDORF, Marc** [DE/DE]; Elsterstr. 22, D-44892 Bochum (DE).
- (74) Agent: **KONE CORPORATION / Patent Department**; P.O. Box 677, FI-05801 Hyvinkää (FI).
- (81) Designated States (unless otherwise indicated, for every kind of national protection available): AE, AG, AL, AM, AT, AU, AZ, BA, BB, BG, BR, BW, BY, BZ, CA, CH, CN, CO, CR, CU, CZ, DE, DK, DM, DZ, EC, EE, EG, ES, FI, GB, GD, GE, GH, GM, HR, HU, ID, IL, IN, IS, JP, KE, KG, KP, KR, KZ, LC, LK, LR, LS, LT, LU, LV, MA, MD, MG, MK, MN, MW, MX, MZ, NA, NI, NO, NZ, OM, PG, PH, PL, PT, RO, RU, SC, SD, SE, SG, SK, SL, SM, SY, TJ, TM, TN, TR, TT, TZ, UA, UG, US, UZ, VC, VN, YU, ZA, ZM, ZW.
- (84) Designated States (unless otherwise indicated, for every kind of regional protection available): ARIPO (BW, GH, GM, KE, LS, MW, MZ, NA, SD, SL, SZ, TZ, UG, ZM, ZW), Eurasian (AM, AZ, BY, KG, KZ, MD, RU, TJ, TM), European (AT, BE, BG, CH, CY, CZ, DE, DK, EE, ES, FI, FR, GB, GR, HU, IE, IS, IT, LT, LU, MC, NL, PL, PT, RO, SE, SI, SK, TR), OAPI (BF, BJ, CF, CG, CI, CM, GA, GN, GQ, GW, ML, MR, NE, SN, TD, TG).
- Published:**
— without international search report and to be republished upon receipt of that report
- For two-letter codes and other abbreviations, refer to the "Guidance Notes on Codes and Abbreviations" appearing at the beginning of each regular issue of the PCT Gazette.

(54) Title: PALLET ARRANGEMENT FOR A TRAVELATOR OR EQUIVALENT

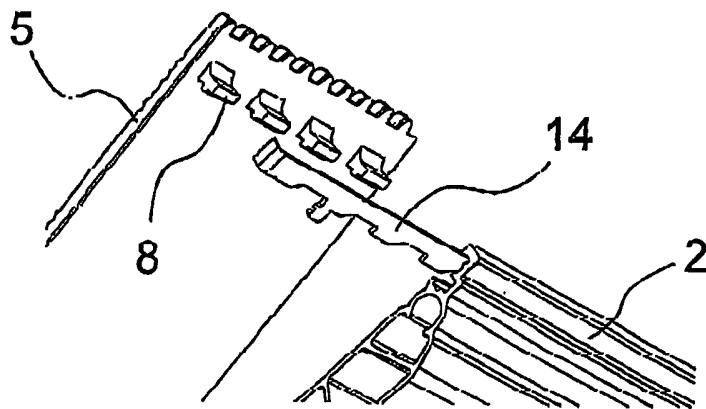

(57) Abstract: The invention relates to a pallet arrangement for a travelator or equivalent, in which arrangement a pallet (1) moving on wheels (3) forms part of the track and which pallet consists of at least a pallet body (2) and at least one surfacing element (5) attached to the body (2). The surfacing element (5) is fastened to the body (2) of the pallet (1) by means of one or more coupling elements (8) provided at least in the surfacing element (5) and a shape-locking groove (10) provided in the body (2) as well as a locking element (13, 14) so that in the locking operation the locking movement and in the releasing operation the releasing movement has been arranged to act

on all the coupling elements (8) in the shape-locking groove (10) substantially simultaneously.

WO 2005/102901 A2

PALLET ARRANGEMENT FOR A TRAVELATOR OR EQUIVALENT

The present invention relates to a pallet arrangement for a travelator or equivalent as defined in the preamble of claim 5 1.

Travelators, like escalators, are conveying devices used to move people or goods. They differ from escalators e.g. in that they often work in a substantially horizontal position or in a 10 position somewhat inclined relative to their direction of motion so that successive steps, or pallets, form a substantially even and linear track instead of step-like stairs as in escalators. Travelators are also referred to as moving side-walks and autowalks.

15

In prior-art travelators, moving ramps and escalators, the pallets are typically made in one piece from pressure-molded aluminum or some other suitable metal or metal alloy. A problem with these structures is that the pressure molding tools 20 applicable for this purpose are very expensive. Another problem is that separate expensive tools are needed for each step or pallet type and for each width.

In addition, in prior-art pallet constructions e.g. plastic 25 comb strips or equivalent are used as decorative or warning elements. A drawback with these solutions is that mounting the comb strips is a difficult and time-consuming operation because in prior-art constructions they are generally fastened by means of screws to the routed edges of the steps or pal- 30 lets.

The object of the present invention is to overcome the above-mentioned drawbacks and to achieve an easily variable pallet structure of economical cost for use in a travelator, 35 autoramp, escalator or equivalent, a pallet structure that will also allow safety-improving solutions and various visual functions, such as the presentation of information or adver-

tisements, and that also allows fast and economical maintenance of the pallets because the surfacing part is easily replaceable and additionally permits the replacement of worn parts only, making it unnecessary to replace the entire pallet
5 due to wear of the surfacing. The pallet arrangement of the invention is characterized by what is disclosed in the characterization part of claim 1. Other embodiments of the invention are characterized by what is disclosed in the other claims.

10 The advantages of the pallet arrangement of the invention include low manufacturing costs and an easily variable surface structure consisting of different surfacing parts. An further advantage is improved user safety, because the light effects indicating the end of the track can be easily imple-
15 mented so that they are better visible than in previously known solutions, and the gaps between steps or pallets can be sealed better than in prior-art solutions. Yet another advantage is that the surface of the pallets can be used better than before as a displaying surface for information or adver-
20 tisements. An advantage is also the fact that maintenance of the equipment becomes easier and cheaper because only the surfacing parts subject to wear need to be replaced. An additional advantage is that the surfacing parts are fastened to the body of the step or pallet by shape-locked snap-on cou-
25 plings or equivalent that can be easily released and locked, allowing the joints to be easily uncoupled using a suitable tool. A further advantage are small investments on tools, and therefore the pallets, which are cut in suitable lengths from extruded long profiles, can be easily and quickly replaced
30 with a structure of a different type or shape when necessary.

In the following, the invention will be described in detail with reference to an embodiment example and the attached drawings, wherein

35

Fig. 1 presents a pallet according to the invention in a partially sectioned oblique top view,

- Fig. 2 presents a pallet according to the invention as seen from the end of the pallet and with the surfacing element turned partly apart,
- Fig. 3 presents a detail of the pallet according to
5 Fig. 2 with the surfacing element turned partly apart,
- Fig. 4 presents a detail of the pallet according to Fig. 2 with the surfacing element partly in its locking groove,
- 10 Fig. 5 presents a detail of the pallet according to Fig. 2 with the surfacing element locked on the body of the pallet,
- Fig. 6 presents a detail of a preferred structure according to an embodiment of the invention in an
15 oblique view from the end of the pallet and with the surfacing element locked on the pallet body,
- Fig. 7 presents a detail of the structure according to Fig. 6 in an oblique view from the end of the pallet and with the locking of the surfacing
20 element released,
- Fig. 8 presents a partially sectioned detail of the structure according to Fig. 6 in an oblique view from below the pallet and with the locking of the surfacing element activated,
- 25 Fig. 9 presents a partially sectioned detail of the structure according to Fig. 6 in an oblique view from below the pallet and with the locking of the surfacing element released, and
- Fig. 10 partially sectioned detail of the structure according to Fig. 6 in an oblique view from below
30 the pallet and with the locking of the surfacing element released and with one surfacing element partly detached.

35 The pallet structure 1 of the invention comprises a pallet body 3, which is preferably made by extruding a suitable profile from aluminum or some other appropriate metal or

alloy. In the manufacture of the profile, a certain type of profile is extruded in bars of a length well suited for manufacture, transportation or other purposes. From these profiled bars, parts of a length exactly appropriate for the purpose are cut later during manufacture of the pallet. Thus, the same profile can be easily used for pallets of different lengths, so the width of the moving track of the travelator can be easily varied. Fastened to the pallet body 2 are wheels 3 at each end of the pallet and likewise at at least one end a fastening element 4 used to connect the pallet 1 to an endless chain, cogged belt, rope or an equivalent means of moving the pallets. In addition, one or more surfacing elements 5 extruded from plastic or corresponding material which form the wearing surface of the pallets, which also contains the required corrugations in the direction of the track of motion of the pallets, are fastened onto the body 2 of the pallet. Placed between the lower surface of the surfacing element 5 and the upper surface of the pallet body 2 is additionally a baffle 6, which is intended to smooth out any unevenness between the surfacing element 5 and the body and to baffle clacking, squeaking or similar disturbing sounds. The baffle 6 may be a thin metal sheet or preferably a sheet of a material softer than metal, such as plastic, rubber or equivalent.

25

The width of the surfacing elements 5 of the invention is so defined that, using a suitable number of surfacing elements 5 of the same width or different widths, it is possible to cover pallet bodies of different widths, so the same parts can be used to assemble pallets of different lengths.

As seen from the end of the pallet, each surfacing element 5 has at each edge, preferably in the lower part or on the lower surface of the surfacing element, one or more shape-locked coupling elements or similar coupling elements 7 and 8, which are disposed in suitable places at the ends of the surfacing element so that the surfacing elements are held

firmly in place on the pallet body 2, and that the surfacing elements can be easily pressed into position and likewise easily detached from the body with a suitable tool. Correspondingly, placed at suitable points substantially in the upper surface of the forward and rearward edges of the body 2 of the pallet are locking grooves 9 and 10 corresponding to the above-mentioned coupling elements, to which grooves the coupling elements 7 and 8 can be fastened by a shape-locked coupling.

10

As seen from the end of the pallet, the upper surface of the first edge of the pallet body 2 is provided with a locking groove 9 of a substantially L-shaped cross-section with its lower projection pointing towards the first edge of the pallet. The locking groove 9 has a length substantially covering the entire length of the pallet body 2. Correspondingly, the first edge of the surfacing element 5 is provided with one or more coupling elements 7 of L-shaped cross-section as seen from the end of the pallet, the lower projection of the coupling element extending towards the first edge of the surfacing element 5. The size and shape of the coupling element 7 are adapted to the size and shape of the locking groove 9 so that the surfacing element 5 can be locked by its first edge to the pallet body by inserting one or more coupling elements 7 into the locking groove 9 while the surfacing element 5 is in an inclined position and turning the surfacing element so that its lower surface becomes parallel to the upper surface of the pallet body.

30 As seen from the end of the pallet, the upper surface of the second edge of the pallet body 2 is provided with a shape-locking groove 10 located near the second edge and extending through the entire length of the pallet body 2. The inner edge of the groove 10 is provided with a recess 11 extending horizontally towards the middle part of the pallet body 2. Correspondingly, the inner surface of one or more coupling elements 8 near the second edge of the surfacing element 5 is

provided with a projection 8 corresponding to the recess 11. In addition, placed in the shape-locking groove 10 is a locking element 13 having a length substantially corresponding to the entire length of the pallet body 2, which element is e.g. an eccentric bar as shown in Fig. 2-5, one end of which bar extends outside the end of the body 2 and which end of the eccentric bar has a nut 19 or a corresponding shape to allow the eccentric shaft to be turned about its longitudinal axis with a tool. The size and shape of the coupling element 8 are adapted to the size and shape of the shape-locking groove 10 so that the surfacing element 5 can be locked by its second edge to the pallet body by pressing one or more of the coupling elements 8 into the shape-locking groove 10 and locking one or all of the coupling elements 8 in position in the shape-locking groove 10 by means of the locking element 13 in a single operation and by a single locking movement. In the solution illustrated in Fig. 2-5, the locking is effected by turning the eccentric shaft of the locking element 13 by means of a suitable tool from the end of the eccentric shaft, thereby locking all the coupling elements 8 simultaneously. Fig. 5 illustrates a situation where the coupling element 8 has been locked in the shape-locking groove 10 by means of the eccentric shaft of the locking element 13. In this situation, the projection 12 of the coupling element 8 is locked in the recess 11 of the shape-locking groove 10.

Figures 6-10 present a second preferred embodiment of the invention. In this embodiment, the surfacing element 5 and the coupling elements 7 and 8 have a structure substantially similar to that in the above-described first embodiment. Likewise, the locking groove 9 and the shape-locking groove 10 are substantially identical to those in the structure according to the embodiment described above. The structural and functional difference consists of a different locking element 14, which locks the surfacing element 5 in place with a single linear locking movement in the longitudinal direction of the body 2. Fig. 6 presents a situation where the

locking element 14 has been pushed into its locking position into the body 2, the surfacing element 5 being thus locked fast to the body 2. Correspondingly, Fig. 7 presents a situation where the locking element 14 has been pulled outwards from the end of the body 2 to a position where the surfacing element 5 is free to be lifted away from the locking groove 10.

In Fig. 8-10, the structure of the locking element 14 and its 10 locked and released positions are shown in more detail as seen from below the body. For the sake of clarity, part of the end of the body has been cut off in the figures. The shape of the shape-locking groove 10 has been fitted to be such that a flat and rectangular locking element 14 resembling a flat bar in cross-section can slide in the shape-locking groove 10 in the longitudinal direction of the pallet 15 body 2. The locking element 14 also has a length substantially equal to the length of the pallet body 2, and the end of the locking element 14 has a shape extending outside the 20 end of the body 2 to allow the locking element to be easily moved, such as an elbow 18 for moving the locking element. The inner edge 17 of the actual locking part is provided with cutouts 15 at regular distances, opening towards the midpart of the pallet body 2. The distance between the cutouts and 25 their shape and size correspond to the coupling elements 8 placed in a straight line at a horizontal distance from each other on the lower surface of the surfacing element. The rear edge of the cutout 15 is provided with a beveling 16 designed to allow the locking element 14 to be more easily pushed into 30 the locking position, wherein the inner edge 17 of the locking element presses the coupling elements 8 by their 8 outer surface against the inner edge of the shape-locking groove 10. This causes the projections 12 of the coupling elements to be pressed into the recess 11 in the locking groove and 35 the surfacing element 5 to be locked in place. To accomplish locking, the locking element 14 is pushed into position inside the body 2 or the locking element is struck on the elbow

18 at its end e.g. with a hammer to force the locking element in. In the locking operation all the coupling elements 8 are locked by the linear motion of the locking element 14 substantially simultaneously.

5

The surfacing element 5 is released by an operation converse with respect to the locking operation. The releasing is also accomplished by a single releasing movement that releases all the locking elements 8 simultaneously. When a locking element 10 13 Fig. 2-5 is used, the surfacing element is released by turning the eccentric shaft of the locking element 13 by the nut 19 at the end of the shaft e.g. with a fork wrench until coupling element 8 is loosened in the shape-locking groove 10 and lifting the coupling element 8 away from the shape- 15 locking groove 10 and pulling coupling element 7 obliquely away from the locking groove 9 at the first edge. Correspondingly, when a locking element 14 as illustrated in Fig. 6-10 is used, the locking of the coupling element 8 is released by pulling the locking element 14 outwards from the end of the 20 body through a suitable distance and lifting the coupling elements 8 away from the shape-locking groove 10.

The pallet of the invention may have surfacing elements 5 consisting of surface plates of different colors and also 25 transparent or translucent surface plates. Under these transparent or translucent surface plates, between the body and the surface plate it is possible to place e.g. a notice, advertisement or other element varying the appearance, printed on paper, plastic or similar material, which can be 30 illuminated from below or from the side to produce different visual effects. The transparent or translucent surface plates are preferably placed in the middle part of the pallet 1. By placing surface plates of different colors at different positions in the longitudinal direction of the pallet 1, it is 35 possible to vary the appearance of successive pallets, allowing the appearance of the moving track of the travelator to be easily changed and given a different look.

The solution of the invention also allows the gap between successive pallets 1 in the travelator to be made considerably wider than in prior-art solutions, even as much as about 5 ten times wider depending on the surfacing solutions, so that the transparent or translucent gap thus formed can be illuminated from below to warn e.g. about the danger posed by the approaching end of the moving track. Because the attention-arousing effect of the warning light in the wide gap thus 10 formed is very good, passengers concentrated on studying the notices or advertisements or equivalent can be effectively aroused to the danger caused by the approaching end of the moving track. When plastic elements are illuminated from the side, it is also possible to produce impressive illumination 15 effects as the light is scattered e.g. at the crests of the corrugations mentioned above.

When required, a suitable sealing surface or some other applicable sealing structure, such as a sealing lip, can also 20 be easily fastened to the extruded plastic surfacing element 5, said sealing being designed to close the gap between successive pallets 1. The use of sealings improves the operating safety, among other things, and prevents small objects from falling down into the mechanical structures of the travelator. 25 tor.

It is obvious to the person skilled in the art that the invention is not limited to the example described above, but that it may be varied within the scope of the claims presented below. Thus, the number, size and shape as well as the 30 functioning method of the locking grooves and locking elements may vary from that described above. Likewise, not all of the above-mentioned elements need necessarily to be used in the same pallet. A given pallet may be provided e.g. with 35 surface plates of only one type. Similarly, the material and method of manufacture of the pallet body may differ from the above description. Moreover, the size, shape, structure and

material of the surfacing elements may be different from those described above. Thus, for example, the surfacing part of the pallet may be made of a material other than plastic.

CLAIMS

1. A pallet arrangement for a travelator or equivalent, in which arrangement a pallet (1) moving on wheels (3) forms part
5 of the track and which pallet consists at least of a pallet body (2) and at least one surfacing element (5) attached to the body (2), **characterized** in that the surfacing element (5) is fastened to the body (2) of the pallet (1) by means of one or more coupling elements (8) provided at least in the surfac-
10 ing element (5) and a shape-locking groove (10) provided in the body (2) as well as a locking element (13, 14) so that in the locking operation the locking movement and in the releasing operation the releasing movement has been arranged to act on all the coupling elements (8) in the shape-locking groove
15 (10) substantially simultaneously.

2. A pallet arrangement according to claim 1, **characterized** in that the locking element (13, 14) is an elongated piece extending substantially in the longitudinal direction of the
20 pallet body (2) and having length substantially equal to the length of the body (2).

3. A pallet arrangement according to claim 1 or 2, **characterized** in that the locking element (13, 14) is located substan-
25 tially inside the body (2) so that one end of the locking element (13, 14) extends outside the end of the body (2).

4. A pallet arrangement according to claim 1, 2 or 3, **characterized** in that the end of the locking element (13, 14) extending outside the body (2) has a shape (18, 19) that allows
30 the locking element to be easily moved to implement the locking and releasing movements.

5. A pallet arrangement according to any one of the preceding
35 claims, **characterized** in that the locking element (13) consists of an eccentric bar turnable about its longitudinal axis

and having eccentric cams fitted to press the locking element (8) in the shape-locking groove (10) into their locked position.

5 6. A pallet arrangement according to any one of the preceding claims 1-4, **characterized** in that the locking element (14) consists of a flat bar linearly movable in the longitudinal direction of the body (2) and provided with cutouts (15), the inner edge (17) of said flat bar being adapted to press the
10 locking element ((8) in the shape-locking groove (10) into their locked position.

7. A pallet arrangement according to any one of the preceding claims, **characterized** in that the locking groove (9) in the
15 upper surface of the body and the shape-locking groove (10) have a length substantially equal to the length of the pallet body (2) and are substantially unchanged in cross-section over their entire length.

20 8. A pallet arrangement according to any one of the preceding claims, **characterized** in that the first edge of the pallet body (2) is provided with a locking groove (9) having substantially the shape of the letter L in cross-section, in which groove a coupling element (7) provided in the lower
25 surface of the surfacing element (5) and having a substantially L-shaped cross-section can be placed, and that the second edge of the body (2) is provided with a shape-locking groove (10) in which a coupling element (8) provided in the lower surface of the surfacing element (5) can be locked by
30 means of the locking element (13, 14).

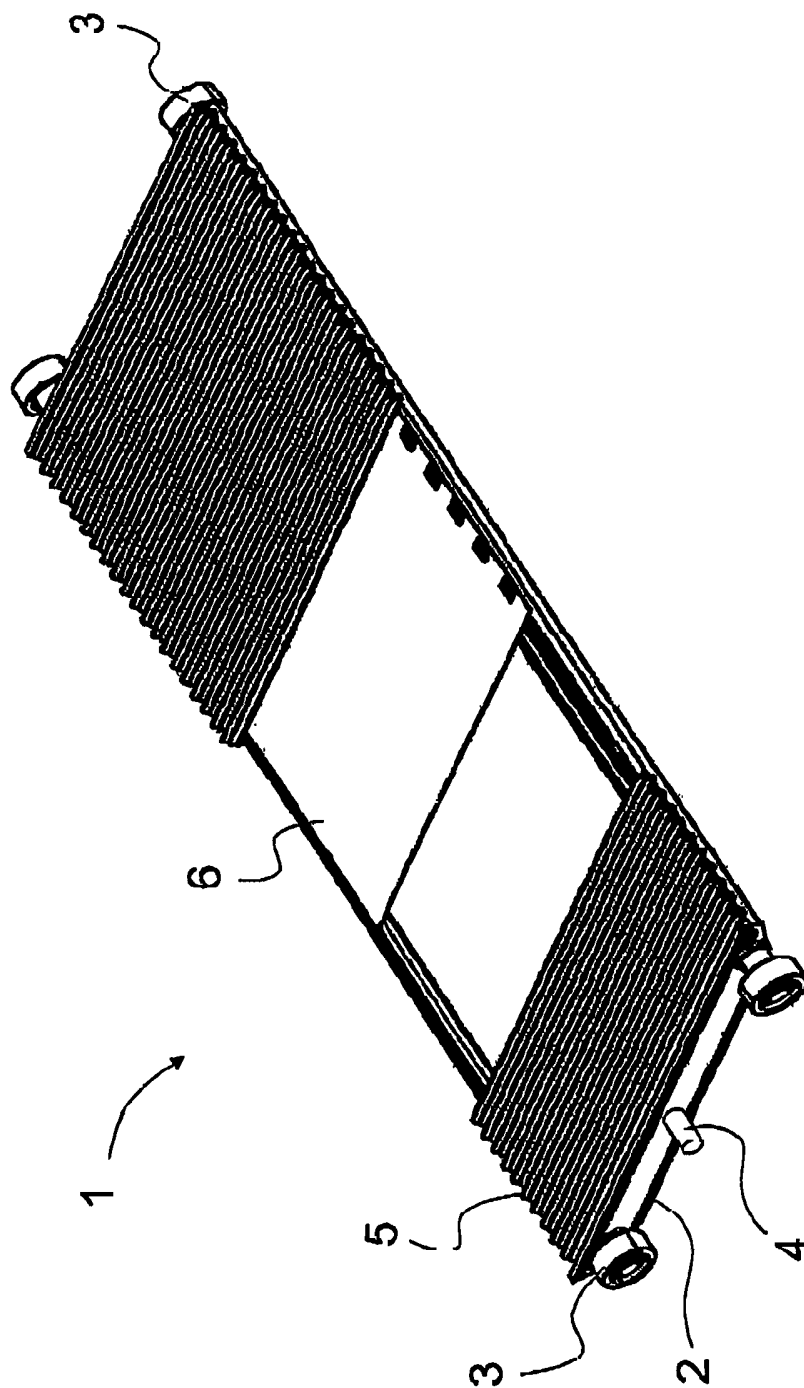

Fig. 1

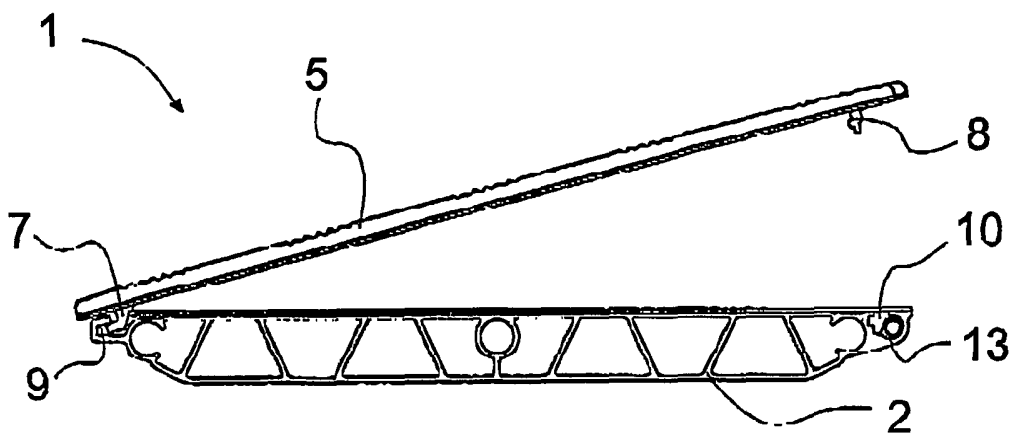

Fig. 2

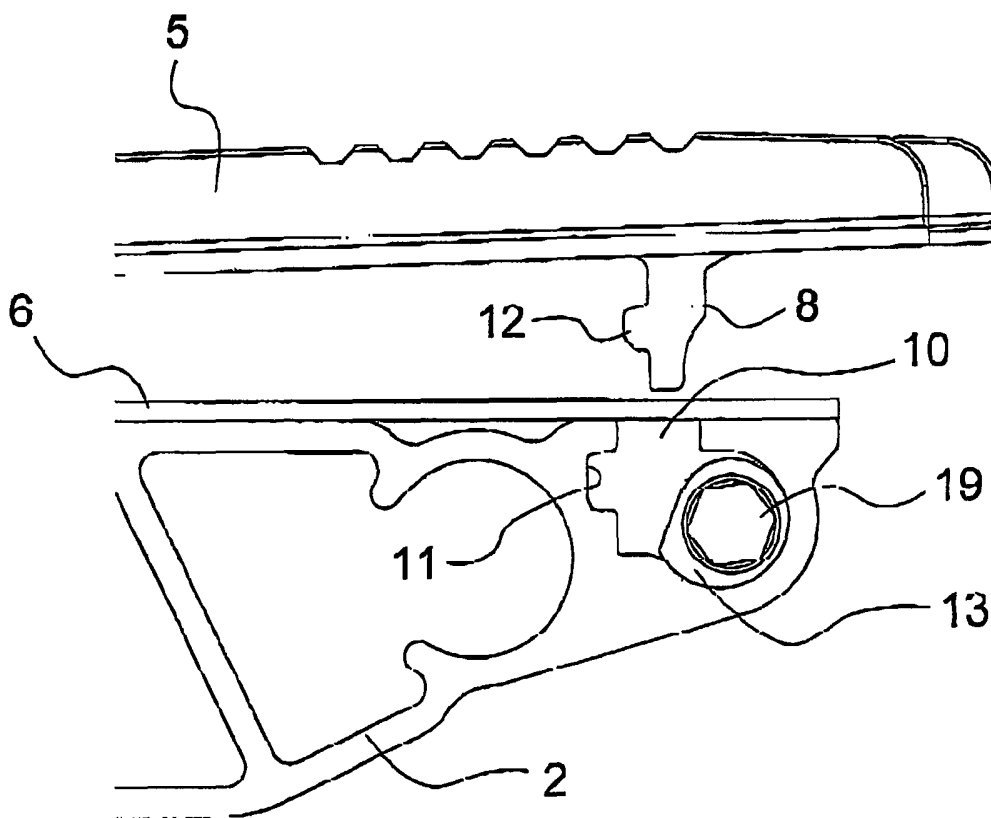

Fig. 3

3/5

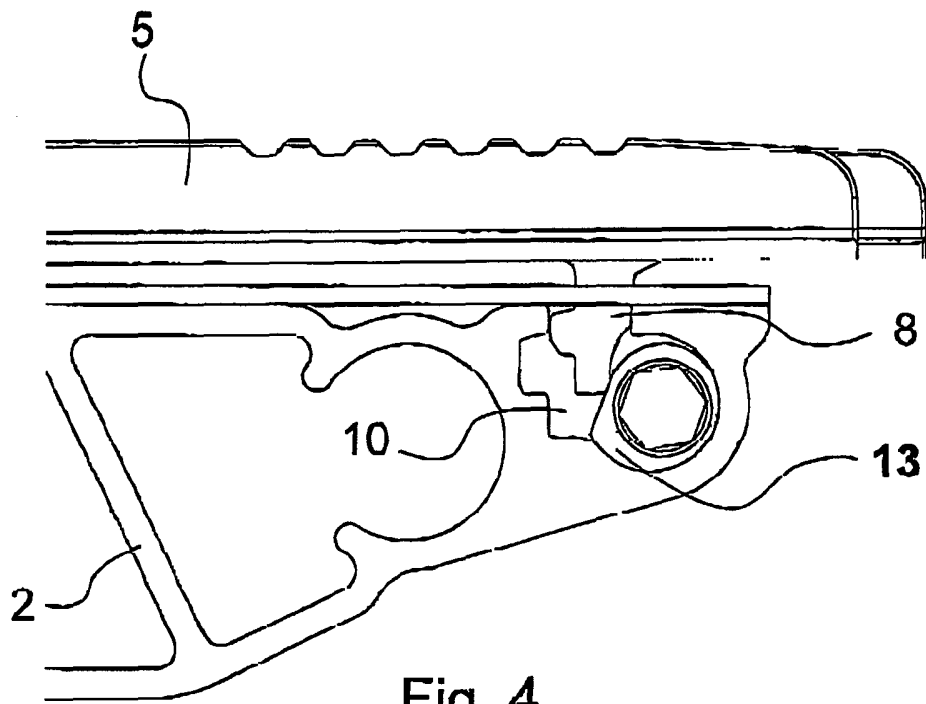

Fig. 4

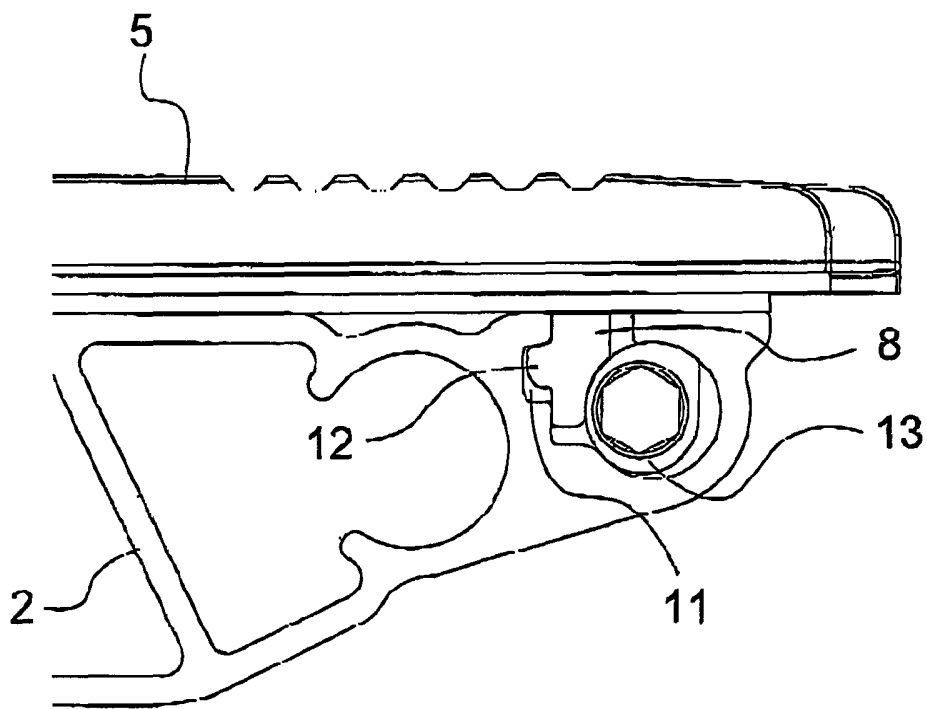

Fig. 5

4/5

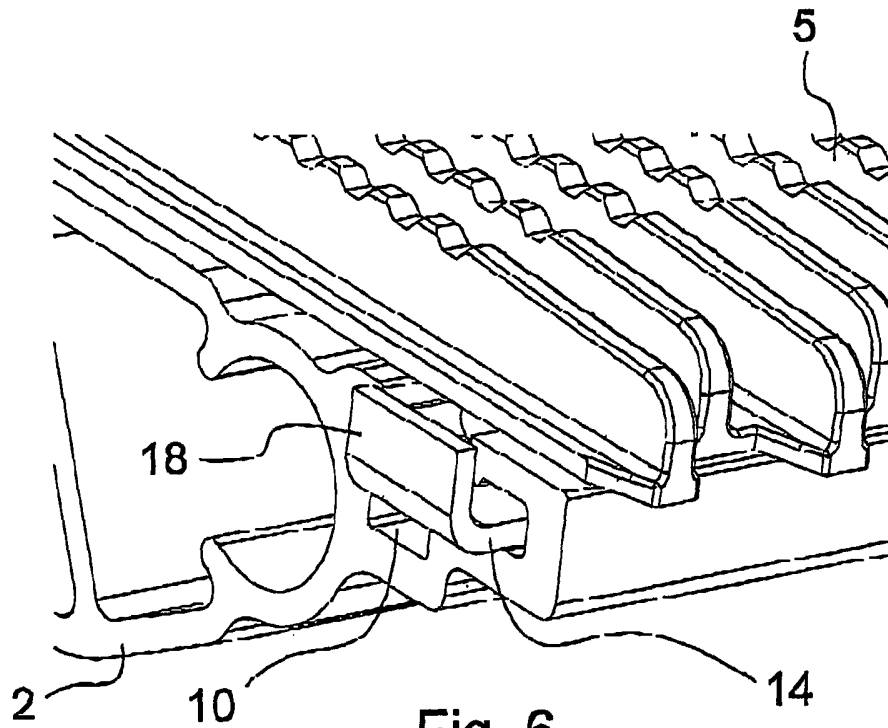

Fig. 6

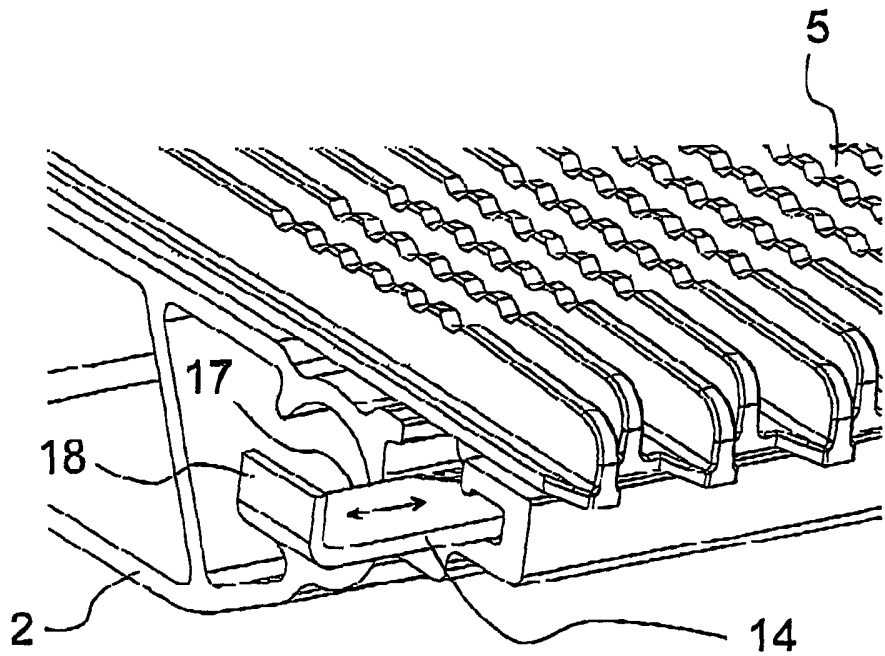

Fig. 7

5/5

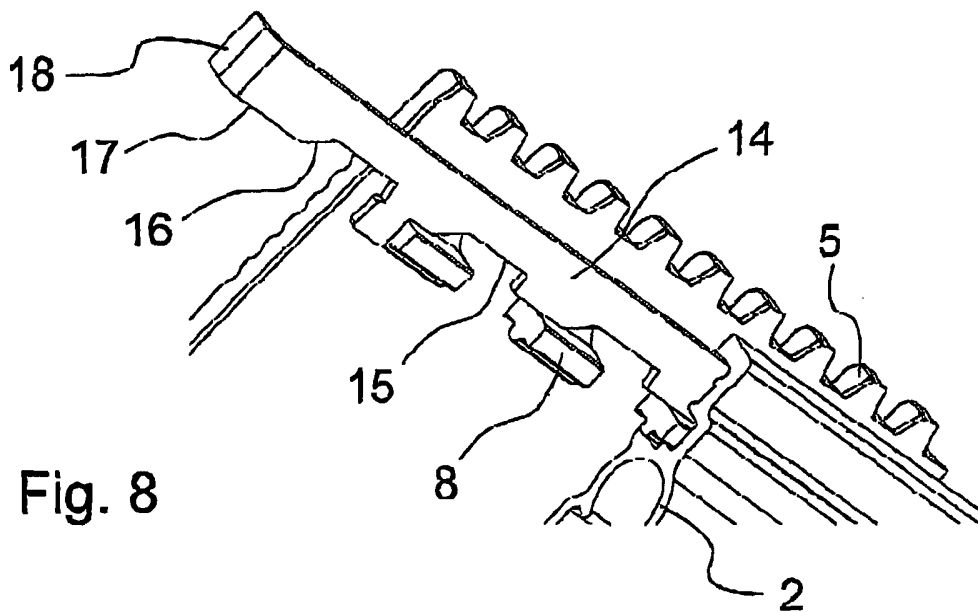

Fig. 8

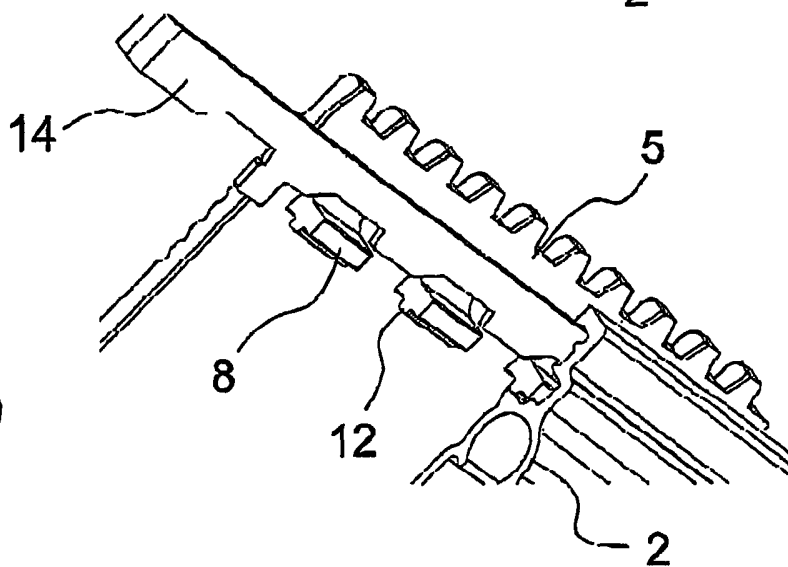

Fig. 9

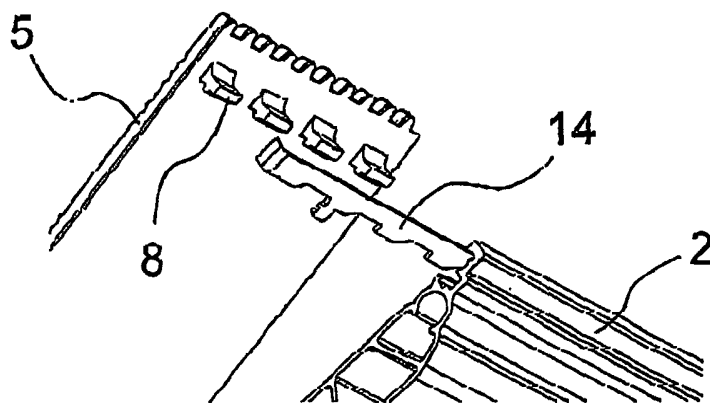

Fig. 10